

Sixteenth-century Hebrew typography:
A typographical and historical analysis
based on the Guillaume I Le Bé documents
in the Bibliothèque nationale de France

Volume One of Two
Chapters 1 to 5

Submitted in fulfilment of the requirements
for the Degree of Doctor of Philosophy

at the
University of London
School of Advanced Study
Institute of English Studies

Stephen Lubell
MA History of the Book (2008)
University of London
School of Advanced Study
Institute of English Studies

Supervisors:
Dr. Michelle P. Brown FSA
Professor Emerita, SAS, University of London
Visiting Professor, University College London
Visiting Professor, Baylor University
Distinguished Scholar, Green Scholars Initiative

Dr. J.F. Coakley
Manuscript Specialist, Cambridge University Library
Affiliated Lecturer on Syriac, Cambridge University Faculties
of Divinity and Asian & Middle Eastern Studies
Affiliated Researcher, Cambridge University Faculty
of Asian & Middle Eastern Studies

Date of Submission: 4 December 2013

Date of Viva: 21 March 2014

Abstract

This thesis is an analysis and examination of the Hebrew types that are to be found in the two documents or scrapbooks in the collections of the Bibliothèque nationale de France (N.A.F. 4528 and Rés X 1665), which were compiled by the sixteenth-century French punchcutter Guillaume I Le Bé (c. 1524 to 1598). Of the 53 specimens in the two documents, 20 were cut by Le Bé, and the rest by other known and unknown punchcutters of the sixteenth century. The 16 additional Greek, Music, Roman and Italic types in the documents are also shown, but are not analysed as part of the thesis. This thesis aims to present a detailed analysis of each distinct Hebrew typeface based on the methods developed principally by Hendrik Vervliet, combined with a book history approach which seeks to situate Le Bé in the context of his times using as much of the historical background as could be discovered from documentary evidence from the period. In addition, hypotheses are put forward as to methods of punch cutting, striking of matrices, casting and the composition of Hebrew types during this period. Over 200 separate Hebrew editions from the sixteenth and seventeenth centuries were examined to discover where and when these types were used, in order to draw conclusions concerning the spread of these types both during the sixteenth century and in later periods. This thesis contains a complete facsimile of the two documents together with a transcription and translation of the annotations by Guillaume I Le Bé, in addition to a comparative chart of the types included in the two documents, and other relevant documentary material. It also has a complete bibliographical apparatus of primary and secondary sources.

Dedicated to the memory of my extraordinary and inspiring parents:
Cecil Lubell 6 June 1912 – 19 July 2000
Winifred Milius Lubell 14 June 1914 – 3 January 2012

Table of Contents

Abstract	2
Table of Contents	4
List of Figures and Tables	7
Author's declaration	15
Chapter 1: Introduction	16
The research questions addressed in this thesis.....	21
Sixteenth-century printing and the place of Hebrew publishing within it	23
Primary and secondary source materials	28
The punchcutter as part of the printing process	31
The analysis of the typefaces in the two documents	37
The criteria used for description of the types.....	42
The criteria for the selection of Hebrew editions to be examined	46
The Hebrew alphabet and the varieties of Hebrew printing types	48
Chapter 2: Le Bé's types during his apprenticeship with Robert Estienne and in Venice	60
Le Bé's early years and his apprenticeship with Robert Estienne	60
The Estienne Hebrews and Le Bé's involvement in them.....	65
Hb1 (S).....	84
Hb2 (R).....	96
Hb3 (S).....	101
Hb4 (S).....	103
Hb5 (R).....	114
Hb6 (S).....	119
Hb7 (R).....	123
Hb8 (R).....	129
Hb9 (S).....	132
Hb10 (S).....	136
Chapter 3: Le Bé's types from his Paris period.....	144
Hb11 (S).....	168
Hb12 (S).....	184
Hb13 (S).....	192
Hb14 (S).....	206
Hb15 (S).....	213
Hb16 (R).....	217
Hb17 (S).....	220
Hb18 (R).....	223
Hb19 (S).....	229
Hb20 (R).....	232
Hb21 (S).....	235
Hb22 (R).....	237
Chapter 4: Analysis of Res X 1665 – Types by other punchcutters.....	241
Hb23 (S).....	242
Hb24 (S).....	245
Hb25 (S).....	254
Hb26 (S).....	256
Hb27 (S).....	258
Hb28 (S).....	262
Hb29 (S).....	267
Hb30 (S).....	274
Hb31 (R).....	277

Hb32 (S).....	280
Hb33 (S).....	285
Hb34 (R).....	289
Hb35 (S).....	293
Hb36 (R).....	301
Hb37 (S).....	303
Hb38 (S).....	310
Hb39 (S).....	315
Hb40 (S).....	319
Hb41 (S).....	322
Hb42 (S).....	325
Hb43 (R).....	326
Hb44 (R).....	328
Hb45 (S).....	332
Hb46 (S).....	336
Hb47 (R).....	339
Hb48 (S).....	341
Hb49 (R).....	342
Hb50 (A).....	343
Hb51 (A).....	354
Hb52 (A).....	360
Hb53 (A).....	362
Chapter 5: Synthesis and Discussion	363
Inventories relating to the Le Bé Typefoundry	368
Analysis of the editions examined for this thesis	381
Dispersals of the Le Bé Hebrew Types: Wechel, Zifroni, Prostitz and others.....	387
The Influence of the Le Bé types.....	391
Originality and progression in the Le Bé Hebrews.....	399
Closing discussion.....	404

APPENDICES	406
Appendix A: Comparative chart of the Le Bé Hebrew typefaces sorted according to size.....	407
Appendix B: Comparative table of text and titling Body sizes	410
Appendix C: Facsimiles, Transcriptions and Translations of the Le Bé document NAF 4528.....	414
Appendix D: Facsimiles, Transcriptions and Translations of the Le Bé document Rés X 1665.....	471
Appendix E: List of archival documents relevant to Guillaume I Le Bé	525
Appendix F: Transcription of the <i>Inventaire après décès</i> of Guillaume I Le Bé of 1598.....	545
Appendix G: The evidence of type distribution from the examined editions.....	578
Appendix H: The basic library documentation form	585
Appendix I: The Estienne Hebrew Editions – 1539 to 1545.....	587
Appendix J: Analysis of vowel points and cantillation mark combinations and their frequency.....	592
Appendix K: Typefounder's tools	617
Appendix L: Names of the books of the Masoretic Bible.....	622
ENDMATTER	625
Acknowledgements.....	626
Abbreviations.....	628
Glossary of terms	629
Permissions for use of Images	634
Index to technical matters discussed in this thesis	636
Primary sources.....	637
Secondary sources.....	654
Impressum.....	671

List of Figures and Tables

Fig. 1.1: Wood engraving of a type caster (Der Schriftgeisser) From Hans Sachs and Jost Amman, <i>Eygentliche Beschreibung aller Stände auff Erden</i> , Frankfurt am Main, 1568.	33
Fig. 1.2: Inscribing the character on the head of the punch – A clip from Stan Nelson video Punchcutting at the Atelier Press & Letterfoundry.....	35
Fig. 1.3: Leveling the head of the punch – A clip from Stan Nelson video Punchcutting at the Atelier Press & Letterfoundry	35
Fig. 1.4: A Punchcutter's tools of the seventeenth century. Plate III from Fournier's <i>Manuel Typographique</i>	36
Fig. 1.5: A Punchcutter's tools of the seventeenth century. Plate IV from Fournier's <i>Manuel Typographique</i>	36
Fig. 1.6: Example of risen type from Cologne edition 1476	40
Fig. 1.7: Example of a risen type from <i>Perush HaTorah</i> , ca. 1480 Mantova (From Freimann, <i>Thesaurus typographiae Hebraicae saeculi XV, A10,2</i>)	40
Fig. 1.8: The parts of a Hebrew typical type character	40
Fig. 1.9: Table of Hebraica holdings in the British Library and UCL Special Collections.....	47
Fig. 1.10: The Hebrew Alphabet, vowel points and cantillation marks.....	54
Fig. 1.11: The Hebrew Alphabet, vowel points and cantillation marks for Unicode setting. (By permission of John Hudson of Tiro Typeworks, Gulf Islands, British Columbia, Canada).....	55
Fig. 1.12: The basic varieties of Hebrew types (Raphael Frank, <i>Über Hebräische Typen und Schriftarten</i> , 1925).....	57
Fig. 2.1: The Le Bé family tree based on Le Clerc and the Fichier Chandon.....	63
Fig. 2.2: Hebrew alphabet from Folio 68r of <i>Champ Fleury</i> Reduced in scale (From Gallica.fr f. 152)	70
Fig. 2.3: Corps 6 from the <i>Cabinet des Poinçons de l'Imprimerie Nationale</i> , 1950 (Actual size).....	75
Fig. 2.4: Partially Assembled alphabet of the corps 6 Hébreu Actual Size (x = 2.0 mm) Imprimerie Nationale.....	75
Fig. 2.5: Corps 6 Hébreu Enlarged x1.5 Imprimerie Nationale	75
Fig. 2.6: Hb1 (S) The first Le Bé Square Sephardic as a comparison.....	75
Fig. 2.7: Specimen of the Corps 8 from the <i>Cabinet des Poinçons de l'Imprimerie Nationale</i> , 1950 (Actual size).....	76
Fig. 2.8: Partially assembled alphabet of the Corps 8 from the <i>Cabinet des Poinçons de l'Imprimerie Nationale</i> , 1950 (Actual size).....	76
Fig. 2.9: The two alternate Hebrews used in the Estienne editions (Enlarged to common size).....	80
Fig. 2.10: Hb1(S): Assembled alphabet enlarged view to approx. 7 mm x-height as a comparison.....	80
Fig. 2.11: Jewish marriage document or Ketubah, produced in Venice in 1612 (St John's College Library, Cambridge MS N.34 539).....	87
Fig. 2.12: Assembled alphabet from MS CL.IX Codex XLII, enlarged (Bibliotheca, Fondazione Querini Stampalia, Venice). 87	87
Fig. 2.13: Incomplete assembled alphabet from the Rylands Haggadah, Spain or Catalonia, mid-fourteenth century.	88
Fig. 2.14: Hb1(S) from NAF 1665 folio 11. A setting from Alvise Bragadin's edition of the <i>Mishneh Torah</i> , Venice, 1550. See BL shelfmark 1918e1, unnumbered folio containing text from Chapter 5 of <i>Chaluchat Yesodi HaTorah</i> , with the Migdal Oz Commentary by Rabbi Shem-Tov ben Abraham Ibn Ga'on.	88
Fig. 2.15: Specimen of Hb1(S) from the <i>Mishneh Torah</i> , Giustiniani, Venice 1550 Title page recto (BL 1918e4).....	88
Fig. 2.16: Specimen of Hb1(S) from the title page of <i>Machzor Helek Sheni</i> , Bragadin, Venice 1599. (BL 1917f4).....	88
Fig. 2.17: Hebrew text from the 1500 proposed Polyglot Bible, printed by Aldus Manutius, Venice c. 1501 (By permission of Martin Davies)	90
Fig. 2.18: Hebrew alphabet from the <i>Introductio utilissima hebraice discere Cupientibus</i> , Aldus Manutius, 1500 (Württembergische Landesbibliothek Stuttgart, Signatur: B hebr. 1516 01)	91
Fig. 2.19: Hebrew text from the Soncino Polyglot Torah printed by Eliezer ben Gershon Soncino in Constantinople in 1546 Actual size (From the Hebrew University Digitized Book Repository).....	91
Fig. 2.20: The Bomberg Moyenne as used in the Plantin 1566 Hebrew Quarto Bible.....	91
Fig. 2.21: The Le Bé specimen of HB1 (S) (From NAF 4528 f.1.)	92
Fig. 2.22: Hb1(S): Assembled alphabet at actual size = approx. 2.7 mm (From NAF 4528 f.1.)	94
Fig. 2.23: from NAF 4528 folio 1. Original size showing lower specimens (Actual size)	97
Fig. 2.24: Comparison of Rabbinical types Hb2 (R) to HB5 (R) and Hb 7 (R) – Enlarged about 2x.....	97
Fig. 2.25: Hb2 (R) complete alphabet enlarged to approximately 10 mm appearing size.	98
Fig. 2.26: Hb2 (R) complete alphabet at actual appearing size (2.00 mm x height).	98
Fig. 2.27: Hb2 (R) from <i>Be'ur al HaTorah</i> , Venice, Giustiniani, 1545 Title Page (BL 1968d16)	99
Fig. 2.28: Hb2 (R) from <i>Divrei Shelomo</i> , Venice, Zanetti, 1598 .Title Page.(UCL SC, SR Mocatta 1595-96 LS).....	99
Fig. 2.29: Hb3 (S) shown at actual size from NAF 4528 f. 2.....	101
Fig. 2.30: Hb3 (S) shown enlarged to x-height of approximately 10 mm	101
Fig. 2.31: Hb4 (S) Pointed setting with cantillation marks from Rés X 1665 f. 10 (Actual size).....	103
Fig. 2.32: Hb4 (S) from the <i>Mishneh Torah</i> , Venice, Giustiniani, 1550. (BL 1918e4).....	106
Fig. 2.33: Hb4 (S) from <i>Mishneh Torah</i> , Venice, Bragadin, 1550 (BL, 1918e2)	106

Fig. 2.34: Stepped and normal Square Hebrew (hebreeuwsch vierkante Letter) punches from the Athias Cabinet (Drawer 5) (The University of Amsterdam Special Collections)	107
Fig. 2.35: Stepped and normal Rashi Script punches from the Athias Cabinet (Drawer 5). (The University of Amsterdam Special Collections)	108
Fig. 2.36: Diagram showing stepped punch with and without accent attached (From <i>Fournier's Manuel Typographique</i> Plate IV, items 10 and 11)	108
Fig. 2.37: ST11 Reale Romaine by Hendrik van den Kerre showing lower case e stepped punch.....	108
Fig. 2.38: ST49 Jolie Grecque Granjon showing lower case character stepped punch with four accents	109
Fig. 2.39: Hb4 (S) as shown on the title page of Guillaume Postel's <i>Candelabrici typici in mosis tabernaculo isusu divino expressi brevis ac dilucida interpretatio</i> . Venice, 1548.	109
Fig. 2.40: Hb4 (S) Assembled alphabet from NAF 4528 f. 2 enlarged to approx. 10 mm x-height.....	110
Fig. 2.41: Hb4 (S) Assembled alphabet from NAF 4528 f. 2 (Actual size).....	110
Fig. 2.42: Comparison of Hb 1 (S) and Hb4 (S).....	110
Fig. 2.43: Hb5 (R) Complete assembled alphabet: to approximate appearing size of 10mm.....	116
Fig. 2.44: Hb5 (R) Complete assembled alphabet: to actual appearing size of 1.50mm.....	116
Fig. 2.45: Hb6 (S) A detail from the 1550 Bragadin <i>Mishneh Torah</i> showing the alignment between the main text and side commentaries. Also note the situations where certain characters would be kerned. Actual size (BL 1918e1).....	120
Fig. 2.46: Hb6(S) 20 line specimen from <i>Arba'ah Turim</i> , printed by Alvise Bragadin, Venice 1563, p. 122. This same specimen appears in part in NAF 4528, f. 6 (BL, 1920b6)	121
Fig. 2.47: Hb6 (S) Complete assembled alphabet enlarged to 10 mm x-height	121
Fig. 2.48: Hb6 (S) Complete assembled alphabet actual size of 2.1 mm x-height	121
Fig. 2.49: Hb2 (R) (left) and Hb7 (R) (right) compared at 5 mm appearing size.....	123
Fig. 2.50: Hb7 (R) complete alphabet at actual appearing size of 2.00 mm.....	123
Fig. 2.51: Hb7 (S) Specimen at actual appearing size of 2 mm from NAF 4528. f.4	124
Fig. 2.52: Hb7 (S) Specimen at actual appearing size of 2 mm from NAF 4528. f.9v	124
Fig. 2.53: (Left) Printer's mark used on Meir di Parenzo's edition of <i>Sefer HaKuzari</i> , Venice, 1547 and (Right) Printer's mark used on the Meir di Parenzo/Carlo Querini edition of <i>Mishnayot MeSeder Kodashim</i> , Venice, 1549. Both Reduced 60 per cent (BL 1932d10 and 1950c1).....	126
Fig. 2.54: Details of the typefoundry from the <i>Proef van letteren: welke gegooten worden in de nieuwe Haerlemsche lettergieterij van J. Enschedé</i> . 1768. (The UB Frankfurt / StUB Frankfurt am Main HM 6: Em 9.)	130
Fig. 2.55: Hb8 (R) Specimen at actual size from NAF 4528 f.5	131
Fig. 2.56: Hb8 (R) assembled alphabet enlarged to approximate x-height of 10 mm.....	131
Fig. 2.57: Hb8 (R) assembled alphabet at actual size of 1.1 mm	131
Fig. 2.58: Hb9 (S) Specimens from NAF 4528 folio 6 (actual size)	134
Fig. 2.59: Hb9 (S) assembled alphabet enlarged to 10 mm (additional characters taken from the <i>Mishneh Torah</i> , Bragadin, Venice, 1550)	135
Fig. 2.60: Hb9 (S) assembled alphabet at actual size of 3.1 mm	135
Fig. 2.61: Hb9 (S) from the <i>Mishneh Torah</i> , Bragadin, Venice, 1550 (BL 1918e3)	135
Fig. 2.62: Hb10 (S) Complete assembled alphabet to enlarged x-height of size of 10 mm. From Le Bé specimen and Machzor (Prayer book), Bragadin and di Gara, Venice, 1599.....	138
Fig. 2.63: Hb10 (S) Complete assembled alphabet at actual size of 4 mm x-height. From Le Bé specimen and Machzor (Prayer book), Bragadin and di Gara, Venice, 1599	138
Fig. 2.64: Hb 10 (S) Specimen from Bragadin and Di Gara's Machzor, Venice, 1599 (BL ORB 30/171)	139
Fig. 2.65: Hb10 (S) Portion of specimen from Johann Berner's Specimen Characterum, Frankfurt am Main, 1622 (From <i>Type Specimen Facsimiles</i> 1, 1963	141
Fig. 2.66: Hb10 (S) Specimen from Hugh Broughton, <i>Daniel with a Brief Explanation</i> , Daniel Averi, Hanau, 1607, Actual size (BL 1003.b.9.(1.)	141
Fig. 3.1: Plan de Bâle, c. 1550 by Germain Hoyau and Olivier Truschet. La Grosse Escriptoire marked in red circle and book trade areas marked in yellow	148
Fig. 3.2: Albert Lenoir, Plan archéologique de Paris: feuille XIV (Cartes et Plans - GE D- 6958 Bibliothèque nationale de France) Maison de la Grosse Escriptoire marked in red circle.....	149
Fig. 3.3: Renouard, Plan Partiel des Quartiers de l'Université, 1898. Location of the Maison de la Grosse Escriptoire marked in red circle	150
Fig. 3.4: Wood engraving from <i>Costumes exotiques</i> , published by Guillaume I Le Bé in 1585 (BnF - Recueil de Gravures sur bois Ea 79 rés., F. 017522) Note the impressum and address for Le Bé at the bottom.	157
Fig. 3.5: Page from Jean Cousin, <i>La vraye science de la pourtraicture descrite et démontrée</i> , Paris: Guillaume Le Bé, 1671. Reduced 70 per cent (From Wellcome Library Closed stores EPB Suppl. C 60120/C).....	158
Fig. 3.6: Page from <i>Observations sur le traité historique et critique de M. Fournier le Jeune</i> , 1762	161
Fig. 3.7: Tabular list of the Le Bé Music types (From Laurent Guillo, <i>Pierre I Ballard et Robert III Ballard, imprimeurs du roy pour la musique 1599-1673</i> , p. 209)	162

Fig. 3.8: Two methods of composition used for music types (By permission of Laurent Guillo, <i>Pierre I Ballard et Robert III Ballard, imprimeurs du roy pour la musique 1599-1673</i> , p. 229) Left: composition en emboitage and right: composition en juxtaposition	163
Fig. 3.9: Music types attributed to Guillaume I Le Bé from J-B Wekerlin (Actual size)	166
Fig. 3.10: Gessner 1743 Hebrew type Case. From <i>Der in der Buchdruckerei wohl unterrichtete Lehr-Junge</i> . BL 11899.bb.4.	174
Fig. 3.11: Ernesti 1733 Hebrew type Case. From <i>Die Wol-eingerichtete Buchdruckerey</i> . BL 53.b.28	175
Fig. 3.12: Johnson's <i>Typographia</i> 1824, Hebrew upper, lower and common type cases. From the Google Books digitised version.....	176
Fig. 3.13: Hb11(S) Complete assembled alphabet from the specimen at actual x-height of 2.5 mm.	179
Fig. 3.14: Hb11(S) Complete assembled alphabet from the specimen (MA72). Actual size. This specimen contains more sorts than are shown in the NAF 4528 specimen. Note the separate accents (Nikkud) and punctuation. (Museum Plantin-Moretus/Prentenkabinet).....	179
Fig. 3.15: Hb11(S) Complete assembled alphabet from the specimen enlarged to approximate x-height of 10 mm.....	179
Fig. 3.16: Hb11(S) Matrices and label. Reduced approximately 77% from original width of 21 cm. (Museum Plantin-Moretus/Prentenkabinet)	181
Fig. 3.17: Hb11(S) Colophon from <i>Cantica Eruditionis</i> . BL (1982c36(2)). The Hebrew gives the printer's names (Guillaume Morel), date in the Hebrew calendar (the month of Cheshvan 1558) and place of printing (Paris). The date in roman numerals is one year later (1559).....	182
Fig. 3.18: Hb11(S) Text specimen from Gilbert Génébrard, <i>De Sancta Trinitate</i> , Jean Bienné, Paris 1569, from Renouard, <i>Répertoire des Imprimeurs parisiens</i> , plate B (II) 38.....	182
Fig. 3.19: Examples of the 15 mm display Hebrew from the Bragadin <i>Mishneh Torah</i> , Venice, 1550 (BL 1918e2) (Reduced)	185
Fig. 3.20: Example of 16 mm display type from 1606 Venice <i>Hagadah</i> . (Reduced)	186
Fig. 3.21: MA6 Reduced 50 per cent (Museum Plantin-Moretus/Prentenkabinet).....	188
Fig. 3.22: ST50 Reduced 50 per cent (Museum Plantin-Moretus/Prentenkabinet)	188
Fig. 3.23: Microscopically enlarged photos of MA6 and ST50, showing the aleph, bet and dalet. Enlarged 2x (Museum Plantin-Moretus/Prentenkabinet)	189
Fig. 3.24: Alphabet from the matrices for MA6, Actual Size (Museum Plantin-Moretus/Prentenkabinet).....	190
Fig. 3.25: Specimen from the <i>Biblia Hebraica</i> , Antwerp, Plantin, 1580, Actual Size (BL 1942g14).....	191
Fig. 3.26: MA 40 made from ST50, Actual size (Museum Plantin-Moretus/Prentenkabinet).....	194
Fig. 3.27: Microscopically enlarged characters from MA40 (Photos By permission of Fred Smeijers and the Museum Plantin-Moretus/Prentenkabinet)	195
Fig. 3.28: A hand pump drill and its operation from Hiscox, <i>Mechanical Movements, Powers, Devices and Appliances</i> , 1914	195
Fig. 3.29: Casting bill for MA40 and MA83c from the Archief 153, f. 39 Reduced 70 per cent (Museum Plantin-Moretus/Prentenkabinet)	196
Fig. 3.30: Hb13 (S): Specimen from NAF 4528 f. 13	197
Fig. 3.31: Hb13 (S): Full assembled alphabet from the MA40 matrices (Museum Plantin-Moretus/Prentenkabinet).....	197
Fig. 3.32: Hb13 (S): Assembled partial alphabet from the MA40 matrices (Museum Plantin-Moretus/Prentenkabinet)	198
Fig. 3.33: Hebrew type case layouts from Lefevre, <i>Guide Pratique du Compositeur d'Imprimerie</i> , Paris 1855	198
Fig. 3.34: Pointed Hebrew composition from Lefèvre: Step 1.....	199
Fig. 3.35: Pointed Hebrew composition from Lefèvre: Step 2.....	199
Fig. 3.36: Pointed Hebrew composition from Lefèvre: Step 3.....	199
Fig. 3.37: Pointed Hebrew composition from Lefèvre: Step 4.....	200
Fig. 3.38: Pointed Hebrew composition examples assembled from the Plantin Polyglot Bible (BL 6.h.4-11.) Enlarged 280 per cent.....	201
Fig. 3.39: Hb13 (S) Diagram of Body size, x-height and line spacing from the Plantin Polyglot Bible. Actual size (BL 6.h.4-11.)	202
Fig. 3.40: Hb13 (S) Example from the <i>Biblia Regia</i> , Antwerp, 1568-73, (BL 6.h.4-11.).....	203
Fig. 3.41: Specimen of Hebrew No. 2 from <i>Spécimen des types français et étrangers de l'imprimerie Nationale</i> , 1855 Actual Size (By permission of Mme Nelly Gable, Le Cabinet des Poinçons).....	204
Fig. 3.42: Partially assembled alphabet from <i>Spécimen des types français et étrangers de l'imprimerie Nationale</i> , 1855 Actual Size (By permission of Mme Nelly Gable, Le Cabinet des Poinçons).....	204
Fig. 3.43: MA 18 Matrices. Front view. Reduced 60 per cent (Museum Plantin-Moretus/Prentenkabinet)	207
Fig. 3.44: MA 18 Matrices. – Rear view. Reduced 60 per cent (Museum Plantin-Moretus/Prentenkabinet).....	207
Fig. 3.45: HB14 (S): Assembled alphabet enlarged to 10 mm appearing size	208
Fig. 3.46: HB14 (S): Assembled alphabet at actual size.....	208
Fig. 3.47: HB14 (S): Assembled alphabet of MA 18 (Museum Plantin-Moretus/Prentenkabinet).....	208
Fig. 3.48: HB14 (S): Le Bé specimen from NAF4528 f. 11 (actual size).....	209

Fig. 3.49: MA 18 as used in the 1753 <i>Biblia Hebraica</i> , Paris. (By courtesy of the John Rylands University Library, Manchester, SC2407E).....	210
Fig. 3.50: Double Pica Hebrew from 1695 OUP <i>Specimen of the several sorts of letters</i> (By permission of Lambeth Palace Library YC911 4.01).....	210
Fig. 3.51: Hebrew Corps 22 from the 1858 <i>Epreuves des Caractères, Adophe René, Fonderie Générale</i> Actual size (St Bride Printing Library).....	211
Fig. 3.52: Hebrew 15207 with and without vowels from the 1924 Deberny & Peignot specimen book. Actual size (Bibliothèque Forney, Paris).....	211
Fig. 3.53: Hb 15 (S): Complete set of punches for ST 55 showing the image end. Slightly reduced in size (Museum Plantin-Moretus/Prentenkabinet).....	214
Fig. 3.54: Hb 15 (S): Selected punches from ST 55 showing differing punch heights and finish. (Museum Plantin-Moretus/Prentenkabinet).....	215
Fig. 3.55: Hb 15 (S): Assembled alphabet from the Le Bé specimen enlarged to about 5 mm appearing size.....	215
Fig. 3.56: Hb 15 (S): Assembled alphabet from the Le Bé specimen at actual size.....	215
Fig. 3.57: Hb 15 (S): Assembled alphabet Actual size (Museum Plantin-Moretus/Prentenkabinet).....	215
Fig. 3.58: Hb 15 (S): Setting specimen from the 1573 Plantin <i>Biblia Hebraica</i> . (By permission of the UCL Special Collections SR Mocatta 1573 B4).....	216
Fig. 3.59: Hb 16 (R) Specimens from NAF 4528 folio 9v (Left and top), Rés X 1665, folio 21v (centre) and the 1599 MPM specimen (right) The PM specimen has an annotation by Guillaume II Le Bé.....	218
Fig. 3.60: Hb 16 (R): Complete assembled alphabet enlarged to 5 mm x-height.....	218
Fig. 3.61: Hb 16 (R): Complete assembled alphabet at actual size of 1 mm x-height.....	218
Fig. 3.62: Detail of semi-cursive Hebrew from Lisbon Pentateuch. Actual Size (From Freimann and Marx, <i>Thesaurus typographiae Hebraicae saeculi XV, plate B19.8</i>).....	219
Fig. 3.63: (Left) Initial letter Bet engraved by Ballaing from the <i>Index characterum Typographiae</i> (No. 3) (Actual Size) Right: Initial letter Bet from the Paris Polyglot of Le Jay of 1645. (Actual Size) (By permission of the MPM and the John Rylands Library, Manchester).....	221
Fig. 3.64: Initial letters from Venice Hagadah 1609, printed by Israel ben Daniel Zifroni (Actual Size) From <i>Seder Hagadah shel Pesach, Venetsyah 369 = The Passover Haggadah</i> , Venice 1609. The original is in the Jewish National and University Library in Jerusalem.....	221
Fig. 3.65: Hb 17 (S) Unretouched Assembled alphabet from NAF 4528 folio 14v-15 (Reduced 50 per cent).....	222
Fig. 3.66: Hb18 (R) Rabbinique du Onze from Adolphe René, <i>Epreuves de Caractères</i> , 1858.....	224
Fig. 3.67: Hb18 (R): Le Bé Specimen shown at actual size. (NAF f.10).....	224
Fig. 3.68: Type specimen of Targum to the Book of Earlier Prophets from Bible printed by Samuel d'Ortas in Leiria in Portugal, dated 1494. Slightly reduced (From Freimann, <i>Thesaurus typographiae Hebraicae saeculi XV</i> , 1969, Plate B27, 5).....	225
Fig. 3.69: Hb18 (R) Example from <i>Harmonie du Monde</i> . Jean Macé, Paris 1579 (BL 692.f.17. from the Epistre section).....	226
Fig. 3.70: MA135a strikes (Museum Plantin-Moretus/Prentenkabinet).....	227
Fig. 3.71: MA135a specimens (Museum Plantin-Moretus/Prentenkabinet).....	227
Fig. 3.72: Hb18 (R): Assembled alphabet from the Le Bé specimen enlarged to 10 mm appearing size.....	227
Fig. 3.73: Hb18 (R): Assembled alphabet from then Le Bé specimen at actual size.....	227
Fig. 3.74: Alphabet Rabbinique from the Imprimerie Nationale (<i>Notices sur les Caractères Étrangers anciens et modernes</i> , Fossey, 1927).....	228
Fig. 3.75: Hb19 (S) Assembled alphabet enlarged to 8 mm appearing size.....	230
Fig. 3.76: Hb19 (S) Assembled alphabet at actual size.....	230
Fig. 3.77: Hb19 (S) Specimens from NAF4528 folios 11v (Left) and 12v (Right) Actual size.....	231
Fig. 3.78: Hb19 (S) Specimens from the Delacolonge specimens of 1773 Actual size.....	231
Fig. 3.79: Example of Hebrew cursive script (Yiddish) from Birnbaum, <i>The Hebrew Scripts</i> , Vol II.....	233
Fig. 3.80: Example of Hebrew cursive script alphabet from Birnbaum, <i>The Hebrew Scripts</i> , Vol II.....	233
Fig. 3.81: Specimen of Narkis Tami Light (Specimen from Authors' collection).....	233
Fig. 3.82: Hb20 (R) Assembled specimen from NAF 4584 F. 16v-17 (Actual size).....	234
Fig. 3.83: Hb21 (S) Assembled specimen from NAF 4584 F. 16v-17 (Actual size).....	236
Fig. 3.84: Hb22 (R). The full specimen (NAF 4528 f. 13) Actual size.....	238
Fig. 3.85: The Rabbinique du Treize from the Fonderie Adolphe René, 1855 (Actual size).....	239
Fig. 3.86: Jacob ben Asher's <i>Tur Orach Chayim</i> . Printed by Abraham d'Ortas in Leiria, 1495. (From Freimann, <i>Thesaurus typographiae Hebraicae saeculi XV</i> , Plate B29.2).....	239
Fig. 3.87: Hb22 (R) Assembled alphabet from NAF 4528 folio 13. Enlarged to 10 mm appearing size.....	240
Fig. 3.88: Hb22 (R) Assembled alphabet from NAF 4528 folio 13. (Actual size).....	240
Fig. 4.1: Hb23 (S) Assembled alphabet actual size.....	243
Fig. 4.2: Hb23 (S) from the title page of <i>Sefer HaShorashim</i> , printed by Marco Antonio Giustiniani, Venice, 1546, Actual size (UCL Special Collections, SR Mocatta Quarto 1546 K4/1-2).....	243

Fig. 4.3: Hb23 (S) from <i>Sefer HaShorashim</i> , printed by Marco Antonio Giustiniani, Venice, 1546, (UCL Special Collections, SR Mocatta Quarto 1546 K4/1-2)	243
Fig. 4.4: MA 34 Matrices Actual size (Museum Plantin-Moretus/Prentenkabinet)	246
Fig. 4.5: Microscopic examination of the matrices for kapf, bet, shin, tav, samekh and ayin from MA 34. Photographs by Fred Smeijers and Museum Plantin-Moretus/Prentenkabinet (Enlarged 800 per cent)	247
Fig. 4.6: MA34 (Inventaris matrizen I and II) Actual size (Museum Plantin-Moretus/Prentenkabinet)	248
Fig. 4.7: Types D and E display types as used by Bomberg. From Kalman, <i>The Book craft of Daniel Bomberg's Press in Venice in the first Half of the 16th Century</i> , 1992, p. 103.....	249
Fig. 4.8: Hb24 (S) Assembled alphabet from specimen (Actual size).....	250
Fig. 4.9: Assembled alphabet from <i>Introductio utilissima hebraice discere cupientibus</i> , Aldus Manutius, 1500	251
Fig. 4.10: Hb24 (S) as used in the <i>Sefer Yuchasin</i> , Proslitz, Cracow, 1580. Actual size (From Hebrewbooks.org (The Chaim Elozor Reich / Renaissance Hebraica Collection)	251
Fig. 4.11: Hb25 (S) Assembled alphabet Actual size from the Le Bé specimen.....	254
Fig. 4.12: Detail from 1494 <i>Arba'ah Turim</i> , Constantinople, 1494 (From the Hebrew JNUL Digitized Book Repository).....	255
Fig. 4.13: Details from <i>Hamishah Humshe Torah</i> , Avraham Usque, Ferrara, 1554 (BL 1944.f.1)	255
Fig. 4.14: Hb26 (S) Assembled alphabet from the Le Bé specimen (Actual size)	256
Fig. 4.15: Detail from <i>Rosh Emunah</i> , Constantinople, Nachmias and Caspota, 1506 (From the Hebrew JNUL Digitized Book Repository)	256
Fig. 4.16: Hb27 (S) Specimen from 1665 f. 4	259
Fig. 4.17: Hb27 (S) Assembled alphabet from specimen and <i>Thesaurus Linguae Sanctae</i> , Geneva, Pierre de la Rouvière, 1614 (From the Google Books digital version)	259
Fig. 4.18: Alphabet from <i>Elementale Hebraicum et Chaldaicum</i> , Gießen, Kaspar Chemlin, 1619. (From the Freimann Collection of the Frankfurt University Library)	260
Fig. 4.19: Hb27 (S) Portion of specimen from Johann Berner's <i>Specimen Characterum</i> , Frankfurt am Main, 1622 (From <i>Type Specimen Facsimiles 1</i> , 1963)	260
Fig. 4.20 Alphabet from <i>Menonsis Hannekenii Grammatica linguae Hebraeae</i> , Christoph Wust, Frankfurt, 1676 (The Freimann Collection of the Frankfurt University Library)	261
Fig. 4.21: Hb28 (S) Assembled alphabet from 1665 folios 4 and 5, <i>Alphabetum Hebraicum 1544 and the Duodecim Prophetae</i> , 1543 (BnF Inv Rés X 2603 and 2606)	263
Fig. 4.22: Hb28 (S) specimen from Rés X 1665 f. 4 (Actual size)	263
Fig. 4.23: Page 95 from the <i>Duodecim Prophetae</i> , 1543, Joel (Lambeth Palace Library, E15.1543.DP)	264
Fig. 4.24: Hb27 (S) Portion of specimen from Johann Berner's <i>Specimen Characterum</i> , Frankfurt am Main, 1622 (From <i>Type Specimen Facsimiles 1</i> , 1963)	265
Fig. 4.25: Page from <i>Machzor mi-Khol HaShanah</i> , Hanau 1624 Actual size (BL 1973c32)	265
Fig. 4.26: Hb29 (S) Assembled alphabet from Le Bé specimen and <i>Rudimenta Hebraicae Linguae</i> , Henri Estienne, Geneva, 1567 (BL 621.i.8).....	267
Fig. 4.27: Hb29 (S) Specimen from 1665 folio 4.....	267
Fig. 4.28: Hb29 (S) Twenty-line setting from <i>Rudimenta Hebraicae Linguae</i> , Henri Estienne, Geneva, 1567 (BL 621i8)	268
Fig. 4.29: Hebrew vowel combinations, (From OUP Archives, OUP/PR/25)	269
Fig. 4.30: Biblical Hebrew setting schema for metal type. (By permission of Scott-Martin Kosofsky)	272
Fig. 4.31: Specimen from Le Bé 1665 f. 4	274
Fig. 4.32: Hb30 (S) Assembled alphabet from Le Bé 1665 f. 4 and <i>Liber Psalmorum Davidis</i> , Geneva 1556 (From e-rara.ch Bb 515).....	274
Fig. 4.33: Specimen of Hb30 (S) (seen on the bottom line of text) from the 1543 Estienne <i>Alphabetum Hebraicum</i> . Actual size (From BSB L.as.123)	275
Fig. 4.34: Specimens of Hb30 (S) from <i>Franciscus Junii Grammatica hebraeae linguae</i> , Geneva, Jean II de Tournes, 1596 Actual Size (From e-rara (Universitätsbibliothek, Basle, FB X22:1)	276
Fig. 4.35: Hb31 (R) Alphabet from <i>Alphabetum Hebraicum</i> , Robert Estienne, Paris, 1539, p. 5 (BnF Rés-X-1662)	277
Fig. 4.36: HB31 (R) Le Bé specimen from 1665 folio 4	278
Fig. 4.37: HB31 (R) Detail of 20 lines from Hosea, <i>Duodecim Prophetae</i> , Robert Estienne, Paris, 1539 (BnF Rés-X-NFA 3)	278
Fig. 4.38: Hb10(S) Assembled alphabet	282
Fig. 4.39: Samples of headings from third Bomberg <i>Biblia Rabbinica</i> of 1548 (Actual size)	282
Fig. 4.40: Full Page from Bomberg <i>Biblia Rabbinica</i> of 1548, showing the sections reproduced on 1665 Folios 7 and 9v Reduced 70 per cent (Leo Baeck Library).....	283
Fig. 4.41: Full Page from Bomberg <i>Biblia Rabbinica</i> of 1548, showing the sections reproduced on 1665 Folios 7v and 9 Reduced 70 per cent (Leo Baeck Library).....	284
Fig. 4.42: Raphael Frank's Frank-Rühl specimen (From <i>Über Hebräische Typen und Schriftarten</i> (Berlin: Schriftgiesserei H. Berthold Abt. Privatdrucke, 1926, p. 27)	286
Fig. 4.43: Hb33 (S) Assembled alphabet from Bomberg third <i>Rabbinic Bible</i> 1548 Actual size (Leo Baeck Library)	286

Fig. 4.44: Hb33 (S) Assembled alphabet from Bomberg third <i>Rabbinic Bible</i> 1548 enlarged to x-height of 6.4 mm (Leo Baeck Library)	286
Fig. 4.45: Hb33 (S) Specimen of 20 lines from Bomberg third <i>Rabbinic Bible</i> 1548 Actual size (Leo Baeck Library).....	287
Fig. 4.46: Page from Robert Bellarmine, <i>Institutiones linguae Hebraicae</i> , Vidua & Moretus, Antwerp, 1596 showing possible use of Hb33 (S). Actual size (Freimann Collection of the University of Frankfurt)	287
Fig. 4.47: Hb34 (R) From the <i>Catalogus Letterbeelden Proeven</i> (Museum Plantin-Moretus/Prentenkabinet).....	289
Fig. 4.48: Hb34 (R) From the Specimen Types from Matrices at the Plantin-Moretus Museum, 1954, p. 7	290
Fig. 4.49: Hb34 (R) Assembled alphabet from 1665 folio 8. Actual size.....	290
Fig. 4.50: Hb34 (R) Assembled alphabet from 1665 folio 8. Enlarged about 200%	290
Fig. 4.51: Hb34 (R) Specimen of 20 lines from 1665 folio 8. Actual size.....	290
Fig. 4.52: Hb35 (S) Assembled alphabet from the Le Bé specimen and the Giustiniani <i>Halakhot Gedolot</i> 1548 Actual size (UCLSC, SR Mocatta Quarto 1548 H1)	295
Fig. 4.53: Hb35 (S) Assembled alphabet from Le Bé specimen and Giustiniani <i>Halakhot Gedolot</i> 1548 Enlarged 1.5x (UCLSC, SR Mocatta Quarto 1548 H1)	295
Fig. 4.54: MA 164b strikes Actual Size (Museum Plantin-Moretus/Prentenkabinet).....	296
Fig. 4.55: MA 164c strikes Actual Size (Museum Plantin-Moretus/Prentenkabinet).....	296
Fig. 4.56: Hb35 (S) Proofs from strikes Actual Size (Museum Plantin-Moretus/Prentenkabinet)	296
Fig. 4.57: Hb35 (S) as used in 1548 by Giustiniani (UCL/SC, SR Mocatta Quarto H1).....	297
Fig. 4.58: Hb35 (S) from 1665 folio 16.....	297
Fig. 4.59: Bomberg Jerusalem <i>Talmud</i> , 1523, top part of page 41, showing folios 17 and 17v from Res-X 1665. (Reduced 90 per cent) Note the example of <i>Lettre grise</i> in the right-hand column.	298
Fig. 4.60: MA135c Photograph of strikes Actual size (Museum Plantin-Moretus/Prentenkabinet).....	302
Fig. 4.61: Hb36 (R) From Inventaris van de stempels en matrijzen van het Museum Plantin-Moretus, 1960 (Museum Plantin-Moretus/Prentenkabinet)	302
Fig. 4.62: Hb36 (R) Partial assembled alphabet (Actual size) from Le Bé specimens	302
Fig. 4.63: Hb36 (R) Partial assembled alphabet (Enlarged 2x) from Le Bé specimens.....	302
Fig. 4.64: Example of Hb36 (R) from Bomberg 1548 Third <i>Biblia Rabbinica</i> Actual size (Leo Baeck Library).....	302
Fig. 4.65: Magnified photo of the matrix for shin in the MA24 (Museum Plantin-Moretus/Prentenkabinet)	305
Fig. 4.66: MA24 Full listing of 90 matrices Shows 90 matrices in total Actual size (Museum Plantin-Moretus/Prentenkabinet)	305
Fig. 4.67: HV Kleine Text) MA24 Full listing of 90 matrices (Actual size) Shows 75 matrices in total (Museum Plantin-Moretus/Prentenkabinet)	306
Fig. 4.68: From Harry Carter's Specimen types from Matrices at the Plantin-Moretus Museum, 1954 Actual size Shows 29 characters in total (Museum Plantin-Moretus/Prentenkabinet)	306
Fig. 4.69: MA24 showing complete matrices in their box. Reduced 80 per cent (Museum Plantin-Moretus/Prentenkabinet)	306
Fig. 4.70: Hb37 (S) Specimen 20 line setting from Bomberg <i>Sefer Ketuvim im HaTargum</i> , Venice 1516-17 (UCL/SC, SR Lewis Trust 5).....	307
Fig. 4.71: Hb38 (S) Assembled alphabet from the Le Bé specimens (Actual size)	311
Fig. 4.72: Hb38 (S) Assembled alphabet from the Le Bé specimens (Enlarged 2x).....	311
Fig. 4.73: Hb38 (S) Page from the 1546 Giustiniani <i>Pentateuch</i> (BL 1944b5)	311
Fig. 4.74: 6 mm assembled unattributed alphabet from BL editions.....	312
Fig. 4.75: 3 mm assembled unattributed alphabet from BL editions.....	312
Fig. 4.76: Page from <i>Seder Tefilot mi-khol ha-Shanah</i> , Venice, 1545 showing 3 mm unpointed and 2.5 mm pointed setting Actual size (BL 1973a19)	313
Fig. 4.77: Specimens of the 2.9 mm Hebrew from the <i>Menorat HaMaor</i> , Di Farra, Venice, 1544 Actual Size (BL 1935g8) 313	
Fig. 4.78: Hb39 (S) Assembled alphabet from the Le Bé specimen and the <i>Evangelium secundum Matthaem</i> Actual size (BL 218b12).....	316
Fig. 4.79: Hb39 (S) Assembled alphabet from Le Bé specimen and the <i>Evangelium secundum Matthaem</i> Enlarged 1.5x (BL 218b12).....	316
Fig. 4.80: Hb39 (S) Page from the <i>Evangelium secundum Matthaem</i> Actual size (BL 218b12)	316
Fig. 4.81: Hb39 (S) Page from Gilbert Générard, <i>Hebraicum alphabetum</i> , Martin le Jeune, Paris, 1564 (Gallica.fr French books before 1601; 489.3)	317
Fig. 4.82: Hb40 (S) Assembled alphabet (Actual size)	319
Fig. 4.83: Hb40 (S) Assembled alphabet (Enlarged 2x)	320
Fig. 4.84: Hb40 (S) used as text face from a page from <i>Sefer HaKuzari</i> , Venice, Parenzo, 1547 showing additional extended characters (BL 1932d10).....	320
Fig. 4.85: Hb40 (S) from 1665 folio 20 (Actual size).....	321
Fig. 4.86: Hb41 (S) Assembled alphabet from 1665 folio 15 (Actual Size).....	322
Fig. 4.87: Hb41 (S) Assembled alphabet from 1665 folio 15 (Enlarged 2x).....	322

Fig. 4.88: Hb41 (S) Specimen from 1665 folio 15 (Actual Size)	323
Fig. 4.89: Portion of Page from Johann Buxtorf, <i>Liber Cosri, Continens colloquim seu disputationem de religione</i> , Georg Decker, Basle, 1660. Actual Size (John Rylands University Library, Manchester. Teltscher J193).....	323
Fig. 4.90: Hb42 (S) Assembled alphabet from Le Bé specimen (Actual size)	325
Fig. 4.91: Hb42 (S) Assembled alphabet from Le Bé specimen (Enlarged 2x)	325
Fig. 4.92: Hb42 (S) Le Bé specimen from 1665 folio 15 (Actual size)	325
Fig. 4.93: Hb43 (R) Assembled alphabet from Le Bé specimen (Actual size)	327
Fig. 4.94: Hb43 (R) Assembled alphabet from Le Bé specimen (Enlarged 2x)	327
Fig. 4.95: Hb43 (R) Le Bé specimen from 1665 folio 19v (Actual size)	327
Fig. 4.96: Hb44 (R) Assembled alphabet from Le Bé specimen 1665 folios 19 and 19v (Actual size).....	329
Fig. 4.97: Hb44 (R) Assembled alphabet from Le Bé specimen 1665 folios 19 and 19v (Enlarged 2x).....	329
Fig. 4.98: Hb44 (R) Specimen of 20 lines from Le Bé specimen 1665 folio 19 (Actual size).....	330
Fig. 4.99: Hb44 (R) Specimen of 20 lines from the 1492 Soncino <i>Mishniot</i> From the Hebrew University Digitized Book Repository, F. 1v (Actual size)	330
Fig. 4.100: Hb45 (S) Partially assembled alphabet from <i>Sha'ari Teshevoṭ</i> , Soncino, Fano 1506 (enlarged 2x)	333
Fig. 4.101: Hb45 (S) Partial assembled alphabet from <i>Arba'ah ve esrim</i> , Soncino, Pessaro 1511-17 (enlarged 2x)	333
Fig. 4.102: Hb45 (S) Partial assembled alphabet from <i>Sha'ari Teshevoṭ</i> , Soncino, Fano 1506 (Actual size)	333
Fig. 4.103: Hb45 (S) Specimens from Rés X 1665 f. 19v (Actual size)	333
Fig. 4.104: Hb45 (S) Full page <i>Sha'ari Teshevoṭ</i> , Soncino, Fano 1506 (Actual size) showing the actual specimen from Rés-X-1665, folio 19v	334
Fig. 4.105: Hb45 (S) as used in the <i>Tanach/Bible</i> , Soncino, Pesaro 1511 -1517 (Reduced 70 per cent). The opening verses of Genesis. Reproduction from JNUL Digitized Book Repository	335
Fig. 4.106: Page from <i>Hamishah Humshe Torah</i> , Hans Jacob Henne, Hanau, 1610. Actual Size (BL 3408bbb1)	337
Fig. 4.107: Hb46 (S) Assembled alphabet from Le Bé specimens (Actual size)	337
Fig. 4.108: Hb46 (S) Assembled alphabet from Le Bé specimens (Enlarged 2x).....	337
Fig. 4.109: Hb46 (S) Specimen from 1665 f. 20 Front side (Actual size).....	338
Fig. 4.110: Hb46 (S) Specimen from 1665 f. 20 Rear side (Actual size)	338
Fig. 4.111: Le Bé's Typeface (HB 15 (S)) which was the result of this request.	338
Fig. 4.112: Hb47 (R) Assembled alphabet from Bomberg <i>Sefer HaShorashim</i> , 1529 Actual size (BL 1936e20)	340
Fig. 4.113: Hb47 (R) Assembled alphabet from Bomberg <i>Sefer HaShorashim</i> , 1529 Enlarged 2x (BL 1936e20).....	340
Fig. 4.114: Page containing specimen of Hb47 (R) from 1529 <i>Sefer HaShorashim</i> , Bomberg, reduced 75 per cent (BL 1936e20)	340
Fig. 4.115: Hb48 (S) Specimen from 1665 folio 21 (Actual size).....	341
Fig. 4.116: Hb49 (R) Assembled alphabet from Le Bé specimen (Actual size).....	342
Fig. 4.117: Hb49 (R) Assembled alphabet from Le Bé specimen (Enlarged 2x).....	342
Fig. 4.118: Hb49 (R) 20 line specimen from Le Bé specimen (Actual size).....	342
Fig. 4.119: Hebrew alphabet from the 1550 edition of Palatino's writing book	345
Fig. 4.120: Detail from Jewish gravestone in Padua (Detail of Asher Meshullam tombstone (1.10, d. 1532).	346
Fig. 4.121: Fourteenth-century Ashkenazic scribal and sixteenth-century printing compared (From Adi Stern, <i>Aleph=X, or contemporary Hebrew bad type</i> , 2004)	349
Fig. 4.122: Comparison between Ashkenazic scribal hand and printing type (Friedlaender, <i>Die Entstehung meiner Hadassah-Hebräisch</i> , p. 18) Reduced.....	349
Fig. 4.123: Hb50 (A) Assembled alphabet from <i>Tabula in grammaticen hebraeam</i> , 1516. Actual size (Amsterdam University Library Special Collections, RON A-4732)	352
Fig. 4.124: Hb50 (A) Lines of pointed setting from the colophon of <i>Tabula in grammaticen hebraeam</i> , 1516. Actual size (University of Amsterdam Special Collections, RON A-4732).....	352
Fig. 4.125: Hebrew Alphabet from Reuchlin, <i>De rudimentis Hebraicis</i> , Thomas Anshelm, Pforzheim, 1506, p. 5 (VD16 R 1252) reduced to same size as Hb50 (A)	352
Fig. 4.126: Hb51 (A) Assembled alphabet from Le Bé specimen and Piove di Sacco edition 1475 (Actual size).....	355
Fig. 4.127: Hb51 (A) Le Bé specimen folio 22 (Actual size)	355
Fig. 4.128: Page from MS. MS. Urb. Ebr. 1 in the Vatican library (From Tisserand, <i>Specimina codicum orientalium</i> , 1914) Note highlighted aleph/lamed and yehovah ligatures, and the 'nun afukh' used to fill out lines. (Actual size).....	356
Fig. 4.129: Hb51 (A) Example from Meshullam Cusi's <i>Selihot</i> , c. 1580. From Freimann, <i>Thesaurus typographiae Hebraicae saeculi XV</i> , Plate A3,1. Note the use of both ligatures, one of them possibly damaged	357
Fig. 4.130: Hb51 (A) Example from Soncino's <i>Selihot</i> , c. 1596. Note the highlighted ligatures. Actual size (From Freimann, <i>Thesaurus typographiae Hebraicae saeculi XV</i> , Plate A83,1)	358
Fig. 4.131: Part of page from Wechel's <i>Bibliorum pars tertia</i> , showing the use of Hb51 (A) as initial letters in the margin. (BL 463c8)	359
Fig. 4.132: Hb52 (A) Specimen from Le Bé, Rés. X 1665, folio 22 (Actual size).....	360
Fig. 4.133: Sample from Birnbaum, No. 343 (Actual size).....	361

Fig. 4.134: Detail from f. 43v of MS 2209, 2208 from the Biblioteca universitaria, Bologna. Actual size (From Beit-Arié and Sirat, <i>Codices Hebraicis litteris exarati quo tempore scripti fuerint exhibentes</i> , Manuscript 91, p. 114.)	361
Fig. 4.135: Hb53 (A) Le Bé specimen (Actual Size)	362
Fig. 4.136: Samples of an Ashkenazic semi-cursive Script from Birnbaum, <i>The Hebrew Scripts</i>	362
Fig. 5.1: Major sixteenth-century punchcutters according to Vervliet's <i>Conspectus</i>	365
Fig. 5.2: Comparative output of sixteenth-century punchcutters based on Vervliet's <i>Conspectus</i>	366
Fig. 5.3: Table of Garamont typefaces from the 1730 <i>Inventaire après décès</i>	370
Fig. 5.4: Table of Typefaces from c. 1617 Le Bé <i>Inventaire après décès</i> (AN ET/LXVI/229)	371
Fig. 5.5: Hebrew matrices and punches as listed in Archives nationales ET/LXVI/229	372
Fig. 5.6: Table of Hebrew and Arabic typefaces from Guillaume III Le Bé <i>Inventaire après décès</i> (11 September 1685 ET/LXX/182)	373
Fig. 5.7: Hebrew matrices and punches as listed in Archives nationales ET/LXX/182	374
Fig. 5.8: Table of Le Bé typefaces and their recipients	378
Fig. 5.9: Table of type sizes in the Le Bé typefoundry	379
Fig. 5.10: Evidence from printed editions examined by location based on Jean-François Gilmont's data	382
Fig. 5.11: Publishing centres in the sixteenth century (from Jean-François Gilmont, 'Les Centres de la Production Imprimée', 1992)	383
Fig. 5.12: Publishing centres in the sixteenth century (from the USTC database accessed 04/04/14)	384
Fig. 5.13: Vinograd Summary by Region for the Sixteenth century	386
Fig. 5.14: Signature in Square Sephardic hand of Eliah ben Michael Judah Leon from letter dated 1666. From the Ets Haim Bibliotheek, (EH 47A11). Enlarged to same appearing size as Briot Hebrew fount	393
Fig. 5.15: The largest Hebrew cut by Briot for Menasseh ben Israel compared to Le Bé's texte Hebrew. (By permission of John A. Lane, from <i>Nicolaes Briot and Menasseh ben Israel's first Hebrew types</i>)	393
Fig. 5.16: The title page from the <i>Sefer Tefilot</i> , Menasseh ben Israel, Amsterdam, 1627. (Bodleian Libraries, University of Oxford, Opp. add. 12mo. 107)	394
Fig. 5.17: The Fell Double Pica Hebrew. Actual size (OUP Archives)	395
Fig. 5.18: The Fell Brevier Hebrew Pointed and unpointed text settings. Actual size (OUP Archives)	395
Fig. 5.19: The Fell Brevier Hebrew Alphabet from original set of matrices and additions and replacements. Actual size (OUP Archives)	396
Fig. 5.20: The Fell Nonpareil Hebrew. Actual size (OUP Archives)	396
Fig. 5.21: Hebrews from the 1585 Miklós Kis Amsterdam specimen. Actual Size (From Haiman and Soltész, <i>Nicholas Kis: a Hungarian punch-cutter and printer 1650-1702</i> , 1983)	397
Fig. 5.22: Kanon Hebreuwsch from Drawer 35 of the Athias Cabinet. Actual Size (University of Amsterdam Special Collections)	397
Fig. 5.23: Example of the title page heading from Aaron Wolf Herlingen, <i>Seder Hagadah shel Pesach</i> , Pressburg, 1726 (By permission of Adam Partridge Auctioneers & Valuers, The Cheshire Saleroom, Macclesfield Cheshire) Enlarged from original size.	398
Fig. 5.24: Examples of headings and text from folio 9, Aaron Wolf Herlingen, <i>Seder Hagadah shel Pesach</i> , Pressburg, 1726 (By permission of Adam Partridge Auctioneers & Valuers, The Cheshire Saleroom, Macclesfield, Cheshire)	399
Fig. 5.25: Harry Carter's Bezalel Type (enlarged 4x) From <i>The Palestine Post</i> , December 1945.	401
Fig. 5.26: Sephardic (upper) and Ashkenazic (lower) scribal alphabets compiled from <i>Likut Sifrei Stam</i> (the scribes' handbook) 1998	402
Fig. 5.27: Comparison of Le Bé's Hebrew Sephardic typefaces	403
Fig. 5.28: Comparison of Le Bé's Hebrew Rashi typefaces	404
Fig. App. F1: Page 1 from ET/LVX/161 (Reduced 60 per cent)	546
Fig App. K.1: Face gauge as described by Harry Carter (St. Bride Library)	619
Fig App. K.2: Face gauge with type sizes marked from the Athias Cabinet (Drawer 33) Original size of each brass is about 9 cm. This is most probably from the seventeenth century. (The University of Amsterdam Special Collections)	619
Fig. App. K.3: Illustrations and descriptions from Harry Carter's Typefounder's tools (St. Bride Library)	620
Fig. App. K.4: Illustrations and descriptions from Harry Carter's Typefounder's tools (St. Bride Library)	621

Author's declaration

I declare that, except where explicit reference is made to the contribution of others, that this dissertation is the result of my own work and has not been submitted for any other degree at the University of London or at any other institution.

The copyright of this thesis rests with the author and no quotation from it or information derived from it may be published without the prior written consent of the author.

Signature:

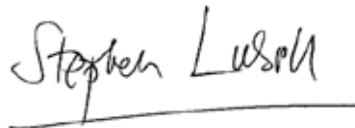
A handwritten signature in black ink that reads "Stephen Lubell". The signature is written in a cursive style and is positioned above a solid horizontal line.

Printed name: Stephen Lubell

Chapter 1: Introduction

In the collections of the Bibliothèque nationale de France in Paris are to be found two documents, or more correctly scrapbooks, which contain a unique collection of type specimens from an important era of French typography.¹ They contain in total a collection of 53 Hebrew, three Greek, six Music, six Roman and one italic types, some cut by Guillaume I Le Bé, and others – both attributed and unattributed – cut by different punchcutters during the sixteenth century.

The first document, Fr. Nouv. Acq. 4528, is held in the Richelieu library in central Paris (in the Département des Manuscrits occidentaux) and is a small book containing 29 leaves with a vellum cover and glued-on endpapers. The dimensions are 19.7 by 13.5 cm (H x W) and the document appears to have entered into the collections of the Bibliothèque nationale in the late nineteenth century, judging from the seal stamped on the pages.² The paper is clearly from the sixteenth century, but it is not possible to make a positive identification of the source of the paper, as the watermark is not visible.

The cover has the following inscription in red ink: 'ESPREVVES | des Lettres que iay taillé | Tant en six ou sept sortes de poinçons | de lettres hebraïques que autres | Lettres, en divers temps et pour diverses | personnes et partie aussi pour moy'.³ On the flyleaf is written in sepia ink 'Ce cayer unique est précieux' and a second inscription in a different hand reads 'Volume de 28 Feuillet; 30 Avril 1889'. The first note is most probably from the sixteenth or seventeenth century, judging from the orthography, and the second note was most probably added by the French bibliographer Henri Omont, who was the first to describe these documents in a published form.⁴

The examples in this document are a presentation of the types cut by Guillaume I Le Bé, beginning with his first Hebrew in 1545 and ending with two Hebrew alphabets dated 1591. There are 18 founts numbered by Le Bé and two unnumbered, but attributed to him by his annotations. Above or below most of the specimens are added handwritten annotations in a sepia-coloured ink in the hand of the first Le Bé.

¹ Vervliet refers to these as 'scrapbooks with holograph annotations and smoke proofs or printed specimens of his own type production'. The term 'scrapbook' – although technically correct from a descriptive point of view – seems inadequate to describe the true nature of these collections ('recueil' in French). Therefore the term 'document' has been used throughout this thesis. See H. D. L. Vervliet, *French Renaissance Printing Types: A Conspectus* (London: The Bibliographical Society, 2010), p. 45

² Pierre Josserand and Jean Bruno, 'Les Estampilles du département des Imprimés de la Bibliothèque Nationale', in *Mélanges d'histoire du livre et des bibliothèques offerts à M. Frantz Calot* (Paris: Librairie d'Agences, 1960)

³ Trials of characters that I have cut as well as six or seven types of punches of Hebrew letter and others types in different times and for different people, as well as for myself. The additional inscription reads 'This unique notebook is of value'.

⁴ Henri Omont, *Specimens de caractères hébreux, grecs, latins, et de musique gravés à Venise et à Paris par Guillaume le Bé, 1545-1592* (Paris: Nogent-le-Rotrou, 1889) and Henri Omont, *Specimens de caractères hébreux gravés à Venise et à Paris par Guillaume Le Bé, 1546-1574* (Paris: Nogent-le-Rotrou, 1887)

It is very clearly a typical sixteenth-century notarial hand.⁵ Someone has also added numbering in a red ink as well as underscoring any mention of the text where Le Bé identifies himself as the creator of the type specimen.

At the rear of this document is attached a handwritten sheet entitled *Maximes pour la Librairie*, in what appears to be an eighteenth-century hand, without any attribution. This text is not relevant to the types presented in the document and was no doubt added at a later date. It lists 24 qualities necessary for a successful bookseller.

The second document, Inv. Réserve X 1665, is held in the rare books departments of the new Bibliothèque François Mitterand in Paris. It is also a small book measuring 19.5 by 12 cm (H x W) of 23 leaves, in a nineteenth-century cardboard binding with an embossed leather spine inscribed with a royal coat of arms, and the stamps inside (*Bibliothecae Regis* and *Bibliothèque Royale*) are probably eighteenth century. The paper is, judging from the watermark, a sixteenth-century paper from Bourges.⁶ Seven of the folios – four separate inserts in total – are bound into the spine and not pasted onto the paper support, thus supporting the idea that the document was rebound at a later date than when it was first assembled.

This document was most probably first catalogued in the *Catalogue des livres imprimés de la Bibliothèque du roi*, 1750 under the title 'Varia typorum hebraïcorum specimina, quibus exarata sunt biblia aut alia opera in plurimis Europae partibus'.⁷ It is *not* a chronological listing of types cut by Le Bé, although it does contain seven specimens repeated from Fr. Nouv. Acq. 4528. The balance of the specimens consists of types from the presses of Robert Estienne, Daniel Bomberg and other unidentified presses of the sixteenth century. This document carries no inscription by Le Bé to identify it, but the hand used for the handwritten annotations is consistent with Fr. Nouv. Acq. 4528. The page opposite folio 1 carries a handwritten note in what appears to be a modern hand: *Notes de Guillaume le Bé and Décrit par H. Omont, Specimens de caractères hébreux gravés à Vénise et à Paris par Guillaume Le Bé, 1887.*

This thesis has as its object the examination and analysis of the Hebrew types in these two documents. The first document (N.A.F. 4528), as previously mentioned, is mostly a chronological record of the those types cut by Guillaume I Le Bé himself, whereas the second document (Rés X 1665), is a compendium of specimens – as well as containing duplicates of Le Bé's types from the first document – by other punchcutters and printers of whom Le Bé had knowledge or opinions.

⁵ Paul Cattin, *Les Ecritures Anciennes: Paléographie Française et Histoire XVIe-XVIIIe siècles* (Bourg-en-Bresse: Les Amis des Archives de l'Ain, 1987)

⁶ Charles Briquet, *Les Filigranes. Dictionnaire historique des marques du papier des leur apparition vers 1282 jusqu'en 1600* (Paris, Geneva: Alphonse Picard et fils, 1907)

⁷ Ellic Howe and Marius Audin, 'French type specimen books', *The Library*, 6 (1951), p. 204. See also Bibliothèque nationale et al., *Catalogue des livres imprimez de la Bibliothèque du Roy* (Paris: Imprimerie Nationale, 1750), p. 6

The impetus for this research came from Professor Hendrik Vervliet, formerly Deputy Curator of the Museum Plantin-Moretus, Library Director Emeritus of the University of Antwerp and Emeritus Professor Book history of the University of Amsterdam, and Dr. Adri Offenberg - formerly curator of the Bibliotheca Rosenthaliana in Amsterdam - both renowned specialists in their own specialist areas of typographic and bibliographic research.⁸ At the outset of the research for this thesis, the intention was to describe and analyse *all* of the typefaces contained in the two documents, whether Hebrew, Roman, Italic, Greek or Music, as neither Professor Vervliet nor Dr Offenberg had the time to pursue this research.

Nevertheless, as the research developed, the choice for the description and analysis was narrowed down to the Hebrew typefaces only. This was due to the need to narrow the research questions and scope of the thesis in as precise a way as possible and also to make the research and analysis more manageable in the time allowed to carry out the research by the funding body, the Arts and Humanities Research Council (AHRC). This was also the opinion of the Upgrade panel consisting of Professor Michelle Brown, Dr. J.F. Coakley and Nigel Roche, then Librarian of St Bride Printing Library in London. Yet it was also apparent that the annotations in the 'non-Hebrew' typefaces contained valuable information as to Le Bé's *Modus operandi* as a punchcutter, his contacts with printers and his wider contributions to the development of type face design in the sixteenth century.

Thus this thesis will not analyse the non-Hebrew typefaces in the same depth as the Hebrews, but *all* the typefaces will be shown in separate appendices, together with their respective annotations and translations. (See Appendices C and D) Where Le Bé made a specific contribution to punch cutting, as with his music types, this will be discussed in chapter three.⁹ It is not the intention of this thesis to ignore the non-Hebrew typefaces, but they do fall beyond the expertise and resources of the present researcher and have been in part dealt with in more detail by other scholars.¹⁰

Yet another constraint on the scope of the research was the need to include historical material relevant to Guillaume I Le Bé's life and professional activities, in addition to the description and analysis of the typefaces themselves. This requirement arose from the background of the writer in book history and the stipulation that the thesis should be as much historical in nature as possible as set by the Institute of Historical Research (IHR), which granted a three year studentship for this PhD thesis. It was

⁸ For an assessment of Vervliet's contribution to typographic history see James Mosley, 'Garamond, Griffo and Others: The Price of Celebrity', *BIBLIOLOGIA An International Journal of Bibliography, Library Science, History of Typography and the Book*, 1 (2006), pp. 38-39, n. 33

⁹ See page 156 of this thesis.

¹⁰ See Jane A. Bernstein, *Print Culture and Music in Sixteenth-Century Venice* (New York: Oxford University Press, 2002), Mary Kay Duggan, *Italian music incunabula: printers and type* (Berkeley: University of California Press, 1992), Mary Kay Duggan, 'Italian music incunabula: printers and typefaces' (PhD, University of California, 1981), Evro Layton, *The sixteenth century Greek book in Italy: printers and publishers for the Greek world, Library of the Hellenic Institute of Byzantine and post-Byzantine studies* (Venice: Istituto ellenico di studi bizantini e postbizantini di Venezia, 1994) and Vervliet's *Conspectus*.

this reason that influenced the writer to carry out research in archives in Paris, Venice, Antwerp and Amsterdam.

It is the purpose of this thesis to describe and analyse the Hebrew types presented in these two Le Bé documents in Paris. The first and only description of these two documents was undertaken by the prolific French Bibliographer Henri Omont (1857-1940) in two publications:¹¹ the first in 1887 described Inv. Réserve X1665 and the second, issued in 1889, described Fr. Nouv. Acq. 4528.¹² Omont listed the types by punchcutter and date and provided selected examples of the specimens. He also provided transcriptions of the annotations. More recently Hendrik Vervliet has listed and described 20 of these Hebrew in his *Conspectus*.¹³

These two documents, it can be said with some certainty, are unique in the history of sixteenth-century typography, as they present type specimens with definite attributions as to the punchcutter, date and use. Hendrik Vervliet has written that ‘a majority of today’s text types, either Roman, Italic, Greek or Hebrew derive directly or indirectly from the type designs conceived or perfected in sixteenth-century France’.¹⁴

This statement requires some refinement in the light of what we now know about the development of Hebrew types in the nineteenth and twentieth centuries and the models used by various punchcutters and later type designers.¹⁵ A good example can be seen in Raphael Frank, the designer of perhaps the most successful Hebrew typeface of the early twentieth century, Frank-Rühl, which first appeared in 1908. He does not mention Le Bé directly as one his models, although he does write that ‘Ich habe bei Entwurf meines Alphabets auf den Duktus der ersten Druckes, ganz besonders den venezianischen, zurückgegriffen’, and from his examples we can surmise that he means the Soncino and Bomberg Hebrew models.¹⁶ Even Henri Friedlaender, the designer of the Hebrew typeface Hadassah which first appeared in 1958, and who was as sensitive as anyone to the history of Hebrew type forms, was concerned to counter the negative influence of what he termed the ‘Didot-Bodoni-Prinzip’ on Hebrew type design. By this he meant the distortion of the true balance between the vertical and horizontal strokes in Hebrew.¹⁷ He was aware of the

¹¹ The Bibliothèque nationale de France catalogue lists nearly 500 publications written by Omont.

¹² Omont, *Specimens de caractères hébreux gravés à Venise et à Paris par Guillaume Le Bé, 1546-1574* and Omont, *Specimens de caractères hébreux, grecs, latins, et de musique gravés à Venise et à Paris par Guillaume le Bé, 1545-1592*

¹³ Vervliet, *French Renaissance Printing Types: A Conspectus, ibid.* See also P. J. Boudot and C. Sallie, *Catalogue des livres imprimés de la Bibliothèque du Roy (Belles Lettres)* (Paris: Bibliothèque nationale (France). Département des imprimés, 1750), p. 6

¹⁴ Vervliet, *French Renaissance Printing Types: A Conspectus*, p. 15

¹⁵ See Stephen Lubell, ‘Hebrew Typography - from the sacred to the mundane’, *Typo/Graphic*, 41 (1990) for a fuller discussion of this theme.

¹⁶ Raphael Frank, *Über Hebräische Typen und Schriftarten* (Berlin: Schriftgiesserei H. Berthold Abt. Privatdrucke, 1926), p. 28 (In the design of my alphabet I have gone back to the weight of the first printed types, in particular the Venetians ...)

¹⁷ Henri Friedlaender, *Die Entstehung meiner Hadassah-Hebräisch* (Hamburg: Kurt Christians und Richard von Sichowsky, 1967), p. 9 ‘hatte der gesteigerte Fett-Fein-Gegensatz das Gefüge des

influence of Le Bé, and knew 'daß es alte gute Schriften gab and daß die neuen Schriften schlecht waren', yet his final design appears to have more in common with the Ashkenazic rather than with the Sephardic model.¹⁸

No less an typographic authority than Stanley Morison wrote that 'nobody has ever cut the Sephardic letters for printers better than he (Le Bé) did and their history in printing since his day is one of decline'.¹⁹ The types created by Le Bé certainly were influential in their time and well beyond, as this thesis will attempt to demonstrate by the analysis of Hebrew editions in the sixteenth century and some from the seventeenth century. The Fell Hebrew types at Oxford University Press are a good example of this influence. Morison commented about them that 'the design of the Spanish or Sephardic style is probably copied from the types supplied to Plantin by Guillaume Le Bé of Paris, which had been used in Leiden from 1584 until 1619 by the Plantin-Raphelengius office'.²⁰ Furthermore, Guillaume I Le Bé was the founder of a dynasty of type foundry which lasted until the mid-eighteenth century. The eight inventories and other documents which have survived provide a clear picture of the types in this foundry, and suggest how wide their use might have been. In the end, the only sure way to draw any conclusions is to examine the primary printed material, given the low rate of survival of the actual punches and matrices.²¹

In addition, the two documents are also unique in that they deal mainly with an 'exotic' typeface, Hebrew, which has never been very closely studied for the period. The other two relevant documents of the sixteenth century which contain the names of punchcutters are the type specimens issued by the Berner Typefoundry in Frankfurt in 1592 and the type specimens sent by Guillaume II Le Bé to Jean Moretus in Antwerp in 1599.²² The Berner 1592 specimen, curiously, does not display any Hebrew types, as Jacob Sabon and Conrad Berner, the successors to the type founder Christian Egenolf and his widow, noted that 'the German and Hebrew types are not quite so highly prized, they and several other Latin types are not shown here, although the best of them are also kept in plentiful stock'.

Hebräischen Schrift ganz gestört ... so daß das Gesamtbild nun in zwei fette streifen, am Kopf und am Fuss der Schrift' (which had totally distorted the heightened thick-thin contrast inherent in the structure of the Hebrew letter .. with the character image reduced to two thick strokes at the head and foot of the character).

¹⁸ *Ibid.* (that there were old 'good' types and that the new ones were poor.)

¹⁹ Oxford University Press, John Fell, and Stanley Morison, *Notes towards a Specimen of the Ancient Typographical Materials principally collected and bequeathed to the University of Oxford by Dr. John Fell, etc.* (Oxford: Oxford University Press, 1953), p. 6

²⁰ Stanley Morison and Harry Carter, *John Fell, the University Press and the 'Fell' types* (Oxford: Clarendon, 1967), p. 233

²¹ James Mosley, 'Documents relating to the foundry of Guillaume Le Bé: a summary and some notes', 2011) I am indebted to James Mosley for letting me have sight of these notes. He lists the following documents: the Le Bé Inventory c.1617, the Le Bé Inventory c.1617, transcribed and edited 1730, the Le Bé Inventory 1685, the Le Bé Memorandum, the Le Bé type specimens 1545–72, the Le Bé type specimens 1546–74, the Le Bé–Moretus collection of fragments c. 1599, and the Inventory of the foundry of Claude Garamond 1561.

²² Vervliet, *French Renaissance Printing Types: A Conspectus*, pp. 19-21

They also note that ‘you may have all manner of strikes, German, Latin, Greek, and Hebrew for hire or for sale, notwithstanding that all are at hand for setting’.²³ The 1599 specimens, now in the Plantin Moretus Museum in Antwerp, are duplicates of the specimens in the two documents in Paris, with additional handwritten comments by Guillaume II Le Bé. There are 30 typefaces on this specimen comprising Hebrew, Latin and Arabic, of which 11 are Hebrew and extracts from the two Paris documents. There is also a specimen of an Arabic typeface dated 1599. The Arabic specimen has the heading ‘Characteres Arabici|In Gallia nunc primùm incisi’ and underneath specifies ‘Gvliemvs Le Bé Parisiensis|incidebat Lutetiae anno 1599’. It is most unlikely that these were cut or commissioned by Guillaume I Le Bé, but by his son Guillaume II and copied from a Robert Granjon original of 1583.²⁴

The research questions addressed in this thesis

At the outset of the research for this thesis, the main research question was formulated as follows: to study the Hebrew types in these (i.e. the Le Bé) documents, classify them according to a modified version of the Proctor-Haebler system, and relate them to extant books or other printed matter for purposes of identification and usage. A secondary objective was to relate the Le Bé types back to the Hebrew types used by the Soncino and Bomberg presses in Italy, and to investigate the Le Bé connections with the *Officina Plantiniana* in Antwerp as well as to other printers. A third but no less important objective was to contextualise the use of these types in the environment of Christian Hebraism in the early modern period and in the environment of Jewish society of the period. Finally a fourth objective was to investigate sixteenth-century Hebrew typefaces from the perspective of historical bibliography and book history by concentrating on the physicality of the typefaces used, their production, distribution, reception and identification in various key works, as well as in the particular way they reflect the society in which they were created.

As with any ongoing project carried out over a long period, these initial objectives have changed. The ‘methodology’ was altered to follow the Vervliet model – which indeed makes use of the Proctor-Haebler system – as seen in his studies of types in the Low Countries and in France.²⁵ The Le Bé connections to the *Officina Plantiniana* were incorporated into the studies of the individual typefaces where

²³ John Dreyfus *et al.*, *Type specimen facsimiles 1-15* (London: Bowes & Bowes; Putnam, 1963), p. 3
The Original is in German

²⁴ ‘Arabic Characters cut for the first time in France/Guillaume Le Bé of Paris cut [them] in Paris in the year 1599’. The original specimens are in the MPM in Arch. 153 in and photographic copies are also kept in the BnF (ResG-Q-144). See also John Dreyfus, *Type Specimen Facsimiles II Nos 16-18* ([S.l.]: University of Toronto Press, 1972), pp. 12-15. For a more detailed discussion of the Arabic specimen, see p. 14-15. See also H. D. L. Vervliet, ‘Cyrillic & oriental typography at the end of the sixteenth century’, in *The Palaeotypography of the French Renaissance: Selected Papers on Sixteenth-Century Typefaces* (Leiden: Brill, 2008), pp. 452-453

²⁵ Vervliet, *French Renaissance Printing Types: A Conspectus*, Hendrik Vervliet and Harry Carter, *Sixteenth-century printing types of the Low Countries* (Amsterdam: Menno Hertzberger & Co.: , 1968)

relevant as these topics had been more fully covered in the writer's MA dissertation.²⁶ The discussion of the Christian Hebraist element was reduced to cover only relevant topics. The discussion of the typefaces increased as it became apparent that space and time would limit the thesis to a study of *only* the Hebrew types found in the two documents.

At an early stage of the work, it was decided to make the analysis of the actual types the prime object of the research. In addition it was decided to integrate the study of the types with a book historical approach and situate Le Bé in the context of his times. Thus other research questions began to appear as the work progressed.

- What was the nature of Le Bé's apprenticeship with Robert Estienne?
- What was Le Bé's role in the cutting of the Estienne Hebrews?
- Why was Le Bé's purpose in going to Venice? Was it by invitation by the printer/publisher Marco Antonio Giustiniani or did he simply go as a qualified journeyman?
- What was the nature of the court case Le Bé brought against the printer Marco Antonio Giustiniani in Venice?
- What were the reasons for Le Bé's six month stay in Rome with Antonio Blado and did he cut any Hebrews there?
- Did Le Bé's family wealth come from his activities as an engraver, paper merchant, or from monies inherited from his family in Troyes or from other sources?
- Why did Le Bé specialize mainly in Hebrew types and what does this say about his relations to Jews or other minority groups, such as the Huguenots? How proficient was he in the Hebrew language and printing conventions and how might he have learned it?
- What were Le Bé's methods of producing his types? What sort of matrices did he supply and what was his method of producing strikes with vowel points, cantillation marks and dagesh points? Did he use counter punches or drills to create the vowels or dagesh points?
- What models did Le Bé use in cutting his types, and why did he cut only types following the Sephardic hand, and never in the Ashkenazic style? This issue is discussed in the sections dealing with the Ashkenazic specimens in NAF 4528.

²⁶ Stephen Lubell, '*The Use of Hebrew in the Antwerp Polyglot Bible*', (London: Institute of English Studies, 2008)

- Did Le Bé function mainly as an engraver and supply matrices (or strikes) to his clients? At what point did these activities metamorphose into what we might properly call a typefoundry, as appears to have happened under the management of his son and successor Guillaume II Le Bé.²⁷
- What were the reasons for the compilations of the two BnF documents? Were they simply personal records or perhaps intended as type specimens for clients?
- What were Le Bé's connections, both business and personal, with fellow engravers, founders, printers, and paper merchants, many of whom had evident Protestant sympathies?

Given the structure of this thesis, these questions are discussed within the context of specific types where they are relevant.

Sixteenth-century printing and the place of Hebrew publishing within it
 Hebrew printing and publishing in the early modern period needs to be viewed from three distinct perspectives:

- Publishing carried out by Jews for Jews
- Publishing produced by Christian Hebraists mainly for Christians
- Publishing aimed at a Jewish audience, yet initiated and financed by Christians

The types cut by Guillaume I Le Bé are to be found within all three of these categories, as the two centres where he was active – Paris and Venice – produced editions for all three types of audience.

The first category, Jews publishing for Jews, catered mainly for the type of works – liturgical, commentary and Biblical – required by Jews for study and worship. As an example, the lists of Hebrew books owned by Jews of in the Jewish community of Mantua from 1595 present a useful index of the types of works that were most common in the private libraries of Jews of that period.²⁸ Roberto Bonfil has written that in Jewish private libraries of Renaissance Italy 'the vast majority of the books that formed part of these collections were liturgical works, works of Biblical exegesis, works dealing with questions of ritual, and especially copies of the Talmud.' He also notes that 'this state of affairs is confirmed by the list of Hebrew works the first publishers chose to publish in the last quarter of the fifteenth and the first half of the sixteenth centuries.'²⁹

²⁷ See page 381 for discussion of this question.

²⁸ Shifra Baruchson-Arbib, *La culture livresque des juifs d'Italie à la fin de la Renaissance* (Paris: CNRS - Centre National de la Recherche Scientifique 2001), p. 50

²⁹ Robert Bonfil, *Jewish life in Renaissance Italy* (Berkeley: University of California Press, 1994), p. 148

The second category, that of publishing carried out by Christians for Christians, is one of the most intriguing phenomena of the sixteenth century and takes us into the area of Christian Hebraism and the scholars who were leading exponents of Hebraic studies in various countries. This can best be described as 'Christendom's rediscovery of Judaism' and was undertaken for a variety of motives, usually religious but occasionally scholarly or antiquarian.³⁰ The works they wrote and edited served a number of purposes: they were aids for learning Hebrew, polemical works for a Christian audience and forerunners of the *Wissenschaft des Judentums* – 'the science of Judaism' in German – which developed in the nineteenth century.

The 'Zeitgeist' in which these works emerged was typical of the Renaissance as 'despite the general distrust of the Jews, by the end of the fifteenth and sixteenth century, a knowledge of their language and a familiarity with their classical sources became respected elements in the new intellectual scene. Some persons wanted to read the Old Testament in its original language ...; other sought techniques in the Jewish medieval commentators to create a more modern biblical exegesis, while others thought that they could discover in the Jews' own text arguments to support the truth of the Christian faith. Still others sought to give grammatical descriptions of all the languages, classical and vernacular, including Hebrew, in terms of the Greco-Latin model.'³¹

The growth of Christian Hebraism led to what one might call a culture of Jewish books without the presence of Jews. Initially, in the early sixteenth century, Jews or converted Jews were needed to teach, edit or write texts. By the end of the century the situation had changed and there were enough scholars available to deal with the more complex of Hebrew works, such as the Kabbalistic texts.³² The physical absence of Jews in many countries made this a necessity. The dearth of skilled Jewish compositors and proof readers caused major problems for some printers of the period, as well as well for readers. Stephen Burnett has written that 'for the vast majority of Christian Hebrew presses it was non-Jewish typesetters and compositors who manufactured Hebrew books' and cites the example of Johannes Buxtorf who had to transcribe a book manuscript from cursive to square Hebrew so that the compositors could read it.³³ In the seventeenth century there is the testimony of Avraham the son of Eliezer Brunschwig, who was involved in the production of the Rabbinical Bible printed by Johannes Buxtorf in Basle³⁴ in 1618. Brunschwig

³⁰ Frank E. Manuel, *The broken staff: Judaism through Christian eyes* (Cambridge, Massachusetts and London, England: Harvard University Press, 1992), p. 1

³¹ Sophie Kessler Mesguich, 'Early Christian Hebraists', in *Hebrew Bible/Old Testament*, ed. by Magnés Sæbø (Göttingen: Vandenhoeck & Ruprecht, 2008), pp. 255-256

³² Manuel, *The broken staff*, p. 68. For a more comprehensive examination of the numbers of Hebrew scholars and the availability of Hebrew texts in Tudor England, see G. Lloyd Jones, *The Discovery of Hebrew in Tudor England: a third Language* (Manchester: Manchester University Press, 1983) and Abraham Schper, 'Christian Hebraists in Sixteenth Century England', University of London, 1944)

³³ Stephen G. Burnett, 'Christian Hebrew printing in the 16th century: Printers, Humanism and the impact of the Reformation', *Helmantica*, 51 (2000), pp. 26-28

³⁴ The English spelling of 'Basle' has been used throughout, excepted for cited works, where the German spelling 'Basel' is used.

complained of the almost total ignorance of Hebrew by the non-Jewish composers and of the many errors they introduced into the text. He lamented the total ignorance of composers who 'ne sont pas Israélites' and who 'n'ont pas vu l'oeuvre de Dieu dès l'enfance et sont hors d'état de lire ou de reconnaître même une lettre de notre langue sacrée'.³⁵ There is no evidence, for example, of any Jews being directly involved in the Robert Estienne Hebrew editions in Paris nor in the production of the Plantin Polyglot Bible of 1569-1572. Yet careful supervision by knowledgeable Hebraists, such as François Vatable or Jean Mercier, or Arias Montano and Franciscus Raphelengius, resulted in extremely accurate productions.³⁶

Hebrew printing in France began about 1518 with the arrival of the Italian 'humaniste hébraïsant' Agostino Giustiniani. He had been responsible for the polyglot Psalms printed in 1516 in Genoa by Petro Porro and has been credited with the renaissance of Hebrew studies in France. He was followed by Gilles de Gourmont (1508-1529), the Estienne dynasty – and in particular Robert I Estienne, Chrétien Wechel (1531-1553), François Gryphe (1532-1542), Claude Chevallon (1532-1536) and his widow Charlotte Guillard (1537-1552), Martin le Jeune (1549-1584), Guillaume Morel (1559-1564), Pierre Vidoue (1522-1543), Louis Blauboom (1531-1537), Simone de Colines (1524-1541) and Gérard Morrhy (1531). Some of these printers will be discussed at greater length in this thesis.³⁷

In Paris, Christian Hebraist printing was quite unique in that a large number of books were printed either totally or partially in Hebrew without the presence of Jews.³⁸ It has been remarked that 'after the expulsion of 1394 only occasionally were there any Jews resident in Paris, and these had no legal status. At last some few Jews obtained permission from Louis XI (1461-83) to reside there, on condition of providing themselves with a license from the police, which it was necessary to renew every two or three months. It was not until about 1500 that the presence of Jews in Paris is again noticed'.³⁹ And Lyse Schwarzfuchs confirms this point when she writes of the post-expulsion period that 'l'hébraïsme français serait désormais chrétien'.⁴⁰

Robert I Estienne produced a Hebrew Bible in two editions: the first in 24 parts in quarto between 1539 and 1546 and the second in sextodecimo between 1543 and 1546. It is of interest to note that Estienne wrote in the introduction to his *Thesaurus linguae sanctae* that 'la grande etait destinée aux rois et autres dirigeants pour qu'il

³⁵ J. Derenbourg, 'L'Édition de la Bible Rabbinique de Jean Buxtorf', *Revue des Etudes Juives*, 30 (1895), pp. 70-78

³⁶ See Anthony Grafton, *The culture of correction in Renaissance Europe* (London: British Library, 2011), pp. 168-178

³⁷ Lyse Schwarzfuchs and Antoine Coron, *Le livre hébreu à Paris au XVIe siècle: inventaire chronologique* (Paris: Editions de la Bibliothèque nationale de France, 2004), pp. 22-44. The years cited are the known years of their activity as printers of Hebrew editions.

³⁸ See David B. Ruderman, *Early Modern Jewry* (Princeton and Oxford: Princeton University Press, 2010), pp. 111-120 for a recent assessment.

³⁹ Cyrus Adler, *The Jewish Encyclopedia*. 12 vols (New York and London: Funk & Wagnalls, 1907) Article on Paris

⁴⁰ Schwarzfuchs and Coron, *Le livre hébreu à Paris au XVIe siècle*, p. 18

puissent en tirer des enseignements, la petite étant plus facilement transportable'.⁴¹ This appears to confirm that Estienne did not have in mind a Jewish readership, but rather a non-Jewish one. It is not certain whether these Parisian Hebrew editions found their way, or were indeed accepted at all, by a Jewish readership. It is worth noting the assessment of Bertram Schwarzbach that 'from an editorial point of view, Robert Estienne's edition of the Bible broke no new ground and was even a regression with respect to the two great Bomberg folio Bibles ... which says much about the sophistication of Hebrew studies in Paris'. He adds that the Bomberg editions were 'dense Hebrew texts for learned Jewish readers, while the vocation of the Paris editors and publishers seems to have been to make more rudimentary Hebrew texts available and legible to Christian readers'.⁴² Yet it is interesting to note how useful the Estienne Hebrew editions were to such a student of Hebrew as Isaac Casaubon, whose copies of the *Prophetæ Minores* are 'virtually alive' with his annotations. Casaubon's own personal library of Hebrew texts was large, and contained a wide range of works, such as the major grammars 'from Kimhi to Levita, from Chevalier to Buxtorf, manuscripts 'including the *Zohar* and a fascicule of the Talmud, Münster's Chaldaic dictionary, Natan Yehiel's *Arukh* and the Santes Pagninus *Thesaurus*, David de Pomis' *Tsemach David*', to name but a few of the volumes which have survived or can be identified from his own lists.⁴³

The third category, those books aimed at a Jewish audience, yet initiated and financed by Christians, are peculiar to the early modern period and very much a product of the society in which these printers operated. In many instances and places, Jews were not allowed to operate presses on their own and thus a Christian was needed to be either the initiator or owner of the press. Such was usually the case in Venice, where for example, Daniel Bomberg, Marco Antonio Giustiniani, Alvise Bragadin, Giovanni di Gara, Carlo Querini and Giorgio di Cavalli were active in Hebrew printing. They were often members of the Venetian Patriciate and commonly employed Jews as editors and compositors. Christopher Plantin, not usually thought of as a Christian Hebraist printer, produced a Hebrew Bible in 1567 aimed at the Jewish populations in what was then called 'Barbarie', which probably included present day Morocco, Tunisia and Algeria. Such was the success of this edition, that Plantin printed an edition of nearly 9,000 copies in a 4to, 8vo and 16mo formats.⁴⁴

⁴¹ *Ibid.*, p. 37

⁴² Bertram Schwarzbach, 'Geddes in France', in *The Bible and the Enlightenment: a case study - Dr Alexander Geddes (1737-1802) : (the proceedings of the Bicentenary Geddes Conference held at the University of Aberdeen, 1-4 April 2002)*, ed. by William Johnstone (London: T & T Clark International, 2004), pp. 81-82

⁴³ Anthony Grafton and Joanna Weinberg, *'I have always loved the holy tongue': Isaac Casaubon, the Jews, and a forgotten chapter in Renaissance scholarship* (Cambridge, Mass. ; London: Belknap, 2011), pp. 71-82

⁴⁴ Leon Voet and Jenny Voet-Grisolle, *The Plantin Press, 1555-1589: a bibliography of the works printed and published by Christopher Plantin at Antwerp and Leiden* (Amsterdam: Van Hoeve, 1980), pp. Vol I, pp. 323 –324

This was a very large edition for this period, when the average print run was in the region of 1000.⁴⁵

It is perhaps no accident that the role of the independent punchcutter and engraver arose chiefly in Italy and France in the sixteenth century, given the relatively centralised nature of French printing in Paris and Lyons and the dominance of Venice as a printing centre. A certain critical mass in terms of numbers is no doubt needed to support specialised trades and professions, and there is good evidence for this view from the period 1450 to 1600 in France. An analysis of the various trades and professions mentioned in Philippe Renouard's sampling of documents from the Archives Nationales and the Bibliothèque nationale shows a large number of booksellers (719) and printers (356), supported by a very small number of punchcutters (8) and type casters (25).⁴⁶ As a comparison, Gedeon Bursa has listed some 925 printers active in Venice in the fifteenth and sixteenth centuries, with Rome at a much lower level of 235.⁴⁷ It can be assumed that the ratio of punchcutters and type founders in Venice would have been similar to the Parisian data.

The implications of this fact are the wide dispersal of similar types across many different printers. Hendrik Vervliet has argued that 'during the fifteenth century the technical processes can be seen as being concentrated, and that a split occurred in the sixteenth century between type founders and printers'. During this second phase, punchcutters worked for different printers, cutting punches and producing matrices – or strikes – to order.⁴⁸ The incunabula model of reproduction appears to have been a situation where each printer supplied his own type. This theory is most closely associated with the work of Konrad Haebler,⁴⁹ although this was contested by Ernst Consentius. A. F. Johnson cast doubt on some of the attributions made by Robert Proctor for the first quarter of the sixteenth century, when he reduced the total number of some 600 different and distinct sixteenth-century typefaces to about 180 types cut in about twenty-five years in the period before 1501.⁵⁰

⁴⁵ See Alan Sangster, 'The printing of Pacioli's *Summa* in 1494: how many copies were printed?', *Accounting Historians Journal*, 34 (2007). See also Angela Nuovo, *The Book Trade in the Italian Renaissance* (Leiden and Boston: Brill, 2013), pp. 99-116

⁴⁶ Philippe Renouard, *Documents sur les imprimeurs, libraires, cartiers, graveurs, fondeurs de lettres, relieurs, doreurs de livres, faiseurs de fermoirs, enlumineurs, parcheminiers et papetiers ayant exercé à Paris de 1450 à 1600*, Société de l'histoire de Paris et de l'île-de-France (Paris: H. Champion, 1901)

⁴⁷ Gedeon Bursa, 'Drucker und Verleger in Italien vor 1601 und ihre Ortschaften', in *La Stampa in Italia nel Cinquecento: atti del convegno, Roma, 17-21 ott. 1989*, ed. by Marco Santoro (Roma: Bulzoni, 1992)

⁴⁸ H. D. L. Vervliet, 'Concentration vs. Specialization in the Technical Printing Professions from the Fifteenth to the Nineteenth centuries', in *Produzione e commercio della carta e del libro secc. XIII-XVIII: atti della "Ventitreesima Settimana di studi" 15-20-aprile 1991 Atti delle "settimane di studi" e altri convegni. Serie II; 23.*, ed. by Istituto internazionale di storia economica F. Datini. Settimana di studi (23rd: 1991: Prato Italy) and Simonetta Cavaciocchi (Firenze: Le Monnier, 1992), pp. 511, 515

⁴⁹ Conrad Haebler, 'Typefounding and Commerce in Type during the early Years of Printing', *Ars Typographica*, III (1926), pp. 32-35

⁵⁰ A. F. Johnson, 'The Supply of Types in the Sixteenth Century', *The Library: The Transactions of the Bibliographical Society*, s4 XXIV (1943), p. 53

Primary and secondary source materials

The *Le Bé Memorandum* was written by Guillaume II Le Bé in 1643 with additional material by Jean-Pierre Fournier added in the mid-eighteenth century. It contains short biographical notices of the major French punchcutters of the sixteenth century and has much useful additional information on the life of Guillaume I Le Bé.⁵¹ The main type specimens of the period are the *Index sive Specimen Characterum Christophori Plantini* of 1567, which has examples of ten Hebrews, cut by Le Bé and issuing from the Bomberg press. The Plantin Folio specimen of 1585 contains four Le Bé types and three Bombergs. The Berner 1592 specimen and the Le Bé –Moretus fragments of 1599 have already been mentioned, in that they mention the names of the punchcutter.

Yet another major primary source is the various inventories kept in the Plantin Moretus archives. These allow us to see in some detail the way the types were catalogued in the *Officina Plantiniana* during the period 1556 to 1652. These inventories list a total of 38 Hebrews, of which ten can be attributed to Le Bé, six to the Bomberg press, one to Garamont⁵² and the rest unidentified.⁵³ This is useful as an example of how Le Bé's types were distributed. The use of Hebrew types (including some by Le Bé) by Franciscus Raphelengius and Johannes Le Maire in the Low Countries during the period 1585 to 1815 has been documented by Fuks and Fuks-Mansfeld.⁵⁴

For sixteenth-century Parisian printing, the investigative work of Philippe Renouard is of primary importance. His studies of the original sources in the Archives nationales and the BnF are a first place to look for relevant documents. His major work is the *Documents sur les imprimeurs, libraires, cartiers, graveurs, fondateurs de lettres, relieurs, doreurs de livres, faiseurs de fermoirs, enlumineurs, parcheminiers et papetiers ayant exercé à Paris de 1450 à 1600* as well as his *Répertoire des imprimeurs parisiens, libraires, fondateurs de caractères en exercice à Paris au XVIIIème siècle*.⁵⁵ Renouard may well have been carrying on the interests of his

⁵¹ Guillaume Le Bé, *Sixteenth-century French typefounders: the Le Bé memorandum*. ed. by Harry Carter (Paris and Oxford: André Jammes, 1967). This document was rediscovered by Miss O. A. Abbott, Stanley Morison's researcher in Paris for over 20 years. She was one of the first researchers to compile documentary evidence on Le Bé's life. See Appendix E, page 518.

⁵² In this thesis I have used the spelling 'Garamont', as used by Vervliet in his œuvre, in place of the more accepted form 'Garamond', except where the cited source used the alternate spelling. For a discussion of the this point see James Mosley, 'Garamond or Garamont?' (2011) <<http://typefoundry.blogspot.co.uk/2011/04/garamond-or-garamont.html>> [Accessed 6 November 2013]

⁵³ M. Parker, K. Melis, and H.D.L. Vervliet, 'Typographica Plantiniana II. Early inventories of punches, matrices, and moulds, in the Plantin-Moretus Archives', *De Gulden Passer*, 38 (1960)

⁵⁴ L. Fuks and R. G. Fuks-Mansfeld, *Hebrew typography in the Northern Netherlands, 1585-1815* (Leiden: Brill, 1984), pp. 11-21

⁵⁵ Renouard, *Documents sur les imprimeurs, libraires, cartiers, graveurs, fondateurs de lettres* and Philippe Renouard, *Répertoire des imprimeurs parisiens, libraires, fondateurs de caractères et correcteurs d'imprimerie: depuis l'introduction de l'imprimerie à Paris (1470) jusqu'à la fin du seizième siècle* (Paris: Libraire A. Claudin, 1898)

ancestor Antoine Augustin Renouard, who in 1837 produced a still usable guide to the Estienne printing dynasty, his *Annales de l'Imprimerie des Estienne*. One could also mention the work of Georges Lepreux, whose multi-volume work *Gallia typographica* builds on the work of Philippe Renouard.

It is also worth mentioning the Anisson-Duperron archive on bookselling and printing in the BnF.⁵⁶ This is described as a 'recueil de documents de tout genre, manuscrits et imprimés, relatifs à la librairie et à l'imprimerie, réunis par le dernier directeur de l'Imprimerie royale'.⁵⁷ Ms. Fr. 22117 contains a series of documents dating from 1583 to 1764 concerning type founding with references mainly to Guillaume II Le Bé and his contemporaries. Ms. Fr. 22189 has various specimens of Hebrews which have attributions to Le Bé, although the precise name of the typefoundry has yet to be established.⁵⁸

The typographic historian Ellic Howe wrote about the Le Bé family and the history of Hebrew typography in general in two important articles in the typographic journal *Signature* in 1937 and 1938.⁵⁹ More recent scholars who have brought to light useful documents are Annie Parent-Charon of the École des Chartes, whose work *Les métiers du livre à Paris au XVIe siècle (1535-1560)* is an important source for archival material in the Archives nationales, especially in the Minutier Central, and Geneviève Guillemot-Chrétien of the Bibliothèque nationale de France for her articles on Garamont.⁶⁰ The major contemporary source for Hebrew printing in sixteenth-century Paris is Lyse Schwarzfuch's *Le livre hébreu à Paris au XVIe siècle: inventaire Chronologique* published in 2004. She has since added similar studies for Hebrew printing in Lyons and Geneva.⁶¹

For primary sources on printing in Venice the picture is more problematic. The classic work is that of Horatio Brown, *The Venetian printing press*, published in

⁵⁶ MS. Français 22061-22193, Collection Anisson-Duperron sur la Librairie et l'Imprimerie.

⁵⁷ From the BnF Catalogue Collectif; Manuscrits et fonds d'archives Département des Manuscrits Français. Français 20256-Français 22265 See also Bibliothèque nationale, Etienne Anisson-Duperron, and Ernest Coyecque, *Inventaire de la Collection Anisson sur l'histoire de l'imprimerie et la librairie, principalement à Paris [formed principally by J. d'Hemery] ... Par E. Coyecque* (Paris, 1900)

⁵⁸ Folio 63 has a 'Hebrieu et Rabbin Sedanois', folio 67 has a 'Hebreu Tremisgiste' and 'Palestine', folio 68 has a 'Hebreu de Gros Romain' and a 'Hebreu de Saint-Augustin', and folio 69 has a 'Rabin de Gros Romain', 'Rabin de Saint-Augustin' and a 'Rabin de Petit Texte'. The handwritten annotation on the cover sheet attributes these typefaces to the Fonderie Fournier Aîné.

⁵⁹ Ellic Howe, 'The Le Bé Family: typefounders, printers, paper merchants, engravers, and writing masters, 1525-1730', *Signature* (1938) and Ellic Howe, 'An Introduction to Hebrew Typography', *Signature*, 5 (1937)

⁶⁰ Geneviève Guillemot-Chrétien, 'Le Testament de Claude Garamont', in *Le livre et l'historien: Etudes offertes en l'honneur du Professeur Henri-Jean Martin*, ed. by Henri Jean Martin and Frederic Barbier (Geneve: Librairie Droz, 1997)

⁶¹ Lyse Schwarzfuchs, *L'hébreu dans le livre à Genève au XVIe siècle* (Genève Librairie Droz, 2011), Lyse Schwarzfuchs, *L'hébreu dans le livre lyonnais au XVIe siècle* (Lyon: ENS Editions/Institut d'Histoire du Livre, 2008), Schwarzfuchs and Coron, *Le livre hébreu à Paris au XVIe siècle*. Note that the older historical spelling of Lyons with an s has been used in this thesis, except where the original text was spelled without.

1891. Brown was perhaps the first historian to mine material from the Venetian Archivio di Stato. In the early years of the twentieth century, Victor Masséna, also known as the Prince d'Essling or the Duca di Rivoli, paid for some eleven researchers to comb through what appears to be the entirety of the Archivio di Stato in Venice for any mention of the words, *printers, engraver or bookseller* during the period 1540 to 1550.⁶² The results of these researches were sent to Masséna in Paris on coded cards and have since disappeared.⁶³ The remaining results of this search are available on a microfilm and this writer was able to view them during a stay in Venice in 2010. It has to be said that the results with regard to documentary evidence from Guillaume I Le Bé's stay in Venice are as yet inconclusive and more material may yet emerge. Regarding the history of Hebrew printing in Venice, the work most commonly cited is that of David Amram, *The makers of Hebrew books in Italy*, but it is unreliable in some respects and needs to be treated with caution.⁶⁴

The description of type as a historical discipline can be said to have started with the work of the American printer scholar Daniel Berkeley Updike, first published in 1922. Updike does discuss Le Bé and notes that 'at his death in 1598, Le Bé was the first engraver of Oriental characters in the world'.⁶⁵ At about the same period, A.F. Johnson also mentioned Le Bé, but without too much detailed discussion on his Hebrews. The same is true of his later work *Type Designs*, published in 1934. The curious fact is that the disciplines of historical bibliography and the history of print and type developed in two divergent streams, one dealing with the history of printing types and the other concentrating on analytical bibliography⁶⁶ or the cataloguing of mainly of Incunabula, for whom the 'question as how type developed were of no concern'.⁶⁷ Vervliet has done much to remedy this situation in his various articles and publications. Yet Hebrew printing requires a particular approach, given the nature of the language, the scripts used, the categories of books published, the mode of distribution and the interaction between Christians and Jews in the production of Hebrew editions. It is this element of book history that this thesis will attempt to integrate into the analysis of the Le Bé Hebrew types and printers who used them.

The other source of primary material with relevance to the life and works of Le Bé is to be found in the archives of Plantin Moretus Museum in Antwerp. Here is a collection of the only remaining punches and matrices produced by him, type

⁶² Archivio di Stato, Venezia, *Stampatori, Ricerca Duca di Rivoli*, bobina 155, busta unica

⁶³ I am indebted to the current holder of this title, V.A. Masséna d'Essling for this information.

⁶⁴ See Michael Terry, *Reader's guide to Judaism* (Chicago ; London: Fitzroy Dearborn, 2000), p. 498

⁶⁵ Daniel Berkeley Updike, *Printing types: their history, forms, and use: a study in survivals*. 3rd ed. (Cambridge, Mass.: Belknap ; London: Oxford University Press, 1962), p. 205 (Vol I)

⁶⁶ For a more detailed discussion of the five main forms of bibliography (Enumerative or Compilative, Bibliography, Historical, Analytical, Descriptive and Textual or Critical) see Neal Harris, 'Analytical bibliography: an alternative prospectus'(2004) <<http://ihl.enssib.fr/siteihl.php?page=55>> [Accessed 8 April 2013]

⁶⁷ Vervliet and Carter, *Sixteenth-century printing types of the Low Countries*, p. 2. For a more in depth discussion of bibliography in its many forms

specimens and the original inventories of the *Officina Plantiniana*. These were examined as part of the doctoral research.

The punchcutter as part of the printing process

The generally accepted view of the origins of printing is that Johann Gensfleisch zum Gutenberg, a goldsmith born into a Patrician family in Mainz in the 1390s, was the main originator and innovator of this 'invention'.⁶⁸ There are as yet unresolved questions about his role in this development and the actual techniques he put into place, but the basic parameters of printing: punch, matrix,⁶⁹ hand mould, hand press seem have been established certainly by the time of the first dated Gutenberg publication, the *Catholicon* of 1460. In his introduction, Gutenberg mentions that it was printed and accomplished 'without the use of reed, stylus or pen, but by the wondrous agreement, proportion and harmony of punches and types'.⁷⁰ Paper was already available cheaply by that period and the relevant technologies such as those used by goldsmiths, in wine presses were complemented by what was the crucial invention of the adjustable hand mould. Talbot Baines Reed argued 'we find in the mould not only the culminating achievement of the inventor, but also the key to the distinction between the two school of early typography: xylography and the use of metal types'.⁷¹ Yet it is mainly true that 'print was itself a veritable cluster or galaxy of previously achieved technologies'.⁷²

Thus the salient stages in the invention of printing can be summarised as follows:

- Development of the requisite contributing technologies such as paper making, wine presses, metallurgy, engraving and punch cutting.
- Input from other existing printing technologies;
- Establishment of a potential market for the product;
- A period of experimentation with alternate solutions;
- Resolution of the main technological problems such as the adjustable mould, brass matrix and composition equipment.

⁶⁸ S. H. Steinberg, *Five hundred years of printing* (Harmondsworth, Middx.: Penguin Books, 1955), pp. 22-29. See also Albert Kapr and Douglas Martin, *Johann Gutenberg: the man and his invention* (Aldershot ; Brookfield, Vt.: Scolar Press, 1996) and John Man, *The Gutenberg revolution: the story of a genius and an invention that changed the world* (London: Review, 2002)

⁶⁹ The reversed image of the punch struck into a small copper bar. See glossary for definition.

⁷⁰ Steinberg, *Five hundred years of printing*, p. 23. This comment is very similar to that expressed by Rabbi Joseph ben Asher's in the colophon to one of first dated Hebrew editions, the *Arba'ah Turim* of 1475, in which he writes 'I am the art that is the crown of all the arts. I myself am hidden, but in me all secrets are revealed. Without pens my script is clear to all; without scribes do I create books. In a a moment I am dipped in ink. Without rulers, yet my script is evenly formed'. From Zinberg, *A History of Jewish Literature*, cited by Lloyd Jones, *The Discovery of Hebrew in Tudor England: a third Language*, p. 248

⁷¹ Talbot Baines Reed and A. F. Johnson, *History of the old English Letter Foundries* (London: Faber, 1952), p. 7

⁷² Marshall McLuhan, *The Gutenberg Galaxy : The Making of Typographic Man* (London Routledge & Kegan Paul, 1962), p. 151

There were five basic stages involved in the new craft: first cutting of the type punches and striking the matrices, second casting the type, third composition of the text, fourth printing of the text and fifth finishing of the printed item (i.e. folding, gathering and binding) if relevant. The first stage is what concerns us in this thesis and 'demanded a degree of skill in the handling of tools and experience in the working of metal rarely found in any man who undertook to learn the art of printing. They were never regarded as proper branches of the printer's trade, but were from the beginning set aside as kinds of work by the goldsmith only'.⁷³

This situation had changed by the sixteenth century, which may be viewed as a kind of golden age for punch cutting and whose typefaces are still used in those revivals issued in the twentieth century by the Monotype Corporation under the guidance of Stanley Morison.⁷⁴

The process of cutting (i.e. engraving) a punch and producing a matrix is indeed not a simple one, and there are several historical descriptions to mention. Plantin's *Dialogues françois pour les ieunes enfans*, issued in 1567, contains a very cursory description of the process, but Harry Carter commented that 'its shows that the tools, and therefore the methods, in use by the middle of sixteenth century were those remembered by older men in the trade today'.⁷⁵ There are no known early engravings of a punch cutter at work, however an wood engraving of a type caster does exist in the 1568 edition of Hans Sachs' *Eygentliche Beschreibung aller Stände auff Erden*. The mould is quite unlike anything that has survived today and Harry Carter wondered whether this depiction was at all reliable.⁷⁶

⁷³ Theodore Low DeVinne, *The Invention of Printing. A collection of facts and opinions descriptive of early prints and playing cards, the block-books of the fifteenth century, the legend of Lourens Janszoon Coster ... and the work of John Gutenberg and his associates. Illustrated with fac-similes of early types and wood-cuts* (New York: Francis Hart & Co., 1876), p. 514

⁷⁴ Stanley Morison and Ernest Crutchley, *A tally of types* (Cambridge: Cambridge University Press, 1973), pp. 32-39

⁷⁵ Harry Carter, *A view of early typography up to about 1600, (Lyell lectures, 1968)* (Oxford: Clarendon Press, 1969), pp. 5-7

⁷⁶ Hans Sachs and Jost Amman, *Eygentliche Beschreibung aller Stände auff Erden, hoher vnd nidriger, geistlicher vnd weltlicher, aller Künsten, Handwercken vnd Händeln &c. vom grösten biss zum kleinsten, auch von jrem Vrsprung, Erfindung vnd gebreuchen von dem weitberümpften Hans Sachsen ganz fleissig beschrieben vnd in Teutsche Reimen gefasset, sehr nutzbarlich vnd lustig zu lesen, vnd auch mit kunstreichen figuren, deren gleichen zuvor niemands gesehen ... allen Künstlern ... zu sonderlichem Dienst in Druck verfertigt* (Gedruckt zu Franckfurt am Mayn: bey Georg Raben, in Verlegung Sigmund Feyerabents, 1568). See also Carter, *A view of early typography up to about 1600*, pp. 17-18



Fig. 1.1: Wood engraving of a type caster (Der Schriftgeisser) From Hans Sachs and Jost Amman, *Eygentliche Beschreibung aller Stände auff Erden*, Frankfurt am Main, 1568.

Joseph Moxon's *Mechanick Exercises on the Whole of Printing* (1683) is the first detailed description in English, in which he claims that 'letter-cutting is a Handy-Work hitherto kept so conceal'd amongst the Artificers of it, that I cannot learn any one hath taught it to another; But every one that has used it, Learnt it of his own Genuine Inclination'. This may have been true in the case of Moxon, but not true for Guillaume I Le Bé, nor for other well known punch cutters, such as Claude Garamont, Nicholas Kis or Jacques I de Sanlecque. They were taught by punchcutters who were masters of the trade. Moxon does describe the letter cutter's tools as used in the late seventeenth century, the use of counter punches, the making of mould, striking the matrices, justifying the matrices, and the processes involved in casting type.⁷⁷

⁷⁷ Joseph Moxon, Harry Carter, and Herbert Davis, *Mechanick Exercises on the Whole Art of Printing* (London: Oxford University Press, 1962), pp. 87, 87-133, 134-190, 375-377

Finally there is the *Manuel Typographique* of Simon-Pierre Fournier (Fournier le Jeune) of 1764, which is devoted almost entirely to punchcutting. Fournier maintains that ‘a man cannot be a good punchcutter without being a typographer, that is to say, he must know every detail of the operations involved in typefounding and printing, that he may work with an eye to them’. Fournier argues that ‘the punchcutter should anticipate every step in the casting and impression of letters’, and cites Guillaume Le Bé as an example of such punch cutters, ‘to whom printing is indebted for the whole of its progress’ and as a ‘master of this art, which they have carried in France to the pitch of perfection which neighbouring peoples have never attained’. This sounds somewhat like patriotic hyperbole, and it is not obvious that punchcutter always exercised such control over the end result of their products.⁷⁸

A more recent discussion of punchcutting described the following specific steps involved in producing a punch:⁷⁹

- Preparing the steel bar for engraving
- Preparing and sharpening the tools
- Freehand drawing or making and transferring a smoke proof
- Roughing with the file
- Shaping with the file using successive markings
- Checking the outside dimensions with the gauges
- Digging out the counter with the graver
- Pricking (piquage) the slope of the face
- Levelling the floor of the counter
- Advance with the graver towards the final shape by means of successive markings after the examinations of smoke proofs
- Cutting the slopes
- Checking internal dimensions with the gauge
- Making smoke proofs
- Retouching, making markings with gravers and files, final polishing
- Checking with gauges and smoke proofs
- Hardening, cleaning and tempering

These procedures can also be seen in several short videos produced by the American punchcutter, typesetter and historian Stan Nelson, one of the few practitioners of this art still able to replicate the processes used in the sixteenth century.⁸⁰

⁷⁸ Pierre Simon Fournier and Harry Carter, *Fournier on Typefounding*. ed. by Harry Carter (London: Soncino Press, 1930), pp. 20-22

⁷⁹ Christian Paput, *La lettre/La Gravure du Poinçon typographique* (Tallard: TVSO Editions, 1998), pp. 26-27

⁸⁰ Stan Nelson, '1-Punchcutting at the Atelier Press & Letterfoundry' (2009) <<http://www.youtube.com/watch?v=eExllUeGtvc>> 9 April 2014] and Stan Nelson, '2-Tempering Punches and Striking Matrices' (2009) <<http://www.youtube.com/watch?v=QyiCPzERIGA>> 9 April 2014]



Fig. 1.2: Inscribing the character on the head of the punch – A clip from Stan Nelson video Punchcutting at the Atelier Press & Letterfoundry

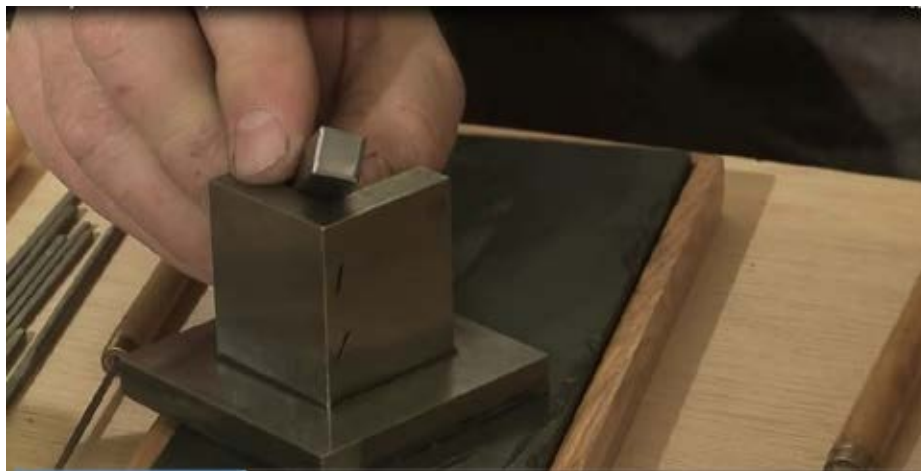

Fig. 1.3: Leveling the head of the punch – A clip from Stan Nelson video Punchcutting at the Atelier Press & Letterfoundry

The tools used by a punchcutter such as Le Bé would not have been numerous and he certainly would have been able to carry them with him on his travels. They would have included, at the very minimum, various types of files, various face gauges for size and height, magnifying glasses, steel pointed tools for inscribing the image on a punch, oilstones and sharpeners, a small anvil or stake, various types of engraving tools (Moxon calls them gravers and sculpters), pincers or some type of vice for holding the punch during the engraving, a small lamp for producing smoke proofs, hammers, brushes and possibly a supply of unfinished punches.

The tools shown by Harry Carter in Appendix K include some more sophisticated equipment as used in Oxford University Press in the last century, but the essential tools are the same as would have been used by Le Bé. These are best shown in the two plates from Fournier's *Manuel Typographique*. The first plate (III) shows various face gauges, set squares, adjustable gauges, a stake with a square hollow in middle to hold the steel while it is counter punched, a magnifying glass, and a guide

which is used marking plain chant or music punches. The second plate (IV) shows various files, a steel point for drawing, liners used as a straight edge in aligning letters, an oilstone bedded in wood, a stepped punch with and without the accent, the accent, a counterpunch, brushes, pincers, and light hammer.⁸¹

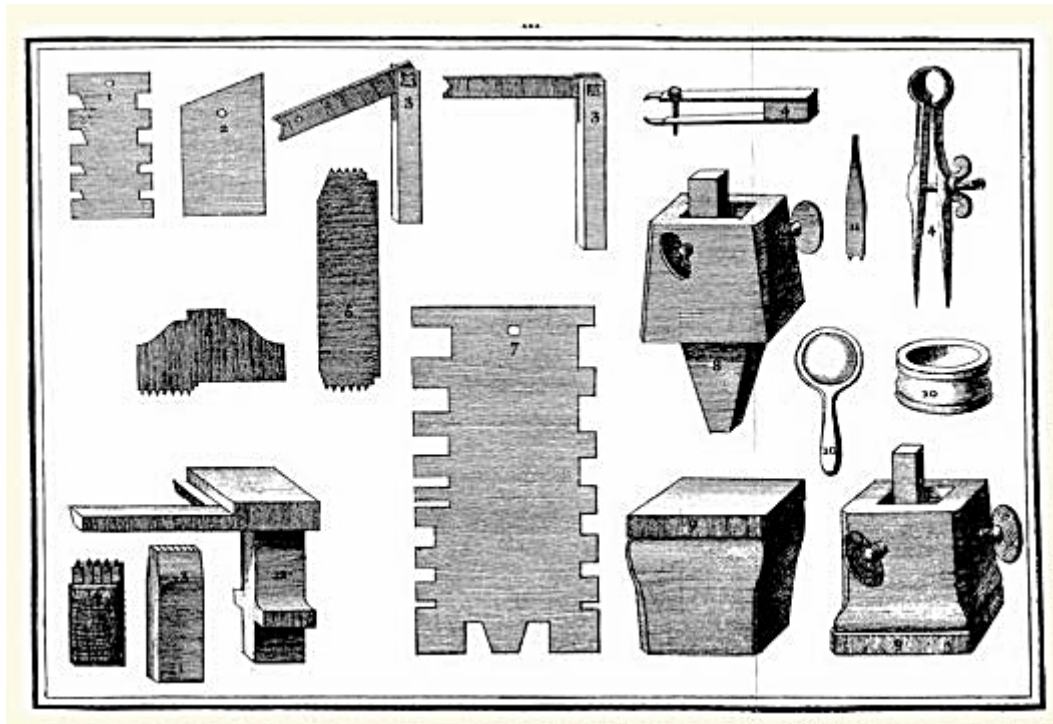

Fig. 1.4: A Punchcutter's tools of the seventeenth century. Plate III from Fournier's *Manuel Typographique*

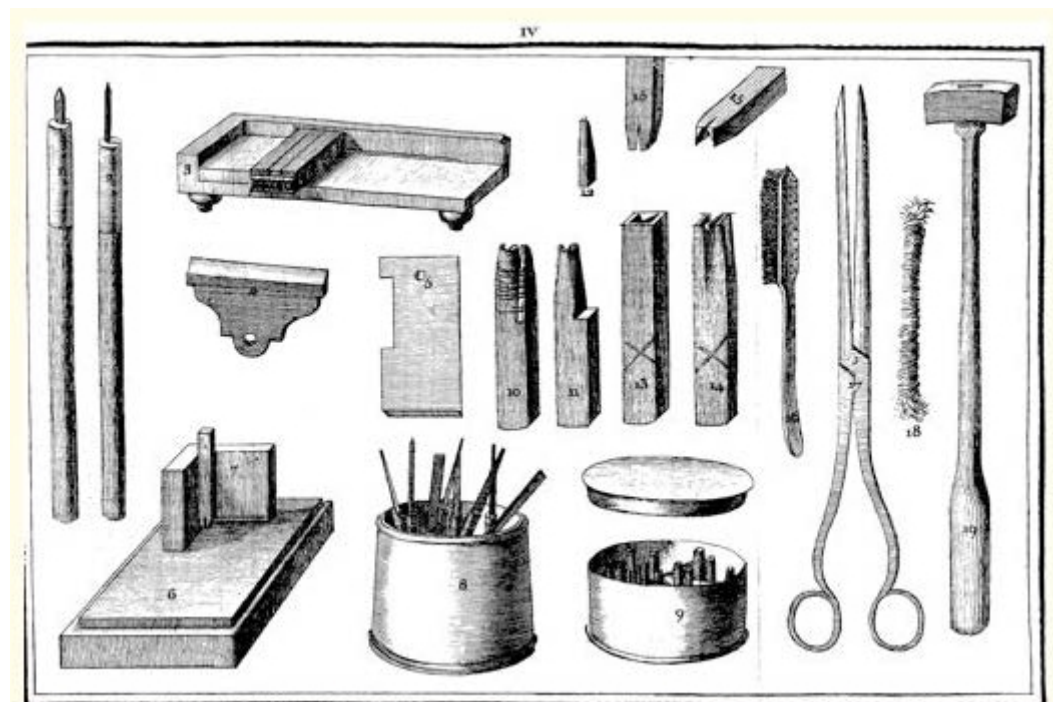

Fig. 1.5: A Punchcutter's tools of the seventeenth century. Plate IV from Fournier's *Manuel Typographique*

⁸¹ Fournier and Carter, *Fournier on Typefounding*, pp. 301-303

There are some records, mostly in the MPM archives, which gives details of the actual economics involved in punch cutting. The punchcutter Robert Granjon, for example, reckoned his prices on the basis 'of the punch plus one matrix struck with it'. In July 1565 'he agreed to supply Plantin with a garamond italic and a mediane italic at 2 florins for each punch with one justified matrix'. Later in 1569 he supplied 100 punches for a Syriac fount at a cost of 2 florins and 5 stuyvers per punch with one justified matrix.⁸² In 1565 Granjon supplied a parangon Greek at 1 florin per punch. The punchcutter Hendrik van den Kerre was also frequently used by Plantin and in 1570 he supplied 68 punches at 1 florin per punch. It thus seems that the price per punch paid by Plantin in the third quarter of the sixteenth century – with or without the justified matrix – was between 1 and 2 florins. The prices Plantin paid to Le Bé for Hb12 (S) in 1562 – 5 escu to 50 sous – appear to be much lower than normal prices, and the same for the material Plantin bought at the auction of Garamont's estate in 1561, but these prices may be a reflection of the general perilous state of the business during the French Wars of Religions.

One can gain a sense of the relative value of these sums by comparing them to the wages paid to compositors and printers in the *Officina Plantiniana* during the same period. The wages for a compositors varied between 68 fl. 13 st. to as much as 284 fl. 13 st. during the period 1564 to 1587. For pressman the variation was between 76 fl. 3 st to 276 fl. Thus the financial rewards for a punchcutter, even if he were able to produce several complete founts per annum, were not excessive.⁸³

The relative output of the prominent punchcutters of the sixteenth century is discussed in more detail in Chapter 5.⁸⁴

The analysis of the typefaces in the two documents

When beginning the initial analysis of the types, the most sensible approach seemed to assign a specific number to each occurrence of every type in the two documents. The exact number of distinct types and the amount of duplication between the two documents was not certain at that point, and the initial analysis showed about 110 occurrences of all types in both documents. This allowed an identification of the location per document and folio according to the folio numbering assigned by the BnF and used by Omont, Vervliet and Carter when they referred to certain types.⁸⁵ The numbering system chosen included the document number, the folio number and a specific numeric code, for example 4528/1/1.

⁸² The Flemish Guilder or Florin was equal to 20 stuyers (or stuyvers) or patars. See Leon Voet, *The Golden Compasses. A history and evaluation of the printing and publishing activities of the Officina Plantiniana at Antwerp, etc. vol. 2. The management of a printing and publishing house in Renaissance and Baroque* (Amsterdam: Vangendt & Co, 1972), pp. 81-91, 440-453

⁸³ *Ibid.*, pp. 336-338

⁸⁴ See page 364.

⁸⁵ See for example Harry Carter, 'A Message from Plantin to Guillaume Le Bé', *De Gulden Passer*, 36 (1958)

Following the completion of the initial analysis and part of the primary research, the types were then renumbered, so that each type style – loosely a fount of type – was allocated a unique number, and identification code as to language (Heb for example – and style – for example SS = square Sephardic or RS = Rashi script or Gloss). This followed the model used by Vervliet in his *Conspectus*, but without the size, as it seemed preferable not to link the size to the code, given the difficulty in arriving at an absolute size determination. Vervliet also used an equivalent old English body name in his descriptions, which is perhaps logical for Roman and Italic types, but less certain for Hebrews and more difficult to use given the names and descriptions used by Le Bé in his annotations. A final renumbering was found to be necessary to correct mistaken attributions or numbering which became apparent after the completion of the first draft of Chapter 3. This final numbering system used a combination of a language code (Hb for Hebrew, Rm for Roman, It for Italic, Ms for Music and Gk for Greek, plus a unique identifying number, and a code to identify the style – S for Sephardic, R for Rashi and A for Ashkenazic).

It needs to be noted that the chronological order of the appearance of the specimens NAF 4528 was followed in the actual numbering, and *not* the order in which they appeared in the documents. The appearing order can be seen in the facsimile in Appendix C. However the appearing order in Rés X 1665 was followed as closely as possible, given the lack of dates in most of the specimens.

If we accept the thesis that each fount was cut for a particular size of hand mould, as was put forward by Carter and Burnhill, then it is the mould size which determined the body size – and hence name – of the type.⁸⁶ The moulds were adjustable horizontally as can be seen from the surviving examples in the Plantin Moretus Museum, but this was in order to accept different matrix widths from the same fount.⁸⁷ As is clear from a comparative chart of the old English and old French body names sizes for the sixteenth century are approximate and can vary quite widely.⁸⁸ It thus seemed best to stick as closely as possible with the names that Le Bé had assigned in his annotations and not attempt a translation into a different typographic nomenclature system. What complicates the matter further is that it is not known if leading – what is known now as interlinear spacing – was used during the Incunabula period or indeed in the sixteenth century.⁸⁹ The most accurate assumption is that types were set ‘solid’, but occasionally cast on a larger size mould

⁸⁶ Carter, *A view of early typography up to about 1600*, p. 8 and Peter Burnhill, *Type spaces: in-house norms in the typography of Aldus Manutius* (London: Hyphen Press, 2003), p. 11. See also DeVinne, *The Invention of Printing*, p. 518 ‘As the size of every body is determined by the mould in which it is cast, it would seem that there must have been a separate mould for every distinct body’.

⁸⁷ Mike Parker, ‘Early Typefounder’s Moulds in the Plantin-Moretus Museum’, *The Library*, s5-XXIX (1) (1974)

⁸⁸ Vervliet, *French Renaissance Printing Types: A Conspectus*, pp. 52-53. See Appendix B, page 393.

⁸⁹ The punchcutter Hendrik van der Keere described a technique called ‘packing’, which involved the insertion of body brasses in the mould to reduce or enlarge the type body, to allow him to use a different mould than the one intended for a specific size. See Vervliet and Carter, *Sixteenth-century printing types of the Low Countries*, p. 334

to take into account accents or diacriticals. There is evidence for this procedure for Hebrew casting in Fournier's *Manuel Typographique*, where he writes that 'having dressed a mould for casting the letter on a body rather smaller than the face ... they prepared a second which had a body equal to that of the letter added to that of the points, so that if one were pica and the other nonpareil, their second mould was great primer, which is the size of a nonpareil added to a pica. In these two moulds, one pica and the other great primer, they cast all the letters of the alphabet, making the characters range at the feet'.⁹⁰ There is also evidence for this procedure in some of the annotations by Guillaume II Le Bé to the 1599 specimens now in the Plantin Moretus Museum in Antwerp, where it is noted for one example 'texte hébreu a fondre avec les pointz sur le Saint Augustin' – for Hb18 (S) on 4528 f. 2v.

Unless there are examples of risen spacing in a printed text, there is little likelihood that this point can be finally established. There are three possible risen spaces in Rés X 1665 (folios 1v, 6r and 10v), but they do not provide enough information to make any clear measurements. The late Peter Burnhill attempted an analysis of printed text in four Aldus Manutius editions and came to the conclusion that 'the line-increments (mould size) determined for the text provided the punchcutter with his scale of values for gauging the grosser dimensional attributes and ratios of a projected set of characters'.⁹¹ This hypothesis does appear to hold true for some Hebrew examples examined for this thesis, by using a simple method of measuring the baselines of a sufficient number of lines of text and then measuring across the text measure. The resulting text measure generally came out as an even number of lines, thus showing that the em – the nearest square measure – of the fount used was in effect the measurement used by most compositors of the period.⁹² Pointed Hebrew setting could well have been set using related – i.e. proportional – units of the em in order to allow the type to fit and lock up securely in a forme. Recent work by Scott-Martin Kosofsky supports this hypothesis.⁹³

There are several examples of risen type from the Incunabula period, most in Latin and one other Hebrew. They give some idea of what type would have looked like in that period, its relative size and the lack of certain features (such as the feet), which may have developed only later. There is no obvious nick in the Hebrew example, and the bottom appears to be rounded at least on one side. The beard is quite vertical.⁹⁴

⁹⁰ Fournier and Carter, *Fournier on Typefounding*, p. 152

⁹¹ Burnhill, *Type spaces: in-house norms in the typography of Aldus Manutius*, p. 11

⁹² I am indebted to Dr. Claire Bolton for pointing out this method to me. For a more detailed discussion of this subject see Claire Bolton, 'The 15th-Century Printing Practices of Johann Zainer, Ulm, 1473-1478', University of Reading, 2008)

⁹³ See page 271 of this thesis.

⁹⁴ See DeVinne, *The Invention of Printing*, p. 520 and Aron Freimann and Moses Marx, *Thesaurus typographiae Hebraicae saeculi XV = Hebrew printing during the fifteenth century (Ha-Qtsar li-melekhet ha-defus ha-ivri ha-rishonah ad shenat r"o)* (Jerusalem: The Universitas Booksellers, 1969), pp. (Plate 10,12). See also James Mosley, 'Fallen and threaded types'(2007) <http://typefoundry.blogspot.co.uk/2007_06_01_archive.html> [Accessed 10 April 2017] and Neil

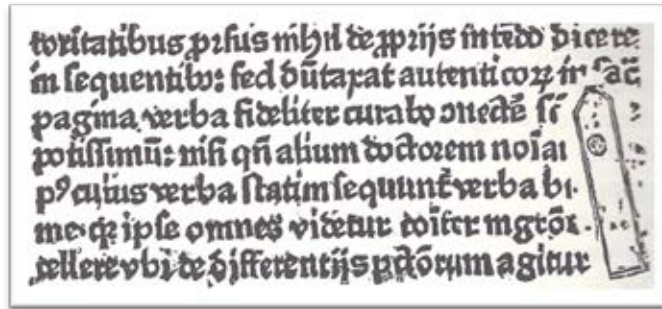

Fig. 1.6: Example of risen type from Cologne edition 1476

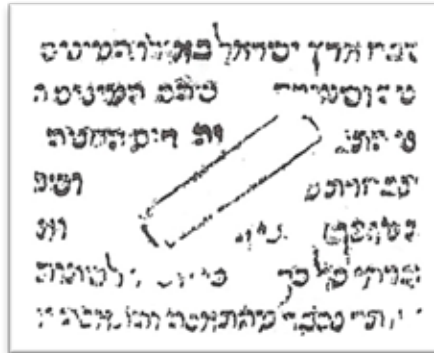

Fig. 1.7: Example of a risen type from *Perush HaTorah*, ca. 1480 Mantova (From Freimann, *Thesaurus typographiae Hebraicae saeculi XV*, A10,2)

The parts of a Hebrew type character are identical to any other typographic character, and are as follows: ⁹⁵

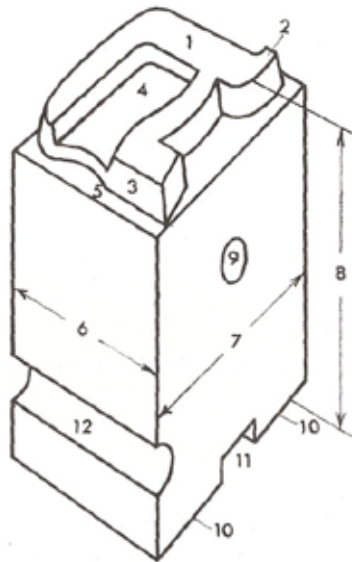

Fig. 1.8: The parts of a Hebrew typical type character

Harris, 'A mysterious UFO in the Venetian 'Dama Rovenza' [c. 1482]', *Gutenberg-Jahrbuch*, 78 (2003)

⁹⁵ G. Silberberg, *Principles of Printing (Torat HaDefus)* (Tel Aviv: The Union of Printing Workers in Israel, 1968), p. 30. See also John Ryder, *Printing for Pleasure* (London: The Bodley Head, 1976), p. 33

1. The eye (עין or ayin): The printing portion of the type which receives the ink and is transferred to paper. This is also called the face or 'oeuil' in French.
2. The termination stroke (קו סיום or Kav-si'um). This equates roughly to the serif in Roman and italic typefaces. Gaskell calls this a 'termination' when referring to capitals letters and 'serif' when referring to lower case.
3. Head (ראש or Rosh): This is known as the beard or bevel and is the 'steeply sloping surface between the printing surface and shoulder'.
4. Counter (תיתרה or Titorah): The counter is the 'area enclosed by a bowl' which is the 'curved stroke enclosing an area'.
5. The shoulder (כתף or Katef): The 'flat non-printing surface of the type'. It also can mean a 'curved stroke springing from a stem' (Gaskell) and Silverberg notes that this relates to descenders (the final letters ך / ן / ף / ץ) and the ascender of the lamed (ל).
6. Width (רוחב or Rohav): the 'set' of the character which varies from character to character.
7. The body or point size (מידה or Midah): This equates to the body size of the typeface. This is also called a shank.
8. Height to paper (גובה or Govah): The standard for Anglo-American is .918" Or 23.32 mm and Didot is 23.686 mm. In the Incunabula period and the sixteenth century there were no fixed norms and type heights could differ between individual printers and typographic 'cultures'. The mould sizes more than often determined the body size.
9. The pin mark (סימן מסמר ההוצאה or Siman Mesmer HaHotza'ah): Also known as a 'drag' and may indicate the foundry name or type size.
10. Feet (רגליים or Reglaim): The base of the type which is formed after the 'tang' is broken off from the newly cast type and the type finished to give it a uniform height.
11. Heel-nick or groove (חריק or Cherik): The notch left between the feet after the tang is broken off and the feet levelled. Moxon describes this under the category 'of the dressing of letters'.⁹⁶
12. The Nick (חריץ or Haritz): The square or rounded slot formed during the casting which indicates the base of the character to the compositor and an aid in distinguishing between similar characters, for example the 'n' and the 'u' in a Roman fount.

These various parts of the typeface are important as they each represent a particular part of the process of punch cutting, of casting type, of finishing the type or of

⁹⁶ Moxon, Carter, and Davis, *Mechanick Exercises*, pp. 184-188. James Mosley maintains that these hole most probably indicated the use of wire to thread the lines of type together. See Mosley, 'Fallen and threaded types'

printing type. As an example, the beard needed to be deep enough to prevent the non-printing parts of the type from inking and hence leaving a sign on the printed page. This was also the reason that the depth of the strike on the matrix was so important to produce a clean image of the actual character. As another example, the nick was vital to show the compositor which side was up. An early impression of raised piece of type from a Cologne edition of 1476, pulled up by error during inking and impressed into the paper, shows a small hole on the side of the piece of type, may have been cast there to serve this purpose. In most moulds that have survived the nick is produced by a small piece of wire embedded in the mould.⁹⁷ The feet are produced during the finishing process after the type has been cast, and the 'shank' or excess material broken off. Specialist tools such as a dressing block, dressing hook and dressing knife were developed to provide an even flat surface for the base of the type. Similar tools were also used to remove excess type metal from letters with long descenders or ascenders which needed to be kerned. This was vital for the composition of pointed Hebrew.⁹⁸

Gaskell proposed a system of nomenclature for the letter forms of Roman type, but this has not been attempted for Hebrew type.⁹⁹ The closest to such a description was used in palaeographic studies such as Bernheimer and Birnbaum.¹⁰⁰ Gaskell's nomenclature is generally relevant for Hebrew types, with certain exceptions such as the term 'serif' which does not accurately apply to Hebrew characters, and the terms 'majuscules' and 'miniscules', which do not exist in the Hebrew script.¹⁰¹

The criteria used for description of the types

One of the few scholarly studies to attempt a full description of a printer of Hebrew editions is that undertaken by Herbert Zafren on the German Jewish printer Shabtai Meshorer Bass (or Shabbethai ben Joseph Bass) who was active in the town of Dyhernfurth (now Brzeg Dolny in Poland) in lower Silesia from 1689 to about 1714.¹⁰² Zafren took a small sample of 29 editions available to him and used the following categories for his analysis.¹⁰³

1. A bibliography of the known printed works from his press – the artefacts

⁹⁷ DeVinne, *The Invention of Printing*, pp. 519-520. The risen type is taken from Madden,

⁹⁸ Moxon, Carter, and Davis, *Mechanick Exercises*, pp. 179-190

⁹⁹ Philip Gaskell, 'A nomenclature for the Letter-forms of Roman Type', *The Library: The Transactions of the Bibliographical Society*, XXIX (1974). He proposes a total of 74 terms and 18 'modifiers'.

¹⁰⁰ See Carlo Bernheimer, *Paleografia ebraica* (Firenze: L.S. Olschki, 1924) and Solomon A. Birnbaum, *The Hebrew scripts* (London: Palaeographia, 1971)

¹⁰¹ See Stephen Lubell, 'The Hebrew Typeface Designs of Zvi Narkis', *Gutenberg Jahrbuch* (2003), p. 219

¹⁰² Herbert C. Zafren, 'Dyhernfurth and Shabtai Bass: A typographic Profile', in *Studies in Jewish bibliography, history and literature in honor of I. Edward Kiev*, ed. by I. Edward Kiev and C. Berlin ([S.l.]: Ktav, 1971)

¹⁰³ *Ibid.*, p. 544

2. A careful list of those works which were examined by the investigator so that the work may be checked and expanded by others
3. A bibliography of the secondary literature on the place and printer
4. A record of all title page cuts (i.e. blocks)
5. A record of the type faces and sizes
6. A record of the metal ornaments (flowers)
7. A record or transcription of the ornamental and illustrative cuts (i.e. blocks)
8. A description or other distinguishing features if any (i.e. signatures, watermarks etc.)
9. A listing of special problems, with or without solutions

This is a useful list, and some of these elements will be discussed in this thesis. Zafren's comments on the measurement of the types are of interest. He writes:

Measurement for type – as indeed of ornaments and woodcuts as well – is a difficult matter. Although letters may come from the same mould and therefore be exactly the same size, they may appear to be of different sizes or actually measure as different sizes, several hundred years after printing. Appearance is affected by the measure and amount of leading, and actual size is determined by such factors as the condition of the type, the expansion, contraction, or wrinkling of the paper and the amount of inking or bleeding

Ordinarily one would measure ten or twenty lines of unleaded type and calculate an average to determine the size of the type. The Hebrew faces that we are concerned with offer problems of ascenders, descenders, vocalization, and various leading, among other things, *that make normal measurement difficult*. (My italics) Furthermore, such measurement yields the body size of the type, without revealing the size of the face. Different sizes can be on the same body size. At this stage, it seemed important to me to recognise differences in face sizes (because there are no face names beyond the generic) and I preferred to risk the problems of measuring the so-called x-height of letters (excluding those that have ascenders and descenders). ... The measurements cannot be absolute because of the variables mentioned above, but one size can be relatively differentiated from other. One further point: when an elongated ך is referred to, it is always the final letter (ך).¹⁰⁴

This is fair comment on the problems of measuring Hebrew types and Rashi types in particular. Zafren refers to pointed as vocalized and mentions specific line of texts which he has measured. He also mentions when dilated or extended letters

¹⁰⁴ *Ibid.*, p. 548

(sometimes known as *literae dilatabiles* in the literature) are used and the date.¹⁰⁵ In the course of the analysis of the Le Bé documents, other criteria began to appear for the description of the types. Some of these were:

- Measurement of square characters where it is relatively easy to establish the appearing size of the typeface, such as the mem (מ), the final mem (ם), the bet (ב), the nun (נ)
- Measurement of the height of lamed including ascender
- Description of the type of termination stroke (serif) on the lamed
- Description of the junction of the base and downward strokes of the gimmel (ג). This is often the main distinguishing factor between a gimmel and a nun
- Description of the type of junctions of the strokes on the shin (ש)
- Description of the type of junction of the middle stroke on the tet (ט)
- Description of the *literae dilatabiles* where available
- Description of variants of standard weight where they exist and measure the differences of set between variants
- Description of junctions where strokes meet: smooth, angular or pointed
- Description of any additional symbols used, such as *signes de renvois*¹⁰⁶
- Description of any obvious kerning which would indicate combined use of letter and vowel punches¹⁰⁷
- Description of any obvious characteristics of the vowel points where they are available and their placement/proximity to the letters
- Description of any obvious characteristics of the cantillation points where they are available and their placement/proximity to the letters¹⁰⁸

Some of these points, where relevant, will be described in the discussion of recognition factors for each fount.

Vervliet in his *Conspectus* listed the following seven descriptives for each typeface reviewed:¹⁰⁹

¹⁰⁵ Wilhelm Gesenius, E. Kautzsch, and A. E. Cowley, *Gesenius' Hebrew grammar* (Oxford: Clarendon Press, 1910), p. 27

¹⁰⁶ See page 47 of this thesis.

¹⁰⁷ Kerns or kerned letters are 'such as have part of their face hanging over one side or both sides of their shanks'. William Savage, *A Dictionary of the Art of Printing* (London: Longman, Brown, Green and Longmans, 1841), p. 429

¹⁰⁸ These cantillation marks, known in Hebrew as 'Ta'amim', have been defined as a system of strokes, dots and other signs ... which determined the grouping of the words in phrase and verses according to the traditional sense, and thus made possible the reading, and even the singing of the (Massoretic) text with proper meaning'. See Bernard Casper, *An introduction to Jewish Bible Commentary* (New York and London: Thomas Yoselof, 1960), pp. 40-41

¹⁰⁹ Vervliet, *French Renaissance Printing Types: A Conspectus*, p. 51

- The name of the typeface
- Its measurements
- Its letter family and letter group
- The punchcutter (and or/eponym)
- The first occurrence
- The (first) type specimens and artefacts such as punches or matrices that have been preserved
- The most recent literature and notes

It is the intention in this thesis to use the same basic criteria, plus visual samples of the specimens, alphabets and examples from relevant editions, with a greatly expanded discussion section for each typeface. A few qualifications as to the way this will differ from Vervliet's system are in order.

As previously noted, Vervliet uses the traditional Old English size names, the Proctor-Haebler 20 line measurement, the x-height and the capital height for Romans. Vervliet notes that the 20 line measurement is used for unleded setting, and maintains that the unleded setting measure is essential, yet this is not always straightforward to determine. He also notes that the 20 line measure is in fact a measure for the mould and not the face and that an unevenly designed sort can be a 'weak indicator of the exact size of Hebrew or Arabic type'.¹¹⁰ This measurement is normally shown as 20:89, or 89 mm depth for 20 lines.

Vervliet classes the types firstly according to letter family (Roman, Italic, Hebrew, Greek, Arabic and Phonetic) and then by letter group (Romans divided into Jenson, Bembo and Old face Romans, Italics divided into Aldine or Old face; Greeks divided as Graeco-Roman, Aldine or Old Face, Hebrews divided into Square Sephardic, Square Ashkenazic or Rabbinical. Regarding the Hebrew types, Vervliet writes: 'The major terms used here to clarify and describe Hebrew letter designs pertain to scripts rather than to letter groups. In sixteenth-century France the following letter groups appear: Square Sephardic (a south European formal script), Square Ashkenazi (the German formal Hebrew) and Rabbinical (a Sephardic cursive script used for commentaries). The Ashkenazic types used in France seem to have been imported, and Yiddish, as a script type mainly for a vernacular readership in Germany and Italy, was used in Strasburg in 1592, but not within France within its sixteenth-century borders'.¹¹¹ In the Le Bé documents there is only one folio with Ashkenazic scribal hands and types, and no occurrences at all of the Yiddish founts.

Finally, Vervliet restricts himself in his *Conspectus* to 'type designs conceived or perfected' within the geographical borders of sixteenth-century France.¹¹² The two

¹¹⁰ *Ibid.*, p. 54

¹¹¹ *Ibid.*, p. 56

¹¹² *Ibid.*, p. 15

documents in the BnF contain specimens from France, Italy and the German-speaking lands and thus cover a much wider geographical spread.

The criteria for the selection of Hebrew editions to be examined

An important part of the doctoral researches involved an examination of as broad a sample as possible of Hebrew editions printed in the sixteenth century. The reason for this examination was to plot the spread of the Hebrew types represented in the two Le Bé documents.

One major criterion in the selection of archives or libraries was to find collections with well-catalogued and representative holdings, which would be easily accessible and which would allow digital scans of relevant documents. The first choice was the Valmadonna Trust Library in London, which holds one of the largest collections of fifteenth and sixteenth-century Hebraica in the world. Sadly this option disappeared early on in the research, as the collections were moved to New York for eventual sale, however the Custodian (Mr. Jack Lunzer) allowed me to make use of the very extensive secondary material still remaining in London. I also used the very rich holdings of the Leo Baeck College Library in London, which holds many items from the London Beit Din. In the end, two collections became obvious choices, due to their representative holdings, accessibility and high level of cataloguing: the British Library and University College London/Special Collections.

The following list summarises the Hebraica holdings in the periods and printers of interest in the British Library and University College Library Special Collections.

<i>City or Printer</i>	<i>Period</i>	<i>Number of entries in the British Library</i>	<i>Number of entries in UCL Special Collections</i>
All cities and printers	1450 to 1500	100 ¹¹³	6
All cities and printers	1500-1600	1165	146
All cities and printers	1600-1700	1239	111
Adelkind/Venice			3
Amsterdam	1600-1700	191	2
Amsterdam	1500-1600	0	16
Augsburg	1500-1700	9	
Basle	1500-1600	10	
Bologna	1500-1700	2	
Bomberg/Venice	1500-1550	28	24
Bragadin/Venice	1540-1600	6	3
Cavalli/Venice			8
Conti/Cremona			5
Cracow	1500-1600	27	
Di Gara/Venice	1540-1600	21	21
Estienne/Paris			6
Ferrara	1500-1700	20	
Firenze	1500-1700	0	
Frankfurt am Main and Frankfurt an der Oder	1500-1700	27	
Giustiniani/Venice	1540-1600	9	5
Mantua	1500-1700	18	

¹¹³ A. K. Offenbergh and British Library, *Catalogue of books printed in the XVth century now in the British Library: BMC part XIII, Hebraica* ('t Goy-Houten: Hes & de Graaf, 2004)

City or Printer	Period	Number of entries in the British Library	Number of entries in UCL Special Collections
Padua	1500-1700	0	
Paris	1500-1600	4	3
Paris	1600-1700	1	
Prostitz/Cracow			6
Riva di Trento	1500-1700	20	
Rome	1500-1700	3	
Soncino/Italy	1490-1550	40	4
Venice	1500-1600	183	17
Venice	1600-1700	116	5
Waldkirch/Basle			2
Wittenberg	1500-1600	5	

Fig. 1.9: Table of Hebraica holdings in the British Library and UCL Special Collections

As a comparative figure, Vinograd's major survey of Hebrew editions lists over 1500 purely Hebrew editions printed in Italy in the sixteenth century, with nearly two thirds of them printed in Venice.¹¹⁴ Schwarzfuchs, who included all editions containing Hebrew text in the sixteenth century, listed 439 editions for Paris alone, and 129 for Geneva during the same period.¹¹⁵

Thus the plan was to make as representative sample as possible given the time and archives available. Certain types of books, such as Machzorim (prayer books), Bibles (Tanakh and the Pentateuch), the Mishnah, compilations of Jewish law – such as the *Mishneh Torah*, the *Talmud* and the *Shulhan Arukh* – tend to present a wider selection of Hebrew types, both text and display, and these are especially useful to examine. The work of Marvin J. Heller on sixteenth and seventeenth century Hebrew books has been particularly useful in identifying editions to view.¹¹⁶ The total number of Hebrew editions viewed is in excess of 200.¹¹⁷ No sample can be totally representative, as individual editions themselves vary and may lack relevant pages – such as the title page or colophon, but such a survey does give a good indication of what may be found and provides possible preliminary conclusions as to the distribution of Hebrew types during the sixteenth century and later.

The method used during the investigation of these editions involved recording all relevant data on a two-page standard documentation form and, in particular, the data for each separate Hebrew type used in that edition.¹¹⁸ These types were then compared to the Le Bé documents types, and definitive or tentative attributions made according to type, size, leading and key recognition factors. This data was then transferred from an intermediate database to a final listing by type number and date.

¹¹⁴ Yeshayahu Vinograd, *Otsar ha-sefer ha-Ivri: reshimat ha-sefarim she-nidpesu be-otiot Ivrit meshit ha-defus ha-Ivri bi-shenat 229 (1469) ad shenat 623 (1863)* (Yerushalayim: Ha-Makhon le-bibliyografyah memushshevet, 1995)

¹¹⁵ Schwarzfuchs and Coron, *Le livre hébreu à Paris au XVIe siècle*

¹¹⁶ Marvin J. Heller, *The sixteenth century Hebrew book: an abridged thesaurus* (Leiden: Brill, 2004) and Marvin J. Heller, *The seventeenth century Hebrew book: an abridged thesaurus* (Leiden and Biggleswade: Brill and Extenza Turpin, 2011)

¹¹⁷ See bibliography of primary sources starting on p.568.

¹¹⁸ See Appendix H, p.561.

Le Bé mentions several printers in his notes with whom he worked or to whom he sold matrices of his types. In Venice these printers were Marco Antonio Giustiniani, Meir di Parenzo and Carlo Querini. He does not mention specifically the printer/publisher Alvise Bragadin, but the attribution of several Le Bé types in Bragadin editions leads to the conclusion that he *did* have connections with him. In Paris Le Bé was a pupil or was apprenticed to Robert Estienne, and it is very likely that he contributed to some of the Hebrew types which appear in the Estienne editions of that period. Le Bé supplied Hebrew types to Christopher Plantin in Antwerp, many of which are to be found in the Plantin Moretus Archives. Another question to be explored is whether Le Bé had any contact with Daniel Bomberg or his successors. Finally, there is strong visual evidence that the Le Bé Hebrews were used by other Italian printers, and eventually found their way to printers outside Italy, for example to Konrad Waldkirch in Basle, and Aaron Prostitz in Cracow.

In addition to the British Library and UCL Special Collections, Hebrew editions were examined in the John Rylands Library in Manchester, Lambeth Palace Library in London, the BnF in Paris, and the Bibliothèque Mazarine in Paris, as well as in online digital databases such as the Jewish National University Library Digitised Book Repository, Google Books, Archive.org, VD16 and e-rara.ch.¹¹⁹

An additional related task in this thesis was to identify the sources of the texts in the specimens in the Le Bé documents. The most useful and comprehensive tool for this was the Bar Ilan Responsa Project, which offers 'a searchable database of the full text of the Bible and its principal commentaries, the *Babylonian Talmud* with the Rashi commentaries and Tosafot, the *Jerusalem Talmud*, the *Mishneh Torah* of Maimonides, 300 Rambam Commentaries, the *Shulchan Arukh* with commentaries, Midrashim, and hundreds of books of Responsa'.¹²⁰ In addition I received much direct assistance from Rabbi Alex Chapper of the Ilford Federation Synagogue in locating certain problematic texts.

The Hebrew alphabet and the varieties of Hebrew printing types

The subject of this doctoral research, Guillaume I Le Bé, produced some 20 Hebrew types following a certain model, that of the Sephardic script, and did not produce any types using the Ashkenazic model, the other dominant Hebrew scribal tradition that was represented in print. To understand the reasons behind this preference, it is useful to present a brief overview of development of Hebrew as a writing system and the different styles that developed over its long history.

The Hebrew alphabet as a writing system is descended from what is now called the proto-Sinaitic inscriptions. These inscriptions were first discovered by Sir William

¹¹⁹ VD16 = Bibliography of Books Printed in the German Speaking Countries of the Sixteenth Century
e-rara.ch = 16th century Swiss prints held by Swiss libraries available online

¹²⁰ Bar Ilan University, 'Global Jewish Database (the Responsa Project)', Bar Ilan University, (2011) <<http://www.biu.ac.il/jh/Responsa/>> accessed at Leo Baeck College Library and online at the Spertus Institute for Jewish Learning and Leadership.

Flinders Petrie (1853-1942) at Serabit el-Khadim in the Sinai Peninsula in 1904/05. Subsequent work by Gardiner, Grimme, Van den Branden, Winnett, Albright, Beit-Arié, Sass and Harris has confirmed Petrie's original idea that the inscriptions were alphabetic, but based on pictographic models.¹²¹ The epigrapher Joseph Naveh has categorised the Proto-Sinaitic inscriptions as part of the Proto-Canaanite script which has three main characteristics:

1. It was invented c. 1700 BC by Canaanites who had some knowledge of Egyptian writing.
2. It had initially 27 letters representing the consonantal system – a writing system mainly without vowels, but had been reduced to 22 by the thirteenth century BC.¹²²
3. The signs were pictographic and most had acrophonic values. These evolved into linear letters.

Some of these characteristics, namely a mainly consonantal alphabetic script, and the number of glyphs, have remained consistent in Hebrew throughout its development. It is necessary here to stress the distinction between the different types of Hebrew scripts. There is some confusion as to terminology here, as different sources and authorities have used different terms. Joseph Naveh uses the term 'Hebrew' to refer to the paleo-Hebrew script used before the First Temple period and before the adoption of the Aramaic script in the fifth century BC, whereas he uses the term 'Jewish' to refer to the script developed by the Jews from Aramaic writing, or what is also known as 'Assyrian Script' or 'Square Hebrew'.¹²³ In this thesis, the term 'Hebrew square script' refers solely to the Aramaic script adopted in the fifth century BC and does *not* refer to the earlier Palaeo-Hebrew script.. In matters relating to Hebrew typographic history, the letters used are only from this later model.

The proto Canaanite script separated into four main streams in its subsequent evolution: South Arabic, Archaic Greek, Aramaic and Hebrew.¹²⁴ There is a common ancestry between the Hebrew script and the branch which led to Greek and eventually Roman letterforms. Naveh writes that 'there is common consensus among scholars regarding the West Semitic origins of the Greek alphabet'.¹²⁵

This consensus is based on the names of the letters – Herodotus called them *phoinikeai grammata* or Phoenician letters,¹²⁶ the names of the letters of which have no meaning in Greek, but are clearly derived from the Semitic names, the similar

¹²¹ For more details on Proto-Sinaitic Inscriptions see 'Proto-Sinaitic Inscriptions' (<<http://net.lib.byu.edu/imaging/negev/Origins.html>> [Accessed 6 November 2013]. See also Joseph Naveh, *Early History of the Alphabet: An introduction to West Semitic Epigraphy and Palaeography* (Jerusalem: The Magnes Press, 1982), pp. 13-42

¹²² For more detailed discussion of the development of the vowels in Hebrew see Crawford Howell Toy and Wilhelm Bacher, 'Punctuation', in *The Jewish Encyclopedia*, ed. by Cyrus Adler (New York and London: Funk & Wagnalls, 1907)

¹²³ Naveh, *Early History of the Alphabet*, p. 11

¹²⁴ *Ibid.*, p. 10

¹²⁵ *Ibid.*, p. 175

¹²⁶ Herodotus *Histories* Book V.58

letter sequence, and the similarity to the earliest Greek letter forms.¹²⁷ Although this common ancestry had no impact on Hebrew typography in the period analysed in this thesis, it has been a factor in more recent Hebrew type design and the tendency to use more geometric shapes as models for Hebrew letterforms.¹²⁸

Given the dispersal of Jews in many countries and regions, place names often refer to wider 'geocultural' areas. The general consensus is that there are six major areas:

1. *Oriental scripts*: This covers scripts produced in the Middle East, Asia Minor, Iraq, Persia, Palestine, Egypt and Libya. Solomon Birnbaum included in this category Palestinian-Egypt, Egyptian, Babylonian, Persian, Maarvic or Eastern.¹²⁹ The oldest dated manuscript is from the fifth century AD.
2. *Yemenite scripts*: Birnbaum terms this Temanic. The oldest dated manuscript is from the twelfth century AD.
3. *Byzantine scripts*: Birnbaum terms this Yevanic. The oldest dated manuscript is from the fourth century AD.
4. *Italian scripts*: This category covers both Italy and Greece. The oldest dated manuscript is from about the third century AD.
5. *Sephardic Scripts*: (*Sefarad* is the Hebrew word for Spain) This covers the Iberian Peninsula, Provence, Languedoc, the North Apennine peninsula, Sicily. The oldest dated manuscript is from the sixth century AD.
6. *Ashkenazic scripts*: (*Ashkenaz* is the medieval Hebrew word for Germany) Covers Germany, central and northern France, England, central and eastern Europe. The oldest dated manuscript is from the eleventh century AD.¹³⁰

These geocultural units match very closely those listed by Colette Sirat, with the exception of the Yemenite manuscripts which she places under the Oriental category.¹³¹ They also match the regions used in the Sfardata Project, which contains at latest count some 2412 dated palaeographical units, or manuscripts from all the major geocultural areas in which Jews lived. The date range is from the tenth to the sixteenth century AD.¹³²

¹²⁷ Naveh, *Early History of the Alphabet*, p. 175 See also L. H. Jeffery, *The local scripts of archaic Greece: a study of the origin of the Greek alphabet and its development from the eighth to the fifth centuries B.C* (Oxford: Clarendon, 1990) for a more detailed discussion of these origins.

¹²⁸ For more discussion of this point, see Lubell, 'The Hebrew Typeface Designs of Zvi Narkis', pp. 221-222. See also Adi Stern, 'Aleph=X, or contemporary Hebrew bad type', in *Bad Type: Third annual Friends of St Bride conference* (St Bride, London, 2004)

¹²⁹ Birnbaum, *The Hebrew scripts*

¹³⁰ Andrzej Trzcinski, 'Badania paleograficzne nad pismem hebrajskim sredniowiecznym i nowozytnym (Palaeographic Studies on Medieval and Modern Hebrew Writing)', *Annales Universitatis Mariae Curie-Sklodowska*, II (2004), p. 71

¹³¹ Colette Sirat and N. R. M. De Lange, *Hebrew manuscripts of the Middle Ages* (Cambridge: Cambridge University Press, 2002), p. 184

¹³² Malachi Beit-Arié, 'The codicological Data-Base of the Hebrew Palaeography Project: A Tool for Localizing and dating Hebrew Medieval Manuscripts', in *Hebrew studies: papers presented at a colloquium on resources for Hebraica in Europe held at the School of Oriental and African Studies*

The Hebrew script is composed of 22 basic letters and five final letters. In addition there are 12 basic vowel points (*Nikkud* in Hebrew) which are generally placed below the letters, but in some cases above or in the middle. There are also the Dagesh points which are found in the centre of certain characters and indicate either their intensified (doubled) pronunciation, or, in the case of the letters – bet, gimmel, dalet, kapf, peh, and tav, their hard (unaspirated) pronunciation.¹³³ The letters have numerical equivalents which are used for dates, pagination in most Hebrew Biblical and religious texts and, since there are letters which may indicate words and the name of God, there are rules as to the way the letters may be combined. As in most of the Semitic languages, the script is a retrograde script and reads from right to left. The chart below summarises the Hebrew alphabet, the names of the characters, the difference between the Square Character (*Merooba* in Hebrew) and the Rashi Script, and names, the numerical values, the main accents and cantillation marks.¹³⁴ This chart may be used in conjunction with the assembled alphabets used throughout this thesis.¹³⁵

Name of character	Square Character	Rashi Character	Numerical equivalent
Aleph	א	א	1
Bet	ב	ב	2
Gimmel	ג	ג	3
Dalet	ד	ד	4
Heh	ה	ה	5
Vav	ו	ו	6

University of London 11-13 September 1989, ed. by Diana Rowland-Smith and P. Sh. Salinger (London: British Library, 1991)

¹³³ See 'Dagesh' (<<http://www.jewishencyclopedia.com/articles/4844-dagesh>> [Accessed 23 June 2011]. These are also called the 'begadkephat letters'. See also James D. Martin, *Davidson's Introductory Hebrew Grammar*. 27th edition (London and New York: Continuum/T & T Clark Ltd, 2006), pp. 20-21

¹³⁴ For more details on the cantillation marks, their names and positions, see Helmut Richter, 'Hebrew Cantillation Marks And Their Encoding' (<<http://www.mechon-mamre.org/c/hr/>> [Accessed 24 June 2011]. For more details on the vowel points and their position, see Martin, *Davidson's Introductory Hebrew Grammar*, pp. 13-19. See also Hebrew Range 0590–05FF, <<http://unicode.org/charts/PDF/U0590.pdf>> [Accessed 26 June 2011]

¹³⁵ The names of the Hebrew letters used in this thesis have been chosen for approximation to the current Israeli Hebrew pronunciation and after a comparison with other systems, such as the names used in the *Encyclopedia Judaica*, Davidson's *Introductory Hebrew Grammar* (2006) and the Unicode system. The guttural sound of the letter Chet (ח) is often indicated by a special glyph (h), also called an h-underdot, which is not always available in all online fonts, hence the alternate (Chet) was used. Within the text, the first mention of a Hebrew character has the actual Hebrew glyph within parentheses, e.g. aleph (א), thereafter without.

<i>Name of character</i>	<i>Square Character</i>	<i>Rashi Character</i>	<i>Numerical equivalent</i>
Zayin	ז	ז	7
Chet or het	ח	ח	8
Tet	ט	ט	9
Yod	י	י	10
Kaph	כ	כ	20
Final Kaph	ך	ך	N/a
Lamed	ל	ל	30
Mem	מ	מ	40
Final mem	ם	ם	N/a
Nun	נ	נ	50
Final Nun	ן	ן	N/a
Samekh	ס	ס	60
Ayin	ע	ע	70
Peh	פ	פ	80
Final Peh	ף	ף	N/a
Tsadde	צ	צ	90
Final Tsadde	ץ	ץ	N/a
Koph	ק	ק	100
Resh	ר	ר	200
Shin	ש	ש	300
Tav	ת	ת	500
Aleph lamed ligature	ל	ל	N/a
Vowel: Kametz	E	N/a	N/a

<i>Name of character</i>	<i>Square Character</i>	<i>Rashi Character</i>	<i>Numerical equivalent</i>
Vowel: Tsere	וֵי	N/a	N/a
Vowel: Patach	וּי	N/a	N/a
Vowel: Segol	וִי	N/a	N/a
Vowel: Kibbutz	וְי	N/a	N/a
Vowel: Chirek	וּיְ	N/a	N/a
Vowel: Shva	וּיִ	N/a	N/a
Vowel: Chateph Kametz	וֵיֶ	N/a	N/a
Vowel: Chateph Patach	וּיֶ	N/a	N/a
Vowel: Chateph Segol	וִיֶ	N/a	N/a
Vowel: Cholem	וֹ	N/a	N/a
Vowel: Cholem vav	בוּ	N/a	N/a
Punctuation: Sof Pasuq	⋄	N/a	N/a
Punctuation: Maqaf or Makaf	-	N/a	N/a
Punctuation: Geresh	'	N/a	N/a
Punctuation: Gershayim	”	N/a	N/a
Cantillation Mark: Atnach; Etnachta	⦿	N/a	N/a
Cantillation Mark: Segol; Sgol; Segolta	⦿	N/a	N/a
Cantillation Mark: Shalshelet	⦿	N/a	N/a
Cantillation Mark: Zaqef Qatan	⦿	N/a	N/a
Cantillation Mark: Zaqef Gadol	⦿	N/a	N/a
Cantillation Mark: Tipcha	⦿	N/a	N/a
Cantillation Mark: Revia	⦿	N/a	N/a
Cantillation Mark: Zarqa	⦿	N/a	N/a









<i>Name of character</i>	<i>Square Character</i>	<i>Rashi Character</i>	<i>Numerical equivalent</i>
Cantillation Mark: Pashta		N/a	N/a
Cantillation Mark: Yetiv		N/a	N/a
Cantillation Mark: Tvir		N/a	N/a
Cantillation Mark: Pazer (Qatan)		N/a	N/a
Cantillation Mark: Qarney Para (Fara); Pazer Gadol		N/a	N/a
Cantillation Mark: Tlisha Gdola		N/a	N/a
Cantillation Mark: Geresh		N/a	N/a
Cantillation Mark: (Munnach) Legarmeh		N/a	N/a

Fig. 1.10: The Hebrew Alphabet, vowel points and cantillation marks

The following diagram presents the same material in a different format and shows the set of Hebrew glyphs in the SBL (Society of Biblical Literature) Unicode Hebrew that is used in digital typesetting of Biblical texts.

	hAlef	hAlef.wide	hBet	hGimel	hDalet	hDalet.wide	hHe	hHe.wide	hVav	hZayin	hHet	hTet
	א	א̇	ב	ג	ד	ד̇	ה	ה̇	ו	ז	ח	ט
hYod	י	י̇	כ	ל	ל̇	ם	ם	מ	נ	ס	ע	
hAyin.alt	ע	ף	פ	ץ	צ	ק	ר	ר̇	ש	ת	ת̇	א̇
hAlefQam	א̇	א̇	ב̇	ב̇	ג̇	ג̇	ד̇	ד̇	ה̇	ה̇	ו̇	ו̇
hVavShin	ו̇	ז̇	ט̇	י̇	י̇	ך̇	ך̇	ך̇	כ̇	כ̇	ל̇	ל̇
hShinDageh	ש̇	ש̇	ש̇	ת̇	ת̇			׃	׃	׃		
hZarga	׃	׃										
hMerkhaK	׃	׃										
hHatafPatah	׃	׃										
hMaqaf	׃	׃										
Punctum	׃	׃										
	ה	ה̇	ח	ע								

Fig. 1.11: The Hebrew Alphabet, vowel points and cantillation marks for Unicode setting. (By permission of John Hudson of Tiro Typeworks, Gulf Islands, British Columbia, Canada)

The characters in the green cells represent the minimum number of glyphs necessary to set the text using a fully ‘decomposed’ approach in which all combinations are handled with mark positioning. The characters in the red cells are ‘precomposed’ Unicode characters, which would not be necessary in a fully decomposed approach.¹³⁶ The characters in blue cells are include extended letters, which are

¹³⁶ A fully decomposed Biblical Hebrew fount would be one in which each letter and each individual mark is handled as a separate glyph, and the interaction of the different marks applied to a single letter, their positioning relative to that letter, and the spacing relative to adjacent letters with marks is all handled dynamically through glyph positioning. Most implementations of Biblical Hebrew are

optional. The magenta cells are technical variants, i.e. glyphs that are useful to have for OpenType Layout purposes. The creator of this fount, John Hudson, estimates that the 'absolute minimum number' of glyphs necessary to display the Masoretic Bible text using modern OpenType Layout capabilities to be 85.¹³⁷ This number compares to the number of matrices for the Le Bé Hebrews listed in the 1730 Inventory as ranging from 61 to 101.¹³⁸ Note that this list does not include the aleph/lamed ligature (א), which is not used in Biblical composition, but is found quite frequently in Commentaries and Responsa literature.

These characters and accents can be related to what used to be termed 'founts' in typographic terminology: 'a set of related alphabets of one size and based on one design'. In Latin typography, a fount may consist of up to five sets of characters: upper and lower case roman, upper and lower case Italic, small capitals, and additional miscellaneous characters and spacing.¹³⁹ Gaskell has defined the term as 'a group of type-cast letters, numerals, signs etc all on one body and type-face'.¹⁴⁰ Vervliet has adopted a narrower definition of the term and differentiates between the terms type, typeface, casting or fount. He defines a type or typeface as referring to the ideal type, an abstraction which relates to the basic set of punches and from which are derived the matrices, the castings, the type as found in the printer's typefaces and ultimately the typefaces as they can be observed on the printed pages. This definition as described by Vervliet, ignores the 'traditional requirement for unity of time and place of casting' and also disregards minor variations that might be caused 'in the phases of justifying, casting, rubbing, kerning and dressing, or may be caused by broken or foul sorts, or by the inclusion of peripheral sorts, such as small caps, spaces ligatures, pronunciation or numerals, or the position of diacritics or strokes and dots'.¹⁴¹

This definition is perhaps more suitable to the description of Hebrew typefaces, as Hebrew types differ from Latin founts in a number of important aspects. Hebrew has no caps, no small caps, nor italic variants. Until modern times it had no true Arabic numerals. It may be produced in a pointed – vocalised or vowelled – version, but this variation involves the addition of the vowel or cantillation marks above or below the basic letter. Three basic varieties of Hebrew types available in the sixteenth century were square Hebrew (Merooba or Meruba), semi-cursive (also called Rashi or

built up of some hybrid of precomposed and decomposed approaches, with some letter+mark combinations being handled as ligatures. I am grateful to John Hudson of Tiro Typeworks for these clarifications.

¹³⁷ Email correspondence from John Hudson of Tiro Typeworks, Gulf Islands, British Columbia, Canada, 25 July 2013.

¹³⁸ Jean-Pierre Fournier and Stanley Morison, *L'Inventaire de la Fonderie Le Bé. Selon la transcription de Jean Pierre Fournier*. [Edited, with an introduction, by Stanley Morison.] (Paris: Documents Typographiques Français, 1957), p. 22

¹³⁹ Hugh Williamson, *Methods of Book Design: The practice of an industrial craft* (London: Oxford University Press, 1956), p. 37

¹⁴⁰ Gaskell, 'A nomenclature for the Letter-forms of Roman Type', p. 44

¹⁴¹ Vervliet, *French Renaissance Printing Types: A Conspectus*, pp. 57-58

Rabbinic), and Yiddish (also a form of semi cursive). The cursive form, which only recently historically has become a typographic form, was also known as Kurrent.¹⁴²

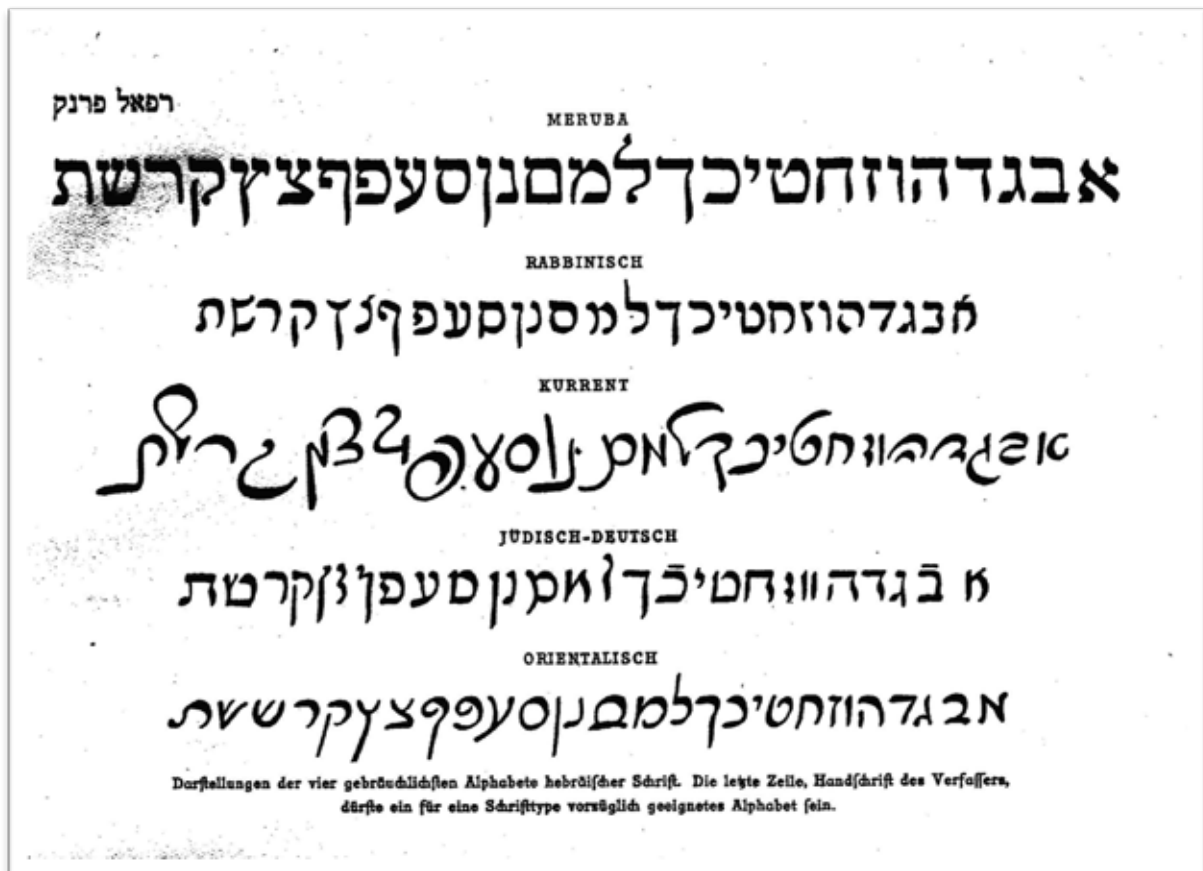

Fig. 1.12: The basic varieties of Hebrew types (Raphael Frank, *Über Hebräische Typen und Schriftarten*, 1925)

It is thus not useful or correct to speak of Hebrew founts in terms of families of types as would be relevant to Latin typography. The most accurate definition in relation to Hebrew would be individual typefaces which relate to specific punches where they can be identified or, where this is not possible, to certain common recognition elements or size.

Yiddish type is an interesting case in itself and does not figure in any of the Le Bé specimens. This emphasizes the complexities in the Hebrew printing world in the sixteenth century, although Yiddish type was used in Italy in Cremona, Mantua, Verona and Venice, as well as in the German-speaking lands north of the Alps. It is a fair assumption that Le Bé would have been aware of Yiddish both as a language and as a typeface, but for reasons perhaps related to the dominance of the Sephardic letter forms, he chose to ignore it in his specimens.

Rabbinic (Rabbinisch) has been given a variety of names and it is not always clear if they are referring to the same scribal hand of typeface. It is well represented in the Le Bé specimens and thus of interest as to its origins and role in Hebrew printing in the sixteenth century.

¹⁴² Frank, *Über Hebräische Typen und Schriftarten*, p. 25

Bernheimer refers to 'rabbinico' as one of the 'tre tipi fondamentali di scrittura', the other two being 'quadrato' and 'corsivo'.¹⁴³ Birnbaum later introduced the term 'Mashait', which he saw as being the correct terminology and which comes from Jewish Halakhic literature, which he writes 'has been the designation for cursive and rabbinic styles since the about the twelfth century'. He writes further that the term 'Rabbinic' had been incorrectly introduced at early stages of the cataloguing of Hebrew manuscripts and that rabbis had no closer connection with this style than with the square or cursive. Birnbaum asserts that 'books of any kind, and not only Halakhic, were written in Mashait'.¹⁴⁴

Despite Birnbaum's preferences, the term 'Mashait' does not appear to have gained much favour in recent studies of Hebrew palaeography, and Colette Sirat uses the term Rashi script and she writes that 'the Talmud printed by the Soncino family produce the commentaries of Rashi in a Sefaradic type embellished with an Italian roundness. Although this style of lettering is commonly known today as "Rashi", it has nothing whatever to do with the writing used by the French Jewish scholar of the eleventh century'.¹⁴⁵

Many of the codicological elements of medieval Hebrew manuscripts were carried over into the early printed books.¹⁴⁶ These elements included the actual scripts, auxiliary graphic signs, substitutes for the tetragrammaton, devices for producing even lines, means for preserving the order of the gathering or the sheets, formulae at the beginning and end of a book, the wording of colophons and ways of producing justified left margins – justification in typographic terminology.¹⁴⁷

The last element, the justified left margins, is a major area which affected sixteenth-century punchcutters of Hebrew such as Le Bé, and determined some of the characters they needed to cut. Hebrew incunabula used such devices as filling in the space with as many letters as would fit and then writing the complete word in the next line, or using graphic fillers or certain random letters, or the use of dilated letters. These devices appear to have been used quite widely in Hebrew printing in Spain. Beit-Arié comments that 'the Italian printers and compositors employed either, at the beginning, no scribal devices at all, or later mainly a single scribal device. Thus the early Italian Hebrew presses demonstrate their detachment from the scribal tradition'.¹⁴⁸ It seems clear that the dilated letters shown in some of the typefaces cut by Le Bé follow in this tradition, which he would surely have known from the period he spent in Venice and his earlier apprenticeship with Robert Estienne in Paris. The device of dividing words at the end of lines, already evident in

¹⁴³ Bernheimer, *Paleografia ebraica*, p. 19

¹⁴⁴ Birnbaum, *The Hebrew scripts*, pp. 189-190

¹⁴⁵ Sirat and De Lange, *Hebrew Manuscripts*, p. 186

¹⁴⁶ See Malachi Beit-Arié, 'The relationship between Hebrew Printing and handwritten Books: Attachment or Detachment', in *The Makings of the Medieval Hebrew Book*, ed. by Malachi Beit-Arié (Jerusalem: The Magnes Press, 1993), p. 254

¹⁴⁷ *Ibid.*, pp. 253-254

¹⁴⁸ *Ibid.*, p. 265

the Gutenberg Bibles, was not carried over into Hebrew printing. Le Bé was well aware of this tradition and its implications for the design and composition of Hebrew texts, as is evidenced by his comment in one of the Paris documents.¹⁴⁹

Another scribal element carried across into early Hebrew printing was the use of a small superscript circular mark above certain letters to indicate cross references in the side columns. These references are found in the margins of the text, and are often indicated by superscript semi-cursive letters above the relevant word in the text, or by a small superscript circle or circumcellus, which is originally a Masoretic mark indicating either a cross reference or a necessary correction.¹⁵⁰ This *circumcellus* or *signe de renvoi* is also found in some of the specimens used by Le Bé and it is likely that he was asked to cut such a symbol by the printers for whom he worked, although no such accent appears in the smoke proofs assembled by Harry Carter in 1954.¹⁵¹ This same sign is also found in various extant manuscripts, so it was clearly carried over to print from scribal practices.¹⁵² There is in fact an example of this sign (punch number 12) in the set of punches numbered ST51, the Double Augustine Ashkenazi vowels and intonations, in the Plantin Moretus Museum. As this sign could be placed over any letter in a word, it would have been treated as any other vowel or cantillation mark for the purposes of striking matrices and casting.

¹⁴⁹ Omont, *Specimens de caractères hébreux, grecs, latins, et de musique gravés à Venise et à Paris par Guillaume le Bé, 1545-1592*, pp. 10-11

¹⁵⁰ I am indebted to Dr Willem F. Smelik of the Department of Hebrew and Jewish Studies at UCL for this information. It may also indicate a ketiv/qere sign. This refers to a number of differences between what is written in the consonantal text of the Hebrew Bible, as preserved by scribal tradition, and what is read. This is also called a “signe de renvois” in paleography. See Philippe Bobichon, *Le lexicon: Mise en page et mise en texte des manuscrits hébreux, grecs, latins, romans et arabes*. Vol. CNRS: UPR841 (Paris: Institut de recherche et d'histoire des textes (IRHT), 2009)

¹⁵¹ Harry Carter, 'Specimen types from the matrices at the Plantin-Moretus Museum, cast by H.G.C. 1954', (Oxford: University Press, 1955), p. 7

¹⁵² See Birnbaum, *The Hebrew scripts*, pp. examples 241 and 242, Sephardic Manuscripts from 800 to 1000 and 1222.

Chapter 2: Le Bé's types during his apprenticeship with Robert Estienne and in Venice

Le Bé's early years and his apprenticeship with Robert Estienne

The subject of this thesis, the punchcutter Guillaume I Le Bé was, as stated in the entry on him in the Le Bé Memorandum, a 'natif de Troyes en Champa[gne]'.¹⁵³ He was born into a family with long roots in the papermaking industry in Troyes and this connection, as will be seen, was undoubtedly a key element in his entry into the Parisian print world.

The exact date of his birth is not certain, as no baptismal registers have survived in the regional archives in Troyes from that period.¹⁵⁴ Le Bé gives an accurate indication of his birth date in Fr. Nouv. Acq. 4528 when he writes that his first type was cut in 1545 when he was 'aagé alors de 20 ans et huit mois'.¹⁵⁵ This would place his birth date in April 1525. A contradictory note in the same document gives his age as 68 in June or July 1592, which would place his birth year sometime in 1524.¹⁵⁶ In yet another note in MS 1665, Le Bé writes that he cut a Hebrew Texte Moyen in 1546, 'aagé de 20 a 21 ans'.¹⁵⁷ Whichever of these notes is correct, we can thus date his birth between 1524 and 1526. The most probable date is sometime in 1525, as his son Guillaume II Le Bé wrote that his father 'partit de Paris vers le mois d'octobre 1545 et fut demeurer à Venise premierement, auquel lieu ayant atteint l'aage de 20 ans ...'. This is albeit a second-hand recollection, but appears to confirm the first date of April 1525.¹⁵⁸

Le Bé's family roots in papermaking in the region of Troyes in Champagne have been traced in detail by the archivist Louis Le Clert. Le Clert's two-volume history of paper in Troyes represents a lifetime's research in local archives. He gives the first mention of a Le Bé (also given as Le Ber) as a *paupleur* (*papetier*) from 1405, when a Guyot I Le Ber is listed as 'locataire d'un des moulins à papiers à Saint-Quentin'.¹⁵⁹ What is of importance is that he lists a Guillaume I Le Ber who was active as *papetier juré* in the late fifteenth century, who may well have been the grandfather the subject of this thesis.¹⁶⁰

¹⁵³ Le Bé, *The Le Bé memorandum*, p. 21

¹⁵⁴ Email communication from the Archives départementales de l'Aube, dated 28/12/2011, which confirms that 'notre service ne conserve pas d'actes ou certificats de baptême à Troyes avant 1535'.

¹⁵⁵ Guillaume Le Bé, 'Epreuves de lettres que j'ay taillées, tant en six et sept sortes de poinçons de lettres hebraïques, que autres lettres, en divers temps et pour diverses personnes et partie aussy pour moy', (Paris: Bibliothèque nationale de France, ?)N.A. fr-4528, f. 1

¹⁵⁶ *Ibid.*, p. 13 (folio)

¹⁵⁷ Guillaume Le Bé, 'Spécimens de caractères hébreux gravés à Venise et à Paris par Guillaume Le Bé (1546-1574)', (Paris: Bibliothèque Nationale, ?)RES- X- 1665, f.10

¹⁵⁸ Le Bé, *The Le Bé memorandum*, p. 21

¹⁵⁹ Louis Le Clert, *Le Papier. Recherches et notes pour servir à l'histoire du papier, principalement à Troyes et aux environs depuis le quatorzième siècle, etc* (Paris: A L'enseigne du Pégase, 1926), p. 356

¹⁶⁰ *Ibid.*, p. 359

It was very common in early modern France to have successive generations with the same given name, yet for the purposes of this thesis and to avoid confusion, it seems best to keep to the titles adopted for the Le Bé generations started by Guillaume I Le Bé the punchcutter. It is a safe assumption from the available evidence that Guillaume I Le Bé was probably the fifth generation of Le Bé's to bear the name Guillaume. Both his son (Guillaume II Le Bé) and grandson (Guillaume III Le Bé) were also named Guillaume and were involved in the typefoundry established by their father and grandfather Guillaume I Le Bé.

Le Clert was aware of the importance of the Le Bé family in papermaking, as he wrote: 'il n'a pas encore été publié de généalogie de la famille Le Bé et nous croyons qu'il n'en existe aucune à l'état manuscrit: c'est une lacune regrettable pour l'histoire de notre cité et de son industrie, les Le Bé s'étant distingués par l'importance qu'ils firent prendre à leurs fabriques de papier et par la perfection qu'ils donnèrent aux produits sortant de ces usines'.¹⁶¹ Le Clert also provides a comprehensive list of specimens of Le Bé watermarks used from the period of Jean II Le Bé (from 1459 to c. 1488), Guillaume I Le Bé (from c. 1523), Guillaume II Le Bé (from 1523 to c. 1560), Denis Le Bé (from 1548), Nicolas Le Bé (from 1550 to 1605), Edme Le Bé (from 1550 to 1593), Jacques I Le Bé (from 1574 to 1607) and Jacques II Le Bé (from 1607 to 1642).¹⁶² This selection complements the far more comprehensive work of Charles Briquet.¹⁶³

Elizabeth Armstrong commented on the frequent use of paper with the Gothic P watermark, which Briquet ascribes to the Piétrequin family, as well as a less frequent use of a compass, a watermark 'belonging to a member of the Le Bé family, related to the Piétrequin family'.¹⁶⁴ It will be seen from the chart below that Nicolle Pietrequin (Pétrequin) may well have been the mother of the subject of this thesis and thus it was quite natural to place him in an apprenticeship in an allied printing trade. As will be discussed later, no documentary evidence has yet been found for this apprenticeship and the reasons for this lacuna may reflect the close relationship between the Estienne family and Le Bé papermaking dynasties in Troyes.

Le Clert's searches and annotations are not easy to follow and a later archivist, Comte François Chandon de Briailles, compiled a more logical genealogical listing based on Le Clert and other archival sources.¹⁶⁵ Figure 2.1. shows a modified listing of the Le

¹⁶¹ Le Clert also refers to two other genealogical listings which contain information on the Le Bé dynasties: The Cabinet d'Hozier in the BNF (Tome XXVII, page 217) and the notes compiled by Comparot de Longsols in the Bibliotheque de Troyes (A.D., E. 927 and 928). However Le Clert found these two sources less than satisfactory as regards accuracy and dates.

¹⁶² Le Clert, *Le Papier*, pp. 353, 374-380

¹⁶³ Briquet, *Les Filigranes*

¹⁶⁴ Elizabeth Armstrong, *Robert Estienne royal printer: an historical study of the elder Stephanus* (Sutton Courtney: The Sutton Courtney Press, 1986), p. 56

¹⁶⁵ Comte Chandon de Briailles, 'Le Fichier Chandon' (2004) <http://www.archives-aube.com/arkotheque/fonds_chandon/index.php> [Accessed 8 April 2013]. Le Généalogie Hennequin, manuscript Ms 2601 held in the state archives in Troyes, does not mention the Le Bé

Bé family active in paper making in Troyes in the fifteenth and sixteenth centuries based on the Fichier Chandon. The probable direct descendants leading to Guillaume Le Bé the punchcutter are highlighted in **bold**. The Cabinet d'Hozier mentions seven children for Guillaume I Le Bé : Guillaume, marchand a Paris/ Robert, marchand /François, marchand/ Adrien, marchand /Nicolas, Papetier (marié à Françoise Belin)/Jean (AN Y.3374 16 juin 1548).

The nineteenth century bibliographer and librarian Emile Socard writing in 1882 confirms this genealogy. He wrote that 'Guillaume II Le Bé' (this is based on Guillaume the punchcutter as being the second in line to carry this name) 'était fils de Guillaume I^{er} le Bé et de Madeleine de Saint-Aubin et petit-fils de Pierre', but claimed incorrectly that 'il ne continua pas le commerce de papiers de son père' and also insisted that his date of death was about 1610 and not 1598. This confusion stemmed from the publication in 1609 of Jean Cinquearbres's *Linguae Hebraice Institutiones* by Guillaume 'II' the successor to the family firm.¹⁶⁶

Both the probable grandfather and father of Guillaume I Le Bé the punchcutter were named as a *papetier-juré* of the University of Paris. Charles VIII reconfirmed the privileges of the 'les ouvriers et faiseurs de papier Jean Le Bé demeurant à Troyes' as a *papetier-juré* of the University of Paris in March 1489 and in January 1518 Guillaume Le Ber resigned from his office as *papetier-juré* of the University of Paris in favour of his son Jean.¹⁶⁷ Boutiot in his history of Troyes notes that 'les papetiers en réputation furent les Leber ou LeBé, qui fabriquèrent pendant plusieurs générations et possédèrent plusieurs fabriques sur la Seine, les Nivelles, les Denise, les Debure etc.' and he also confirms that 'les Estienne se fournissaient à Troyes'.¹⁶⁸

The close connection between the Estienne and Le Bé families is confirmed by the *Le Bé Memorandum* which recounts that Guillaume I Le Bé, on his return from Rome in 1550, travelled to see his former master Robert Estienne, then newly established in Geneva. Estienne gave him letters of recommendation to 'Guillaume le bé son pere, marchand papier à Troyes, qui auroit fourny tout les papiers de ses impressions tant de bibles que autres'.¹⁶⁹ Gosley in his history of Troyes confirms this when he wrote of the Le Bés, 'premiers papetiers-jurés de l'Université de Paris, (qui) fournissaient la matière sur laquelle roulaient les célèbres imprimeries des Colines, des Estiennes, des Vascovans'.¹⁷⁰

family in any detail. See Frédéric de Berthier, *Les Anciennes familles de Troyes* (Neuilly-sur-Seine: Collection Monte Cristo, 2006)

¹⁶⁶ Emile Socard, *Biographie des personnages de Troyes et du département de l'Aube* (Troyes: Librairie Léopold Lacroix, 1882), p. 249

¹⁶⁷ See Theophile Boutiot, Henry Boutiot, and Alexis Silvetre Det, *Histoire de la ville de Troyes et de la Champagne méridionale* (Troyes and Paris: Auguste Aubry and Dufey-Robert, 1870), Le Clert, *Le Papier*, p. 360. I am grateful to Jacques Schweitzer of Troyes for alerting me to the first document.

¹⁶⁸ Boutiot, Boutiot, and Det, *Histoire de la ville de Troyes et de la Champagne méridionale*, p. 547

¹⁶⁹ Le Bé, *The Le Bé memorandum*, pp. 21-22

¹⁷⁰ P.J. Grosley, *Ephermerides* (Paris: Chez Durand et Brunot-Labbe, 1811), p. 146 (Tome I)

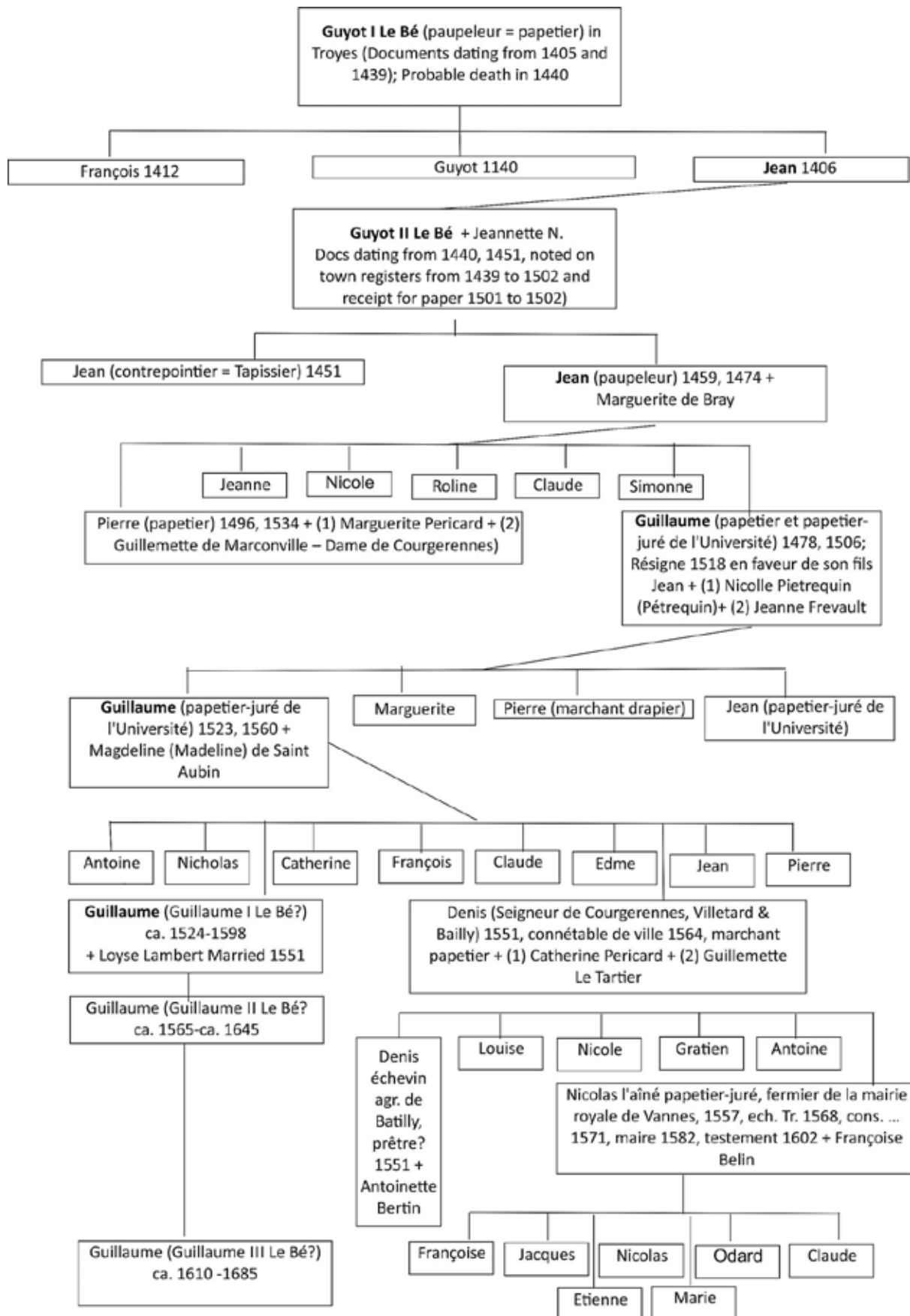

Fig. 2.1: The Le Bé family tree based on Le Clert and the Fichier Chandon

There are two additional possible members of the Le Bé family with a connection to letter engraving. The first is Pierre Le Bé, the author of *Béle Prérie* (an anagram of his name) or *Modèles de Lettres* printed in 1601. His connection to the Le Bé paper dynasty has never been established. The title page of this publication gives his place of origin as Bar-sur-Aube near Troyes and names him as a 'Maistre ecrivain juré' à Paris. This is the only publication known to his name and contains an early attempt at geometrically constructed roman and italics letters. There are no Hebrews shown, yet the name, close geographical location and similar professional activity do point to a possible family connection.¹⁷¹ The second is André Le Bé, also a 'maistre ecrivain juré' à Paris', whom Ellic Howe describes as the brother of Guillaume II Le Bé and who engraved two manuals on how to write 'lettres bastarde'.¹⁷² Thus there appears to a clear thread running through the Le Bé family linking them to letter engraving of one sort or another.¹⁷³

The civic and personal status of the papetiers in Troyes can be judged by this except from a poetic description of the entry of Charles VIII into Troyes in the year 1486. Grosley claims that it was written by N. Le Bé - 'l'un des suppôts de la florissante papeterie qu'avait dès-lors la ville de Troyes: de ce Le-Bé descendait le savant Guillaume Le-Bé, élève de Robert Estienne ...' It is not clear who exactly this N. Le Bé was. It may have been the Nicolas Le Bé mentioned in the Cabinet Hozier genealogical list, which would have made him an uncle of Guillaume I Le Bé the punchcutter.

Aussi y feurent de Troyes les papetiers,
 En très-grand pompe, habillez de migraine,
 Et bien montez sur beaux puissans destriers,
 De bardure couverts très-belles et saine;
 Pour y venir, laisserent courir Seine,
 Leverent vanes, delaisant leurs molins;
 Ung chascun d'eulx grant joie si démaine,
 Tous y avoient beaux pourpains de satin.¹⁷⁴

¹⁷¹ Pierre Le Bé and Jan Tschichold, *A Book of Letter Forms by Pierre Le Bé, Paris 1601/Ein Buchstabenbuch von Pierre le Bé, Paris 1601/Modeles de lettres de Pierre le Bé* (Stuttgart-Bad Cannstatt: Cantz'sche Druckerei, 1974). See also Claude Mediavilla, *Histoire de la calligraphie française* (Paris: Albin Michel, 2006), pp. 190-191

¹⁷² Roger-Armand Weigert, *Inventaire du fond français, graveurs du XVIIe Siecle* (Paris: Bibliothèque nationale, 1939-1973), pp. 291-292 (Tome II)

¹⁷³ There is also a mention of a Joseph Le Bé, 'mon cousin marchand demeurant au bout de ruë longue à Lyon' in the letter written by Guillaume II Le Bé in Novembre 1614. This letter written to Pierre Mourier, 'Maistre Fondateur de lettres demeurant à Geneve' was a warning against attempts by certain booksellers in Paris and Lyons who were attempting to purchase matrices to set up their own type foundries. The relationship to Guillaume I Le Bé is not clear, but given the dates he would most likely be a nephew. This letter is found in the Anisson-Duperron archive in the BnF.

¹⁷⁴ Grosley, *Ephemerides*, pp. 126, 129 (Tome I). Migraine = sorte d'étoffe teinte avec la graine de chochenille ; destriers = chevaux de mains and bardure = armure en lames.

Nothing is known of the earlier education of Guillaume I Le Bé, the punchcutter, but it may be assumed that, given the high social status of his family, that he would have received some lessons in French and Latin. There was in fact a humanist college in Troyes, established by the 1530s¹⁷⁵ and this is where the Flemish scholar Nicholas Stiltère – a ‘personnage assez bien versé en la langue latine, et aucunement en la grecque’ - was a principal and appears to have used his position to instruct students in the new reformed religion.¹⁷⁶ Given Guillaume I Le Bé’s exposure to alternative religious views and to a more tolerant view of other religions during his apprenticeship with Robert I Estienne, it appears highly likely that he was aware of such divergent opinions, but wisely chose to keep his allegiances to himself given the violence of the years of the French Wars of Religions, to which he was a witness.

The Estienne Hebrews and Le Bé’s involvement in them

There is no extant document recording Guillaume I Le Bé’s apprenticeship with the printing office of Robert I Estienne. Such a document would most likely have been drawn up by a notary near the Estienne printing office in Paris, as can be seen by the documents which have survived and which list apprenticeships to printers and type founders. Most of them are in a standard format, and list the name and age of the apprentice, the period of apprenticeship, the obligations of the printers and occasionally the obligations of the apprentice towards his master.¹⁷⁷ The average age of entry appears to have been 10 or 13, but an apprenticeship document from July 1541 mentions a young boy, Nicholas de la Ruelle, aged five and a half, who was placed into service and apprenticeship with the illuminator Jean Legay for a period up to his twelfth birthday. This may have been unusual, but Legay undertook to ‘envoyer à l’escolle et luy faire apprendre les sept pseaulmes, heures et aultre service, et ce faict, l’entretenir quelque temps au colleige pour apprendre la science’.¹⁷⁸

Another typical example relating to type founders is the following from a document from 1538: ‘Engagement par Jean Josse le jeune, fils de Jean Josse l’aîné, qui le 23 septembre 1538, s’était mis en apprentissage pour 4 ans, chez Alexandre Beaujouan, fondateur de lettres à Paris, et qui avait quitté son maître ayant encore 2 ans à le servir, pour apprendre le métier de compositeur en Imprimerie, de rentrer pour 3 ans au service de son maître, qui lui fournira le gîte et le couvert et lui donnera 9 l.t. (livres

¹⁷⁵ Penny Roberts, *A city in conflict: Troyes during the French wars of religion* (Manchester; New York: Manchester University Press and St. Martin's Press, 1996), p. 13

¹⁷⁶ Le service éducatif de la MGT (Médiathèque du Grand Troyes), ‘Les Pithou, une Famille au Coeur des Guerres de Religion’ (2012) <http://www.cndp.fr/crdp-reims/fileadmin/documents/preac/patrimoine_mediathèque_troyes/3-Les_Pithou__une_famille_au_coeur_des_guerres_de_religion_site_academique.pdf> [08 February 2012] The word ‘aucunement’ can mean ‘en quelque sorte’ or ‘à certains égards’ in this context. (See Dictionnaire de l’Académie française, 4th Edition 1762)

¹⁷⁷ For a fuller discussion of this topic see Chapter II of H. Hauser, *Ouvriers du Temps Passé* (Paris: Félix Alcan, Editeur, 1906)

¹⁷⁸ Ernest Louis Coyecque, *Recueil d’actes notariés relatifs à l’histoire de Paris et de ses environs au XVIe siècle. 1, 1498-1545. 2, 1532-1555, Histoire générale de Paris*. (Paris: Imprimerie nationale, 1905), p. 336

tournois)'. Yet another document from 1541 reads 'Mise en apprentissage, pour cinq ans, par Jean le Gal, marchand des chevaux, place Maubert, de son fils, Pierre le Gal, âgé de 12 ans, chez Riolle du Bois, fondeurs des lettres, à Paris, qui lui fournira le gîte et le couvert'.¹⁷⁹

It is also known that the punchcutter Claude Garamont¹⁸⁰ had at least four apprentices in his service during the period 1543 to 1558, but it was noted that 'il n'apprend pas son art de graveur mais le métier de fondeur'.¹⁸¹ The known apprentices taken on by Garamont were Pierre Legat in 1543, Anselme le Bigot in 1551, Jehan de Preau in 1557 and Paterne Robelot in 1558. In all four cases Garamont undertook *only* to 'enseigner ledict mestier de fondres lectres' or 'enseigner à son povoyr le dict estat de fondeur de lettres', and not to instruct these apprentices in punch cutting or in the justification of matrices. It is noteworthy that these documents describe Garamont as *tailleur et fondeur de lettres* or in one document as *tailleur et graveur de lettres grecques*.¹⁸²

This lack of clear distinction between punchcutters and founders in this period is further reinforced by the *Lettres Patentes* issued by François I^{er} at Villiers-Cotterêts on the 31st August 1539. This edict set out quite specifically the obligations and duties of both masters and apprentices, and appears to be aimed at controlling the often unruly behaviour of the apprentice printers in both Paris and Lyons during this period.¹⁸³ What is interesting for the purposes of this thesis is the distinction made in the edict between printers (imprimeurs) and type founders (fondeurs des lectres).¹⁸⁴ The original text in clause 18 reads as follows:

Item, et pour ce que le mestier des fondeurs des lettres est connexe à l'art d'ymprimeur et que les fondeur ne se dysent imprimeurs, ne les imprimeurs ne se dysent fondeurs, lesdits articles et ordonnances auront lieu, quant aux

¹⁷⁹ *Ibid.*, pp. 310, 397

¹⁸⁰ See Mosley, 'Garamond or Garamont?' for a discussion of what form should be used for Garamond's surname. The accepted practice appears to be that 'désormais d'usage d'écrire Garamond pour désigner une police de caractère, et Garamont pour citer le graveur'. I have retained the spelling Garamond in this thesis only where cited from other publications. See Ministère de la Culture et de la Communication, 'Garamont ou Garamond?' (<http://garamond.culture.fr/fr/page/garamont_ou_garamond> [Accessed 6 November 2013])

¹⁸¹ A. Parent, *Les métiers du livre à Paris au XVI^e siècle (1535-1560)* (Geneva: Librairie Droz, 1974), p. 75

¹⁸² These documents are found in the Archives Nationales respectively in ET/CXXII/1246, ET/LXX/45, ET/LXXIII/51, and ET/LXXIII/23.

¹⁸³ Paul Chauvet, *Les ouvriers du livre en France: des origines à la Révolution de 1789*. [1. *d.] (Paris: Presses universitaires de France, 1959), pp. 19 -34. See also Hauser, *Ouvriers du Temps Passé*, Chapter X

¹⁸⁴ Emile Levasseur and Académie des sciences morales et politiques, *Ordonnances des rois de France: règne de François I^{er}* (Paris: Imprimerie nationale, 1902), pp. 672-685. See also *Lettres patentes de François I^{er} portant règlement des compagnons et apprentis imprimeurs 31 août 1539* (Arch Nat. 3e Vol des Bannières, Y9 fol. 162 v, Coll. Lamoignon t. VI, fol. 558)). See also René de L'Espinasse, Etienne Boileau, and François Bonnardot, *Les métiers et corporations de la ville de Paris, Histoire générale de Paris*. (Paris: Imprimerie nationale, 1879)

amendes, inhibitions, deffenses et peines dessusdites, aux compaignons et apprentils fondeurs ainsi que ès compaignons et apprentils imprimeurs, lesquels, outre les choses dessusdites, seront tenuz de achever les fontes des lettres par eulx encommencées, et de les rendre bonnes et vallables, autrement seront tenuz aux interestz et dommaiges des maistres; et commenceront à besongner par chaque jour à cinq heures du matin et pourront delaisser à huit heures du soir, qui sont les heures acoustumées d'ancienneté.¹⁸⁵

This appears to be the first instance 'to distinguish the type founders from the printers, although its regulations were applicable to both professions', yet 'it remains silent on punch cutting'.¹⁸⁶ The conclusion to be drawn from this edict is that, at the time, the professions of punchcutter and type founder were often conflated and thus there was no need to distinguish between them, at least with regard to the printing trades.

Vervliet has pointed out that it was the case in the sixteenth century that independent punchcutters often ran a typefoundry at the same time, and he cites the cases of Claude Garamont and Hendrik van der Keere, who were both punchcutters and owned or had an association with a typefoundry.¹⁸⁷ It may thus be the case that the term *fondeurs des lettres* also covered *graveurs* or *tailleurs de lettres*.

The profession of engraver (*graveur*) most certainly existed during the sixteenth century, especially when it was applied to those craftsmen who engraved medals (*médailles*), tokens (*jetons*), or coins (*monnaie*). Natalis Rondot's comprehensive study of such craftsmen lists a total of 365 *graveurs* of different specialities (for example 239 *graveurs de monnaie*, 50 *graveurs de jetons*, and 40 *graveurs de médailles et médailles*) during the whole of the sixteenth century.¹⁸⁸ He does not list any *graveurs de caractères d'imprimerie* and this may point to the way that engravers of printing type viewed themselves, the *graveurs de médailles et médailles* being the more 'artistic' end of the profession.

It may also point to a semantic confusion between the terms *graveur* or *engraveur* and *tailleur* which one finds commonly in the Le Bé documents and as late as Fournier's *Manuel Typographique* of 1764. The two terms tended to be used interchangeably when referring to punch cutting, to indicate both to engrave and to cut. Natalis Rondot comments that 'la qualité d'engraveur a été donnée rarement à des maîtres' which may imply that it was considered a higher form of craftsmanship.¹⁸⁹ A survey of Fournier's *Manuel Typographique* shows that the term *tailler* was used in some ten instances and the term *graver* in some 23 instances to apply to much the same action. The use of *tailler* seems to indicate the

¹⁸⁵ Levasseur and politiques, *Ordonnances des rois de France: règne de François Ier*, pp. 680-681

¹⁸⁶ Vervliet, *French Renaissance Printing Types: A Conspectus*, p. 30

¹⁸⁷ *Ibid.*, p. 28

¹⁸⁸ Natalis Rondot and Henri de La Tour, *Les Médailleurs et les Graveurs de monnaies, jetons et médailles en France* (Paris: Ernest Leroux, Editeur, 1904), p. 4

¹⁸⁹ *Ibid.*, p. 13

action of tracing (e.g. 'il faut *tailler* d'abord cette figure sur une petite tige d'acier' on page 9), whereas Fournier speaks in general of '*graver* les caracteres'.¹⁹⁰ Lothar Wolf gives the definition of *tailler* as 'graver, former en relief les caractères à l'extrémité des tiges d'acier', and *graver* as 'tracer sur une matière dure, en l'entaillant, au moyen d'un burin, d'un ciseau'.¹⁹¹ It should also be noted that Harry Carter's translation of Fournier uses the term *to cut* or *letter cutter* to cover both French terms, whereas the closer meaning may well be 'engrave' for *graver* and 'trace' for *tailler*.¹⁹²

If we return now to Guillaume I Le Bé and his period of apprenticeship with Robert I Estienne, several terms have been used by various sources to describe that period.

In the *Le Bé Memorandum* Guillaume II Le Bé writes quite specifically that his father 'fut mis apprentif chez Robert Estienne Laisné et premier en lan 1539 ou 40 auquel il apprit la librairie, imprim[erie] et fonderye le lettres et graueure dicelles'.¹⁹³ This statement is repeated in the section on Robert Estienne, when discussing the Hebrew type cut by Jean Arnoul, where Guillaume II Le Bé writes that his father 'estoit alors apprentif chez ledit Estienne en 1542 et il travailla sur la fin auxdits caracteres'.¹⁹⁴ This last statement is important, as it establishes that Guillaume I Le Bé worked on some of the Estienne Hebrews and this point will be discussed later in this chapter.

There is in fact a record of another apprentice taken on by Robert Estienne in 1539. The name of the apprentice was Loys Mauffans, and he appears to have been recommended by 'Maistre Jehan Chappel, estudiant en la faculté de medecine'. Unfortunately no further information is available on this apprentice.¹⁹⁵ What this may indicate is that Robert Estienne relied on personal connections and acquaintances to find apprentices and may have employed a more informal type of 'exchange of favours' rather than a formal notarial contract.¹⁹⁶

Subsequent mentions of Le Bé's apprenticeship use other terms, such as *élève* and *disciple*. The series of articles and replies which began with an anonymous letter to the *Journal des Sçavans* in Janvier 1756 mentions Le Bé as a 'disciple de Robert Estienne', and a later reply maintained that Le Bé 'n'a jamais été élève de Garamond; il estoit disciple de Robert Estienne'. The letter, still unsigned but most probably written by Fournier l'aîné, given the accurate references to comments from the Paris

¹⁹⁰ Pierre-Simon Fournier, '*Manuel Typographique*', 1764)

¹⁹¹ Karl Lothar Wolf, *Terminologische Untersuchungen zur Einführung des Buchdrucks im französischen Sprachgebiet* (Tübingen: Niemeyer, 1979), pp. 21-22

¹⁹² Fournier and Carter, *Fournier on Typefounding*

¹⁹³ ...and was apprenticed to Robert Estienne the Elder and the first of the name in 1539 or 40. There he learned bookselling, printing, letterfounding and letter-cutting.

¹⁹⁴ Le Bé, *The Le Bé memorandum*, pp. 17, 21, 29, 32 (My father was apprentice to Robert Estienne, that is to say in 1542, and he worked at these letters towards the end.)

¹⁹⁵ Armstrong, *Robert Estienne royal printer: an historical study of the elder Stephanus*, p. 281 (1986 revised edition) I have not been able to trace the references given for this detail.

¹⁹⁶ I am grateful to Mme Geneviève Guilleminot, Réserve des livres rares of the BnF, for this suggestion.

documents and the Le Bé memorandum, adds that ‘son pere, Marchand de papiers à Troyes, qui fournissoit Estienne, le pria de recevoir son fils, qu’il lui envoya à l’âge de 15 ans’. And the signed letter sent by Fournier l’aîné in May 1756 to the *Mercur de France* contradicts the earlier statement and maintains that ‘ce même le Bé, élève de Garamond, s’est appliqué à graver ce que son maître n’avoit pas fait, sçavoir des caracteres hébreux, Rabiniques et Arabes ...’¹⁹⁷ The meanings given the term, *disciple*, for example, in the sixteenth to the eighteenth centuries may have been closer to ‘a schollar, a learner, a pupill’ or ‘qui apprend quelque science ou quelque Art liberal, ou quelqu’un des Arts liberaux d’un maistre’.¹⁹⁸

The mentions of Garamont also raise the question of what exactly was the relationship between the young Guillaume I Le Bé and Claude Garamont during this period of apprenticeship. The *Le Bé Memorandum* records that Claude Garamont was apprenticed to the printer and punchcutter Antoine Augereau (c. 1500-1534), where he learnt type casting, mould-making, justifying and punchcutting. Auguste Bernard maintained that Garamont was an ‘élève de Geoffrey Tory’, but this assertion has been recently challenged and there appears to be no documentary proof to support the claim.¹⁹⁹ The possible dates for Garamont’s period of apprenticeship (c. 1525 – 1534) could coincide with the later years of Tory’s working life, as he was appointed Imprimeur du Roi in 1531 and is thought to have died about 1533.²⁰⁰ The connection to Tory would be the influence of his alphabets in *Champ Fleury*, published in 1529. It should also be noted that the Hebrew alphabet shown in *Champ Fleury*, while clearly Sephardic in origin, is much closer to some of the larger titling letters used in some of the Venetian Hebrew editions, yet are very crude in execution and display a basic misunderstanding of the termination strokes in Hebrew letters.²⁰¹ These are not the models used by Guillaume I Le Bé in any of his Hebrews, either early on or later in his career. It is more than likely that Le Bé would have known of these alphabets, just as he knew of the Ashkenazic Hebrew alphabets, but chose to follow quite different models in his own work.²⁰²

¹⁹⁷ *Journal des Sçavans*, Janvier 1756, p. 16, Septembre 1756, p. 588, *Mercur de France*, Mai 1756, p.125

¹⁹⁸ Randle Cotgrave, *A Dictionarie of the French and English tongues* (London: Adam Islip, 1611) and *Dictionnaire de l’Académie française*, 1st Edition (1694)

¹⁹⁹ Auguste Bernard, *Geofroy Tory, peintre et graveur, premier imprimeur royal, reformateur de l’orthographe et de la typographie sous Francois Ier* (Paris: Edwin Tross, 1857), pp. 47, 74, 89,200. I am grateful to Professor Hendrik Vervliet for his clarification on this point.

²⁰⁰ Stéphanie Deprouw and Musée national de la Renaissance (France), *Geoffroy Tory: imprimeur de François Ier, graphiste avant la lettre* (Paris: Réunion des musées nationaux: Grand Palais, 2011), pp. 108-121

²⁰¹ folios 68-69

²⁰² See page 87 for detailed discussion on calligraphic models used by Le Bé.

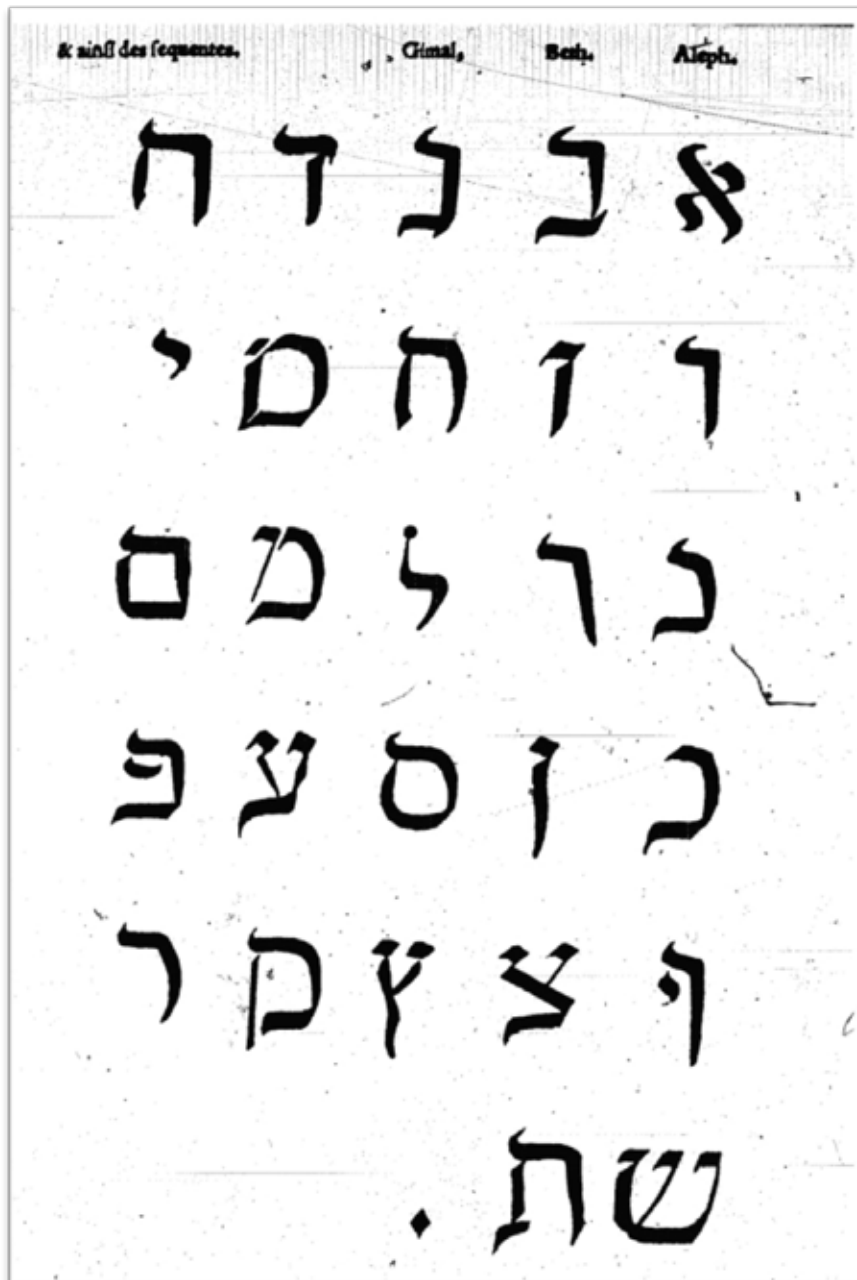

Fig. 2.2: Hebrew alphabet from Folio 68r of *Champ Fleury* Reduced in scale (From Gallica.fr f. 152)

Following a period as a journeyman from c. 1535 to 1538, Garamont worked as a master until his death in 1561, during which time he made and sold founts and had various apprentices as type-casters.²⁰³ There is no document recording a formal association with Guillaume I Le Bé.²⁰⁴ Yet we do know that Guillaume I Le Bé and Jean Le Sueur, both listed as type founders, compiled an inventory of the Garamont typefoundry in November 1561²⁰⁵ and that Guillaume I Le Bé acquired at least some

²⁰³ Vervliet, *French Renaissance Printing Types: A Conspectus*, pp. 39-40

²⁰⁴ Annie Parent and Jeanne Veyrin-Forrer, 'Claude Garamont: New Documents', *The Library*, s5-XXIX (1974)

²⁰⁵ Guilleminot-Chrétien, 'Le Testament de Claude Garamont', in *Le livre et l'historien: Etudes offertes en l'honneur du Professeur Henri-Jean Martin*, ed. by Martin and Barbier (Geneve: Librairie Droz, 1997), p. 136

of Garamont's punches and matrices following his death.²⁰⁶ Vervliet has written about this period of Guillaume I Le Bé's training that 'he must have known the ageing (Simone de) Colines or learned about his reputation during an apprenticeship in the 1540-50s at Robert I Estienne's and Claude Garamont's premises' and would lead one to conclude that the arrangement between Garamont and Le Bé was an informal one.²⁰⁷

Yet the professional links between Guillaume I Le Bé and Garamont are clearly attested in two accounts. The first is a passage from a manuscript now in the British Library and written by the orientalist Guillaume Postel about 1560 which notes that Robert Estienne acquired some of Garamont's Grecs du Roy – most probably the *Gros-romain* of 1543, the *Cicero* of 1546 and the *Gros-Parangon* of 1550. The earliest of these types would fall within the period of Le Bé's apprenticeship to Robert Estienne and thus it is more than likely that Le Bé's personal and professional acquaintance with Garamont dates from this period. The second account comes from the *Le Bé Memorandum* which recounts that Le Bé, 'estant de retour d'Italie à la fin de lan 1550 demeura vn an ou enuiron chez ledit Garamond en susditte maison de la boulle Ruë des Carmes ...'.²⁰⁸ This second comment is certainly evidence of a close professional and personal relationship.

The *Lettres Patentes* of Villiers- Cotterêts of the 31 August 1539 do not make mention of the distinction between *apprenti* and *alloué*. An *alloué* has been defined as 'an apprentice who would never qualify as a master'.²⁰⁹ The English equivalent would be a journeyman. This status was established legally in 1723, but might have existed more informally in earlier periods.²¹⁰ Nicholas Contat dit Le Brun describes these differences as they existed in the eighteenth centuries where there were recorded *brevets d'apprentissage* and *brevets d'allouage*.²¹¹ It is not known if Guillaume I Le Bé attained the status of journeyman or master, nor whether he presented a *chef d'oeuvre* upon completion of his apprenticeship.²¹²

²⁰⁶ This was claimed by Fournier l'aîné in his letter published in the *Mercure de France*, of May 1756. See Pierre-Simon Fournier and Jacques André, 'Lettres polémiques sur la typographie' (2009) <<http://jacques-andre.fr/ed/Lettres.pdf>> [Accessed 07 July 2011], p. 94. See also Louis Delacolonge and Harry Carter, *The type specimen of Delacolonge. Les caractères et les vignettes de la fonderie du sieur Delacolonge, Lyons, 1773. Introduction and notes by Harry Carter. (Facsimile ... made from a copy belonging to the publishers.)* (Amsterdam: Van Gendt & Co, 1969), pp. 32-33

²⁰⁷ H. D. L. Vervliet, *The Palaeotypography of the French Renaissance: Selected Papers on Sixteenth-Century Typefaces* (Leiden: Brill, 2008), p. 64 (Vol. 61)

²⁰⁸ See *ibid.*, pp. 104-148, 167-168 (Volume I) and Le Bé, *The Le Bé memorandum*, p. 18

²⁰⁹ Nicolas Contat and Giles Barber, *Anecdotes Typographiques* (Oxford: Oxford Bibliographical Society, 1980), p. 11

²¹⁰ Hauser records the use of the term 'alloué' in the sixteenth century. See Hauser, *Ouvriers du Temps Passé*, p. 39

²¹¹ Contat and Barber, *Anecdotes Typographiques*, pp. 12, 36-37

²¹² Renouard records one instances of a *maître-fondeur de lettres à imprimer* (Jean Girault) in 1567 and the same status for various other trades such as *parchemenier*, *imprimeur*, *libraire*, *cartier*, *doreur sur cuir*, *apothicaire* and *foureur de robes*. He also notes that 'les privilèges qui permettaient aux fils et aux gendres de maîtres d'obtenir la maîtrise sans formalités les engageaient à conserver la profession de leurs pères, et nous retrouvons les mêmes familles exerçant les mêmes

The edict also issued at Villiers-Cotterêts on the 25th August 1539 – which established in clause 111 the use of French in place of Latin in all state and legal documents – also makes mention in clause 190 of a *chef d'oeuvre* in the following terms: 'lequel toutesfois nous déclarons inhabile et incapable de la maistrise, *au cas qu'il auroit fait autre despense que celle de son chef-d'oeuvre pour parvenir à ladite maistrise*, (my italics) et l'en voulons estre privé et débouté par nos juges ordinaires des lieux ausquel la cognoissance en appartient'. This implies that it was not a common practice and that other types of certification were generally accepted.²¹³ Giles Barber has noted that 'in the sixteenth-century printers appear to have been generally free in being allowed to take on apprentices although the academic standard required of candidates appears to have risen progressively', a point which relates to the increasing regulation of apprenticeships in the seventeenth century.²¹⁴

It thus seems likely that Guillaume I Le Bé entered the printing establishment of Robert I Estienne as an apprentice or 'student' in either 1539 or 1540 at the age of 14 or 15 years of age. The *Le Bé Memorandum* also notes that he was a contemporary of 'Iehan picard' (Jean Picard) and 'Mathieu Poignet'. Harry Carter in his notes comments that 'Poignet became a typesetter and that P. Picard, a good punchcutter, went to England and died there'.²¹⁵ The P. Picard mentioned in the *Journal des Sçavants* in the February 1756 issue appears to be an incorrect attribution and the reference is in fact to Jehan (Jean) Arnould, dit Picard, le Jeune, Arnould (or Arnoul) to whom is ascribed several Hebrews in his name in the Le Bé documents. Vervliet maintains that Arnoul acted as an instructor to Guillaume I Le Bé and in fact travelled with him as far as Lyons, where he died.²¹⁶ The reason for their trip may have been to seek work in Lyons, then the second printing centre in France.²¹⁷ Arnoul's death and the effects of ongoing conflicts between master printers and workers might have encouraged Le Bé to continue on to Venice, leaving aside the question for the moment whether he had in fact been invited by Giustiniani. These conflicts and strikes had the result, according to Hauser, of closing down almost completely work in the typographic workshops from the spring of 1539 to the end of 1542.²¹⁸

Robert I Estienne was the second of the Estienne dynasty, and took over from his father Henri in about 1526. He printed in Paris until 1550, when he moved to Geneva. His Genevan imprints run from 1551 until his death in 1559. His first

professions pendant de nombreuses générations. See Renouard, *Documents sur les imprimeurs, libraires, cartiers, graveurs, fondeurs de lettres*, p. VI

²¹³ See 'Ordonnance d'août 1539 ou ordonnance de Villiers-Cotterêts' (<<http://www.assemblee-nationale.fr/histoire/villiers-cotterets.asp>> [Accessed 22 March 2012]

²¹⁴ Contat and Barber, *Anecdotes Typographiques*, p. 10

²¹⁵ Le Bé, *The Le Bé memorandum*, p. 48 (Note 48)

²¹⁶ Vervliet, *French Renaissance Printing Types: A Conspectus*, pp. 41-42

²¹⁷ See Delacolonge and Carter, *The type specimen of Delacolonge*, p. 13

²¹⁸ Hauser, *Ouvriers du Temps Passé*, p. 178 (ces conflits, qui agita l'imprimerie parisienne et lyonnaise, de 1539 à 1572, et d'abord la grève qui suspendit presque complètement le travail dans les ateliers typographiques des deux grandes villes depuis le printemps de 1539 jusqu'à la fin de 1542.)

Hebrew imprint dates from 1527 and, during his lifetime, he issued nearly 75 separate editions, depending how one counts reissues, amended editions and reimpressions.²¹⁹

The scholarly and open-minded atmosphere of the Estienne household is well-documented and could well have had an impact on the young Le Bé. Although there is no evidence that Estienne had any connections to the Family of Love, as did Plantin later on in Antwerp, he had a 'strong commitment to Calvinism' and the exposure to such unconventional influences could certainly have influenced Le Bé's attitude to Jews and Protestants with whom he later came into contact. The Latin poem composed by John Dorat in 1538 and based on the visit by the scholar Junius Rabinus to Estienne's press and household gives a fulsome description of the ambiance of 'civil learning' and 'purity of Latin speech' which the young Le Bé would have encountered during his period there.²²⁰

Robert Estienne received the title of *imprimeur et libraire du Roi en lettres hebraïques et latines* in a letter issued by François I^{er} in June 1539, although there is an earlier document from January of that year which allows him '100 ecus par an, sur la recette d'Outre-Seine et Yonne, les gagtes de Robert Estienne, imprimeur de lettres latines et hebraïques'.²²¹ He does not appear to have used this title much earlier than 1540, when at least three editions (not Hebrew) were signed as 'Parisiis apud (or ex officina) Robertum Stephanum, Hebraicarum & Latinarum literarum typographum regium' or 'Paris, de l'imprimerie de Robert Estienne, Imprimeur du Roy en hebreu et latin'.²²² His earliest Hebrew was probably cut by himself, a hypothesis supported by Vervliet based on the note in the Le Bé Memorandum, which recounts that Estienne 'se mit à faire et faire faire des caracteres hebreux dont il imprima la Bible en 4^o et commença par quelques volumes qui se vendirent à part...'. This most probably refers to the quarto Bible printed in 1528. Vervliet identifies this Hebrew as a 2 mm Saint-Augustin. A second Hebrew, also a Saint-Augustin of 2.2 mm appeared in 1532 for which no punchcutter is known.²²³

²¹⁹ The first comprehensive listing of the Estienne editions is that of Antoine Augustin Renouard, *Annales de l'Imprimerie des Estienne, ou, Histoire de la Famille des Estienne et de ses éditions* (Paris: Jules Renouard & Cie, 1837). This work is not accurate in many respects and is not a useful guide for the Hebrew editions. The more recent work by Lyse Schwarzfuchs is much more accurate and lists the Hebrew editions individually and separately. See Schwarzfuchs and Coron, *Le livre hébreu à Paris au XVI^e siècle*

²²⁰ See Paul Binding, *Imagined corners: exploring the world's first atlas* (London: Review, 2003), pp. 60-61 and Elizabeth Armstrong, *Robert Estienne: Royal Printer* (Cambridge: Cambridge University Press, 1954), pp. 58-61. See also the notes in the revised 1986 edition of Armstrong, *Robert Estienne royal printer: an historical study of the elder Stephanus*, pp. 291-292

²²¹ *Catalogue des Actes de François I^{er} 1515-1547*. Gallica.fr (Paris: Imprimerie Nationale, 1905), pp. 32840 (Vol. VIII), 21944 (Vol. VI)

²²² Renouard, *Annales de l'Imprimerie des Estienne*, p. 50. See also Armstrong, *Robert Estienne: Royal Printer*, pp. 117-123

²²³ See Vervliet, *French Renaissance Printing Types: A Conspectus*, pp. 136-138 (Volume I) and Le Bé, *The Le Bé memorandum*, p. 16

There is yet another intriguing but as yet unsolved reference to Le Bé's early Hebrews while he was apprenticed to Robert I Estienne. The 1950 edition of the *Cabinet des Poinçons de l'Imprimerie Nationale* refers to four existing founts of Hebrew. The first two, 6 point and 8 point are described as 'un des plus anciens qui existent & des plus célèbres ... il a été gravé par Guillaume Le Bé sous la direction de Robert Estienne & sur les propositions de Guillaume Budé, Bibliothécaire du roi François I^{er} à Fontainebleau'. The second two – the 14 point and the 17 point, were engraved respectively by Marcellin Legrand in 1836 and Bertrand Loeulliet in 1858.²²⁴ The caption to the 8 point notes that this was re-engraved by Aubert in 1881. A later edition (1990) contradicts this assertion somewhat and maintains that it 'a été gravé par Aubert en 1879 ... il reproduit le type créé par Guillaume Le Bé, avec lequel Robert Estienne publia sa Bible'.²²⁵

The inventories of the Cabinet des Poinçons confirm that the engravers were in fact Aubert (for the 6 and 8 point Hebrews) and Marcellin-Legrand for the 14 point and Loeulliet for the 17 point. There is indeed a set of stepped punches for an 8 point Hebrew in the Cabinet des Poinçons, but the assertion that they are the work of Guillaume I Le Bé during his period with Robert Estienne cannot be verified except on stylistic grounds.²²⁶ The mention of Guillaume Budé is of interest as he was a close friend of Robert I Estienne, who had published Budé's *Commentarii linguæ graecae* in 1548. Budé was also the main inspiration behind the *Collège des Trois Langues* (Collegium Trilingue), which was founded in 1530 and included Hebrew among its subjects, so it is possible that he could have had a say in the creation of the new Hebrew typeface.²²⁷

²²⁴ L'Imprimerie Nationale, *Cabinet des poinçons de l'Imprimerie Nationale*. Vol. 2. Ed (Paris L'Imprimerie Nationale, 1950), p. XXX See also James Mosley, *A Dictionary of Punchcutters for Printing Types (Unpublished)* (London, 1999)

²²⁵ L'Imprimerie Nationale, *Les caractères de l'Imprimerie Nationale* (Paris L'Imprimerie Nationale, 1990), p. 167, Mosley, *A Dictionary of Punchcutters for Printing Types*, *ibid.*

²²⁶ I am grateful to Madame Nelly Gable of the Cabinet des Poinçons in Ivry for allowing me to see these punches and also for the references from the Cabinet des Poinçons Inventaires from December 1903.

²²⁷ Eugene de Budé, *Vie de Guillaume Bude fondateur du collège de France (1467-1540)* (Paris: Librairie Académique Didier Emile Perrin, Libraire-Editeur, 1884), Mosley, *A Dictionary of Punchcutters for Printing Types*

בראשית ברא אלהים את השמים ואת הארץ : והארץ היתה תהו ובהו וחשך על־פני תהום ורוח אלהים מרחפת על־פני המים : ויאמר אלהים יהי־אור ויהי־אור : וירא אלהים את־האור כי־טוב ויבדל אלהים בין האור ובין החשך : ויקרא אלהים לאור יום ולחשך קרא לילה ויהי־ערב ויהי־בקר יום אחד : ויאמר אלהים יהי רקיע בתוך המים ויהי מבדיל בין מים למים : ויעש אלהים את־הרקיע ויבדל בין המים אשר מתחת לרקיע ובין המים אשר מעל לרקיע ויהי־כן : ויקרא אלהים לרקיע שמים ויהי־ערב ויהי־בקר יום שני : ויאמר אלהים יקוו המים מתחת השמים אל־מקום אחד ותראה חיבשה ויהי־כן : ויקרא אלהים ליבשה ארץ ולמקוה המים קרא ימים וירא אלהים כי־טוב : ויאמר אלהים תדשא הארץ דשא עשב מזריע זרע עץ פרי עשה פרי למינו אשר זרעו־בו על־הארץ ויהי־כן : ותוצא הארץ דשא עשב מזריע זרע למינהו ועץ עשה־פרי אשר זרעו־בו למינהו וירא אלהים כי־טוב : ויהי־ערב ויהי־בקר יום שלישי : ויאמר אלהים יהי מארת ברקיע השמים להבדיל בין היום ובין הלילה והיו לאתת ולמועדים ולימים ושנים : והיו למאורת ברקיע השמים להאיר על־הארץ ויהי־כן : ויעש אלהים את־שני המארת הגדלים את־המאור הגדל למטשלת היום ואת־המאור הקטן למטשלת הלילה ואת הכוכבים : ויתן אתם אלהים ברקיע השמים להאיר על־הארץ : ולמטש ביום ובלילה ולהבדיל בין האור ובין החשך וירא אלהים כי־טוב : ויהי־ערב ויהי־בקר יום רביעי : ויאמר אלהים ישרצו המים שרץ נפש חיה ועוף יעופף על־הארץ על־פני רקיע השמים : ויברא אלהים את־התנינם הגדלים ואת כל־נפש החיה הרמשת אשר שרצו המים למינהם ואת כל־עוף כנף למינהו וירא אלהים כי־טוב : ויברך אתם אלהים לאמר פרו ורבו ומלאו את־המים בימים והעוף ירב בארץ : ויהי־ערב ויהי־בקר יום חמישי : ויאמר אלהים תוצא הארץ נפש חיה למינה בהמה וחיית־ארץ למינה ויהי־כן : ויעש אלהים את־חית הארץ למינה ואת־הבהמה למינה ואת כל־רמש האדמה למינהו וירא אלהים כי־טוב : ויאמר אלהים נעשה אדם בצלמנו כדמותנו וירדו בדגת הים ובעוף השמים ובבהמה ובכל־הארץ ובכל־הרמש הרמש על־הארץ : ויברא אלהים את־האדם בצלם אלהים ברא אתו זכר ונקבה ברא אתם : ויברך אתם אלהים ויאמר להם אלהים פרו ורבו ומלאו את־הארץ וכבשה ורדו בדגת הים ובעוף השמים ובכל־חיה הרמשת על־הארץ : ויאמר אלהים הנה נתתי לכם את־כל־עשב זרע זרע אשר על־פני כל־הארץ ואת־כל־העץ אשר־בו פרי־עץ זרע זרע לכם יהיה לאכלה : ולכל־חית הארץ ולכל־עוף השמים ולכל רמש על־הארץ אשר־בו נפש חיה את־כל־ירק עשב לאכלה ויהי־כן : וירא אלהים את־כל־אשר עשה והנה־טוב טוב מאד ויהי־ערב ויהי־בקר יום השישי : ויכלו השמים והארץ וכל־צבאם : ויכל אלהים ביום השביעי מלאכתו אשר עשה וישבת ביום השביעי מכל־מלאכתו אשר עשה : ויברך אלהים את־יום השביעי ויקדש אתו כי בו שבת מכל־מלאכתו אשר־ברא אלהים לעשות

Fig. 2.3: Corps 6 from the *Cabinet des Poinçons de l'Imprimerie Nationale*, 1950 (Actual size)

אבגדהוזחטיכךלמססנזעפףצץקרשת:

Fig. 2.4: Partially Assembled alphabet of the corps 6 Hébreu Actual Size (x = 2.0 mm) Imprimerie Nationale

אבגדהוזחטיכךלמססנזעפףצץקרשת:

Fig. 2.5: Corps 6 Hébreu Enlarged x1.5 Imprimerie Nationale

אבגדהוזחטיכךלמססנזעפףצץקרשתא

Fig. 2.6: Hb1 (S) The first Le Bé Square Sephardic as a comparison

אנכי יהוה אלהיך אשר הוצאתיך מארץ מצרים מכית עבדים :
 לא יהיה לך אלהים אחרים על פני :
 לא תעשה לך פסל וכל תמונה אשר בשמים ממעל ואשר בארץ
 מתחת ואשר במים מתחת לארץ : לא תשתחוה להם ולא תעבדם
 כי אנכי יהוה אלהיך אל קנא פקד עון אבת על בנים על שלשים
 ועל רבעים לשנאי : ועשה חסד לאלפים לאהבי ולשמרי מצותי :
 לא תשא את שם יהוה אלהיך לשוא כי לא ינקה יהוה את אשר
 ישא את שמו לשוא :
 זכר את יום השבת לקדשו : ששת ימים תעבד ועשית כל מלאכתך :
 ויום השביעי שבת ליהוה אלהיך לא תעשה כל מלאכה אתה
 ובנך ובתך עבדך ואמתך ובהמתך וגרך אשר בשעריך : כי ששת
 ימים עשה יהוה את השמים ואת הארץ את הים ואת כל אשר
 בם וינח ביום השביעי על כן ברך יהוה את יום השבת ויקדשהו :
 כבד את אביך ואת אמך למען יארכון ימיך על האדמה אשר
 יהוה אלהיך נתן לך :
 לא תרצה :
 לא תנאף :
 לא תגנב :

Fig. 2.7: Specimen of the Corps 8 from the *Cabinet des Poinçons de l'Imprimerie Nationale*, 1950 (Actual size)

אבגדהוזהיכךלמסננסעפףצץקרשת:

Fig. 2.8: Partially assembled alphabet of the Corps 8 from the *Cabinet des Poinçons de l'Imprimerie Nationale*, 1950 (Actual size)

A comparison of the Imprimerie Nationale Corps 6 and the Corps 8 to the first Le Bé Square Sephardic – Hb1 (S) – shows a similar treatment for certain characters, the aleph (א), the lamed, the peh (פ), the tsadde (צ) and the shin, yet with clear differences in the tet, the ayin (ע), and the tav (ת). If some of the original Le Bé punches were reworked indeed by Aubert in the nineteenth century, this would account for at least some of the differences.

The same entry on Robert Estienne in the *Le Bé Memorandum* continues with the following passage:

Neamoins lesdits caracteres ne se trouuerent pas si agreables qu lon eseroit, Et cest *ce gros vilain hebreu* (my italics) dont sont imprimez quelques liures,

comme Ieremie, Esaïe, Iob, et autres prophetes, de sorte quil fit Reffaire lesdits Caracteres hebrieux de la bible in 4^o par un nommé Jehan picard homme le plus adroit a la proportion & grace des Caracteres quil fut en ce templa, mon père estoit alors apprentif chez ledit Estienne en 1542, *et il trauailla sur la fin auxdits caracteres*, (my italics) et se sont Rencontrés Les plus beaux, et aussy toute la bible en fut imprimée qui est celle qui se voit apresant'²²⁸

This comment raises as many questions as it answers, before attempting a hypothesis as to which types Le Bé worked on, several questions need to be examined:

- Which Hebrew typefaces were in use and were used for these editions. Which typeface is in fact this 'ce gros vilain hebreu' and which were cut by Jehan Arnoul?
- Which editions were published during the period of Le Bé's apprenticeship to Robert Estienne?

In his two seminal publications Hendrik Vervliet has identified ten Hebrew types in use by Robert I Estienne during his periods of activity in Paris and Geneva. The types are ordered by approximate date and not by size.²²⁹

1. The first 'Estienne' Square Sephardic Hebrew on English or *Saint-Augustin* (1527-28). Punchcutter: Vervliet's contention is that this was cut by Robert I Estienne himself. See *Conspectus* no. 372 or Hb 2.
2. The second 'Estienne' Square Sephardic Hebrew on English or *Saint-Augustin* (1532). Punchcutter: Unknown. See *Conspectus* no. 374 or Hb 2.2.
3. The first 'Estienne' Square Sephardic Hebrew on Two-line Pica or *Gros-Parangon* (1539). Punchcutter: Vervliet identifies this type as the *gros vilain hebreu* and his hypothesis is that it was cut by Michel du Boys. See *Conspectus* no. 395 or Hb 4.
4. The 'Estienne' Rabbinical Hebrew on English or *Saint-Augustin* (1539). Punchcutter: Unknown - according to 1665 f. 4 this gloss is not attributed to Jean Arnoul le Picard. See Hb31 (R) in this thesis and *Conspectus* 377 or Hb2.
5. The third 'Estienne' Square Sephardic Hebrew on English or *Saint-Augustin* (1539). Punchcutter: Unknown - Vervliet's hypothesis is that this might have been cut by Michel du Boys. See *Conspectus* no. 376 or Hb 2.44.

²²⁸ Le Bé, *The Le Bé memorandum*, pp. 16-17. Carter's translation reads: The type proved not to be as agreeable as was hoped: it was the big ugly Hebrew with which some of the Books, Jeremiah, Isaiah, Job, and other prophets were printed; so he had new faces cut for the 4to Bible by a man named Jehan Picard, who was at that time the most skilled in the proportions and grace of printer's letters. My father was apprentice (*sic*) to Robert Estienne, that is to say in 1542, and he worked at these letters towards the end. (pp. 28-29)

²²⁹ Vervliet, *The Palaeotypography of the French Renaissance: Selected Papers on Sixteenth-Century Typefaces*, pp. 136-146 (Vol. I) See also Vervliet, *French Renaissance Printing Types: A Conspectus*

6. Picard's Square Sephardic Hebrew on Two-Line Great Primer *Petit-canon* or *Trimégiste* (1543). Punchcutter: Jean Arnoul le Picard. See Hb27 (S) in this thesis and *Conspectus* 399 or Hb6.
7. Picard's Square Sephardic Hebrew on Two-Line Pica *Gros-Parangon* or *Palestine* (1543). Punchcutter: Jean Arnoul le Picard. See Hb28 (S) in this thesis and *Conspectus* 396 or Hb 4.
8. Picard's Square Sephardic Hebrew on Great Primer or *Gros-Romain* or *Saint-Augustin* (1543). Punchcutter: Jean Arnoul le Picard. See Hb29 (S) in this thesis or *Conspectus* 378 or Hb 2.2.
9. Picard's First Square Sephardic Hebrew on English or *Saint-Augustin/Cicéro* (1543). Punchcutter: Jean Arnoul le Picard. See Hb30 (S) in this thesis or *Conspectus* 369 or Hb 1.8.
10. The 'Estienne' Rabbinical Hebrew on Brevier or *Petit-texte* (1556).
Punchcutter: Pierre Haultin? This type appears to have been used only in the Genevan imprints and the x-height is 1.2 mm.

The types which are relevant to the question of Guillaume I Le Bé's involvement in the cutting of the Estienne Hebrews are number three (the 'gros vilain hebreu') which can be possibly be attributed to Michel du Boys and the number seven, which is firmly attributed to punchcutter Jean Arnoul.²³⁰ An examination of these two assembled alphabets shown on page 80 as compared to Le Bé's first Hebrew – Hb1(S) – leads to the tentative conclusion that Le Bé assisted in the cutting of fount number seven, as the Arnoul fount is generally closer in most respects to the attributed Le Bé founts. The key recognition characters in this context would be the gimmel, the zayin (ז), and the tsadde. The shin in the Arnoul fount has the termination on the middle stroke pointing right, a feature used consistently by Le Bé. The shin on the *gros vilain hebreu* has the termination on the same stroke pointing left, *not* a characteristic of Le Bé's Hebrews. The treatment of the lamed in both founts is quite similar and decidedly different to the way Le Bé dealt with this character in his own cuttings. It has to be said that Le Bé's skill as punchcutter and his sensitivity to historic Hebrew letterforms models is very striking from the very outset of his career, and that these qualities are not clearly visible in the two Estienne founts. Can it truthfully be said that the Estienne number 3 is *vilain*, meaning not necessary ugly, but crude or unsightly? It is certainly closer to a Hebrew scribal models, if one notes the angled base of the bet and the curved right hand stroke of the tet, but still heavy and cumbersome in appearance when compared to Le Bé's later productions.

The decisive factor which ought to lead one to conclude that Le Bé had a hand in the Arnoul fount is the date. Vervliet has dated these founts to 1543, whereas the 'gros

²³⁰ H. D. L. Vervliet, 'Robert Estienne's Printing Types', in *The Palaeotypography of the French Renaissance: Selected Papers on Sixteenth-Century Typefaces* (Leiden and Boston: Brill, 20048), p. 139.

vilain hebreu' is dated to 1539, the period when Le Bé began his apprenticeship with Estienne, and thus it is highly improbable that he could have taken part in cutting these punches so early in his apprenticeship. Furthermore the comment in the *Le Bé Memorandum* uses the phrase '*sur la fin auxdits caracteres*', and this can most probably be taken to mean at the end of his apprenticeship.²³¹ It should be noted that Le Bé's annotation in Rés X 1665, folio 4 dates the four Estienne Hebrews cut by Arnoul to the year 1541, which would also support the assertion that he took part in some way in the cutting of these founts.

And yet if we accept that Le Bé had a hand in the Arnoul Estienne founts, we are left in any case with the hypothesis that Le Bé worked under the guidance and instruction of Arnoul. It was only *after* his exposure to alternative Hebrew letterform models in Venice, that he was able to arrive at his own style and handling, which stayed quite constant throughout his career as a punchcutter. The exposure to Sephardic scribal Hebrew hands, which Le Bé may have seen in Robert Estienne's workshop in Paris and most certainly saw in Venice, must have influenced his perception of the way that a Hebrew typeface should appear.

This attribution is confused when one notes that *both* these founts have been used in *similarly* dated editions. For example, the British Library copy of Jonah (Ionas) which is dated 1540, is clearly a different impression from the copy in the Bibliothèque nationale de France (Rés-4-NFA-3) which is *also* dated 1540. Yet the British Library copy (1942.g.2) uses the first 'Estienne' Square Sephardic Hebrew on Two-line Pica (the *gros vilain hebreu*), whereas the Bibliothèque nationale de France copy (Rés-4-NFA 3) uses Picard's Square Sephardic Hebrew on Two-Line Pica (Hb 4 mm) *Gros-Parangon* or *Palestine*. Randall McCleod has noted that in Jonah the same two different founts can also be seen on the title page of Haggai (Aggaeus) in two different copies from the Bibliothèque Mazarine and the Fisher Rare Book Library in Toronto.²³²

McCleod's explanation is that these editions 'ont fait l'objet de réédition attribuées à Robert Estienne avant 1550, l'année de son départ pour Genève'. Furthermore McCleod argues that Estienne had underestimated the market demand for these volumes and thus was obliged to reprint them and did so without changing the date. This explanation would allow us to account for the use of the two different founts, one dating from 1539 and the other from 1543.²³³

This hypothesis is supported by Vervliet, who writes that 'some of the earlier instalments of the quarto Bible were reissued in or after 1543 possibly even in or after 1549; they were completed recomposed but maintained the original date of publication'. He adds that 'these antedated reissues area are recognizable by their use

²³¹ Le Bé, *The Le Bé memorandum*, p. 17

²³² Randall McCleod, 'ALTVM SAPERE: Parole d'homme et Verbe divin. Les chronologies de la Bible hébraïque in-4° de Robert Estienne', in *La Bible imprimée dans l'Europe moderne (XVe-XVIIIe siècle)*, ed. by Bertram Schwarzbach (Paris: Bibliothèque nationale de France, 1999), pp. 123-129

²³³ *Ibid.*, p. 129

of the new Picard Hebrews'. Vervliet notes that the 'big ugly Hebrew' was only used by Robert I Estienne and suggests that it might have been cut by the punchcutter Michel du Bois, given his period of activity in Paris (up to 1538) and his later association with Le Bé in Venice in the cutting of Hb23 (S).²³⁴



Fig. 2.9: The two alternate Hebrews used in the Estienne editions (Enlarged to common size)

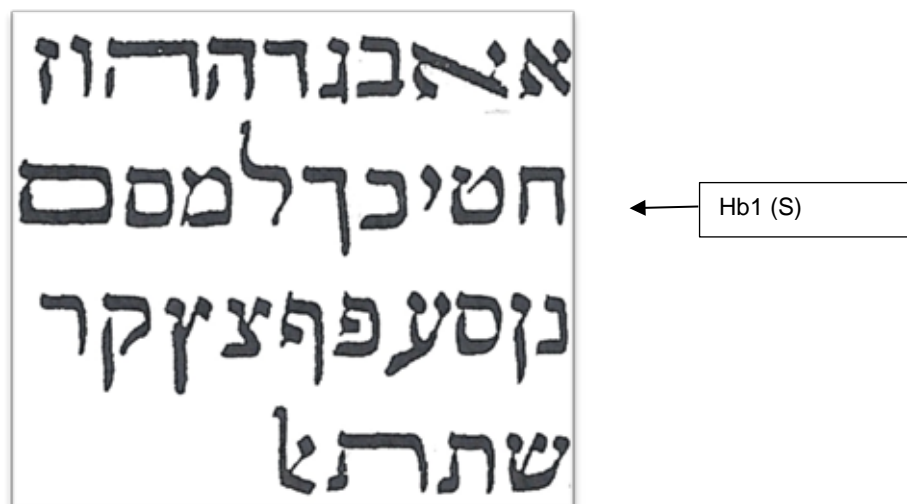

Fig. 2.10: Hb1(S): Assembled alphabet enlarged view to approx. 7 mm x-height as a comparison

²³⁴ Vervliet, 'Chapter 3', in *The Palaeotypography of the French Renaissance: Selected Papers on Sixteenth-Century Typefaces* (Leiden and Boston: Brill, 20048), p. 139. See Rodolphe Peter, 'Un Imprimeur de Calvin: Michel du Bois', *Bulletin de la Société d'histoire et d'archéologie de Genève*, 16 (1978), *ibid.* See also page 228 in this thesis.

The Hebrew Bible published by Estienne during the years 1539 to 1544 appeared in 24 sections in a quarto format. Subsequently he issued a 16mo edition in 17 sections during the period 1543 to 1546. The Estienne catalogue of 1546, presumably issued for the Frankfort fair, under the heading *Biblia mediocri forma* (or the quarto edition) lists the following contents listed as separate items for sale: Genesis, Exodus, Deuteronomium, Leviticus, Numeri, Prophetae priores (Iosue, Iudicum liber, Samuel), Regum libri duo, Liber Paralipomenon, Isdras, Iob, Psalterium, Proverbia Salomonis, (Canticum canticorum, Ruth, Lamentationes Ieremiae, Ecclesiastes, Esther), Esaias, Ieremias, Ezechiel, Daniel, Duodecim Prophetae (Osee, Ioel, Amos, Abdias, Ionas, Michaeas, Nahum, Habacuc, Sophonias, Haggaeus, Zacharias, and Malachias).²³⁵

The subsequent heading in the catalogue is for the *Biblia enchiridia forma*, or the 16mo edition, which consists of Genesis, Exodus, Leviticus, Numeri, Deuteronomium, Iosue & Iudicum liber, Psalterium, Proverbia Salomonis, Esaias, Ieremias, Ezechiel, Daniel & Esdras, and the Prophetae minores duodecim. The entire quarto Bible could be purchased in its entirety at that time for 100 sous, whereas purchasing the separate instalments was more costly. The 16mo edition could only be bought as separate sections.²³⁶

The Hebrew editions printed during the probable period of Guillaume Le Bé's apprenticeship were examined, based on the editions listed in the Renouard bibliography and the Schwarzfuchs chronological inventory.²³⁷ The listing in Appendix I sets out the founts used in each edition as far as could be determined. The provisional conclusion from this data is that the first 'Estienne' Square Sephardic Hebrew on Two-line Pica was used from 1539 until about 1543, when Picard's Square Sephardic Hebrew on Two-Line Pica began to be used in its place. The 16mo Hebrew Bible which was begun in January 1544 uses mainly, but not consistently, the Picard fount. This would fit in with the last year of Le Bé's apprenticeship.²³⁸ This would support the hypothesis that Guillaume I Le Bé assisted in the cutting of the Arnoul founts during the later years of his apprenticeship to Robert Estienne.

The *Le Bé Memorandum* places the date of Le Bé's completion of his apprenticeship 'vers le mois d'octobre 1545' when he left Paris and notes that he 'fut demeurer à

²³⁵ See Appendix L on page 598 for a comparative list of Biblical names.

²³⁶ Randal McLeod notes that 28 installments ('fascicules') were issued and that the order corresponded neither to the canonical order according to the Catholic Church nor to the Jewish tradition. He writes that 'il y avait treize fascicules avec pages de titres, plus celles de onze des douze constituants du *Duodecim Prophetae*. Seul Osias, le premier, n'avait pas d'autre page de titre que celle de la série' Ceci fait donc quatre fascicules de plus que le classique vingt-quatre livres, et ces pages de titre prétendent s'échelonner entre 1538 et 1544.' See McLeod, 'ALTVM SAPERE', in *La Bible imprimée dans l'Europe moderne (XVe-XVIIIe siècle)*, ed. by Schwarzbach (Paris: Bibliothèque nationale de France, 1999), pp. 86-88. See also Renouard, *Annales de l'Imprimerie des Estienne*, pp. 93-96

²³⁷ See Renouard, *Annales de l'Imprimerie des Estienne* and Schwarzfuchs and Coron, *Le livre hébreu à Paris au XVIIe siècle*. See also Appendix I on page 563.

²³⁸ The copy of Ezra for example, in Lambeth Palace Library (E15 1543), uses the first 'Estienne' Square Sephardic Hebrew on Two-line Pica and not the Picard.

Venise premierement'.²³⁹ Vervliet's hypothesis is that both Le Bé and Jean Arnoul left Paris together and arrived first in Lyons, where Arnoul died in 1545 'and Le Bé pursued his journey alone to Italy'.²⁴⁰ This would have been a logical route to take if they were headed for Venice as their ultimate goal, as opposed to the great overland Alpine routes such as Mont-Cenis, Simplon, St. Gotthard, Brenner and Tarvis.²⁴¹ It may also be that they envisaged finding work in Lyons, the second major French printing centre, as already has been suggested. The river route of the Rhône would have led to the French Mediterranean ports and thence by sea to Venice.

There is no documentary or even secondary evidence to suggest why Le Bé went to Venice. The annotations in NAF. 4528 f.1 would indicate that that he found work very quickly with Marco Antonio Giustiniani, and this would argue for some kind of previous connection or perhaps a personal invitation. There is also the possibility that this trip came about through Robert Estienne's printing connections.

There is evidence that there *was* an active trade in type between France and Italy during this period. Paolo Manuzio (Paulus Manutius 1512-1574), the third son of the founder of the Aldine Press, Aldus Manutius the Elder, wrote a letter in 1558 in which he describes a type specimen of three founts for editions of the Accademia Veneziana or the Accademia della Fama. He notes that 'il mezzano (quarto) ho fatto venir di Franza' and adds that 'e sono tutti i più eccellenti nel suo genere'. Renouard, who first published this letter, commented that 'c'est donc avec nos caractères françois de Garamond, que Paul Manuce a fait plusieurs de ses belles éditions in 4to, tant pour l'académie que pour son compte personnel'. Whether this attribution is correct is open to question, but what *is* of interest is the fact that Paolo Manuzio maintained that he had bought or ordered them from France, whether they were cast type, punches or matrices.²⁴² This is of course a later date than Le Bé's arrival in Venice, but it does demonstrate that there were established connections between Venetian and Parisian printers and punchcutters.²⁴³ Many of the typefaces shown in the 1628 type specimen of the Vatican Press show these connections. Vervliet has characterised the period in Italy from about 1530 to 1580 as one 'where new types were brought in from abroad, to small extent from Germany ... and to a large extent from France, whose letter-cutters and types had a great attraction for Italian

²³⁹ Le Bé, *The Le Bé memorandum*, p. 21

²⁴⁰ Vervliet, *French Renaissance Printing Types: A Conspectus*, p. 42

²⁴¹ See Fernand Braudel and Sian Reynolds, *The Mediterranean and the Mediterranean world in the age of Philip II* (London: Fontana Press, 1973), pp. 206-214 (Chapter III) for a discussion of trade routes during the sixteenth century.

²⁴² See Vervliet, 'Printing Types of Pierre Haultin: c. 1510-1587', in *The Palaeotypography of the French Renaissance: Selected Papers on Sixteenth-Century Typefaces* (Leiden: Brill, 2008), p. 257. Vervliet attributes at least one of the types mentioned by Manutius to Pierre Haultin's Second Pica Roman and suggests that 'Haultin sold them while staying in Lyons, using the traditional commercial ties of that city with Italy'.

²⁴³ Ant Aug Renouard, *Annales de l'Imprimerie des Alde* (Paris: Jules Renouard, Libraire, 1834), p. 270. See also A. F. Johnson, 'Some types used by Paolo Manuzio', *The Library*, s4-XIX (2) (1938), *ibid.*

printers, especially after 1550'.²⁴⁴ Included in these specimens are three by Le Bé, the *Canon Gros Roman* and his small capitals (both Roman and Greek), of which he records as having sold matrices to Lorenzo Torrentino in Florence and Tomaso Giunta in Venice.²⁴⁵ Although these Roman and Greek founts which Le Bé cut during his period in Venice were small in number as compared to his Hebrew founts, they point to his advanced skills as a punchcutter and the type of market which he serviced.

These facts also argue for some kind of invitation given to Le Bé by perhaps Marco Antonio Giustiniani to come to Venice and cut a new distinctive typeface to be used in his Hebrew editions, which began to appear in 1545. Ellic Howe agreed with this hypothesis, but did not provide any concrete proof for it.²⁴⁶ At a later period in 1578, the noted French punchcutter Robert Granjon was invited to come to Rome and produce type for the *Tipografia Medicea Orientale*, where he was paid a monthly salary of 20 Scudi and produced a wide variety of types, including a Great Primer Hebrew in 1585. Granjon's lifetime (c. 1513 to 1590) paralleled that of Le Bé, yet he appears to have been far more productive in the number of typefaces attributed to him – some ninety in total – and sold matrices 'to the whole of Europe'. His reputation would have preceded him prior to his arrival in Italy, but he serves as model for the international connections that a talented punchcutter would have developed in the sixteenth century.²⁴⁷

²⁴⁴ Andrea Brogiotti and Hendrik D. L. Vervliet, *The type specimen of the Vatican Press 1628* (Amsterdam: Menno Hertzberger, 1967), p. 24

²⁴⁵ See page 439 of this thesis, NAF 4528, folio 20.

²⁴⁶ Howe, 'The Le Bé Family', p. 3. See also Vervliet, 'Printing Types of Pierre Haultin: c. 1510-1587', in *The Palaeotypography of the French Renaissance: Selected Papers on Sixteenth-Century Typefaces* (Leiden: Brill, 2008)

²⁴⁷ Alberto Tinto, 'Per una storia della tipografia orientale a Roman nell'Età dell'Controriforma', *Accademie e Biblioteche d'Italia*, XLI (1973), p. 282. See also Vervliet, *French Renaissance Printing Types: A Conspectus*, pp. 43-44

Hb1 (S)

Appears on NAF 4528 folio 1 and Rés X 1665 folio 11
Type Classification: Square Sephardic unpointed
Type size/name: Texte (du Talmuth)
Measurements x-height of 2.7mm; 10 lines = 52 mm
Date and place of creation: 1545 in Venice (Le Bé's first numbered type)
Punchcutter: Guillaume I Le Bé
First occurrence: *Sefer Agur*, Giustiniani, Venice 1546?

The first specimen in NAF 4528, on folio 1, contains three elements. The first and third are a Rashi script – Hb2(R) – and will be discussed as separate items, and the second, is the typeface under consideration here. As it is the first typeface claimed by Le Bé to be his own creation, it is worth examining it in some detail to determine his starting point, his influences and how it may help us in recognising other typefaces shown in the documents.

Le Bé call this typeface a 'texte du talmuth', which combines two aspects. The first is for the size, which places it firmly as a standard sixteenth-century type size, between English and Great Primer, or about 16 points Didot. Wolf lists some ten mentions of this size from various sixteenth-century sources, many of them from Plantin and his press. In addition other terms such as 'lettre de texte', 'gros texte' and 'vray texte' also were current. The second part, 'de Talmuth', surely relates to its purpose, and Le Bé indicates that it was a term well known to himself, if not to other printers. He uses the same term for Hb9 (S) which he cut towards the end of his stay in Venice.²⁴⁸

Thus the term 'Texte du Talmuth' can be taken as a descriptive term, perhaps reflecting the anarchic state of nomenclature which existed in the sixteenth century and resulted in different names, sizes and moulds for English, French, Italian and Dutch types. The sizes listed for both the Hebrew matrices and punches in the Le Bé inventory of 1730 inventory are Canon, Parangon, St. Augustin, Gros Romain, Petit Texte or Nompaille and these sizes can be taken to be representative of the sizes Le Bé would have used later in his lifetime and for those types which found their way into the Le Bé foundry which was passed down to Jean Pierre Fournier in the eighteenth century.²⁴⁹

The text itself is most likely from the Babylonian Talmud, the Tractate Bava Batra, Chapter 1, Midrash 1 and deals with the law of *Hazakah*, meaning 'the acquisition of property by continued and undisturbed possession during a period of time prescribed by law'.²⁵⁰ Yet one is immediately struck by the fact that the specimen text does not correspond exactly with the *textus receptus* of the Talmud and contains

²⁴⁸ Wolf, *Terminologische Untersuchungen zur Einführung des Buchdrucks im französischen Sprachgebiet*, pp. 114-115. I am grateful to Hendrik Vervliet for his clarification on this point. See also Vervliet and Carter, *Sixteenth-century printing types of the Low Countries*, p. 16

²⁴⁹ Fournier and Morison, *L'Inventaire de la Fonderie Le Bé*, pp. 22, 25

²⁵⁰ See 'Hazakah' (<<http://www.jewishencyclopedia.com/articles/7412-hazakah>> [Accessed 10 June 2011])

various spelling errors and textual omissions, which is curious if one assumes that these early specimens were composed in Venice, where Jews were active as compositors and editors in the printers for whom Le Bé had contacts. The penultimate line appears to be a random setting without any meaning. The final line reads in Hebrew: *Guilielmus Lebay Tsarfati* or 'Guillaume Le Bé Frenchman'. Le Bé thus signed his creations from the very beginning of his career, as will be seen from further specimens and this indicates that he was aware of his role as an independent punchcutter. This is an important difference in the way types were produced in the sixteenth century as opposed to the Incunabula period. It also indicates that he thought it worthwhile to keep specimens of his type, perhaps for purposes of claiming ownership of the type and to prevent other printers such as Giustiniani from claiming sole use of the type. That this was indeed a problem at the time can be seen from the dispute between Aldus Manutius and the punchcutter Francesco Griffio of Bologna in 1502.²⁵¹

The typographic errors and omissions could lead one to the conclusion that the compositor was not a Jew and could not distinguish between the Hebrew letters *vav* (ו) and *zayin* (ז) – the typo in the first word – in the type case. This is not an inconsequential point in the history of Hebrew printing and has been remarked on as late as the seventeenth century.²⁵² Yet we do know that Jews worked as compositors and editors in Venice during the early sixteenth century, as Bomberg's editor Fra Felice da Prato had to apply to the Venetian Senate to obtain permission 'to keep Hebrew compositors and readers' and that 'it was necessary to have four Jews to superintend the printing, but that it would be impossible to induce them to come if they were obliged to wear the yellow cap, as they would be molested and insulted in the streets.'²⁵³ But this was perhaps a unique situation and not repeated in all places where Hebrew books were produced. Non-Jews were as much involved in the production of Hebrew books as were Jews.

Le Bé's annotation is interesting from a number of points of view. It gives us a nearly exact date for Le Bé's date of birth, i.e. in March or April of 1525. The dates Le Bé gives for the cutting of the type also fits quite closely to the election of Francesco Donato as the 79th Doge of Venice on 24 November 1545.²⁵⁴ It also locates the press of Marco Antonio Giustiniani in the Calle dei Cinque, a small street whose name still exists today and which was in the early 1540s near to the centre of the Venetian book trade near the Rialto Bridge.²⁵⁵ Indeed the second Hebrew edition published by

²⁵¹ Giovanni Mardersteig, 'Aldo Manuzio e i caratteri di Francesco Griffio da Bologna', in *Studi di bibliografia e di storia in onore di Tammaro de Marinis*. Verona 1964. (Verona, 1964), pp. 139-141

²⁵² Heller, *The seventeenth century Hebrew book*, pp. lxvi-lxvii. See also Lubell, *The Use of Hebrew in the Antwerp Polyglot Bible*, p. 49

²⁵³ Horatio Brown, *The Venetian printing press* (London: John C. Nimmo, 1891), p. 105

²⁵⁴ Adriano Capelli, *Cronologio Cronografia e Calendario Perpetuo* (Milano: Editore Ulrico Hoepli, 1983), p. 345

²⁵⁵ The Calle dei Cinque is situated in the Sestiere of San Polo and runs from the main axis connecting the Campo S. Aponal, Ruga Vecchia San Giovanni, to the Rialto Bridge and opens up on the Riva del Vin on the Grand Canal.

Giustiniani, *Sefer Rosh Emunah*, bears the inscription *BeRialto* (On the Rialto) in Hebrew on the title page.²⁵⁶ The Giustizia vecchia referred to in the annotation is most probably the present day Palazzo dei Camerlenghi, where the Uffici di Giustizia Vecchia was located. Two judicial bodies, the Giustizia Vecchia and Nuova, were established in 1261.²⁵⁷

What is perhaps most interesting is the mention of a 'messer Leon', whom Le Bé describes as a *personnier or parsonnier au fraitz et ouvrages*, which most certainly means 'partner' in this context.²⁵⁸ And, furthermore he describes messer (an old Italian term for sir or master) Leon as combining skills in print and editing, as well as keeping a shop for second hand and new clothes (*strazzaria* in Italian). This was indeed one of the occupations which Jews in Venice were allowed to practice in the sixteenth century and it throws an interesting light on the restrictions under which Jew lived.²⁵⁹ We do not know precisely who this Messer Leon was, but it was not an uncommon name for Jews during that period, as is seen for example in the fifteenth-century Italian rabbi, teacher, physician, and philosopher was known as Judah Messer Leon, and the later scholar, rabbi, and poet Leone da Modena.

Le Bé also mentions that Messer Leon was 'aucunement entendu aux meilleurs traitz et portraitz de l'escripture HEBRAÏQUE' (particularly knowledgeable about the best shapes and figures of Hebrew script).²⁶⁰ The implication is that Messer Leon might also have been a scribe, or a *Sopher* in Hebrew, in which capacity he might have prepared Jewish documents, such as Ketubot (Jewish wedding contracts), Gittim (divorce documents) or other documents needed by the Jewish community. Le Bé makes mention once again of this theme on Folio 14 of NAF 4528, where he annotates a Hebrew cut in 1573 in Paris and notes that he followed 'les meilleurs traictz et les plus receuz de l'antiquité au jugement des plus experimentez ès lettres hebraïques par ceux de leur religion et nation, en la ville et cite de Venise, où j'ay demeuré cinq ans et plus, suyvant les portraitz et brouillardz que j'en fis lors que je y estaoye'. This can only mean that Le Bé was in touch with Jews during his stay in Venice and was aware of the various scripts available to him at the time. An example of such a script is the following detail from a Ketubah produced in Venice in 1612 written in a clear Sephardic hand, and extended letters (*litterae dilatabile*) which are

²⁵⁶ Itzhak Abravanel, *Sefer Rosh Emunah*, (Venice: Giustiniani, 1544) BL 1952d9(4)

²⁵⁷ See Silvia Gramigna, Annalisa Perissa Torrini, and Roberto Lazzari, *Scuole grandi e piccole a Venezia tra arte e storia: confraternite di mestieri e devozione in sei itinerari* (Italy: s.n., 2008).

²⁵⁸ Bernard Cooperman, 'Organizing Knowledge for the Jewish market: An editor/printer in Sixteenth-century Rome', in *Perspectives on the Hebraic book: the Myron M. Weinstein memorial lectures at the Library of Congress*, ed. by Myron M. Weinstein and Peggy K. Pearlstein (Washington, D.C.: Library of Congress, 2012)

²⁵⁹ Riccardo Calimani, *The Ghetto of Venice* (Milano: Arnoldo Mondadori, 1995), p. 27. See also Umberto Fortis, *Il Ghetto sulla Laguna* (Venezia: Storti Edizioni, 1987), p. 21

²⁶⁰ Bernard Cooperman, 'Organizing Knowledge for the Jewish market: An editor/printer in Sixteenth-century Rome', (Washington, D.C.: The Library of Congress

to be found in several of the types cut by Le Bé. There is a strong similarity in the ayin on the bottom line, which is very clearly in the style of Le Bé's types.²⁶¹



Fig. 2.11: Jewish marriage document or Ketubah, produced in Venice in 1612 (St John's College Library, Cambridge MS N.34 539)

There appear to be few remaining *ketubot* (plural of *Ketubah* in Hebrew) which one could use as concrete examples of Hebrew scribal hands which Le Bé might have seen during his stay in Venice. Most of the surviving examples in collections are from the seventeenth century, but they all show a similar Sephardic hand, the use of *litterae dilatabile*, and the similar treatment of the letters ayin and shin. Two examples from the Braginsky Collection are typical: a 1638 ketubah from Rome and a 1648 specimen from Venice.²⁶² A further example is from the Querini-Stampalia Library in Venice and is dated 1637 or 1638. This hand too shows marked similarities to the Le Bé types.



Fig. 2.12: Assembled alphabet from MS CL.IX Codex XLII, enlarged (Bibliotheca, Fondazione Querini Stampalia, Venice)

²⁶¹ N.34 Ketubah. Venice, 1612. St John's College Library, University of Cambridge. See also page 82.

²⁶² Emile G. L. Schrijver et al., *Schöne Seiten: jüdische Schriftkultur aus der Braginsky Collection* (Zürich: Scheidegger & Spiess, 2011), pp. 172-175

Further evidence of the closeness with which Le Bé followed the Sephardic style can be seen in many early Hebrew manuscripts produced in the Iberian peninsula prior to the expulsion in 1492. A good example is from the Rylands Haggadah which is thought to have been produced in Catalonia in the mid-fourteenth century. The similarities are most obvious in the gimmel, the zayin, the peh, the tsadde and the shin, as shown in the following constructed alphabet from one of the folios.²⁶³ Note the pronounced left slant to these letters, as well as the slanted baseline, which has not been followed in Le Bé's typefaces. The appearing size of the letters is about 6 mm.



Fig. 2.13: Incomplete assembled alphabet from the Rylands Haggadah, Spain or Catalonia, mid-fourteenth century.



Fig. 2.14: Hb1(S) from NAF 1665 folio 11. A setting from Alvise Bragadin's edition of the *Mishneh Torah*, Venice, 1550. See BL shelfmark 1918e1, unnumbered folio containing text from Chapter 5 of *Chaluchat Yesodi HaTorah*, with the Migdal Oz Commentary by Rabbi Shem-Tov ben Abraham Ibn Ga'on.



Fig. 2.15: Specimen of Hb1(S) from the *Mishneh Torah*, Giustiniani, Venice 1550 Title page recto (BL 1918e4)

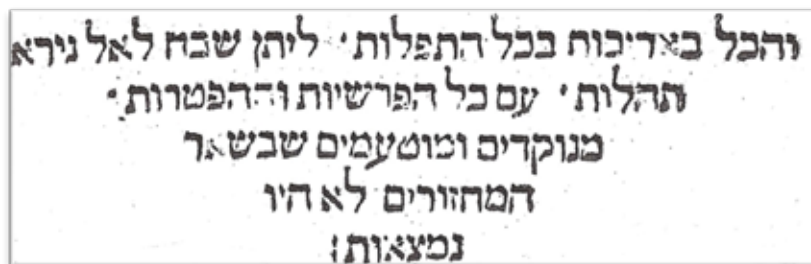

Fig. 2.16: Specimen of Hb1(S) from the title page of *Machzor Helek Sheni*, Bragadin, Venice 1599. (BL 1971f4)

If Le Bé had been able to attain an adequate understanding and control of the typographic requirements for Hebrew typefaces, what can be said about his knowledge of the Hebrew language? It is most probable that he was not educated in the Christian Hebraist tradition nor was he a Hebrew scholar, although he must have been able to read and write Hebrew at a basic level. This is shown by the attributions

²⁶³ Raphael Loewe, *The Rylands Haggadah: a medieval Sephardi masterpiece in facsimile* (London: Thames and Hudson, 1988), p. 96 (f.)

to himself in many of the type specimens.²⁶⁴ But it also seems clear that he was following certain traditions of design and layout which he had learned in his apprenticeship with Estienne and later absorbed during his period in Venice.

In the period of Le Bé's lifetime in France, the opportunities for contact between Christians and Jews were extremely limited due to social and religious restrictions on both sides. The medieval Church did not approve of such meetings and on the Jewish side 'few Jews consented to teach Hebrew to Gentiles'.²⁶⁵ There were quite a few notable Christian Hebraists active in Paris, such as Bishop Agostino Giustiniani (1470-1535), who taught Hebrew in Paris for a period in the 1520s, François Tissard (1455-1510), François Vatable (1490-1547) Jean Mercier (1510-1570), Antoine Rodolphe Chevallier (1507-1572), Guillaume Postel (1510-1581), Jean Cinquearbres (1514-1587), Gilbert Générard (1537-1591) and Guy Le Fèvre de la Broderie (1541-1598).²⁶⁶ It is known that Vatable and Mercier were both involved in the editing and production of Estienne's Hebrew Bibles, and that Mercier's Aramaic 'was good enough to translate the *Targumin*'.²⁶⁷ It is more than likely that Le Bé would have met them during his period at Robert Estienne's press and possibly used at least Jean Mercier for assistance on Hebrew texts later in his career.

The writer François Rabelais (c. 1494 –1553), of an earlier generation than Le Bé, is interesting for his extensive use of Hebrew words and texts in *Pantagruel* and the *Fourth Book*. The admonition of Pantagruel's father Gargantua is instructive as to the Renaissance vision of learning and the place of Hebrew within it.²⁶⁸ It has been noted that 'the Rabelaisian novels are rich in Hebrew terms and in numerous allusions to the Masoretic work' and that 'Rabelais was not a complete neophyte in the matter and knew enough Hebrew to find his way by himself in the Hebrew Bible'.²⁶⁹ The short Hebrew extract in Chapter 2.IX, despite errors, demonstrates

²⁶⁴ See for example the annotations to Folios 14 and 16 in N.A.F 4528.

²⁶⁵ Schwarzbach, 'Geddes in France', in *The Bible and the Enlightenment: a case study - Dr Alexander Geddes (1737-1802) : (the proceedings of the Bicentenary Geddes Conference held at the University of Aberdeen, 1-4 April 2002)*, ed. by Johnstone (London: T & T Clark International, 2004), p. 82

²⁶⁶ Sophie Kessler-Mesguich, 'Early Christian Hebraists', in *Hebrew Bible*, ed. by Magne Sæbø, C. Brekelmans, and Menahem Haran (Göttingen: Vandenhoeck & Ruprecht, 1996), Manuel, *The broken staff*, Albert van der Heide, *Hebraica veritas: Christoffel Plantin en de christelijke Hebraïsten: catalogus bij de tentoonstelling 'Hebraica veritas, sprak God Hebreuws?, Lashon ha-Kodesh mi-pi ha-gevurah, 16 mei-17 augustus 2008* (Antwerpen: Plantin-Moretus Museum/Prentenkabinet, 2008)

²⁶⁷ Schwarzbach, 'Geddes in France', in *The Bible and the Enlightenment: a case study - Dr Alexander Geddes (1737-1802) : (the proceedings of the Bicentenary Geddes Conference held at the University of Aberdeen, 1-4 April 2002)*, ed. by Johnstone (London: T & T Clark International, 2004), p. 81

²⁶⁸ I intend, and will have it so, that thou learn the languages perfectly; first of all the Greek, as Quintilian will have it; secondly, the Latin; and then the Hebrew, for the Holy Scripture sake; and then the Chaldee and Arabic likewise, and that thou frame thy style in Greek in imitation of Plato, and for the Latin after Cicero. Gargantua and his Son Pantagruel Chapter 2.VIII.—How Pantagruel, being at Paris, received letters from his father Gargantua, and the copy of them.

²⁶⁹ Katia Campbell, 'Notes sur l'hébreu de Rabelais: La rencontre avec Panurge (Pantagruel, chap. 9)', *Etudes Rabelaisiennes*, XXV (1991), Katia Campbell, 'Rabelais and the Massorah', in *Rabelais in context : proceedings of the 1991 Vanderbilt Conference*, ed. by Barbara Cherry Bowen (Birmingham, Ala.: Summa Pub., 1993)

some ability in reading and writing Hebrew. This is a possible model for the level of knowledge that Le Bé could have attained to enable him to cut Hebrew typefaces and attain a rudimentary level of reading and writing in Hebrew.

Le Bé would certainly have known by reputation the work of the earlier pioneers of Hebrew printing in Italy and more specifically in Venice, such as Aldus Manutius, Gershom Soncino and Daniel Bomberg. Aldus Manutius had ceased printing by 1515 and the Soncino family had moved to the Ottoman Empire by 1526.²⁷⁰ There is some debate as to when Daniel Bomberg finally returned to Antwerp from Venice, and he may well have done so before Le Bé arrived, yet we know that Le Bé was in contact with Cornelio Adel Kind, a partner and successor to the Bomberg press.²⁷¹ The Le Bé Hebrews build on the type of Sephardic letterforms used by these 'pioneers', but are a major step forward in redefining the typographic character of the Hebrew letter form. The following specimens comparing Square Sephardic Hebrew types used by Aldus Manutius, Gershom Soncino and Daniel Bomberg demonstrate the improved legibility, differentiation of characters, character fit and aesthetic quality as introduced by Guillaume I Le Bé from his very first typeface cut in 1545.²⁷²

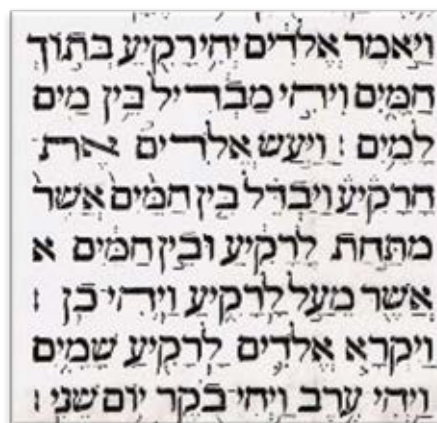

Fig. 2.17: Hebrew text from the 1500 proposed Polyglot Bible, printed by Aldus Manutius, Venice c. 1501 (By permission of Martin Davies)

²⁷⁰ See Martin Davies, *Aldus Manutius: printer and publisher of Renaissance Venice* (London: The British Library, 1995) and David Werner Amram, *The makers of Hebrew books in Italy: being chapters in the history of the Hebrew printing press* (London: Holland Press, 1963), pp. 139-145

²⁷¹ See Fernand van Ortroy, 'Les van Bomberghen d'Anvers: Imprimeurs, Libraires et Editeurs', *De Gulden Passer* (1924), p. 133 and Amram, *The makers of Hebrew books in Italy*, p. 180. See also page 310.

²⁷² See Fig. 2.19 for a comparison.



Fig. 2.18: Hebrew alphabet from the *Introductio utilissima hebraice discere Cupientibus*, Aldus Manutius, 1500 (Württembergische Landesbibliothek Stuttgart, Signatur: B hebr. 1516 01)



Fig. 2.19: Hebrew text from the Soncino Polyglot Torah printed by Eliezer ben Gershon Soncino in Constantinople in 1546 Actual size (From the Hebrew University Digitized Book Repository)

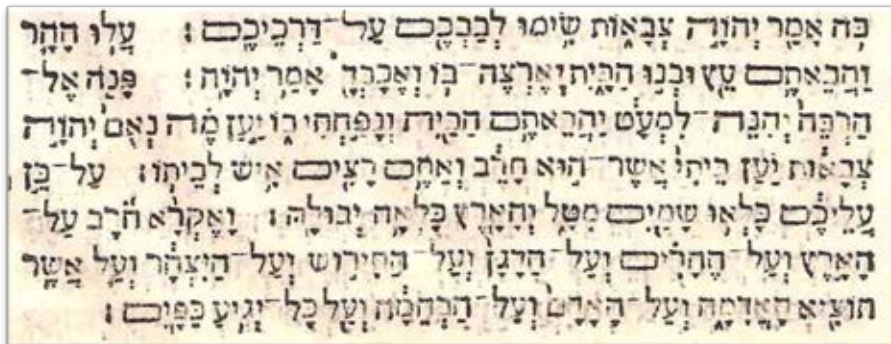



Fig. 2.20: The Bomberg Moyenne as used in the Plantin 1566 Hebrew Quarto Bible





Fig. 2.21: The Le Bé specimen of HB1 (S) (From NAF 4528 f.1.)

The key letter recognition factors

- 

Aleph: The termination to the left hand stroke has a distinct calligraphic flick that would have been produced by changing the angle of the pen or quill from 45 to 90 degrees.
- 

Extended aleph: Similar to the aleph but with a more pronounced flick to the termination. The lower left stroke has a decided angle and points inwards to the right.
- 

Bet: The right hand termination to the baseline stroke has a 45 degree angle. This is one of the problematic pairs (the bet and the kapf) in Hebrew that are commonly confused, especially in the smaller typeface sizes.
- 

Gimmel: The termination to the vertical stroke protrudes below the baseline. The upper termination has a distinct narrowing before joining the vertical stroke, a clear calligraphic feature.
- 

Dalet: The main differentiation between the dalet and the resh is the flat juncture between the vertical and horizontal strokes. The right hand vertical stroke has a distinct angle to the right.
- 

Heh: The right hand stroke has a slight curve to left. The counter of the heh is more rounded as opposed to the chet.
- 

Extended heh. The right hand stroke is much straighter than the letter heh.
- 

Zayin: The horizontal stroke joins the vertical stroke in the middle. The vertical stroke has a distinct calligraphic swelling from top to bottom which helps to differentiate it from the vav.



Chet: The counter is much squarer than the heh counter. This is one of the problematic pairs in Hebrew (the heh and the chet) that are commonly confused, especially in the smaller typeface sizes.

Tet: The termination to the right hand stroke has a 45 degree angle and does not touch the left hand stroke. The bottom stroke is flat to the baseline.

Yod. This character displays a pronounced angle to the two strokes.

Kapf: The baseline protrudes beyond the termination of the upper horizontal stroke.

Final Kapf: The vertical stroke has a distinct angle to the right.

Lamed: The termination to the ascender has a left facing flag and the ascender has a distinct curve from the horizontal middle stroke

Mem: The baseline stroke is slightly angled and touches the left hand stroke.

Final Mem: The counter shape is squarer to differentiate it from the samekh.

Nun: The upper horizontal stroke is much shorter than the baseline stroke and the vertical stroke is much more vertical to differentiate it from the Kapf.

Final Nun: The vertical stroke has a distinct calligraphic swelling from top to bottom.

Samekh: The baseline stroke curves upwards and narrows where it joins to the right hand vertical stroke. The curved baseline and left hand vertical provide the main differentiation from the final mem.

Ayin: The ascender has a distinct angle and protrudes beyond the main body of the character. The termination to the tail stroke is squared off.

Peh: the middle stroke is very similar to the left hand stroke of the aleph.

Final Peh: the middle stroke has a more distinct angle than the peh.

Tsadde: The base stroke is flat and both termination flags point outwards. Later Le Bé Hebrews (i.e. HB14 (S)) have both terminations strokes pointing to the left.

Final Tsadde: The descender is almost vertical.

Resh: The main differentiation between the resh and the dalet is the curved joining between the vertical and horizontal strokes. The vertical stroke is more nearly straight than the dalet vertical stroke.

Shin: The flag of the termination of the middle stroke points right. The middle stroke joins the baseline very close to the left hand vertical stroke. The flags of the left and right hand strokes point left. The baseline curves upwards and narrows where it joins the left hand stroke. This characteristic was maintained consistently throughout Le Bé's Square Sephardic Hebrews and follows the model used by Jean Arnoul (Le Picard) in the Hebrews he cut for Robert Estienne. The letter shin in manuals for Jewish scribes has all three termination strokes pointing to the left.

Tav: The upper horizontal stroke is slightly shorter than the resh and the left vertical protrudes well beyond the main body of the character.

Aleph/Lamed Ligature: The vertical down stroke makes a 45 degree turn to the right where it joins the right hand shorter vertical. The termination to the vertical right hand stroke is a short continuation of the main ductus.

Fig. 2.22: Hb1(S): Assembled alphabet at actual size = approx. 2.7 mm (From NAF 4528 f.1.)

Hb1(S) was found in the following printed editions during the search of primary material. The earliest use thus appears to be in 1550 and the typeface was distributed across a wide spectrum of Hebrew presses in Venice, not only with Giustiniani, for whom it was originally cut. It also was found in Hebrew editions printed in Basle and Freiburg im Breisgau in Germany.

Attributions for this typeface in printed editions:

- *Hilkhot Shehita uVedukah*, Venice, Adelkind, 1550
- *Mishneh Torah*, Venice, Giustiniani, 1550?
- *Sefer Birkat Avraham*, Venice, Bragadin, 1552
- *Sefer Orah Hayim*, Venice, Bragadin, 1563
- *Shulhan Arukh*, Venice, Bragadin, 1565
- *Mishneh Torah*, Venice, Bragadin, 1574
- Koppelman, *Sefer Misle Su'alim*, Freiburg im Breisgau, Zifroni, 1583
- Benjamin Tudela, *Masa'ot shel Rabi Benjamin*, Freiburg im Breisgau, Zifroni, 1583?
- *Sefer Toledot Aharon*, Freiburg im Breisgau, Zifroni, 1584?
- *Tsemach David*, Venice, Giovanni de Gara, 1586
- *Machzor*, Venice, Bragadin and di Gara, 1599
- Moshe de Léon, *Zot HaSefer HaNefesh HaHochma*, Basle, Waldkirch, 1608

Hb2 (R)

Appears on NAF 4528 folio 1
Type Classification: Rashi Script unpointed
Type size/name: Grosse Glose?
Measurements x-height of 2 mm; 10 lines = 52 mm
Date and place of creation: Unknown
Punchcutter: Unknown
First occurrence: *Pirkei Avot*, Venice, Giustiniani, 1545

Le Bé makes no mention of this rabbinical script in his annotated notes to Folio 1, and does not claim it as one of his creations. This is curious, as the rabbinical text is printed on the same sheet as Hb1(S) and pasted into the document. It is also very close in style to Hb5 (R), which Le Bé *does* claim as his third Hebrew and to Hb7(R), which Le Bé claims as his fifth and also dates to 1547. Closer examination of the two most similar in size, Hb2 (R) and Hb7(R), show subtle differences in the bet, gimmel, shin, final tsadde (ך) and tav. Furthermore, it appears quite consistently in the Hebrew publications of Giustiniani from the first imprints of 1545, which would tie it in with other Le Bé types used by Giustiniani.²⁷³ It is definitely different from the Bomberg rabbinicals, which have a distinctive final nun.²⁷⁴ Further investigation may yet turn up an earlier example of this rabbinical, but for the time being we must assume that, for whatever reason, Le Bé did not want to claim this type as one of his creations. This similarity also raises the question as to whether Le Bé's dates are unreliable or perhaps that he did not include *all* his types in these documents.²⁷⁵

The text of the specimen is also problematic. Given the type used, it can only be a legal code or a sermon. A search on the Bar Ilan Responsa Project database came up with some three possible texts, but no certain ones.²⁷⁶ The text does have the line 'I the younger (son?) from the house of my father Yosef ben rabbi Itzhak from the house of Alofela (Elopela)' which is the type of text one might expect from rabbinical responsa or commentary. The best hypothesis at present is that it is related to the main text above it, dealing with the law of *Hazakah*.

²⁷³ The British Museum Catalogue of Italian Books gives the date of the first Hebrew edition printed by Marco Antonio Giustiniani as 1545.

²⁷⁴ See Hb34 (R) on p. 274 for example.

²⁷⁵ I am grateful to Professor Hendrik Vervliet for these observations.

²⁷⁶ Bar Ilan University, 'Short Global Jewish Database (the Responsa Project)', Bar Ilan University, (2011) <<http://www.biu.ac.il/jh/Responsa/>>. I am indebted to Rabbi Alex Chapper of the Ilford Federation Synagogue for his opinion that there are 'a number of mistakes in the wording but it definitely appears to be an attempt at setting a halachic code possibly something like the Shulchan Arukh, Tur or Rambam Mishne Torah'. (Email communication 29 June 2011)

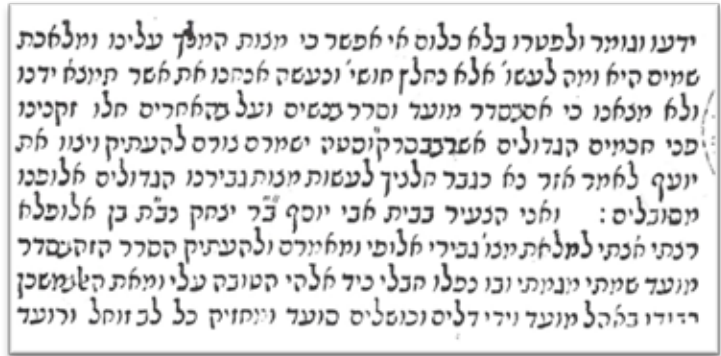

Fig. 2.23: from NAF 4528 folio 1. Original size showing lower specimens (Actual size)

A final word of caution is necessary when discussing these Rabinical types. The appearing size is of course one major difference between the 16 Rabinical types described in this thesis, but it has to be emphasised that in most cases the recognition factors between the typefaces are far fewer and more elusive than in the Square Sephardic types. This close similarity in detail can be seen in the following comparison of Hb2 (R) to two other Rabinical types cut by Le Bé.



Fig. 2.24: Comparison of Rabinical types Hb2 (R) to HB5 (R) and Hb 7 (R) – Enlarged about 2x

The complete alphabet and key letter recognition factors

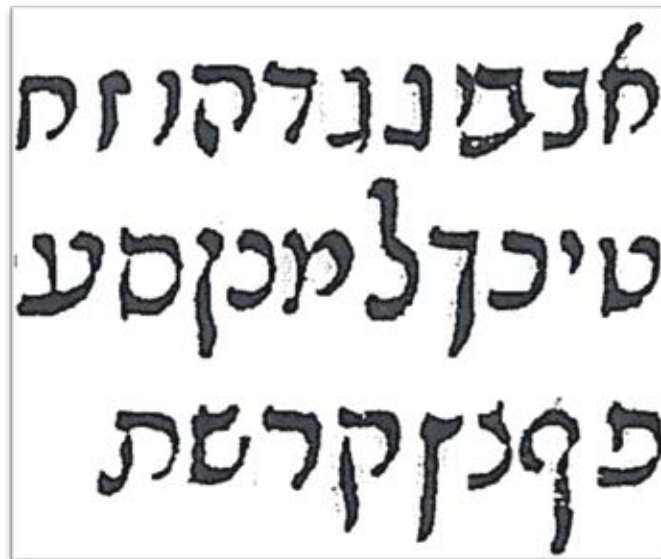

Fig. 2.25: Hb2 (R) complete alphabet enlarged to approximately 10 mm appearing size.



Fig. 2.26: Hb2 (R) complete alphabet at actual appearing size (2.00 mm x height).



Aleph: The upper ascender joins almost directly to the left vertical stroke.

Bet: The second version has an angled curve base stroke.

Lamed: The ascender has a slight angle to the left and distinct flag pointed left.

Mem: The right vertical stroke is shorter than the left vertical.

Final Nun: The termination flag faces left, which is a clear difference to the Bomberg Rashi types.

Ayin: The base stroke protrudes beyond the left vertical stroke.

Final Tsadde: Compare to the version used by printer Daniel Bomberg – Hb34 (R) – which has a curved calligraphic stroke facing left.

Tav: The left stroke has a thickened swell where it joins the upper horizontal stroke.

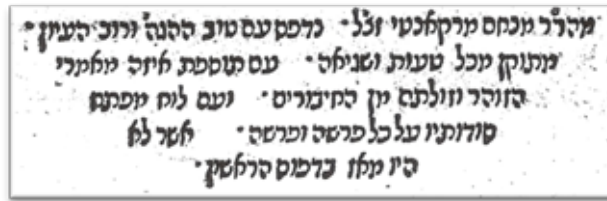

Fig. 2.27: Hb2 (R) from *Be'ur al HaTorah*, Venice, Giustiniani, 1545 Title Page (BL 1968d16)

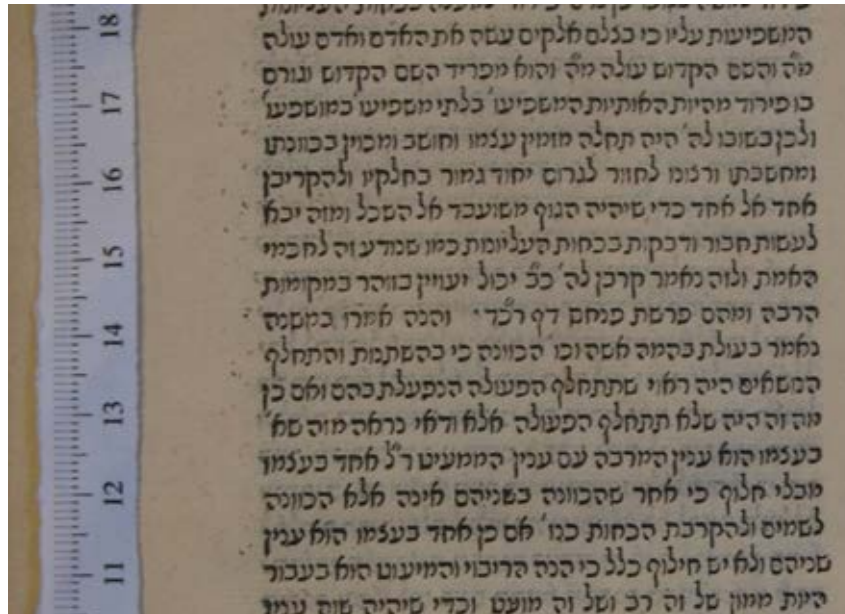

Fig. 2.28: Hb2 (R) from *Divrei Shelomo*, Venice, Zanetti, 1598 .Title Page.(UCL SC, SR Mocatta 1595-96 LS)

The number of definite and questionable finds for this type adds further evidence for Le Bé's involvement in this type. The elements of ink squash, paper shrinkage and poor impression make positive identification difficult in all cases, but it was clearly a useful type for the types of Hebrew editions being produced during the sixteenth century and thus widely used by Hebrew presses, not only in Venice and further a field in Italy, but also in Poland.

Attributions for this typeface in printed editions:

- *Pirkei Avot*, Venice, Giustiniani, 1545
- *Igrot leha-ma'or ha-gadol, ha-ner ha-ma'aravi*, Venice, Giustiniani, 1545
- *Sefer Zevah Pesah*, Venice, Giustiniani, 1545
- *Be'ur al ha Torah*, Venice, Giustiniani, 1546
- *Sefer Shulhan Arba'ah*, Venice, Giustiniani, 1545
- *Midrash Rabot*, Venice, Giustiniani, 1545
- *Otiot shel Rabi Akiba*, Venice, Giustiniani, 1546
- *Babylonian Talmud*, Venice, Giustiniani, 1546/50
- *Beit Ya'akov*, Venice, Giustiniani, 1547

- *Halakhot Gedolot*, Venice, Giustiniani, 1548
- *Mishnah*, Venice, Meir di Parenzo in casa di Carlo Querini, 1548/49
- *Sefer Hazut Kashah*, Sabionetta, Foa, 1552
- *Sefer Birkat Avraham*, Venice, Bragadin, 1552
- *Humshe Hamishah Torah*, Ferrara, Usque, 1554?
- Benjamin Tudela, *Masa'ot shel Rabi Binyamin*, Ferrara, Usque, 1556?
- *Sefer Toledot Yitzhak*, Mantua, 1558?
- *Sefer Arba'ah Turim*, Cremona, Conti, 1558
- *Sefer Hovat HaLevanot*, Mantua, 1559
- *Shirei Musar HaSekhel*, Mantua, Rufinelli, 1560
- *Bible/Sefer Tehilim*, Cremona, Conti, 1561?
- *Shoresh Yishai*, Constantinople, Usque, 1561?
- *Sefer Ruach Hen*, Cremona, Conti, 1566
- *Sefer Haguda*, Cracow, Prostitz, 1571?
- *Mishneh Torah*, Venice, Bragadin, 1574
- *Sefer Divrei Shelomo*, Venice, Zanetti 1595-96
- *Sefer Urim ve Tumin*, Venice, Zanetti 1603?

Hb3 (S)

Appears on NAF 4528 f. 2, Rés X 1665 f. 10 and Rés X 1665 f. 10v

Type Classification: Square Sephardic unpointed and pointed

Type size/name: Unidentified

Measurements x-height of 2.8 mm

Date and place of creation: 1546 in Venice?

Punchcutter: Guillaume I Le Bé?

The specimen of this typeface appears in three of the Le Bé specimens, which are described in Hb4 (S). The specimen consists of two words and a total of eight characters as shown below. The specimens on NAF 4528 folio 2 and Rés X 1665 f. 10v are pointed, whereas the specimen on Rés X 1665 f. 10 is unpointed.

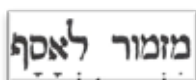

Fig. 2.29: Hb3 (S) shown at actual size from NAF 4528 f. 2

The date on the specimen and the very characteristic treatment of the final peh (פ) and the ascender of the lamed identify this specimen beyond any doubt as a Le Bé type. In addition, the close similarity in all but size to Hb1(S) confirms the identity of the punchcutter. In terms of size, the closest match in the Hebrews in the Plantin Moretus matrices is the Vrai Texte Hebreu (MA 167a or MA 164a).

A comparison at an enlarged size with the assembled alphabet from Hb1 (S) confirms the very clear similarity of the letter forms, with the exception of the treatment of the ascender of the Lamed. In Hb3 (S) the upper stroke is much thicker and the termination flag larger and less angled than in Hb1 (S). The accents (Nikkud) in two of the specimens appear to be identical to those used in Hb4 (S), yet they very clearly sit *below* the body of the letter, whereas in Hb4 (S), they are much closer to the type body. This would mean that they were not cast with the type, but set as a separate line, with ascenders and descenders cast as kerned or overhanging characters on the lines above or below.²⁷⁷



Fig. 2.30: Hb3 (S) shown enlarged to x-height of approximately 10 mm

This typeface raises several intriguing questions. Why does it appear only appear in this specimen? Why does Le Bé make no claim for its creation? Why does it not appear in any of the Giustiniani imprints examined between the years 1545 to 1547? One hypothesis is that it was a cause of some dispute between Le Bé and Giustiniani which resulted in the type being withdrawn from use. Another more plausible

²⁷⁷ I am grateful to professor Hendrik Vervliet for this clarification. See example on page 91.

hypothesis is that Le Bé simply neglected to claim this type when he assembled the document, as he was more concerned with the main specimen – Hb4 (S) –in the sheet.

The text of this specimen reads ‘Mizmor le Asaf’ (A Psalm of Asaph), which is the opening to Psalms 79: 1-5

No editions using this typeface were found, which may be partially due to the small number of key recognition characters in the specimen. Further examination of Hebrew imprints from the sixteenth century may yet turn up a clue as to the origins of this type and where it was first used.

Hb4 (S)

Appears on NAF 4528 folio 2, Rés X 1665 f. 10 and Rés X 1665 f. 10v

Type Classification: Square Sephardic unpointed and pointed

Type size/name: Moyenne or Texte Moyen

Measurements: x-height of 2.3 mm; 10 lines = 51 mm (pointed); 10 lines = 50 mm (unpointed);

Date and place of creation: 1546 in Venice (his second numbered type)

Punchcutter: Guillaume I Le Bé

Literature: Omont 1889, p. 8

First occurrence: *Candelabrici typici in mosis tabernaculo isusu divino expressi brevis ac dilucida interpretation*, Guillaume Postel, Venice, 1548?

Le Bé in his annotation states that this is his second Hebrew type, cut in 1546 in Venice for Marco Antonio Giustiniani. The same specimen reappears in Res X 1665 on folios 10 and 10v, the difference being in the pointing to the text. NAF 4528 folio 1 is pointed throughout the text, whereas the specimen on Res X 1665 f. 10 is pointed only on the first three lines with an additional line of text added, and Res X 1665 f. 10v is pointed throughout and appears identical to NAF 4528 folio 1. The specimen on Res X 1665 f. 10v also has cantillation marks (*Ta'amin* in Hebrew) added to the three first lines in addition to the pointing.

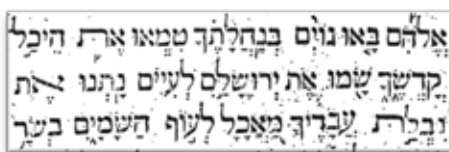

Fig. 2.31: Hb4 (S) Pointed setting with cantillation marks from Rés X 1665 f. 10 (Actual size)

We are faced here with the question as to why Le Bé would have decided to repeat what is essentially the same setting, not once, but three times. His annotations do not contradict each other as to names and dates.²⁷⁸ There are three missing letters in (NAF 4528 folio 1) which on closer inspection show that they were cut out. This is not the only instance of repetition of specimens in the two documents, so one can only conclude that they were compiled at different times or that Le Bé did not have the first document to hand when compiling the second.

The name given to this typeface by Le Bé raises various questions. Moyenne is a size found three times in the 1730 Inventaire as either 'moyen' or 'moienne', although it does not appear to be on the 'standard' old French sizes. Vervliet argues that it is a 'normal name for the size between English and Great Primer', but it is not defined as such by Wolf in his listing of sixteenth-century type sizes.²⁷⁹ In the sizes used in the *Officina Plantiniani* we find a 'Moyen Canon', but this is equivalent to about 30 points Didot and thus not the same as referred to by Vervliet. Baines Reed does refer

²⁷⁸ Omont noted this repetition but made no suggestion for its reasons. Omont, *Specimens de caractères hébreux, grecs, latins, et de musique gravés à Vénise et à Paris par Guillaume le Bé, 1545-1592*, p. 8 (Note 2)

²⁷⁹ Comment on earlier draft version of this thesis by Professor Hendrik Vervliet. See Wolf, *Terminologische Untersuchungen zur Einführung des Buchdrucks im französischen Sprachgebiet*

to Moyenne in the Le Bé corpus of type sizes and notes that ‘the nomenclature seems to be in process of formation’. He also adds that Moyenne ‘might have become a regular size, like the German Mittel and Dutch Mediaan’.²⁸⁰

The closest in actual x-height size would be 9pt Didot, which would make it equivalent to English Long Primer or Old French Petit Romain. The line count for a solid setting of 86 mm to 20 lines would bring it closer to English Pica or Old French Cicero, yet a comparison to the Colines Great Primer Hebrew shows that the x heights are very close.²⁸¹ As Le Bé does use this term for five of his types, we must assume that the term had a specific meaning for him. It is possible that he was referring to a size for a mould then currently in use in France and Italy.

The specimen text in all three cases is from Psalms 79: 1-5, a Psalm of Asaph. This same verse is used in a later specimen in this same document on Folio 12. The final line has Le Bé’s signature as usual in Hebrew letters: *Guilermo LeBay Tsarfati*, or Guillaume Le Bé Frenchman. Note that here Le Bé uses the Italian form of his name, and not the Latin as in the first specimen.

When cutting this second Square Sephardic, Le Bé followed very closely in detail his first Hebrew. Perhaps he was asked by Giustiniani to produce a slightly smaller type with pointing for use in the setting of biblical texts. Once again the key recognition characters are the lamed, the ayin, the shin and the aleph/lamed ligature, but in this typeface the aleph/lamed ligature is quite distinct and closer to the scribal models.

The first appearance of this typeface appears to be Guillaume Postel’s *Interpretation du candelabre de Moïse* or *Candelabrus typici in Mosis Tabernaculo* printed in Venice in 1548. There is one line of text on the title page and the printer is not mentioned. The *Candelabri typici in Mosis Tabernaculo* does contain a foldout placard and it is possible that is one of the Hebrews on it.²⁸² There is a suggestion that Postel was in contact with Daniel Bomberg in Venice, who financed in part a trip that Postel made to Cairo, Jerusalem, Damascus and Constantinople in search of Arabic manuscripts of the New Testament and with whom he was planning to produce a New Testament in Syriac. The uncertain dates of Bomberg’s final departure from Venice put this idea in doubt, but it does raise the question of whether the *Candelabri typici in Mosis Tabernaculo* might have been issued by Bomberg’s press.²⁸³

What is more interesting is the use of this typeface in the two competing versions of the *Mishneh Torah* printed in Venice in 1550, one printed by Marco Antonio

²⁸⁰ Reed and Johnson, *History of the old English Letter Foundries*, p. 28

²⁸¹ Vervliet, *French Renaissance Printing Types: A Conspectus*, p. 406

²⁸² For a discussion of Postel’s French editions see Claude Postel, *Les Ecrits de Guillaume Postel publiés en France et leurs éditeurs 1538-1579, Travaux d’humanisme et Renaissance ; no.265.* (Genève: Droz, 1992), Guillaume Postel and François Secret, *Interprétation du Candelabre de Moïse en hébreu, latin, italien et français, avec une introduction* (Nieuwkoop: De Graaf, 1966) for a facsimile of this Venetian edition.

²⁸³ Postel, *Les Ecrits de Guillaume Postel publiés en France et leurs éditeurs 1538-1579*, p. 17

Giustiniani and the other by Alvise Bragadin. Le Bé makes no mention of cutting any types for Alvise Bragadin in his notes in either of the two documents and one would have assumed from the dispute between the two printers that they would not have cooperated in the use of type. It has been noted that ‘instability and ruinous competition were typical of the printing industry of that era’.²⁸⁴ Yet it also has to be said that editors such as Meir di Parenzo worked for a number of printers, notably Bomberg, Giustiniani and Querini, so the same would have been the case for punchcutters, of whom there were probably very few of any great reputation working in Venice at the time.²⁸⁵

The result of this the legal conflict between the two printer publishers was the Papal ban on the Talmud and the burnings of Hebrew books in Rome in 1551 and in Venice in 1553.²⁸⁶

The two typefaces used in the Giustiniani and Bragadin versions of the *Mishneh Torah* are also cast on the same body size, that is unpointed with a line measurement of 86 mm to 20 lines. This would indicate that they were cast from the same mould. The specimens in the BnF documents were cast on a larger body size, that is 108 mm to 20 lines presumably in order to incorporate the pointing and cantillation marks. An examination of the Le Bé punches and matrices held in the Plantin Moretus Museum shows that the accents and cantillation marks were cut as *separate* punches and in some cases – i.e. the Dagesh point in the centre of some letters) struck afterwards into the matrix.²⁸⁷

²⁸⁴ Neil Weinstock Netanel, 'Maharan of Padua v. Giustiniani: the Sixteenth Century Origins of the Jewish Law of Copyright', *The Houston Law Review*, 44 (2007), p. 833

²⁸⁵ The files compiled for the Duca di Rivoli in the Archivio di Stato in Venice do show various mentions of the terms *intaglior* (engraver), *justador de letere* (justifier of type?), *corrector di litere hebrae* (corrector of Hebrew letters), *gitador de lettere da stampa* (type founder), *fontador di lettere* (type founder), or *Ruitador da lettere* (perhaps a Venetian term for letter engraver?). It is not clear what particular trade these various terms indicate. The relevant printing craft or guild in seventeenth-century Venice was *Fonditori* (type founders). See Richard Tilden Rapp, *Industry and economic decline in seventeenth-century Venice*, *Harvard historical monographs* ; no. 69. (Cambridge, Mass: Harvard University Press, 1976), p. 173

²⁸⁶ This episode has been widely discussed, but the most comprehensive discussion can be found in Netanel, 'Maharan of Padua v. Giustiniani: the Sixteenth Century Origins of the Jewish Law of Copyright',

²⁸⁷ I am indebted to Hendrik Vervliet and Fred Smeijers for clarification of this point. For further discussion see Fred Smeijers, *Counterpunch: Making type in the sixteenth century, designing type now* (London: Hyphen Press, 1996). See page 188 of this thesis for discussion of this technique and its implications.

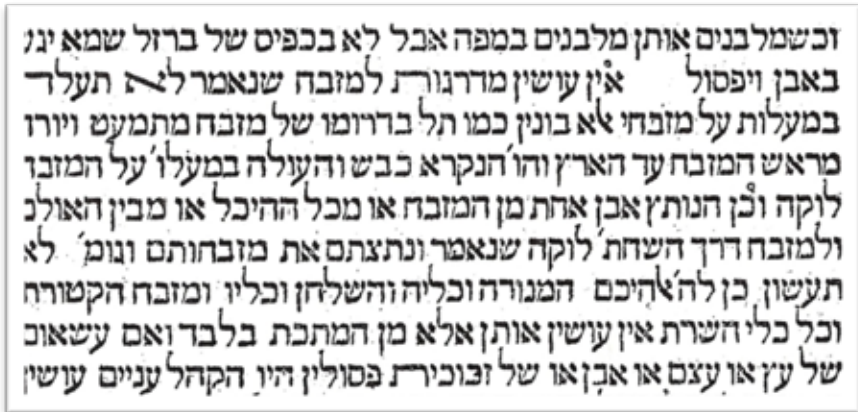

Fig. 2.32: Hb4 (S) from the *Mishneh Torah*, Venice, Giustiniani, 1550. (BL 1918e4)



Fig. 2.33: Hb4 (S) from *Mishneh Torah*, Venice, Bragadin, 1550 (BL, 1918e2)

Another technique for casting pointed or accented characters involved the use of stepped punches. They are known in French as *accents postiches*, due to their resemblance to wigs or perruque²⁸⁸ and can be seen Fournier's *Manuel Typographique*.²⁸⁹ Hendrik Van den Kerre and Robert Granjon both used them in four of the sets of punches they supplied to Christophe Plantin and which are held in the MPM in Antwerp.²⁹⁰ There are also stepped Hebrew punches in the Cabinet de Poinçons in Ivry, but they are probably nineteenth century ones.²⁹¹

Judging from the surviving punches in the MPM, Le Bé did not make use of this technique for his Hebrews, although stepped punches for Hebrew were found at least five of the sets of punches examined in the Athias Cabinet (Het Athiaskastje) in

²⁸⁸ I am grateful to M. Christian Paput formerly of the Imprimerie Nationale in Paris for his information on this point.

²⁸⁹ Fournier and Carter, *Fournier on Typefoundry*, pp. 84-85, Mosley, *A Dictionary of Punchcutters for Printing Types*. See also Plate IV, items 10 and 11 for illustrations.

²⁹⁰ From the MPM archives : ST11 (Reale Romaine, Hendrik van den Kerre, 1575), ST16 (Philosophie Romaine, Hendrik van den Kerre, c. 1578), and ST 49 (Jolie Grecque, Robert Granjon, cut to Plantin's order of 1574-75).

²⁹¹ There are four Hebrews listed in the Imprimerie Nationale's *Inventaire* of 1903. Two are listed as having been cut by Aubert and two by Marcellin Le Grand. For further details on these punchcutters see Mosley, *A Dictionary of Punchcutters for Printing Types*, p. 2 and 37

Amsterdam. These appear to be from the press of the Jewish Printer Joseph Athias (active in Amsterdam 1634/45 to 1700) and were preserved by his successors the Proops family and the printer Israel Levisson. Curiously there are examples of stepped punches for a set of punches for Rashi script, a character which normally is not set with accents.²⁹² As the technique was clearly known to punchcutters in the sixteenth century, it is a question for speculation at this point as to why Le Bé did not make use of it.



Fig. 2.34: Stepped and normal Square Hebrew (hebreeuwsch vierkante Letter) punches from the Athias Cabinet (Drawer 5) (The University of Amsterdam Special Collections)

²⁹² Universiteitsbibliotheek Amsterdam and John A. Lane, *Een punt voor typografie: De Typografische Bibliotheek in de Universiteitsbibliotheek Amsterdam* (Amsterdam: de Universiteitsbibliotheek Amsterdam, 2001), pp. 20-21. See also A. K. Offenbergh, 'A Hidden Treasure in the Athias Cabinet or Quid Novum in Armariolo Athii', *Zutot*, 2 (2002), A. K. Offenbergh, 'The Hidden Treasures of Athias', *Quaerendo*, 37 (2007)



Fig. 2.35: Stepped and normal Rashi Script punches from the Athias Cabinet (Drawer 5). (The University of Amsterdam Special Collections)

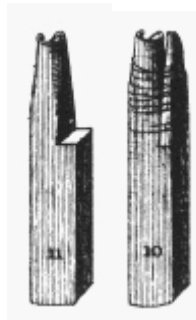

Fig. 2.36: Diagram showing stepped punch with and without accent attached (From *Fournier's Manuel Typographique* Plate IV, items 10 and 11)



Fig. 2.37: ST11 Reale Romaine by Hendrik van den Kerre showing lower case e stepped punch



Fig. 2.38: ST49 Jolie Grecque Granjon showing lower case character stepped punch with four accents



Fig. 2.39: Hb4 (S) as shown on the title page of Guillaume Postel's *Candelabri typici in mosis tabernaculo isusu divino expressi brevis ac dilucida interpretatio*. Venice, 1548.

The complete alphabet and key letter recognition factors



Fig. 2.40: Hb4 (S) Assembled alphabet from NAF 4528 f. 2 enlarged to approx. 10 mm x-height



Fig. 2.41: Hb4 (S) Assembled alphabet from NAF 4528 f. 2 (Actual size)

The four characters in this font which differentiate it most strongly from Le Bé's first Square Sephardic – HB1 (S) – are the aleph, the extended aleph (א), the final kapf (ך), the lamed, the ayin, final tsadde and the aleph/lamed ligature. Note the triangular termination 'hook' on the lamed and the aleph/lamed ligature, the straighter left hand stroke on the extended aleph (א), and the reduced angle on the aleph/lamed left hand stroke. Otherwise most of the characters follow much the same pattern in both founts. Hb4 (S) appears to have the standard dagesh points – the 'begadkephat letters' – and vowel points, although the text sample is not comprehensive enough to show all possible glyphs.

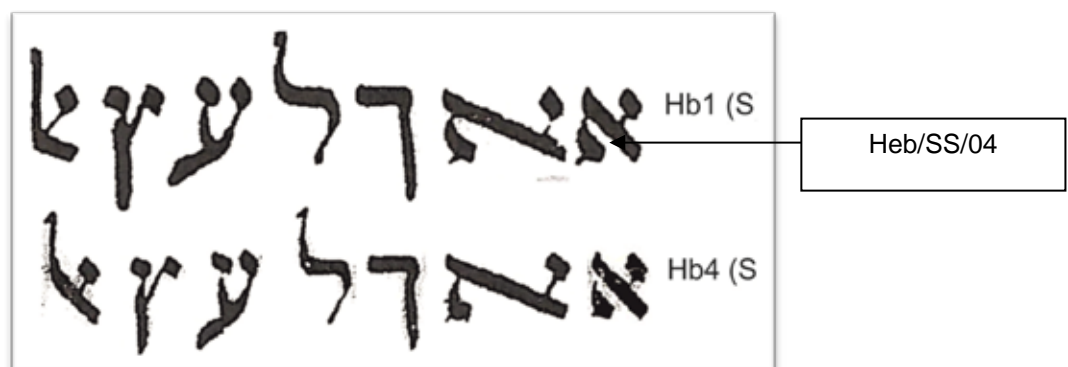
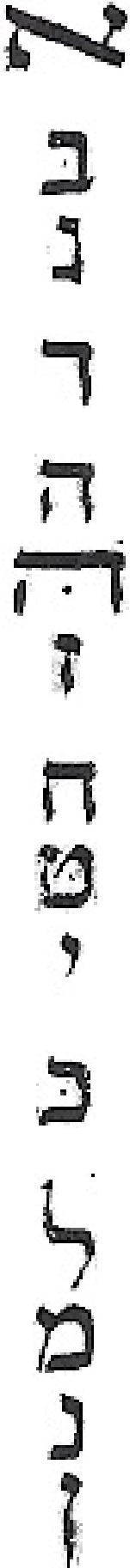

Fig. 2.42: Comparison of Hb 1 (S) and Hb4 (S)



Aleph: The termination to the left hand stroke has a distinct calligraphic flick.



Extended aleph: Similar to the aleph but with a more pronounced spike to the termination. The lower left stroke has a much more vertical stem than in Hb1(S) .

Bet: The right hand termination to the baseline stroke has a 45 degree angle.

Gimmel: The termination to the vertical stroke protrudes below the baseline. The upper termination has a distinct narrowing before joining the vertical stroke, a clear calligraphic feature.

Dalet: The main differentiation between the dalet and the resh is the rounded juncture between the vertical and horizontal strokes. The right hand vertical stroke has a distinct angle to the right.

Heh: The right and left hand strokes have distinct angles to the right.

Extended Heh. The right hand stroke is much straighter than the letter heh.

Zayin: The horizontal stroke joins the vertical stroke in the middle. The vertical stroke has a distinct calligraphic swelling from top to bottom which helps to differentiate it from the vav.

Chet: This chet is quite close to the heh and the left hand stroke does not stand out as much.

Tet: The termination to the right hand stroke has a 45 degree angle and protrudes deeper into the counter of the letter.

Yod. This character displays a pronounced angle to the two strokes, and is very similar to the calligraphic examples which so influenced Le Bé.

Kapf: The baseline protrudes beyond the termination of the upper horizontal stroke. In smaller sizes it is not stand out enough from the bet.

Lamed: The termination to the ascender has a left facing flag which is more bracketed than in Hb1(S) .The ascender has a distinct curve from the horizontal middle stroke.

Mem: The baseline stroke is slightly angled and almost touches the left hand stroke.

Nun: Another letter often taken for a Kapf in smaller sizes.

Final Nun: The vertical stroke has a distinct calligraphic swelling from top to bottom. The termination flag to the ascender points right.



Samekh: The baseline stroke curves upwards and narrows where it joins to the left-hand vertical stroke. The curved baseline and left hand vertical provides the main differentiation to the final mem.



Ayin: The descender has a distinct angle and protrudes beyond the main body of the character. The termination to the descender has a 45 degree angle.



Peh: The middle stroke is very similar to the left hand stroke of the aleph.



Final Peh: The middle stroke has a more distinct angle than the peh and the descender is more pointed than in Hb1(S).



Tsadde: The base stroke is flat and the termination flag to the right points right.



Resh: The main differentiation between the resh and the dalet is the curved joining between the vertical and horizontal strokes. The vertical stroke is nearly straight as opposed to the dalet vertical stroke.



Shin: The flag of the termination of the middle stroke points right. The middle stroke joins the baseline very close to the left hand vertical stroke. The flags of the left and right hand strokes point left. The baseline curves upwards and narrows where it joins the left hand stroke. This characteristic was maintained throughout Le Bé's Square Sephardic Hebrews.



Aleph/Lamed Ligature: The vertical down stroke makes a more gradual turn to the right, where it joins the right hand shorter vertical. This is one of the key recognition factors to distinguish Hb4(S) from Hb1(S)

Hb4 (S) was found in the following printed editions during the search of primary material. Once again there is a concentration of use in Venice and then further use outside Italy later in the century.

Attributions for this typeface in printed editions:

- *Candelabrics typici in mosis tabernaculo isusu divino expressi brevis ac dilucida interpretation*, Guillaume Postel, Venice, 1548
- *Mishneh Torah*, Venice, Bragadin, 1550
- *Derech Emunah*, Padua, Pasquato, 1652
- *Sefer Meir Iyov*, Venice, di Cavalli, 1567
- *Shulhan Arukh*, Venice, di Cavalli, 1567,

- *Sefer Toledot Aharon*, Venice, Bragadin, 1591
- *Sefer Harukh*, Basel, Waldkirch, 1599?
- Mayr, *Institutiones Linguae Hebraicae*, Augsburg, Mangius, 1616?

Hb5 (R)

Appears on NAF 4528 folios 3, 5 and 6; Rés X 1665, folios 14 and 14v

Size: Coursive Moyenne

Type Classification: Rabbinical (Rashi) or Texte Moyen

Measurements x-height of 1.5 mm; 10 lines = 27 mm

Date of creation: 1546/47 in Venice (His third numbered Hebrew)

Punchcutter: Guillaume I Le Bé

First occurrence: *She'alot veTeshuvot*, Venice, Giustiniani, 1545?

Le Bé's third type and his second rabbinical Gloss (script) appears in four places in the two documents.

The annotations on NAF 4528 folios 3: folio 14 of 1665 add to our knowledge about Le Bé, and also pose further unanswered questions. The various mentions of May, Maggio or Maz de Parense or Parenza indeed correctly refer to Meir di Parenzo, one of the two Parenzo brothers active as printers and publishers in Venice during the sixteenth century. The British Museum STC of Italian Books lists them as Me'ir ben Jacob (active between 1545 and 1574) and Asher ben Jacob (active between 1579 to 1596) and lists 16 titles attributed to Meir and 11 to Asher.²⁹³ Amram states that 'Meir Parenzo learned his craft in the shop of the prince of printers Daniel Bomberg, where he was associated with Cornelio Adelkind' and also writes that Me'ir father, Rabbi Jacob ibn Parenzo, 'was also a member of the craft'.²⁹⁴ Meir di Parenzo was associated with Marco Antonio Giustiniani, Alvise Bragadin, and Carlo Querini, all members of the Venetian patriciate. His link to Le Bé is clear and we may assume that Meir di Parenzo had some role in making connections to other Venetian printers for whom he worked. Jews were generally not able to function as printers on their own in Venice, yet Parenzo was able to circumvent these restrictions, as he did manage to publish at least four editions under his own imprint and printer's mark (a Hanukiah or Candelabra). He was certainly a skilled printer, publisher and scholar in terms of Jewish texts.

Le Bé then mentions, and not for the last time, his legal dispute with Giustiniani. He calls it a *grand procès* which could indicate that large sums of money or at least an important principle was at stake. The assumption is that either the case arose due to Giustiniani's use of this typeface in the 1546 Talmud and did not reimburse Le Bé appropriately. The clue may lie in the second comment, which tells us that Le Bé did not justify the matrices himself and did not produce a specimen with his name on it as a guarantee of his work.²⁹⁵ Whoever the 'Allemant' was, possibly a competitor engraver or typefounder, Le Bé lost control of his livelihood in this case, and saw no

²⁹³ British Museum Dept. of Printed Books, A. F. Johnson, and Victor Scholderer, *Short-title catalogue of books printed in Italy and of Italian books printed in other countries from 1465 to 1600 now in the British museum* ([S.l.]: British museum, 1958), pp. 906-907.

²⁹⁴ Amram, *The makers of Hebrew books in Italy*, pp. 367-371

²⁹⁵ N'ayant pas justifié ceste lettre pour la fonte, je n'en ay fait d'espreuve, partant mon nom au dessoubz comme aux precedentes, ains cecy est d'un feuillet d'un livre de laditte lettre fondu par un Allemant

other option but a legal case. He may at this point have begun to produce type for other printers in Venice.²⁹⁶

To date no legal document has yet been found in the Venetian archives to provide further details about this case.²⁹⁷ As Le Bé was technically a foreigner in Venice, it might be expected that the case would have come up before one of the special courts dealing with foreigners (*Giudici al Forestier*),²⁹⁸ and this generally was taken to mean non-Venetians. Given the complex nature of the Venetian legal system, it may be necessary to look in all types of civil and criminal cases for such evidence.²⁹⁹

One possible document relating to Le Bé was found from the review of the Duca di Rivoli material in the Venetian State Archives.³⁰⁰ This was a tenancy agreement (*Affitanza*) dated 17 March 1547 and witnessed by one 'Guielmi de Burgundis eduensis diocesis impressor liborum' (William of Burgundy of the Diocese of Autun, a printer of books). The dates are certainly appropriate for Le Bé's stay in Venice, but it is not clear why he would have described himself as a Burgundian, nor indeed as someone coming from the Diocese of Autun. Troyes would have been located in the Province of Sens, and not in Burgundy.³⁰¹ The notarial entry (in Latin) does not appear to provide any additional information about this person.

The size mentioned in this annotation is described as *cursive moyenne*. This is not the smallest of Le Bé's rabbinicals, but it is clearly a useful size for commentary texts, as seen by the number of times it was used by sixteenth-century Italian printers of Hebraica. The x-height is equivalent to a 6pt Didot, a nonpareil or Minion in old English sizes, or to a nonpareille or Mignonne in old French sizes. The discrepancy in the dates on folio 14 of 1665 (i.e. 1546 and 1556) appears to be a simple error on the part of Le Bé, as it is not possible that he could have cut this type in Venice in 1556.

The text on folio 3 itself is an extract from the *Mishnah*, Tractate Avot, Chapter four, a commentary on the Mishnah by Ovadia of Bartenura, the fifteenth-century biblical Rabbi and commentator.³⁰² This specimen is most likely from the *Mishnayot* printed

²⁹⁶ Amram also noted this reference to a court case but could add no more details. He wrote that 'the reason for the suit is unknown and we can only guess at its cause'. Amram, *The makers of Hebrew books in Italy*, p. 371

²⁹⁷ This researcher spent some three weeks in November 2011, sponsored by a grant from the Bibliographical Society of America, with the aim of exploring the Archivio di Stato and other Venetian archives for evidence of Le Bé's period in Venice. No evidence of a court case involving him and Giustiniani was found during this research.

²⁹⁸ Andrea Da Mosto, *L'Archivio di Stato di Venezia: Indice Generale, Storico, Descrittivo ed Analitico* (Roma: Biblioteca d'Arte Editrice, 1937), p. 91 (Vol I)

²⁹⁹ I am indebted to Dr. Renata Segre for her advice on this subject.

³⁰⁰ See page 27 of this thesis.

³⁰¹ Prince d' Essling, Victor, 'Archivio di Stato di Venezia ("Archivietto")', Stampatori, Ricerca Duca di Rivoli', (Venice: Archivio di Stato Venezia, 1901-1904) f. 72v

³⁰² See 'Obadiah (Yareh) Ben Abraham Bertinoro' (<<http://www.jewishencyclopedia.com/articles/3171-bertinoro-obadiah-yareh-b-abraham>> [Accessed 20 June 2011])

in Sabbioneta in 1559, yet the type is identical to the *Mishnayot mi-Seder Torhorot*, printed by Querini in Venice in 1548/49.³⁰³

The complete alphabet and key letter recognition factors

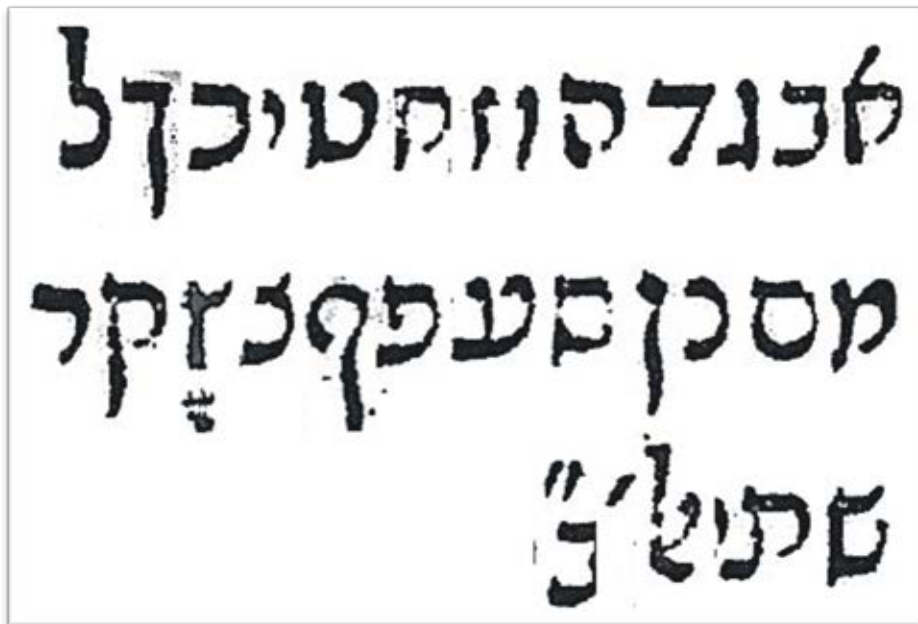

Fig. 2.43: Hb5 (R) Complete assembled alphabet: to approximate appearing size of 10mm



Fig. 2.44: Hb5 (R) Complete assembled alphabet: to actual appearing size of 1.50mm



Aleph: The upper ascender joins almost directly to the left vertical stroke

Bet: The vertical stroke has a swelling to the vertical stroke.

Gimmel: The vertical stroke protrudes below the baseline stroke.

Dalet: The sharply angled junction between the horizontal and vertical stroke articulates this letter against the character resh.

Vav: The left facing termination flag defines this letter.

Zayin: The right facing termination flag defines this letter.

Lamed: The ascender is perpendicular and has a distinct cross stroke termination pointing left. The ascender stroke thickens towards the top.

Final Nun: The termination flag faces left. and is a clear difference to the Bomberg Rashi types.

³⁰³ British Library, *Mishnayot : ... im perush ha-rav Rabenu Mosheh b.R. Maimon ye-im perush ha-rav Ovadyah mi-Bartenurah ...Sabbioneta, 1559. (1950.c.2-3). Mishnayot mi-seder Tohorot, Venice, 1548/59 (1950c1)*



Samekh: The samekh and the shin are very similar in the actual appearing size. The upper horizontal stroke contrasts it to the angled unattached upper stroke in the shin.

Ayin: The base stroke protrudes beyond the left vertical stroke.

Final Tsadde None of the Specimens have an example of this character. This is from the colophon of *Sefer Sha'arei Dura*, Parenzo, Venice 1547. The ascender is probably damaged.

Resh: The curved junction between the upper horizontal stroke and the vertical strokes is the main defining feature as against the dalet.

Shin: The upper angled horizontal stroke defines the shin as against the Samekh.

Tav: Similar to Hb 2 (R) but without the thickened swell in the left vertical stroke.

Aleph/Lamed Ligature. Similar to HB1 (S) but with more of a curved base stroke.

Hb5 (R) was found in the following printed editions during the search of primary material. The earlier attributions (prior to 1546) may indicate a discrepancy in the dates given by Le Bé in his annotation.

- *She'alot veTeshuvot*, Venice, Giustiniani, 1545?
- *Seder tefilot mi-kol ha-shanah*, Venice, 1545
- *Sha'ar bet H. he-hadash: ... Humash im Targum va-Hamesh megilot ve-Haftarot*, Venice, Giustiniani, 1546
- *Babylonian Talmud*, Venice, Giustiniani, 1546/50
- *Pesahim u-khetavim*, Venice, 1546?
- *Sefer HaKuzari*, Venice, Parenzo, 1547
- *Sefer Ha Shorashim*, Venice, Giustiniani, 1547
- *Sefer HaShorashim*, Venice, Giustiniani, 1547
- *Sefer Sha'arei Dura*, Venice, Parenzo, 1547
- *Mishnayot MiSeder Nashim*, Venice, Querini, 1548
- *Hilchot Shehita uVadekah*, Venice, Daniel Adelkind, 1549
- *Sefer Mishal HaKadmoni*, Venice, Parenzo, 1550?
- *Mishneh Torah*, Venice, Bragadin, 1550
- *Mishneh Torah*, Venice, Giustiniani, 1550
- *Hilkhos Shehita uVedikah*, Venice, Adelkind, 1550

- *Sefer Orah Hayim*, Venice, Bragadin, 1563
- *Sefer Ruach Hen*, Cremona, Conti, 1566
- *Sefer Meir Iyov*, Venice, di Cavalli, 1567
- *Shulchan Arukh*, Venice, Giovanni Grypho, 1567?
- *Sefer Kol-Bo*, Venice, di Cavalli, 1567?
- *Machzor*, Venice, di Cavalli, 1568?
- *Mishneh Torah*, Venice, Bragadin, 1574
- Koppelman, *Sefer Misle Su'alim*, Freiburg im Breisgau, Zifroni, 1583
- Gerondi, *Sefer Chaje Olam*, Freiburg im Breisgau, 1583
- Benjamin Tudela, *Masa'ot shel Rabi Benjamin*, Freiburg im Breisgau, Zifroni 1583?
- *Sefer Toledot Aharon*, Freiburg im Breisgau, Zifroni, 1584
- *Bible/Pentateuch*, Venice, Bragadin, 1590
- *Sefer Toledot Aharon*, Venice, Bragadin, 1591
- *Sefer HaKuzari*, Venice, Di Gara, 1594
- *Yalkut HaTorah/Shimeoni*, Cracow, Prostitz, 1595
- *Shnem Asar Derashot*, Venice, Di Gara, 1596
- *Machzor* (Prayer book), Venice, Bragadin and di Gara, 1599
- *Sefer Harukh*, Basel, Waldkirch, 1599
- *She'elot u-Teshovot*, Hanau, Hans Jakob Henne, 1610
- *Arba'ah Turim*, Hanau, Hans Jakob Henne, 1610?
- *Sefer Mishle*, Hamburg, 1698?

Hb6 (S)

Appears on NAF 4528 folios 4 and 6; Rés X 1665, folios 11, 12 and 12v

Size: Petit Texte

Type Classification: Square Sephardic unpointed

Measurements x-height of 2.1 mm; 10 lines = 42 mm

Date and place of creation: 1547/48 Venice Note: 1665/12/54 gives 1547 and 1558 as dates in Venice (His fourth numbered typeface)

Punchcutter: Guillaume I Le Bé for Meir di Parenzo and Carlo Querini

First occurrence: *Hilshot Shehita uVadekah*, Venice, Daniel Adelkind, 1549

NAF 4528 folio 4 contains specimens of three different Hebrew typefaces, of which the first is Hb6(S).³⁰⁴ This is an unpointed Square Sephardic and Le Bé notes in his annotation that he cut it for Meir di Parenzo, and he further adds that he cut two types 'soubz l'adveu du magnifique messer Carlo Quirini, en une maison, size au bout d'une ruelle regardant sur le quay de la Madona de l'Orto'. The word *adveu* in old French may also indicate under contract or agreement and thus probably means that Le Bé was paid by Querini for this work.³⁰⁵

On Rés X 1665, folio 12, which is identical to the first specimen, he makes a similar comment and confirms that the single word is also his design: 'Ce petit texte et glose grosse en ce mot de petit canon sont de mes ouvrages, faitz a Venise, le texte et glose faitz pour Mazo de Parenza comme est cy devant dit, en l'an 1547, les 4e et 5e lettres de mes fassons'.

These notes are instructive in that they provide much detail about Le Bé's contacts and activities in Venice. What these notes tell us is that by 1547 Le Bé had begun to produce types for Meir de Parenzo, possibly due to his dispute with Marco Antonio Giustiniani. It also tells us that he had begun an association with Carlo Querini about 1547.

The four relevant annotations differ in certain details, some of which are contradictory and others which add information to our knowledge about Le Bé. If one examines the first specimen, the first instance of the typeface (NAF 4528 folio 4) is not mentioned at all, whereas in the second (Rés X 1665, folio 12) Le Bé adds 'et ce mot de petit canon'.³⁰⁶ The dates from these two specimens concur in the date 1547. Clearly this specimen, containing his fourth, fifth and eighth typefaces, was produced no earlier than 1547. This specimen is an assembled text dealing with Halakhic rules of Kashrut and the salting of meat.³⁰⁷ The closest model for the text found to date is the 1599 edition of R. Isaac ben Meir Dueren's *Sha'are Dura*, printed by Konrad Waldkirch in Basle in 1599, which uses some of the same Le Bé typefaces. Although the earlier date of the Le Bé specimen and the fact that the first edition was published in Cracow in 1534, this means that it could be a setting taken from various different

³⁰⁴ See page 411 of this thesis for the full specimen.

³⁰⁵ Cotgrave, *A Dictionarie of the French and English tongues*

³⁰⁶ See the complete folio on page 404 of this thesis.

³⁰⁷ The *Halacha* is the collective body of Jewish law and Kashrut is body of Jewish dietary laws.

elements.³⁰⁸ The final line. Le Bé's signature, reads 'BeVenetzhah Gulielmo LeBay Tsarfati'.³⁰⁹

It is curious that in all four examples of this typeface in the two documents there are no instances of pointed setting. This size, petit texte, would seem useful for biblical setting, which would require both vowels and cantillation marks, but the specimens are all of biblical commentaries such as a text on the rules of blessing on food (the Birkat HaMazon) on 4528 folio 6, and the *Mishneh Torah* on 1665 folio 12v. The specimen on 4528 folio 4 appears to be cast on a larger body than those in 1665 folios 11 and 12v, where the body size is slightly tighter (10 lines = 40 mm). This may be due to the need to save space and align the main text with the commentary in Rashi script in a complex Folio layout such as the *Mishneh Torah*. There is nonetheless evidence of some kerned characters, where for example the ascender of the lamed nearly overlaps with the descender of the ayin or final nun (ן). But this typeface appears to pose fewer issues of fit to a compositor than with a completely pointed setting. Le Bé's skills as a punchcutter and his intuitive understanding of the complex requirements of Hebrew setting are what sets him apart from his contemporaries.



Fig. 2.45: Hb6 (S) A detail from the 1550 Bragadin *Mishneh Torah* showing the alignment between the main text and side commentaries. Also note the situations where certain characters would be kerned. Actual size (BL 1918e1)

³⁰⁸ See 'Sha'arei Dura' (<http://www.virtualjudaica.com/Item/21804/Shah%27arei_Dura> [Accessed 05 October 2013])

³⁰⁹ In Venice by Guillaume Le Bé a Frenchman

קצג וכל זמן שאינן ג' מצות להם ליחלק
 דתניא ב' שאכלו מצודה ליחלק
 שיברך כא ברכת המזון לעצמו אבל בברכ' המוציא
 פוטר אחד את חברו במה דברים אמורים כשהיו
 שניהם יודעין לברך ברכת המזון אבל אם אחד יודע
 והשני לא יודע מברך היודע והשני יוצא וכגון
 שמבין לשון הקדש אלא שאינו יודע לברך וצריך
 לבין מלה במלה לכל מה שיאמ' אבל אם אינו מבין
 אינו יוצא בשמיעה ולכך אין הנשים יוצאות בשמיע'
 אם אינן מבינות אבל כשהן שלשה אין רשאי ליחלק
 כרתנן שלשה שאכלו כאחת אינן רשאים ליחלק ולא
 עוד אלא אפילו שנים שאכלו כאחת מצודה שיחזור
 אחר שלישי שיצטרף עמהם לזימון וכן ארבע או
 חמשה אסור להם ליחלק שכולם נתחייבו בזימון
 ששה נחלקין כיון שישאר זימון לכל חבר' עד עשרה
 ואז אין נחלקין כיון שנתחייבו בהזכרת השם עד
 עשרים ומצוה לחזור אחר עשרה ומיהו אם היתה
 חבר' גדולה מסובין יחד ואינן יכולין לשמוע הכרכ'
 מפי המברך ואינן רשאים ליחלק לחבור' של עשרת
 עשרה מפני שיצטרכו לברך בקול רם וישמע בעל

Fig. 2.46: Hb6(S) 20 line specimen from *Arba'ah Turim*, printed by Alvise Bragadin, Venice 1563, p. 122. This same specimen appears in part in NAF 4528, f. 6 (BL, 1920b6)

The complete alphabet and key letter recognition factors

א א ב ג ד ה ו
 ז ח י כך ל מ ס ס
 ז ס ע פ פ צ צ ק ר ש
 ת ט

Fig. 2.47: Hb6 (S) Complete assembled alphabet enlarged to 10 mm x-height

א א ב ג ד ה ו ז ח י כך ל מ ס ס ז ס ע פ פ צ צ ק ר ש ת ט

Fig. 2.48: Hb6 (S) Complete assembled alphabet actual size of 2.1 mm x-height

This typeface follows very much in the pattern of his first and second Square Sephardic Hebrews, and three distinctive elements can be noted: the termination stroke on the ascender of the lamed has a very pronounced oblique serif-like form

pointing left, the middle stroke of the shin joins to left hand side stroke, and the termination to the ascender of the Aleph/Lamed Ligature is horizontal and is closer to a Roman serif.

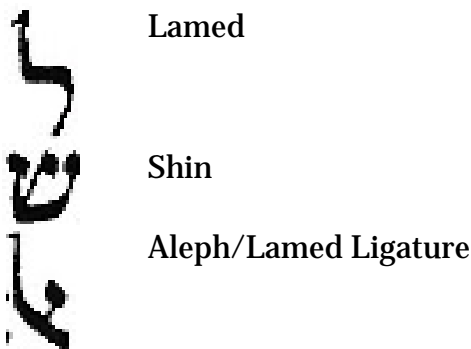

This typeface was found in the following editions dating from 1549 to 1599.

- *Hilchot Shehita uVadekah*, Venice, Daniel Adelkind, 1549
- *Hazeruni*, Cremona, Conti, 1559?
- *Sefer Orah Hayim* (Part of the *Arba'ah Turim*) Venice, Bragadin, 1563
- *Arba'ah Turim*, Venice, Giovanni Grypho, 1564
- *Yalkut haTorah*, Venice, 1566
- *Shulchan Arukh*, Venice, Giovanni Grypho, 1567
- *Mishneh Torah*, Bragadin, Venice, 1574
- *Sefer Kavanot HaAggadot*, Basel, Ambrosius Frobenius/Zifroni, 1580
- Koppelman, *Targum shel Chamesh Megilot*, Freiburg im Breisgau, Zifroni, 1584?
- *Sefer Mikrae Kodesh*, Venice, Bragadin and Parenzo, 1586?
- *Sefer She'eolot uTeshuvot*, Venice, Di Gara, 1586/7
- *Sefer Toledot Aharon*, Bragadin, Venice, 1591
- *Yalkut HaTorah*, Prostitz, Cracow, 1995/96?
- Hugh Broughton, *Epistolae variae et variarum linguarum, de Byzantiacis hebraeis ...*, Waldkirch, Basel, 1599
- *Sefer Harukh*, Waldkirch, Basel, 1599
- *Psalmus Primus cum Commentarijs*, Paris, Guillaume II Le Bé, 1612

Hb7 (R)

Appears on NAF 4528 folio 4, Rés X 1665, folios 11, 12, 12v and 21v

Size: Grosse Glose

Type Classification: Rabbinical (Rashi) unpointed

Measurements: x-height of 2 mm; 20 lines = 89 mm

Date and place of creation: 1547 in Venice (his fifth numbered typeface)

Punchcutter: Guillaume I Le Bé for Meir di Parenzo

First occurrence: *Mishneh Torah*, Bragadin, Venice, 1550

This is Le Bé's fifth typeface and his third Rabbinical in this document. It is virtually identical in appearing size and leading to Hb2(R), and yet different enough in its details to make it a distinct typeface, and one which we can clearly attribute to Le Bé. A comparison between the two typefaces at an enlarged appearing height is instructive:

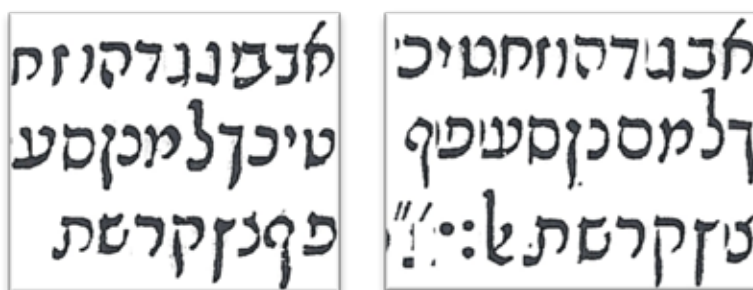

Fig. 2.49: Hb2 (R) (left) and Hb7 (R) (right) compared at 5 mm appearing size.

The complete alphabet and key letter recognition factors



Fig. 2.50: Hb7 (R) complete alphabet at actual appearing size of 2.00 mm

Hb7 (R) is on the whole cut with a much more attention to detail, with a slightly larger 'oeil'³¹⁰ and a more 'cursive' feel. The particular differences in individual characters are as follows.



Aleph: The counter is larger and the right hand stroke not as close to the left hand vertical.

Bet: The base stroke is rounder and longer.

³¹⁰ Christian Paput defines Oeil as 'la surface graphique de la lettre. See Paput, *La lettre/La Gravure du Poinçon typographique* p. 19. The term does not always correspond with the term x-height, as can be seen from the following definition: 'Il s'agit traditionnellement de la hauteur de la lettre minuscule x. L'œil désigne également la hauteur des lettres bas de casse d'une police de caractères, sans les hampes ascendantes et descendantes. Certaines lettres bas de casse sans hampe ascendante ni descendante ne correspondent néanmoins pas tout à fait à cette hauteur d'œil. La hauteur d'œil peut varier considérablement d'une police de caractères à l'autre, pour un corps donné.' I am using it here to indicate appearing size. See 'Glossaire de termes typographiques' (<<http://www.adobe.com/fr/type/topics/glossary.html>> [Accessed 03 July 2011])



Gimmel: The base line stroke is more swelled and joins higher up on the vertical stroke.

Final Kapf: The vertical down stroke has a decided angle to the right.

Lamed: The bowl of the lower stroke is more open and has a more right-angled join to the upstroke.

Nun: Shorter in extent and more semi-circular in shape than in Hb2(R).

Final nun: The termination of the descender is more pointed.

Samekh: The counter is larger and the down strokes more vertical.

Ayin: The terminations in the two vertical strokes are more rounded and point downwards.

Tsadde: The termination is longer and more angled.

Koph: The down stroke is straighter.

Tav: The left down stroke is longer and protrudes below the x-height.



Fig. 2.51: Hb7 (S) Specimen at actual appearing size of 2 mm from NAF 4528. f.4

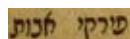

Fig. 2.52: Hb7 (S) Specimen at actual appearing size of 2 mm from NAF 4528. f.9v

The mention of Carlo Querini (or Quirini) in the annotation is the first mention of his name and one that needs some explanation. Given the prohibitions enacted by the Venetian Senate against Jews engaging in or printing or publishing books in Venice, Jewish printers such as Meir di Parenzo sought the protection of Christian patrons –

usually members of the Patrician class. The first notable prohibition was enacted in December 1571 and set out that 'no Jew may work at the press or publish books under penalty of confiscation of the goods and payment of one hundred ducats. And those who have published under the name of Christians shall incur the same penalty and the printed books will be considered to belong to those in whose name they have been published'.³¹¹ There were in fact earlier prohibitions, which did not necessarily mention Jews, but the establishment of the guild of printers in January 1549 certainly would not have envisaged admitting Jews to its membership.³¹²

Carlo Querini does not appear to have had any prior connection with printing, and his reputation was more likely to have been gained in various wars or to have had some high position such as the Podestà di Murano (chief magistrate). And indeed the text surrounding Querini's printer's mark reads in Hebrew with typical Renaissance hyperbole, 'he who sits in a golden chariot is Carlo Querini, who commands armies and is considered a hero'.³¹³ There was in fact a Carlo Querini who was born in 1516 and died in 1567 and a member of the Delle Papozzi Branch of this family.³¹⁴ It is not likely that he was a member of the branch of the Querini family which founded the Fondazione Querini Stampalia in Venice.³¹⁵ The Chiesa Madonna dell'Orto and the quayside of the same name mentioned in the annotation is situated – Le Bé probably meant the present day Fondamenta Madonna dell'Orto – on the very north side of the Sestiere of Cannaregio, north of the Ghetto Nuovo. This is Le Bé's second address in Venice.

The association of Meir di Parenzo and Carlo Querini produced some six imprints between the years 1547 and 1550, using Querini's printer's mark of an ornate framed mirror with three stars in the centre or Parenzo's mark of a seven-branched Jewish menorah or candelabrum.³¹⁶ This may have been the end of Parenzo's association

³¹¹ Brown, *The Venetian Printing Press*, p. 106 The original text in Italian reads: non possa alcun hebreola vorar di stampa ne far stampare libri, et contrafacendo incorrino in pena di perder la robba et pagar ducati cento. Et quelli che facessero stampar sotto nome de Christiani incorrino nell istessa pena et li libri stampati si intendano esser et siano di colui in nome de chi fussero stati stampati.

³¹² Benjamin Ravid, 'The Prohibition against Jewish Printing and Publishing in Venice and the Difficulties of Leone Modena', in *Studies in medieval Jewish history and literature (Harvard Judaic monographs; 2)*, ed. by Isadore Twersky (Cambridge, Mass. ; London: Harvard University Press, 1979), p. 138. See also Nuovo, *The Book Trade in the Italian Renaissance*, p. 217

³¹³ I am indebted to Dr. Dorit Raines of the University Ca' Foscari in Venice for this information, via Dr. Professore Mario Infelise of the same of the same university. (Email communication March 2010)

³¹⁴ Marco Barbaro, '*Arbori de' patritii Veneti*', (Venice: Archivio di Stato, 1743), p. 320 (Vol. VI/No. 328)

³¹⁵ I am grateful to the librarian of the Fondazione Querini Stampalia, Signora Cristina Celegon for this clarification.

³¹⁶ 'Parenzo worked for some time as a typesetter and corrector at the press owned by Carlo Querini. During 1546-48 he worked on his own, publishing five works, and later an edition of the *Mishnah* with Bertinoro's commentary for Querini, although from about 1550 his main work was with Alvise Bragadin.' See

'Parenzo'(<http://www.jewishvirtuallibrary.org/jsourc/judaica/ejud_0002_0015_0_15420.html> [Accessed 03 July 2011])

with Querini, but not so for Le Bé, who dedicated two specimens to him from Paris in 1579 (NAF 4528 folios 11v and 2v).



Fig. 2.53: (Left) Printer's mark used on Meir di Parenzo's edition of *Sefer HaKuzari*, Venice, 1547 and (Right) Printer's mark used on the Meir di Parenzo/Carlo Querini edition of *Mishnayot MeSeder Kodashim*, Venice, 1549. Both Reduced 60 per cent (BL 1932d10 and 1950c1)

Despite the annotations by Le Bé regarding the origins of this typeface, it does not appear in the editions printed by Meir di Parenzo or Carlo Querini in the second half of the 1540s. The first occurrence found to date is in the two competing editions of the *Mishneh Torah* by Giustiniani and Bragadin in 1550. Why this should be so is a mystery, and it has to be admitted that our understanding of the working arrangements in Renaissance print shops are extremely vague, unless more original documents come to light which throw more light on them. Bernard Cooperman has studied four Hebrew editions printed in Rome in the 1540s by Samuel Tsarfati, who was in a partnership with the Roman printer Antonio Blado. Cooperman writes that 'on the title pages and in the introductions to these books (produced by Marco Antonio Giustiniani) the Jews present themselves as merely carrying out the commissions of their patrons, but one suspects that such declarations were no more than *pro forma* efforts to satisfy the licensing authorities'. He adds: 'these Jews, I suspect, were clearly entrepreneurs rather than employees'.³¹⁷ Meir di Parenzo is a good example of this type of collaboration within the protection of a Christian

³¹⁷ Cooperman, 'Organizing Knowledge for the Jewish market: An editor/printer in Sixteenth-century Rome', p. 27

patron, as well as a printer/publisher who was able to publish edition under his own name.

Given the difficulties that Jews had in obtaining 'privilegi' (approval to print) from the Venetian Senate, it is not surprising that no Hebrew publications appear in the lists of senatorial copyrights compiled by Horatio Brown for the period 1527 to 1555.³¹⁸ This may explain why the names of Jewish printers do appear in the records of the *Esecutori contra la Bestemmia*, the Venetian body charged with overseeing heretics and supervising the publication of prohibited books. Many Jews did print 'senza licenzia' (without permission), knowing that once published they would escape with relatively minor penalties.³¹⁹

Attributions for this typeface in printed editions:

- *Mishneh Torah*, Bragadin, Venice, 1550
- *Mishneh Torah*, Venice, Giustiniani, 1550
- *Sefer Behinat Olam*, Ferrara, 1551
- *Sefer Likute shikheah u-feah*, Ferrara, 1556
- *Sefer Toledot Yitzhak*, Mantua, 1558?
- *Maharil*, Cremona, Conti, 1558?
- *Arba'ah Turim*, Giovanni Grypho, Venice, 1564
- *Shulhan Arukh*, Bragadin, Venice, 1565
- David ben Joseph Abudarham, *Leperush Tefilot HaShana*, Venice, Di Cavalli, 1566?
- *Shulhan Arukh*, Venice, di Cavalli, 1567
- *Shulchan Arukh*, Venice, Giovanni Grypho, 1567
- *Sefer Haguda*, Prostitz, Cracow, 1571?
- *Sefer Neim Zemiroth*, Prostitz, Cracow, 1576
- *Bible*, Antwerp, Plantin, 1573
- *Sefer Sha'arei Dimah*, Di Gara and Bragadin, Venice, 1586
- *Sefer She'eolot uTeshuvot*, Di Gara, Venice, 1586/7
- *Sefer Derash Mosheh*, Prostitz, Cracow, 1589
- *Mateh Mosheh*, Prostitz, Cracow, 1591?
- *Sefer Toledot Yitzhak*, Prostitz, Cracow, 1593?

³¹⁸ Schedario di Horatio Brown, Privilegi veneziani per la stampa 1527 – 1597, Biblioteca Nazionale Marciana, Venice, IT. VII 2500-2502 (12077-12079) Bundles A and B

³¹⁹ For example, in the records of the Esecutori contra la Bestemmia, Terminazioni 1542-1560, Busta 56, Archivio di Stato, Venezia. See also Nuovo, *The Book Trade in the Italian Renaissance*, pp. 195-257

- *Minhah BeLulah*, Francesco delle Donne, Verona, 1594
- *Yalkut HaTorah*, Prostitz, Cracow, 1595/96
- *Sefer Tana Divrei Eliahu*, Zanetti, Venice, 1598?
- *Sefer Tiferet Israel*, Zanetti, Venice, 1599

Hb8 (R)

Appears on NAF 4528 folio 5

Size: Petite glose or Petite cursive

Type Classification: Rabbinical (Rashi) unpointed

Measurements: x-height of 1.1 mm

Date and place of creation: 1548 (his sixth numbered typeface) in Venice

Punchcutter: Guillaume I Le Bé for Meir di Parenzo

First occurrence: *Sefer Ha Shorashim*, Venice, Giustiniani, 1547

Le Bé's commentary to this short specimen gives two names for this typeface, neither of which, Petite glose or Petite cursive, relates to any known type size. It is slightly larger in appearing size to Hb18 (R), which is 1.0 mm, and the same size as Hb 15 (S) which Vervliet lists in his *Conspectus* as Le Bé's Mignon Hebrew (Heb. 1.1).³²⁰ This is thus the earliest attempt made by Le Bé to cut a small Hebrew in a size of Mignon (old English) or Mignonne (old French) and may have influenced Plantin in his request of 1569 to ask Le Bé 'de la fayre la plus petite que je pourroye'.³²¹ The resulting typeface Hb 15 (S) which survives in the MPM is MA 83 Coronelle Hebrew, which in fact is the Dutch name for Minion and is equal to 6pt Didot.³²²

No smaller Hebrew exists in Vervliet's *Conspectus* and it would have been a mark of skill for a punchcutter to be able to engrave such a small typeface.

The location given in the annotation is off the Campo San Lio in the sestiere of Castello, the third address for Le Bé in Venice and is within easy walking distance of the Rialto. The monthly rent given is also of interest, and probably indicates that Le Bé was not particularly well paid for his type, if one takes into account that 'a compositor might hope to earn 50 or 60 ducats a year' and that he had to pay for materials such as steel for punches, copper for matrices etc.³²³ Le Bé's three moves in Venice indicate that he was *not* operating a typefoundry, which would have required much heavier equipment such as some kind of furnace to produce the type metal or the punches and counter punches and that he was thus able to move about with the modicum of equipment – for example files, gravers, gauges, and smoke proofer – to produce his punches.³²⁴

The amount of equipment and space required for a fully operative typefoundry can be judged from the following details of the Enschedé typefoundry in Haarlem, from the 1768 catalogue. The detail on the left shows three casting 'stations', with three workers casting per furnace. The right hand detail shows the type of finishing

³²⁰ Vervliet, *French Renaissance Printing Types: A Conspectus*, p. 389

³²¹ NAF 4528 folio 12 annotation.

³²² Voet, *The Golden Compasses*, p. 56 (Vol 52)

³²³ Brian Richardson, *Printing, writers, and readers in Renaissance Italy* (Cambridge: Cambridge University Press, 1999), p. 25

³²⁴ For images of an operating typefoundry see Plate II in *Fournier on Typefounding* or Plate I in *l'Encyclopedie* in the section of printing. For a description of the basic tools required to cut punches see Paput, *La lettre/La Gravure du Poinçon typographique* pp. 18-21. See also Appendix K with Harry Carter's more recent list of typefounder's tools.

operations such as rubbing, dressing and kerning as described by Moxon.³²⁵ In addition, the dangers from fires due to furnaces were a continual risk in Venice, as can be seen in the compulsory removal of all the glass furnaces to the island of Murano in the thirteenth century.³²⁶



Fig. 2.54: Details of the typefoundry from the *Proef van letteren: welke gegooten worden in de nieuwe Haerlemsche lettergieterij van J. Enschedé*. 1768. (The UB Frankfurt / StUB Frankfurt am Main HM 6: Em 9.)

The phrase used by Le Bé ‘taillé et gravé’ in the annotation raises the question once again if Le Bé intended a different action in these two words. In Fournier’s *Manuel Typographique* both terms are used as in ‘l’art de graver les caractères’ or graver des poinçons, ‘tailler sur une lame d’acier deux pointes distantes de la largeur juste’, or ‘tailler avec la lime les figures marquées ci-après’. These are the terms Le Bé uses most of the time and it is fair to assume that he was indicating two distinct processes.³²⁷

The text itself has the heading ‘Rabbi Eliezer said’, which could refer to the first century Biblical commentator Rabbi Eliezer ben Hyrcanus, but the following lines are similar to the specimen in NAF 4528 folio 9v, which is from the *Mishnah*, Tractate Avot, Chapter Heh (6). The penultimate line is a series of random letters, mainly to demonstrate the final kapf (ך), peh and Tsadde. The final line reads *BeVenetzia Gulielmo LeBay Tsarfati* (In Venice Guillaume Le Bé Frenchman).

³²⁵ See Moxon, Carter, and Davis, *Mechanick Exercises*, pp. 168-190

³²⁶ See Jan Morris, *Venice* (London: Faber and Faber, 1993), pp. 266-267

³²⁷ See Fournier and André, ‘Lettres polémiques sur la typographie’. See also page 57 of this thesis for a fuller discussion.

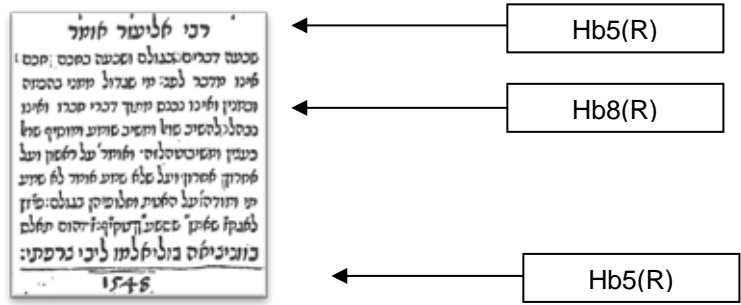

Fig. 2.55: Hb8 (R) Specimen at actual size from NAF 4528 f.5

The complete alphabet and key letter recognition factors



Fig. 2.56: Hb8 (R) assembled alphabet enlarged to approximate x-height of 10 mm



Fig. 2.57: Hb8 (R) assembled alphabet at actual size of 1.1 mm

Le Bé's rabbinical typefaces, as previously mentioned, are very difficult to attribute absolutely, given the distortion of ink squash and the small number of characters to compare in many printed editions. The earliest likely use of this typeface is with Giustiniani in 1547, and a very possible use for superscript references in the *Mishneh Torah* of 1550. It does not appear in any of the Parenzo editions examined for the relevant period.

- *Sefer Ha Shorashim*, Venice, Giustiniani, 1547
- *Mishneh Torah*, Venice, Giustiniani, 1550
- *Sefer Tana Devrei Eliahu*, Venice, Zanetti, 1598?

Hb9 (S)

Appears on NAF 4528 folio 6, Rés X 1665, folios 14, 17v and 18

Size: Texte du Talmuth

Type Classification: Square Sephardic unpointed

Measurements: x-height of 3.1 mm

Date of creation: 1549 in Venice (his seventh numbered typeface)

Punchcutter: Guillaume I Le Bé for Meir di Parenzo

First Appearance: *Mishneh Torah*, Bragadin, Venice, 1550

The specimen in which this typeface appears is from an edition printed in Venice in 1563 entitled *Sefer Orah Hayim*, by Jacob ben Asher, a thirteenth century Ashkenazic codifier and Biblical commentator,³²⁸ and this work is a commentary on the ritual laws relating to the daily prayers, the Sabbath, and holy days.³²⁹ This edition was printed by Alvise Bragadin, who used Arabic page numeration in addition to the Hebrew 'numbers'.³³⁰ The text on this page is a discussion of the Laws of the *Birkat Mazon* or the laws relating to the blessings and prayers recited before eating. The actual page consists of two specimens pasted down in the document, with the main body from *Sefer Orah Hayim* and a smaller bit containing the words *Migdal Oz* – a commentary on Maimonides by the thirteenth century Spanish Talmudist and cabalist Shem-Tov ben Avraham ibn Gaon.³³¹ The relevant words are underlined in red, presumably by Le Bé to show which letters he had cut.

In his annotation Le Bé tells us that this typeface was cut for Meir di Parenzo, which implies that di Parenzo was associated in some way with Bragadin at this time, whether as an editor, printer or compositor. It also tells us that Le Bé did not obtain a proof with his name set into the text, his usual practice, and that he obtained this specimen long after his return to Paris in 1550. It thus gives indirect evidence of his continuing contacts with Italy, which is seen in the dedications to Carlo Querini in the type specimens on folios 11v and 12v of NAF 4521. He also tells us that the type was cut 'en maditte chambre', which presumably was his third residence in Venice near to the Campo S. Lio.

The final comment in the annotation concerns Le Bé's six month stay of in Rome during the Papal Jubilee of 1550 and is the only mention of this event in his annotations. It is mentioned once again in the *Le Bé Memorandum*, where Guillaume II Le Bé writes of this father that 'apres cela fut à Rome à la Solennité de lan 1550 soubz le pape Iules, ce que ayant veu et assisté ...'³³² Le Bé tells us that he stayed with the printer Antonio Blado, 'imprimeur de la Chambre Apostolique'.

³²⁸ Christian D. Ginsburg, *Introduction to the Massoretico-critical edition of the Hebrew Bible* (New York: Ktav Publishing House, 1966), p. 122 (British Library 1920.b.6)

³²⁹ See 'Aaron Ben Moses Ben Asher'(<<http://www.jewishencyclopedia.com/articles/2857-ben-asher>> [Accessed 07 July 2011])

³³⁰ This type of pagination was also used by Giustiniani, for example in his *Sefer Orah Hayim*, printed in 1550. (BL 1920d7 and 8)

³³¹ See 'Shem-Tov ben Avraham ibn Gaon'(<<http://www.jewishencyclopedia.com/articles/13543-shem-tob-ben-abraham-ibn-gaon>> [Accessed 07 July 2011])

³³² Le Bé, *The Le Bé memorandum*, p. 21

Antonio Blado was active as a printer and publisher, mainly in Rome, from 1516 to his death in 1567. He was named printer to the Apostolic Chamber (*Camera Apostolica*) from 1535, and this privilege was passed on to his son Paolo. His total number of publications is thought to exceed 3000, and these cover a wide range of texts, Greek, classical, patristic, and Italian literature, in addition to his work for the Vatican printing edicts and proclamations. He also printed various editions of the classic sixteenth-century calligraphic specimen books of Ugo da Carpi, Giovanni Battista Palatino and Giovanni Francesco Cresci. His Hebrew editions are limited to the years 1545 to 1547, and seven are known.³³³ Blado's name is listed in at least some of these editions as a partner (*Shutaf* in Hebrew) together with Isaac de Lattes and Benjamin d'Arignano. It thus seems that Blado supplied printing services and 'his name on the title page was certainly there at least in part to legitimize a legally problematic endeavor'.³³⁴

The dates of Blado's Hebrew editions and Le Bé's stay in Rome suggest more of a business relationship than is hinted at in Le Bé's annotation. The Papal Jubilee opened in February 1550 and would have lasted until 'the Christmas Eve of the current year'.³³⁵ A visit to this event as a purely religious tourist would not have required a stay of six months, whereas this might have been sufficient time to complete a Hebrew fount.³³⁶ This is a working hypothesis, as Le Bé makes no mention of any typefaces cut for Blado, nor do the lists of Blado's output show any obvious Hebrew works where they might have been used.³³⁷ It is possible that Blado could have had in mind Roman fount, just as Le Bé had previously supplied to

³³³ Marco Menato, Ennio Sandal, and Giuseppina Zappella, *Dizionario dei tipografi e degli editori italiani. Il Cinquecento* (Milano: Editrice Bibliografica, 1997), pp. 147-149

³³⁴ Cooperman, 'Organizing Knowledge for the Jewish market: An editor/printer in Sixteenth-century Rome', in *Perspectives on the Hebraic book: the Myron M. Weinstein memorial lectures at the Library of Congress*, ed. by Weinstein and Pearlstein (Washington, D.C.: Library of Congress, 2012), pp. 28-29

³³⁵ Ludwig Pastor and Frederick Ignatius Antrobus, *The history of the Popes: from the close of the middle ages, drawn from the secret archives of the Vatican and other original sources*. 4th ed. ([S.l.]: Kegan Paul, Trench, Trubner, 1923), p. 56 (Vol. XIII)

³³⁶ Fred Smeijers has estimated that two months would be required to engrave a complete Roman fount at the rate of four punches per day. See Smeijers, *Counterpunch*, p. 124. This appears to fit with the time given by Henri du Tour le jeune to Plantin in 1576 for the compleye work involved in the making of a fount. He wrote: 'Il y fault 3. mois a la taille, 2. sepmaines a la justification, 2. sepmaines aux moules et aultre preparation d'acher et de cuyvre qui font 4. mois. Avec la besoigne qui se pourroit entremesler cependant, vous ne pouvez prendre moins de un demy an. Et il coustera bien 150. fl. devant que pourrez penser a la fonte, ou la environ'. See Christoffel Plantin, Jean Denucé, and Max Rooses, *Correspondance de Christophe Plantin. Publiée par M Rooses, Jan Denucé, [Maatschappij der Antwerpsche Bibliophilen. Uitgaven. no. 12, 15, 26, 29-34, etc.]*Antwerpen; Gent, 1883), pp. 119-120 (Vol. V)

³³⁷ See Domenico Bernoni, *Dei Torresani, Blado e Ragazzoni: celebri stampatori a Venezia e Roma nel XV e XVI secolo, cogli elenchi annotati delle rispettive edizioni* (Farnborough: [Germany Printed], 1968) and Emanuele Biblioteca Nazionale Centrale Vittorio et al., *Catalogo delle edizioni romane di Antonio Blado Asolano ed eredi, 1516-1593, possedute dalla Biblioteca Nazionale Centrale Vittorio Emanuele di Roma ... Compilato da Giuseppe Fumagalli ... e Giacomo Belli, etc. (fasc. 3. Compilato da Emerenziana Vaccaro-Sofia.)*3 fasc. pp. 311. Roma, 1891, 1942)

Lorenzo Turentin (Lorenzo Torentino) in Florence and to Tomaso Jontha (Giunti) in Venice in the years 1546 and 1547, when he was still in Venice.³³⁸

A further suggestion of the links between Venice and Rome is contained in the correspondence between Cornelio Adel Kind in Venice and the humanist scholar Andreas Masius in Rome in May 1547. Adel Kind writes about 'mei padroni bombergi' and mentions 'uno ebreo amico deli bombergi e mio in particolare che a nome biniamin de iosef de arimanio e qual M. gulielmo lo cognosce bene'. The 'iosef de arimanio' is most certainly the Benjamin d'Arignano mentioned earlier as involved with Antonio Blado in the printing of the *Sefer Igeret HaKodesh* in Rome in 1546, and the M. gulielmo refers to the Hebraist and scholar Guillaume Postel.³³⁹ From these personal connections one can easily see how Le Bé might have been recommended by Adel Kind to Blado as a craftsman useful to his press and publications. His trip to Rome, whatever its purpose, does not appear to have brought any long-lasting benefits.

Le Bé's annotation also provides further circumstantial evidence as to his working practices. He appears to have provided strikes or justified matrices to Meir di Parenzo, who then had them cast after Le Bé had departed for Rome. As we have no record of Le Bé returning to Venice, he most probably left behind his working materials, whether they were punches or matrices. The first appearance in the Bragadin *Mishneh Torah* of 1550 would confirm this point.



Fig. 2.58: Hb9 (S) Specimens from NAF 4528 folio 6 (actual size)

³³⁸ See NAF 4528, annotation on f.. 20

³³⁹ Joseph Perles, *Beiträge zur Geschichte der hebräischen und aramäischen Studien* (München: Theodor Ackermann, 1884), p. 209

The complete alphabet and key letter recognition factors



Fig. 2.59: Hb9 (S) assembled alphabet enlarged to 10 mm (additional characters taken from the *Mishneh Torah*, Bragadin, Venice, 1550)

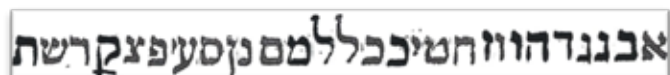

Fig. 2.60: Hb9 (S) assembled alphabet at actual size of 3.1 mm

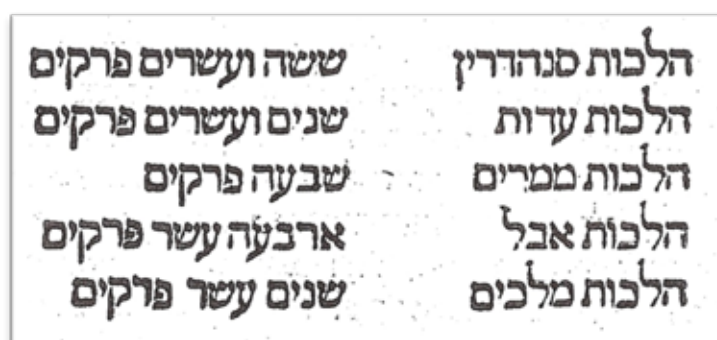

Fig. 2.61: Hb9 (S) from the *Mishneh Torah*, Bragadin, Venice, 1550 (BL 1918e3)

The name Le Bé gives to this typeface, *Texte du Talmuth*, is the same as given to Hb1 (S), yet has less to do with size than with style of character. Given the few occurrences of this typeface that were found and its relative large appearing size, it appears to have been intended for headings and display setting, not for running text. It falls between Vervliet's No. Hb2.5 (Great Primer) and Hb4 (two Line Pica), and thus would probably be Gros Romain in size according to the old French sizes.

- *Mishneh Torah*, Venice Bragadin, 1550
- *Sefer Orah Hayim*, Venice Bragadin, 1563

Hb10 (S)

Appears on NAF 4528 folios 4 and 7; Rés X 1665, folios 3 and 12

Size: Grosse lettre and Petit Canon

Type Classification: Sephardic Square Hebrew Unpointed and pointed

Measurements x-height of 4 mm; 20:177mm (on BL ORB 30/17); 10:88 (on NAF 4528 f. 7)

Date and place of creation: 1548/49 (his eighth numbered typeface)

Punchcutter: Guillaume I Le Bé in Venice

First occurrence: *Mishneh Torah*, Venice, Giustiniani, 1550

This typeface, Hb10(S), appears in four instances in the two documents, twice in the same specimen in NAF 4528 folio 4 and Rés X 1665, folio 12, and twice in a different specimen in NAF 4528 folio 7 and Rés X 1665, folio 3. The first specimen contains only three characters bet, shin and resh (בִּשְׁרֵי), and is used solely in a heading to a text. The second specimen contains a much longer text, but is not complete in terms of showing all the characters in the typeface.

The four relevant annotations differ in certain details, some of which are inconsistent and others which add information to our knowledge about Le Bé. If one examines the first specimen, the first instance of the fount (NAF 4528 folio 4) is not mentioned at all, whereas in the second (Rés X 1665, folio 12) Le Bé adds 'et ce mot de petit canon'. The dates from these two specimens concur in 1547. Clearly this specimen, containing his fourth, fifth and eighth founts, was produced no earlier than 1547. This first specimen is a text dealing with Halakhic rules of Kashrut and the salting of meat and is most probably from the *Mishneh Torah*, although it also could be a setting taken from various different elements.³⁴⁰

The mention of the size, Petit Canon, is the first instance where Le Bé uses what is a recognizable old French size. This is equivalent to two line English, or 26.5 points in Didot points.³⁴¹ Fertel lists this size as being equivalent to two body sizes of Saint Augustin, and lists it as the sixth largest out of 19 body sizes.³⁴² The 20 line count from Bragadin and di Gara's *Machzor* (Prayer book) of 1599 places it within the next size down, Palestine, which demonstrates the difficulty in attributing absolute sizes for this period. The equivalent sized in millimetres given by Bauer (10.526 mm) is in fact very close to the body size from the second specimen.

The second specimen is a text composed of various verses from Proverbs 16 and 22, and not in any particular order. The heading reads 'Yehi HaMelekh' which translates as 'Long live the King'. The penultimate and final lines once again reads *BeVeneziah Gulielmo LeBay Tsarfati/ In Venice Guillaume Le Bé Frenchman*. On Rés X 1665 f. 3: Le Bé notes 'Ceste grosse lettre de ma fasson, faicte a Venise, en l'an 1548, sur

³⁴⁰ See the glossary for more detailed description.

³⁴¹ Vervliet, *French Renaissance Printing Types: A Conspectus*, p. 52

³⁴² Martin Dominique Fertel, *La science pratique de l'imprimerie. Contenant des instructions très-faciles pour se perfectionner dans cet art. On y trouvera une description de toutes les pieces dont une presse est construite ... avec une methode ... pour imposer toutes sortes d'impositions, etc* (Saint Omer, 1723), p. 2

l'eschantillon de ma precedente, taillé pour moy; et celui a qui je laissay mesdits poinsons en garde en a fait des frappes et tout mange, ayant vendue et poinsons et matrice a ung Allemant ainsi que de Dansi [Dantzig?] m'ont mandé'.³⁴³ On NAF 4528 F. 7: he notes 'Ceste lettre est une lettre nommée en l'imprimerie petit canon, taillé a Venise pour moy, en l'an 1548 et 49, et justifié quant et quant les lettres de Mazo, et a esté cy taillé avant la precedente du texte d'un Talmuth pour ledit Mazo'.³⁴⁴

The first comment, 'sur l'eschantillon de ma precedente' most likely means that it based on Hb26 (S) from the previous numbered folio, which Le Bé says came from Constantinople, and is in fact very close in detail and size to Hb10 (S). This comment gives us some idea of Le Bé's *modus operandi*, in that he also used specimens from other types as models for his own. The continuation of the comment relates that he had left the punches for this typeface with an unscrupulous individual, who promptly produced strikes, having stolen (mangé) everything, and then sold the matrices and punches to a German possibly from Dantzig. In the annotation on NAF 4528, folio 7, Le Bé makes no mention of this mishap, and only relates that they were justified according to the characters of Mazo (Meir di Parenzo). It is difficult to reconcile these two accounts, as this typeface does not appear to have been used by Meir di Parenzo in any of the editions accredited to him. It does underscore the problems Le Bé had in keeping control over his type, particularly early in his career. It also points to the very international nature of printing in Venice in the sixteenth century, where printers of many nationalities were attracted to work there, such as Daniel Bomberg from Antwerp or the printer Pietro Lichtenstein and heirs from Cologne.³⁴⁵

Notwithstanding these comments, the first recorded use of this typeface found in this sampling appears in Giustiniani's *Mishneh Torah* in 1550.

³⁴³ This large character of my making, cut in Venice in the year 1548, based on my previous [character?], and cut for me. And the person to whom I left my punches in safe keeping made of them matrices and stole everything, having sold both punches and matrices to a German from Dantzig [?] which were sent to me [?].

³⁴⁴ This character is called small canon by printers and was cut in Venice by me in the years 1548 and 1549 and justified according to [?] the characters of Meir di Parenzo, and was cut before the previous text for the Talmud for the same Meir di Parenzo.

³⁴⁵ See Fernanda Ascarelli and Marco Menato, *La tipografia del '500 in Italia* (Firenze: Olschki, 1989), pp. 332-333, 357-358

The complete alphabet and key letter recognition factors



Fig. 2.62: Hb10 (S) Complete assembled alphabet to enlarged x-height of size of 10 mm. From Le Bé specimen and Machzor (Prayer book), Bragadin and di Gara, Venice, 1599.



Fig. 2.63: Hb10 (S) Complete assembled alphabet at actual size of 4 mm x-height. From Le Bé specimen and Machzor (Prayer book), Bragadin and di Gara, Venice, 1599



Gimmel: The junction of the vertical and lower horizontal stroke at the base is very pronounced and follows closely the model of the gimmel in Hb25 (S) and Hb26 (S).

Lamed: The termination to the ascender is similar to Hb6 (S) and is angled at 45 degrees with a serif-like stroke.

Aleph/Lamed Ligature: The termination to the ascender is similar to lamed, but more delicate.

Extended characters: The specimen (4528 f. 7 for example), only shows the extended heh, but there are more available in printed examples. These may have been added at a later stage, but a still bear the mark of Le Bé's hand

Punctuation. The double lozenge 'sof pasuq' (end of verse) appears in the specimen (4528, f. 7 for example), but the raised dot appears in later editions.

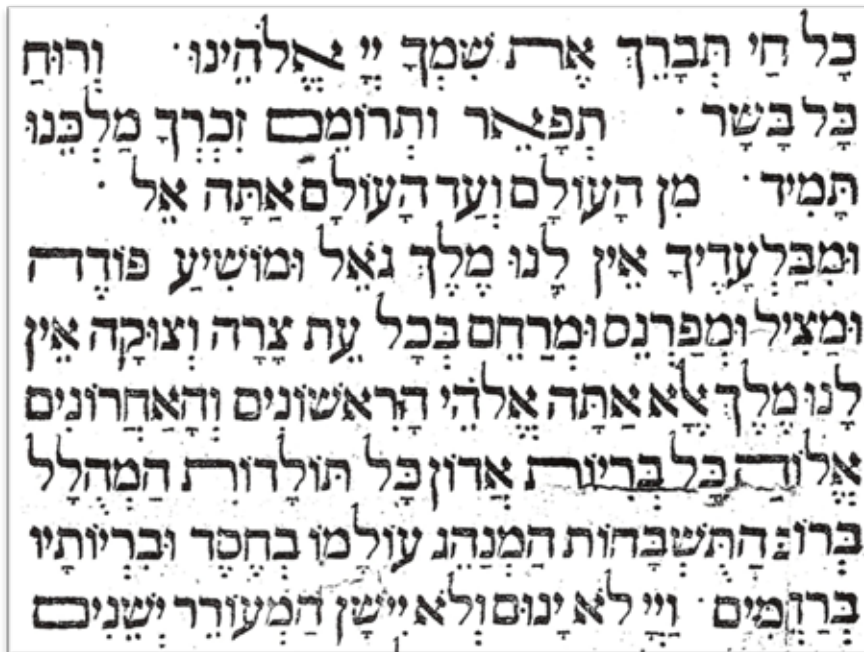

Fig. 2.64: Hb 10 (S) Specimen from Bragadin and Di Gara's Machzor, Venice, 1599 (BL ORB 30/171))

This typeface appears to have been used very widely, throughout the sixteenth century in Venice and elsewhere in Italy. It was a useful size for both headings and large display type settings, such as used in prayer books. It also had a pointed version. It was used in Basle by the printer/publisher Konrad Waldkirch, who obtained them from Ambrosius Froben. Froben had persuaded the Jewish printer Israel Zifroni to come to Basle from Italy, where he had worked for Vincenzo Conti in Cremona. Harry Carter wrote with some certainty that 'the types of Talmud, Square and Rashi, are those cut in Venice in 1545-50 by Guillaume Le Bé for Giustiniani, the finest of the Hebrew faces'³⁴⁶ and it seems quite certain that the conduit for their arrival in Basle was Zifroni. He was apparently able to cast type as well.³⁴⁷

This same typeface was also found in the editions of Aharon Prostitz in Cracow, yet the route of the transmission is not so clear. It has been claimed that Prostitz bought these typefaces via Giorgi di Cavalli and Giovanni Grypho in Venice, when they

³⁴⁶ Harry Carter, 'Review of Die Basler Hebraeischen Drucke (1492-1866)', *The Library*, S5-XX1 (1966), p. 340

³⁴⁷ Rudolf Post and Jutta Schumacher, 'Die Jüdische Drucker Israel Sifroni in Freiburg i. Br.', *Zeitschrift des Geschichtsvereins Schau-ins-Land*, 125 (2006), pp. 65-66. See also Marvin J. Heller, 'Ambrosius Froben, Israel Zifroni and Hebrew Printing in Freiburg im Breisgau', *Gutenberg-Jahrbuch*, 80 (2005)

closed their press in 1568, but there are no documents to date to support this claim.³⁴⁸

This typeface also appears to have found its way to the Frankfurt region in Germany. It was used for occasional Hebrew words in a work of the English Hebraist Hugh Broughton in which the main English commentary is most probably Garamont's Great Primer Italic, with curious composition characteristics, such as the alternate use of a special sort of the letter 'w' or the use of two 'u's to compose the letter 'w'.³⁴⁹ So as to fit the Hebrew into the commentary text, the ascenders and descenders on some of the characters were trimmed off, for example on the Lamed and the ayin. Daniel Averi or Aubry was the son of Johann (or Jean) Aubry, who together with Claude de Marne were partners with André Wechel in his re-established Frankfurt press. Both appear to have been French Calvinists and found the more Lutheran atmosphere in Frankfurt oppressive, and moved to the more welcoming atmosphere of the new town of Hanau (Neustadt Hanau), near Frankfurt am Main.³⁵⁰

There was also a *Typographia Orientalis* active there from 1609 to 1630, and later from 1707 to 1714. The Christian printer Hans Jakub Henne was active in this press until his death in 1613. The inventory of the stock of this press from September 1611 does not list any Hebrews by name, but does mention 'Allerley Schriften' (additional types) and 'Quadrata', which could mean square Hebrews or spacing. Yet the inventory does list several 'Garamond antiqua and cursiff' (Roman and Italic), which is most probably an indication of size and not origin, as well as five 'Graecum' types (Greek), including one 'Garamond graecum'.³⁵¹ As several Le Bé Hebrews were found in the editions examined from the Hanau press, the trail of acquisition must surely point back to either sales at the Frankfurt Book Fair or possibly to types brought from France by the French Protestant emigrés.³⁵²

The *Specimen Characterum* of Johann Berner in Frankfurt am Main of 1622 shows this Le Bé Hebrew without an attribution.

³⁴⁸ Bernhard Friedberg, *Toldot ha-defus ha-Ivri be-Polanyah: me-reshit hivasdo bi-shenat 294 ve-hitpathauto ve ad zemanenu* (History of Hebrew Typography in Poland) (Tel-Aviv, 1950), p. 5, Heller, 'Ambrosius Froben, Israel Zifroni and Hebrew Printing in Freiburg im Breisgau',

³⁴⁹ I am grateful to Hendrik Vervliet for his assistance in identifying this typeface. See Vervliet, *French Renaissance Printing Types: A Conspectus*, p. 318

³⁵⁰ See Jutta Martini, 'Hanauer Drucker und Verleger von 1593 bis 1776', *Gutenberg-Jahrbuch*, 73 (1998), pp. 194-196 and Gustav Könnecke, *Hessisches Buchdruckerbuch enthaltend Nachweis aller bisher bekannt gewordenen Buchdruckereien* (Marburg in Hessen: N.G. Elwert, 1894), pp. 124-135. See also Rachel Heuberger and Stadt- und Universitätsbibliothek Frankfurt am Main, *Hebräische Drucker und Drucker im Frankfurter Raum* (Frankfurt a. M.: Stadt- und Universitätsbibliothek Frankfurt am Main, 1994)

³⁵¹ Friedrich Bauer, *Handbuch fuer Schriftsetzer ... Dritte neu bearbeitete Auflage, etc* (Frankfurt am Main: Verlag von Klimsch & Co., 1910), p. 34

³⁵² Könnecke, *Hessisches Buchdruckerbuch*, pp. 139-141



Fig. 2.65: Hb10 (S) Portion of specimen from Johann Berner's *Specimen Characterum*, Frankfurt am Main, 1622 (From *Type Specimen Facsimiles 1*, 1963)

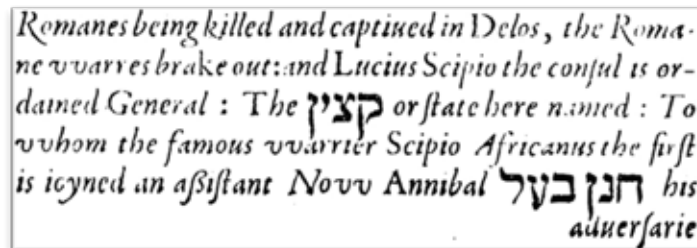

Fig. 2.66: Hb10 (S) Specimen from Hugh Broughton, *Daniel with a Brief Explanation*, Daniel Averi, Hanau, 1607, Actual size (BL 1003.b.9.(1.)

Attributions for this typeface in printed editions:

- *Mishneh Torah*, Venice, Giustiniani, 1550
- Benjamin of Tudela, *Masa'ot shel Rabbi Benyamin*, Ferrara, Usque, 1555?
- *Maharil*, Cremona, Conti, 1558?
- *Sefer Arba'ah Turim*, Cremona, Conti, 1558
- *Arba'ah Turim* Cremona, Conti, 1558
- Joseph Caro, *Sefer Toldot Yitzhak*, Riva di Trento, Cardinal Christoforo Madrucci and Jacob Marcaria, 1558
- *Sefer Shevile Emunah*, Riva di Trento, Jacob Marcaria, 1559
- *Sefer Hovat HaLevanot*, Mantua, 1559
- *Hazeruni*, Cremona, Conti, 1559
- *Shirei Musar HaSekhel*, Rufinelli, Mantua, 1560
- *Goren Nakhon*, Riva di Trento, 1562
- *Sefer Tanhuma*, Mantua Rufinelli, 1563
- *Arba'ah Turim*, Venice, Giovanni Grypho, 1564
- *Sefer Ruach Hen*, Cremona, Conti, 1566
- Ben Joseph, Isaac, *Amudei Golah (Semak)*, Cremona, Vincenzo Conti, 1556
- *Rabenu Bahye*, Venice, di Cavalli, 1566
- David ben Joseph Abudarham, *Leperush Tefilot HaShana*, Venice, Di Cavalli, 1566
- *Shulchan Arukh*, Venice, Giovanni Grypho, 1567
- *Sefer Meir Iyov*, Venice, di Cavalli, 1567

- *Shulhan Arukh*, Venice, di Cavalli, 1567
- *Sefer Kol-Bo*, Venice, di Cavalli, 1567?
- *Shulhan Arukh*, Venice, di Cavalli, 1567
- *Machzor*, Venice, di Cavalli, 1568
- *Sefer Haguda*, Cracow, Prostitz, 1571?
- *Mishneh Torah*, Venice, Bragadin, 1574
- *Sefer Kavanot HaAggadot*, Basle, Ambrosius Frobenius/Zifroni, 1580
- Générard and Halaphta, *Hoc est chronologia Hebraeorum maior*, Basle, Ambrosius Froben, 1580
- Yosé ben Halaphta, *Seder 'Olam rabba: Seder 'Olam zuta*, Basle, Ambrosius Frobenius, 1580
- Eliezer Ashkenazi, *Ma'asei Hashem*, Venice, Di Gara, 1583
- Koppelman, *Sefer Misle Su'alim*, Freiburg im Breisgau, Zifroni, 1583
- Gerondi, *Sefer Chaje Olam*, Freiburg im Breisgau, 1583
- Benjamin Tudela, *Masa'ot shel Rabi Benjamin*, Freiburg im Breisgau, Zifroni, 1583?
- Koppelman, *Ohel Ja'akov*, Freiburg im Breisgau, Zifroni, 1583/84
- *Sefer Toledot Aharon*, Freiburg im Breisgau, Zifroni, 1584
- Koppelman, *Targum shel Chamesh Megilot*, Freiburg im Breisgau, Zifroni, 1584
- *Tsemach David*, Venice, Ioannis de Gara, 1586
- *Sefer Sha'arei Dimah*, Venice, Di Gara and Bragadin, 1586
- *Sefer She'eolot uTeshuvot*, Venice, Di Gara, 1586/7
- *Sefer Derash Mosheh*, Cracow, Prostitz, 1589?
- *Sefer Tana Devrei Eliahu*, Venice, Zanetti, 1598
- *Siddur*, Basle, Waldkirch, c. 1598
- Robert Bellarmine, *Institutiones linguae Hebraicae*, Antwerp, Vidua & Moretus, 1596?
- *Machzor*, Venice, Bragadin and di Gara, 1599
- *Sefer Toledot Aharon*, Venice, Bragadin, 1591
- *Shnem Asar Derashot*, Venice, Di Gara, 1596
- *Pentateuch*, Venice, Bragadin and di Gara, 1597
- *Sefer Divrei Shelomo*, Venice, Zanetti, 1598

- *Pithu Sha'arim/Shā'arei Dura*, Basle, Waldkirch, 1599
- *Sefer Harukh*, Basle, Waldkirch, 1599
- *Sefer Tiferet Israel*, Venice, Zanetti, 1599
- *Sefer Lashon HaZahav*, Venice, Zanetti, 1599
- Hugh Broughton, *Epistolae variae et variarum linguarum, de Byzantiacis hebraeis ...*, Basle, Waldkirch, 1599
- *Sefer Urim ve Tumin*, Zanetti, Venice, 1603?
- Hugh Broughton, *Daniel with a Brief Explanation*, Hanau Daniel Averi, 1607?
- Léon, Moshe de, *Zot HaSefer HaNefesh HaHochma*, Basle, Waldkirch, 1608
- *Hagadah shel Pesach*, Venice, Israel ben Daniel Zifroni, 1606
- *She'elot u-Teshovot*, Hanau, Hans Jakob Henne, 1610?
- *Arba'ah Turim*, Hanau, Hans Jakob Henne, 1610?
- *Hamishah Humshe Torah*, Hanau, Hans Jakob Henne, 1610?
- Mayr, *Institutiones Linguae Hebraicae*, Augsburg, 1616?
- Johann Berner, *Specimen Characterum seu Typorum Probatissorum*, Frankfurt am Main, 1622
- *Mnemonema Historicum Montrans*, Vindshemiae (Bad Windsheim), Typis Christophori Redelhameri, 1685?
- *Talmud*, Berlin and Frankfurt an der Oder, 1715-1739?

Chapter 3: Le Bé's types from his Paris period

An important object of this thesis has been to situate Le Bé in the historical context of his time, to find out as much as possible about the man himself, his family, his business connections, his financial and social standing, and how he might have stood in relation to the major religious issue of his day: Catholicism versus the reformed Protestant (Calvinist) Church. Guillaume I Le Bé lived the entirety of his life in the sixteenth century, and most of his adult life was active as a punchcutter and paper merchant in Paris during the period known as the French Wars of Religion, which began in 1562 and only terminated in 1598, the year of his death. He would no doubt have experienced at first hand the events leading up and culminating in the horrific St Bartholomew's Day Massacre in August 1572. He mentions these wars once in his annotations in a passing reference to the 'Troubles'.³⁵³

The effect of the 'troubles' on the booksellers and publishers in Paris has been summarised as 'une époque qui avait vu la ruine à peu près totale de l'édition Parisienne'. As a supplier of both paper and type to many of the major printers in the Quartier de l'Université in Paris, Le Bé would no doubt have seen the effect of this 'ruine' in his business and this is reflected in the annotations and the number of his typefaces created during the most trying periods of the Wars of Religion. It would fall to his son, Guillaume II, to exploit the material accumulated by his father and make the Le Bé foundry into 'l'une des plus grandes fonderies d'Europe'.³⁵⁴

There are in fact quite a few extant documents attesting to Le Bé's life, his business dealings and connections, his social standing and family matters.³⁵⁵ Most of these documents date from around the period Le Bé returned to Paris from his stay in Venice, and attest to his growing social position and wealth. Already in 1548, while he was still in Venice, his father had acquired a house in the Paris suburb of Gentilly from the paper merchant Claude Duboys, as result of some unspecified financial dealings at the annual Champagne fair in Brie in 1543.³⁵⁶ Further acquisitions of property in Gentilly were made in 1551 and 1569. This was quite a common practice, where property or land (*terres agricoles*) was purchased with the view of renting it out for income.³⁵⁷

Not long after his return to Paris, in March 1551, Guillaume I Le Bé married Loyse Lambert. She was, according to the notarial document, the daughter of Nicole Lambert, a *barbier chirugien juré*, thus probably someone of similar social status to

³⁵³ N.A.F. 4528, f. 9

³⁵⁴ Henri-Jean Martin, *Livre, pouvoirs et société à Paris au XVIIe siècle, 1598-1701* (Genève: Librairie Droz, 1969), pp. 32, 363

³⁵⁵ See Appendix E, p.498 for a full listing of known documents.

³⁵⁶ Renouard, *Documents sur les imprimeurs, libraires, cartiers, graveurs, fondeurs de lettres*, p. 154. Gentilly is located just to the south of the present day Cité Universitaire in the 13th and 14th arrondissements, which would have been a short journey from Le Bé's residences in Paris.

³⁵⁷ Florine Stankiewicz, 'Répertoire de l'imprimeur Michel Le Noir - L'EAD au service du livre ancien', Université de Lyon, 2009), p. 36

the Le Bé family in Troyes, who were ‘papetiers jurés’.³⁵⁸ The dowry (*la dot*) paid by the bride’s family was 1000 livres tournois, and part of this sum was destined to provide clothes and jewellery for the wedding dress in ‘an honest way’ according to her station.³⁵⁹ Le Bé or his family put down a dowry (*douaire*) of 400 livres tournois, whose purpose was to support the wife in the case of the death of the husband.³⁶⁰ It is worth noting several other details of this marriage contract. The ceremony was clearly a Catholic and not a Protestant rite (‘... sera de brief fait et solemnisé en face de Ste eglise’); the bridegroom is named as ‘Guillaume Le Bé le jeune’ (the younger) and his father as ‘Guillaume lebé l’aisne (the elder), marchand papetier demeurant a Troyes en Champagne’, and the address for Guillaume Le Bé le jeune is given as ‘rue St Jehan de Beauvais a Paris’. This mention clearly links Guillaume I Le Bé to his father, who, as previously noted, was probably the fourth in the Le Bé family to bear this Christian name.

The witnesses to this marriage were Jacques Kerver, Oudin Petit, Thiellemann Kerver, and Jehan de Roigny, all *marchans libraires*, in addition to several other witnesses who were apparently friends of the bride’s father. The Kervers are well documented in the history of Parisian booksellers, and Oudin Petit is known to have been an active Protestant who was murdered in the Saint-Barthélemy massacre of 1572.³⁶¹ This point is important for assessing Le Bé’s religious allegiances and his more tolerant attitude to members of the reformed church.³⁶² As a comparison, the Parisian printer and bookseller Nicolas Chesneau was firmly committed to the Catholic cause, and not only in the editions he published. In November 1562 he took an active part in the defence of the city gates and recorded that he ‘was forced on the spot to wield weapons instead of books, and with the citizens of this town, I did my duty in defending the gates, while a skirmish with the enemies of the Church of God was taking place outside the city walls, at Notre-Dame-des-Champs’. He also referred to the Protestant troops who pursued him at one point as ‘those who preach nothing in France but an armed gospel, a gun-blazing Christ, all blackened with smoke’.³⁶³

Whatever were the true religious allegiances of Guillaume I Le Bé, these attitudes had hardened by the time of his son Guillaume II Le Bé. Guillaume II apparently

³⁵⁸ Archives Nationales, Minutier Central, ET/LXXIII/17

³⁵⁹ sur laquelle somme ledit futur espoux sera tenu habiller et enjoyaullier dhabillemens nuptiaux ladite Loyse Lambert honnestement selon son estat.

³⁶⁰ Jacques Lelièvre, *La pratique des contrats de mariage chez les notaires au Châtelet de Paris de 1769 à 1804* (Paris: Cujas, 1959) Le douaire, soit coutumier soit préfix, est un terme de droit ancien désignant la portion de biens que le mari réserve à son épouse dans le cas où celle-ci lui survivrait. La bénéficiaire est dite douairière. Le douaire est un élément fondamental du droit des gens mariés sous l’Ancien Régime.

³⁶¹ Denis Pallier, ‘Les victimes de la Saint-Barthelemy dans le monde du livre parisiens, documents’, in *Le livre et l’historien: Etudes offertes en l’honneur du Professeur Henri-Jean Martin*, ed. by Henri Jean Martin and Frederic Barbier (Geneve: Librairie Droz, 1997), p. 144

³⁶² I am grateful to Geneviève Guilleminot of the Bibliothèque Nationale de France for clarifications on this particular document.

³⁶³ Luc Racaut, ‘Nicolas Chesneau, Catholic Printer in Paris during the French Wars of Religion’, *The Historical Journal*, 52 (2009), pp. 28-29. The original French is ‘ceux qui preschent plus en France qu’une evangile armée, qu’un Christ empistollé, tout noiricy de fumée ..’

refused to publish works by 'heretics' such as the Protestant scholar Isaac Casaubon, as was noted by Casaubon in a letter to Thomas Erpenius in 1611.³⁶⁴

Annie Parent has examined in some detail the marriages of *marchand libraires* in Paris during the sixteenth century. The sums involved in the Le Bé marriage contract are not the highest recorded – over 10,000 livres tournois in one case, but it is certainly well above the mean and thus situates Le Bé in a higher level of the Parisian bourgeoisie of the period. Annie Parent comments that this shows 'l'extrême concentration des familles, une dizaine tout au plus, qui se partagent les grandes fortunes dans le monde du livre parisien'.³⁶⁵

The next important document relating to Le Bé's social and professional status is dated some fifteen days after the marriage contract, that is to say the 15th March 1552 and records the purchase of 'deux maisons contiguës, rue Saint-Jean-de-Beauvais l'une faisant le coin de la rue Saint-Jean-de-Latran' for the price of 3,050 livres tournois'.³⁶⁶ It is possible that this document is a formalisation of an earlier agreed sale, for Le Bé's address on the earlier marriage contract is given as 'rue St Jehan de Beauvais'. In 1561 Le Bé purchased 'la moictié divisée dune maison, droictz, aisances et appartenances dicelle, comme elle se poursuit et comporte, assise a Paris Rue de Beauvais, faisant le coing de ladite rue et de la rue St Jehan de Latran... dont lautre moictié apartenoit audit deffunct Guillaume Lebé par la succession de feu son père'.³⁶⁷

A further document cited in the 1598 *Inventaire après décès*, and dated to January 1572, relates that Le Bé purchased 'une maison, petite cour et appartenances, en laquelle pend pour enseigne "la Grosse Escriptoire" assise a Paris en la rue St Jehan de Latran et ladite vente avoit esté faicte aux charges et moienant le pris et some de dix huit cens livres tz'.³⁶⁸ This property was sold by 'Guillaume le Cirier son frere escuier³⁶⁹ gentilhomme servant ordinaire de Monseigneur le duc d'Allancon' who is mentioned in the 1552 contract, and it is possible that there were parts of the property that still were not owned by Le Bé. Yet, certainly by 1572, Le Bé appears to have owned the entirety of this property. The rue Saint-Jean-de Beauvais was known earlier as the Clos Bruneau, and is labelled as such on some earlier maps.³⁷⁰

The Parisian printing and bookselling community in the sixteenth century was concentrated in a compact area, grouped around the rue St. Jacques, in what is now the fifth Arrondissement of Paris. The reason for this concentration was the proximity

³⁶⁴ Isaac Casaubon and Theodoor Jansson van Almeloveen, *Isaaci Casauboni Epistolæ* (Roterodami: Typis Casparis Fritsch et Michaelis Böhm, 1709), pp. 375-376 as cited in Grafton and Weinberg, "I have always loved the holy tongue" p. 301

³⁶⁵ Parent, *Les métiers du livre à Paris au XVIe siècle (1535-1560)*, pp. 193-194

³⁶⁶ Renouard, *Documents sur les imprimeurs, libraires, cartiers, graveurs, fondeurs de lettres*, p. 154 (Archives Nationales S.1652, f^o. 22 verso, 3ième série)

³⁶⁷ Guillaume Le Bé, *Inventaire apres deces*, 14 juillet 1598, f^o. 21

³⁶⁸ Guillaume Le Bé, *Inventaire apres deces*, 14 juillet 1598, f^o. 23

³⁶⁹ le plus bas et premier degre de noblesse (Jean Nicot: *Le Thresor de la langue francoyse* - 1606)

³⁷⁰ Adolphe Berty, *Topographie historique du Vieux Paris. Région centrale de l'Université ... Extrait du Grand Plan d'Adolphe Berty* (Paris: Imprimerie Nationale, 1897), pp. 91-102

to the University of Paris, which put booksellers, printers and publishers 'en contact perpétuel avec la population des écoliers, d'étudiants de tous pays, de professeurs et de savants que les si nombreux collèges attiraient et retenaient dans le quartier de l'Université, centre intellectuel de Paris'. The other obvious reason for what Renouard describes as being 'agglomérées les unes auprès les autres', was the need to have all the relevant book production trades at close hand to each other, such as book sellers, printers, type founders, book binders and paper merchants.³⁷¹ And indeed it can be said that Le Bé lived in a very small and interconnected world, from his apprenticeship with Robert Estienne in the rue des Carmes until his death in 1598. Renouard's detailed listing of the printers and booksellers, street by street, shows, for example, that there were over 130 printers in the rue Saint-Jacques alone, and over 30 in the rue Saint-Jean-de-Latran.³⁷² Thus one can assume close relationships, both professional and personal amongst this community.

The following historical maps present a more visual representation of this part of sixteenth-century Paris. The first is a detail from what is known as the Plan de Bâle, and was produced in about 1550 by Germain Hoyau and Olivier Truschet. It shows dwellings, although it is difficult to say how accurately they are drawn, as for example the site where the Maison de la Grosse Escriptoire should be located looks to be unbuilt on this map.³⁷³ The second plan is from the Lenoir *Plan archéologique de Paris: feuille XIV (université)* of 1888 which shows the University area, and the Maison de la Grosse Escriptoire which is clearly marked. Renouard cautions that 'presque toutes les notes qui leur (les libraires et les imprimeurs) sont consacrées sont en désaccord complet avec ce que nous avons énoncés sur leur compte'.³⁷⁴ The final map is from Renouard and shows the area of the University, the colleges, churches and city walls of the sixteenth century, and its relation to the Île de la Cité.³⁷⁵

³⁷¹ Philippe Renouard, *Imprimeurs parisiens, libraires, fondateurs de caractères et correcteurs d'imprimerie: depuis l'introduction de l'imprimerie à Paris (1470) jusqu'à la fin du XVIe siècle* (Paris: A. Claudin, 1898), p. x

³⁷² Renouard, *Documents sur les imprimeurs, libraires, cartiers, graveurs, fondateurs de lettres*, pp. 408-417

³⁷³ Jean Boutier et al., *Les plans de Paris des origines, 1493, à la fin du XVIIIe siècle: étude, cartographie et catalogue collectif* (Paris: Bibliothèque nationale de France, 2002). For an interactive version see also 'Plan de Bâle Truschet et Hoyau 1552' (<<http://www.bloy.geometre-expert.fr/VUESHISTO/TEXTESPLANS/1552.htm>> [Accessed 6 Novembre 2013]

³⁷⁴ Renouard, *Imprimeurs parisiens, libraires, fondateurs de caractères et correcteurs d'imprimerie*, pp. xiv-xv

³⁷⁵ *Ibid.*, pp. 384-385

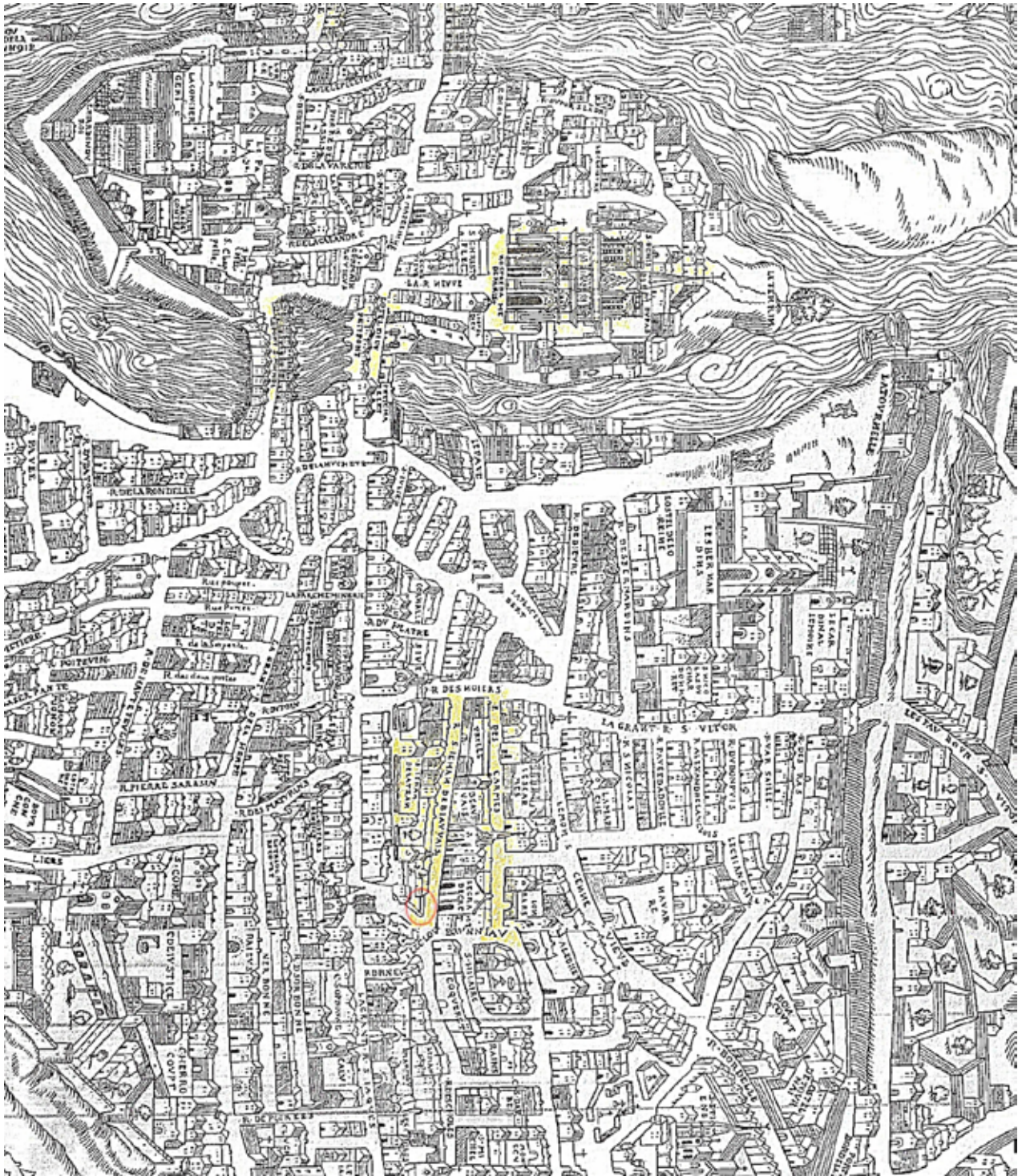

Fig. 3.1: Plan de Bâle, c. 1550 by Germain Hoyau and Olivier Truschet. La Grosse Escritoire marked in red circle and book trade areas marked in yellow

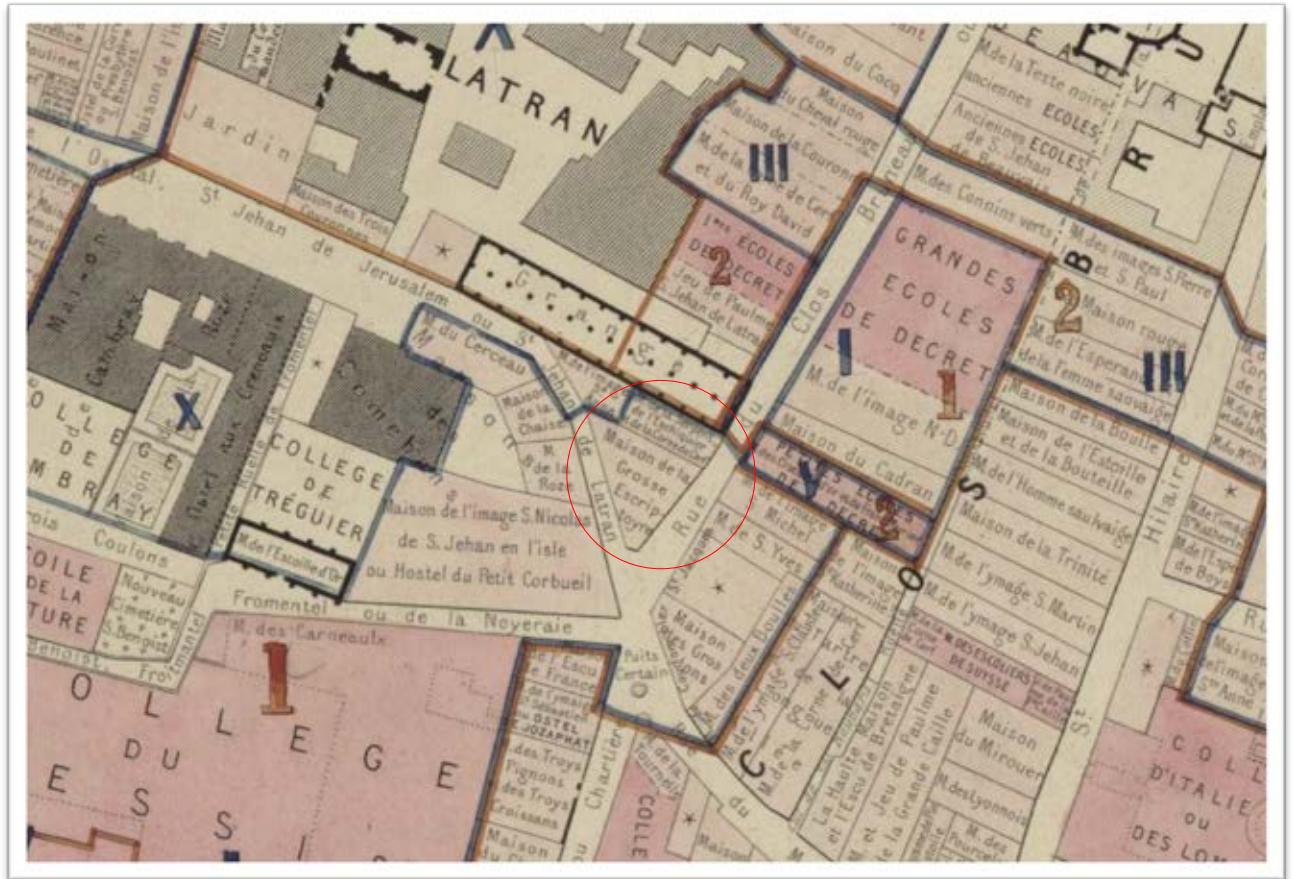

Fig. 3.2: Albert Lenoir, Plan archéologique de Paris: feuille XIV (Cartes et Plans - GE D- 6958 Bibliothèque nationale de France) Maison de la Grosse Escrip marked in red circle.

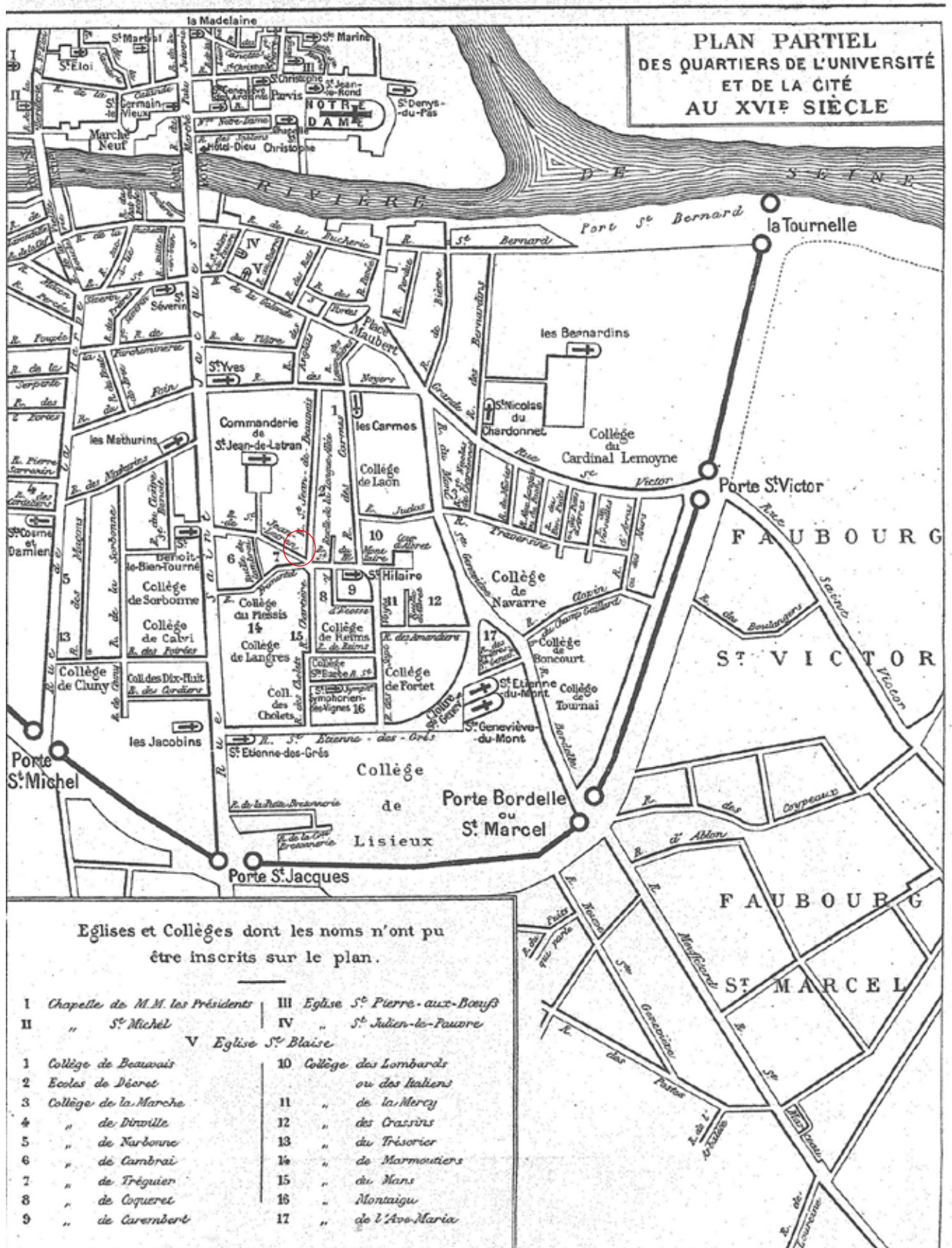

Fig. 3.3: Renouard, Plan Partiel des Quartiers de l'Université, 1898. Location of the Maison de la Grosse Escripote marked in red circle

Returning to our survey of documents relevant to Le Bé's life, perhaps the most illuminating of all is the *Inventaire après décès*,³⁷⁶ dated the 14th July 1598, which is worth a closer examination and analysis. It provides an enormous amount of information as to Le Bé's household and life style.³⁷⁷

An *Inventaire après décès* was in essence a detailed listing of all the contents of the deceased's house or business premises, compiled with the purpose of the division of the inheritance amongst the inheritors, starting from the lower to upper parts of the house. These inventories tended to follow a fairly standard form, with a preamble listing the parties who had requested the inventory and the name, address and occupation of the deceased, and finally the names of the notaries, assessors and specialist assessors if they were required.³⁷⁸ A complete listing of the contents, room by room, then followed, each item or group given an assessment either in écus or in livres, sols and deniers which was the theoretical 'monnaie de compte'. The rate was fixed at three livres to the écu in the 1560s.³⁷⁹

The inventory would then describe in an abbreviated form, any documents which were found in the possession of the deceased and could have an impact on any monies owed to the inheritors. In certain cases, as for example in the inventory of the Le Bé foundry in 1685, the inventory was preserved with the main inventory. Sadly none of the listed documents were preserved in this inventory of 1598, apparently on the express wishes of the inheritors.

A word is appropriate here on the function of the will or testament. They appear to have been much less common than *inventaires après décès*. According to Pierre Chaunu, wills represent only 1.5 to 2 per cent of the total number of notarized acts.³⁸⁰ There does not appear to have been a will for Guillaume I Le Bé, which is a pity, as it might have given more details on his religious affiliations. The will of his mentor Claude Garamont dated the 23rd September 1561, which has survived, gives clear indications in its details that he had Protestant sympathies and gives no details of the contents of his foundry.³⁸¹ He did appoint the bookseller and printer André Wechel as one of his executors, a person who is who mentioned directly by Le Bé and who

³⁷⁶ This would be called an inventory of goods or probate inventories in the English sense. See J. Linda Drury, 'Inventories in the Probate Records of the Diocese of Durham', *Archaeologia Aeliana*, 5th series, 28 (2000) (2000) for an analysis of probate inventories in Durham for the period (c.1550- c. 1720

³⁷⁷ The *inventaire après décès* allows us to date Le Bé's death to sometime in the middle of June 1598: 'Lequel seroit decedé depuis ung mois en ca, ayant survescu ladite defuncte Loise Lambert par longue espace de temps, sans avoir fait aucun inventere'.

³⁷⁸ Madeleine Jurgens, *Documents du Minutier central des notaires de Paris. Inventaires après décès* (Paris: Archives nationales, 1982)

³⁷⁹ I am grateful to Rémi Jimenes, doctorant en histoire du livre au Centre d'études supérieures de la Renaissance Tours for his clarification of this issue.

³⁸⁰ Pierre Chaunu, 'Mourir à Paris (XVIe-XVIIe-XVIIIe siècles)', *Annales. Économies, Sociétés, Civilisations*, 31e année (1976)

³⁸¹ Guilleminot-Chrétien, 'Le Testament de Claude Garamont', in *Le livre et l'historien: Etudes offertes en l'honneur du Professeur Henri-Jean Martin*, ed. by Martin and Barbier (Geneve: Librairie Droz, 1997), p. 135

was forced to flee Paris for Frankfurt in 1572 due to his Protestant beliefs. The inventory of the Garamont foundry was drawn up after Garamont's death on the 18 November 1561 by Le Bé and Jean le Sueur, another *fondeur de caractères*. This inventory does not appear to have survived, but it came into the possession of the type founder Jean-Pierre Fournier, l'aîné, in the eighteenth century as he mentions it in his letter to the *Mercure de France*, in May 1756.³⁸²

Guillaume I Le Bé's *Inventaire après décès* is a document of 30 pages which follows the standard form, with a preamble, a detailed listing and assessment of items found and a list of documents relating to Le Bé, mainly monies owed to him.³⁸³ It was compiled by the Parisian notaries Jehan (Jean) Luson and Nicolas Le Noir, at the request of Le Bé's children: his son Guillaume (II), his daughter Madeleine, her husband Claude Andrenas, and his daughter Marie Le Bé.³⁸⁴ The preamble to the inventory informs us that, at the time of death, Guillaume Le Bé was widowed and that his wife Loyse Lambert, whom he had married in March 1571, had died sometime before 1583, the last mention of her in a known document. It also tells us also that his daughter Madeleine had married Claude Andrenas, who was a 'marchant mercier, grossier, jouaillier a Paris', from what appears to be a strongly Catholic family if one is to judge from the donation of a relic of St. Benoît to the Abbey of Saint-Germain in Paris in 1657.³⁸⁵ Once again, this is a sign of Le Bé's at least outward show of Catholic orthodoxy.

The *Inventaire après décès* gives a picture of what must have been a very typical bourgeois household for the Paris of that period.³⁸⁶ It describes what was probably a two-story dwelling (referred to as a *hostel*)³⁸⁷ with a cellar (*une cave*), kitchen (*une cuisine*), a small antechamber or dining room (*une sallette*), a bedroom in which Le Bé had died, another bed chamber, a small wardrobe (*une garderobbe*), an additional bedroom, and a loft room (*un grenier*). The location of the foundry is not mentioned in this list, but would most probably have been on the ground floor with access to the street. The inventory lists a sizeable wardrobe of both male and female clothes (*les habitz*) in a variety of fabrics, some obviously of great worth such as silk, velour and satin. There is also a detailed listing of household linen (*le linge*). At least

³⁸² I am indebted to James Mosley for his unpublished handlist of documents relating to the Le Bé foundry. See also Fournier and André, 'Lettres polémiques sur la typographie'

³⁸³ Archives Nationales Minutier Central ET/LVX/161. I am grateful to FranceGenWeb and PaléoFGW for their assistance in transcribing this very problematic document from the point of view of the notarial hand of the period.

³⁸⁴ See Appendix F, p. 520 for the full text.

³⁸⁵ Jacques Bouillart, *Histoire de l'abbaye royale de Saint Germain des Prez. Contenant la vie des abbez qui l'ont gouvernée depuis sa fondation: les hommes illustrés qu'elle a donnez a l'Eglise et a l'Etat: les privileges accordez par les souverains pontifes ... Le tout justifié par des titres authentiques, & enrichi de plans & de figures* Paris, 1724), p. XCIX

³⁸⁶ The term 'Bourgeois' meant more specifically un home vivant de ses rentes' (someone living off their income). Here we are using the term to describe a social class largely composed of these sorts of individuals and their families. See Martin, *Livre, pouvoirs et société*, p. 46.

³⁸⁷ See Pierre Couperie and Madeleine Jurgens, 'Le logement à Paris au XVIe et XVIIe siècles', *Annales. Économies, Sociétés, Civilisations*, 17e année (1962) for a detailed study of Parisian houses based on a study of a number of inventaires après décès.

five paintings are mentioned, all of them obviously religious in nature ('la Nativité de Notre Seigneur, le Presche St Jehan Baptiste, Notre Seigneur en croix, l'Anonciation Notre Dame'), but one listed as 'une carte de toile ou est depeincte la ville de Troye'.³⁸⁸ These prints may have been similar in theme and style to the wood engraving which Le Bé sold in the 1580s.³⁸⁹ There is also a mention of several bookcases and a quantity of 170 books, not itemised. This was thus a household of a high level of literacy, whatever the actual subject matter of the books. There was also a small quantity of jewellery, including 'un chappellet garny de sa croix et perle', which is obviously a Rosary, a sure sign of a Catholic household.

It should be noted that, in addition to the Le Bé and his wife, his three children and possibly their spouses living in the house, there was also a servant mentioned in the inventory, Guillemette Chauvet ('servante dudit defunct qui a tousjours demeuré en ladite maison'). One must also add apprentices or *élèves* at various times, of whom Jacques I de Sanlecque was possibly one, as well as other associates.³⁹⁰ For example, a notarial contract dated the 8th April 1564 names the Genevan printer Jehan Anastaze as having nominated his residence 'en la maison de Sire Guillaume Le Bé demeurant St Jehan de Beauvays'.³⁹¹ There could thus have been up to eight people living in the La Grosse Escriptoire at any one time. The overall impression is one of 'l'entassement (crowding) de la population. Certains logent dans les greniers, ailleurs, un ménage et cinq enfants dans une seule pièce. Et cet entassement est encore aggravé par des véritables accumulations de mobilier'.³⁹²

The assessors then proceeded to assess the furnishing found in 'une maison sise au village de Jantilly lez Paris', which is most certainly the property already mentioned in one of the earlier documents.

This inventory does not contain, as was sometimes the case,³⁹³ a summing-up of the total estimate, but the total estimate of the household furniture, utensils, clothes, bed

³⁸⁸ See Georges Wildenstein, 'Le Goût pour la Peinture dans la bourgeoisie Parisienne entre 1550 et 1610', *Gazette des Beaux-Arts* (1962) for a more detailed discussion of the type of paintings common to early modern Parisian households. The Le Bé inventory is briefly mentioned.

³⁸⁹ Jean Adhémar, Bibliothèque nationale, and Andre Linzeler, *Inventaire du fonds français. Graveurs du seizième siècle*. Vol. 2 tom. , (Paris, 1938), pp. 355-360

³⁹⁰ Louis Gabriel Michaud, *Biographie universelle ancienne et moderne L.G. Michau, Libraire-Editeur* (Paris: 45 tom. , 1823), pp. 330-331 (Tome XXIII) and Edmond Werdet, *Histoire du Livre en France depuis les temps les plus reculés jusqu'en 1789. Tom. 1-4* (Paris: E. Dentu, 1861), p. 147 (Troisième Partie/Tome II). Werdet maintains that Sanlecque 'apprit à graver et à fondre les caractères d'imprimerie chez Guillaume Le Bé', whereas Vervliet does not mention this in his *Conspectus*.

³⁹¹ Archives Nationales, ET/LXXIII/58 (J. Anastaze, demeurant chez Guillaume Le Bé, rue Saint Jean de Beauvais, ...bourgeois de Genève, à cause de Jeanne Estienne sa femme, vend à Robert (II) Estienne... le 1/5 de l'imprimerie, matrices, caractères, presses, figures, moules... déclarés en l'inventaire dont la délivrance a été obtenue de Vascosan, par arrêt de la cour, ... moyennant le prix auquel elle a été estimée il y a huit jours par Oudin Petit et Charles Périer, Guillaume Le Bé et J. Le Sueur...)

³⁹² Couperie and Jurgens, 'Le logement à Paris au XVIe et XVIIe siècles', p. 494

³⁹³ See for example the summary at the end of the 1768 Fournier Inventory, ET/LXIV/400

linen and jewellery amounts to 541 escus (écus) and 1182 solz (sous), or the equivalent of over 1600 Livres Tournois.³⁹⁴

How does this figure compare to other inventories for similar levels of Parisian society? The Huguenot notary Antoine Léal left an inventory dated 13 January 1573, which assessed the furnishings, linen, jewellery, and cash in hand at 988 Livres Tournois. The commentary on this inventory is that it describes 'un ménage qui répond bien plus à l'établissement bourgeois qu'on entendrait d'un notaire parisien'.³⁹⁵ Yet another comparison can be seen in the Le Noir dynasty of Parisian printers. Three successive generations are known: the first Michel (died c. 1528); the second Philippe (to c. 1550), and the third Guillaume (active to c. 1560). Their wealth allowed them to enter into the ranks of the 'notabilité parisienne'. They made numerous property purchases around the rue Saint-Jacques and outside Paris - a property in Gentilly is also noted. This is a pattern similar to what one sees with the documents in the Guillaume I Le Bé inventory.³⁹⁶ We also see this pattern going back much earlier, indeed to the mid-thirteenth century, about the time that the Université de Paris was beginning to take shape. The will of the bookseller (*venditor liborum Parisius*) Emery d'Orléans made in Lyons in July 1246 makes it clear that he 'made a profitable career as a provider of books, to students and especially to masters, his business growing apace with the university'. He also 'had amassed an impressive amount of property around Paris', for example a farm (*grangia*) which he owned in Ville l'Evêque in the present-day eighth Arrondissement of Paris and another property outside the Porte St. Victor. The total value of his estate is not known, but it is of interest that he was able to amass a reasonable financial capital and property even in this early period of the Parisian book trade.

Emery d'Orléans will have made part of his fortune from the sale of Pecia and the development of the this system is closely linked to the growth of universities and the growing the growing demand for cheap texts for students.³⁹⁷ It was a progression

³⁹⁴ I am grateful to my colleague Rémi Jimenes for his clarification of the currencies in use in France in the sixteenth century. In effect there were two parallel monetary system in uses: l'écu which was usually a gold coin produced in a Royal mint, which had varying values depending on the period and the rate of the metal used. Then there was the pounds (une livre) which was a theoretical 'monnaie de compte', which was commonly used and was divided into 20 sols (solz) and 240 deniers, but was not an actual physical coinage. At this period one escu probably was equal to three livres.

³⁹⁵ Cited in Barbara B. Diefendorf, 'Les divisions religieuses dans les familles parisiennes avant la Saint-Barthélémy', *Histoire, économie et société*, 7 (1988), p. 66

³⁹⁶ Stankiewicz, '*Répertoire de l'imprimeur Michel Le Noir - L'EAD au service du livre ancien*' Les acquisitions immobilières de la famille sont le second aspect à aborder ici. Elles sont à la fois conséquence de ses succès professionnels et condition de son nouveau statut de notabilité parisienne. En effet, en étendant progressivement son assise foncière, en multipliant les initiatives pour en améliorer la gestion, la famille accède peu à peu au statut de notabilité locale.' (p. 34)

³⁹⁷ Richard H. Rouse and Mary A. Rouse, *Manuscripts and their makers: commercial book producers in medieval Paris, 1200-1500* (Turnhout: Harvey Miller, 2000), pp. 36-39. See also Graham Pollard, 'The pecia system in the medieval universities', in *Medieval scribes, manuscripts & libraries: essays presented to N.R. Ker*, ed. by N. R. Ker, M. B. Parkes, and Andrew G. Watson (London: Scolar Press, 1978)

from the more costly production of individual manuscripts and was in effect the forerunner of the development of a commercial book trade. Relative costs are known for the scribal trade in England for the period 1300 to 1483, which was characterised by an acceleration in production methods and increased output of codices.³⁹⁸

The final section of the inventory is perhaps the most interesting part for what it reveals about Le Bé. Some 33 documents are listed and described, some which have already been discussed regarding property bought by Guillaume Le Bé (the father), or by Guillaume I Le Bé. There is also a number of documents, variously entitled *contract or contrat*, *cellule* (a bill or IOU), and *brevet* (a type of receipt) The IOU records sums of money owed to Guillaume Le Bé by other booksellers and printers, namely Jean Richet, Adrian le Roy, Jean Corbon, Charles Perier, Denis Duval, Mamert Patisson, Estienne Prevosteau, Denis Binet, Guillaume Anuray, Pierre Fieffe, Pierre Luillier,³⁹⁹ Leger Delas, Arnoul Cottrier and Philippes Dupin. Most of these descriptions merely record the date and sum of money owed, so we do not know whether Le Bé supplied paper, type or printed books to these individuals. Yet in the case of the *sentence des juges* – a more formal court order – dated the 20th February 1591, it records that Mamert Patisson, merchant bookseller was ordered to pay a total of 27 écus and ten sous to Le Bé for a fount of type.⁴⁰⁰ The printer Mamert Patisson is of particular interest due to his connection with Robert II Estienne, for Patisson married the widow of Robert II Estienne in 1574 and thus came into the possession of Estienne's house and workshop.⁴⁰¹

The most intriguing mentions of all are to be found on page 29: an appraisal of all the books by Jehan (Jean) Carbon, an appraisal of all the paper (*marchandise de pappier*) by Lois Ron and four sheets of paper containing an inventory of the 'matrices, moules, poinçons et autres ustancilles servans a la fonte de lettres dimprimeries' by Jacques Duclos and Jacques de Sanlecque, dated 20 July 1598.⁴⁰² The note at the end of this item indicates that both Guillaume II Le Bé and Claude Andrenas (his brother-in-law) were satisfied to have this documents described and *not* attached to the actual inventory. This is indeed a great pity, for a record of the Le Bé foundry and what it comprised on the death of Guillaume I Le Bé would have been an important historical record in its own right. This inventory does not appear to have been conserved at the Archives nationales in Paris.

³⁹⁸ Joanne Filippone Overy, 'The cost of doing scribal business: Prices of manuscript books in England, 1300-1483', *Book History*, 11 (2008), pp. 12-13

³⁹⁹ Pierre Luillier (L'Huillier) most probably purchased matrices from Le Bé, as his edition of Gilbert Génébrard's *De S. Trinitate* of 1569 makes use of Hb11(S) within the text.

⁴⁰⁰ Item, une sentence des juges et consulz de ceste ville de Paris, en datte du vingtiesme jour de fevrier mil Vc iiiix xi (1591), signée L....., contenant Mamert Patisson marchand libraire a Paris avoir esté condampné paier audit deffunct Lebe la somme de deux cens vingt ung escus six solz contenu en sa ceddulle du xxixeme (29) juin mil Vc iiiix cinq (1585) et vingt sept escus dix solz pour vente de fonte dimprimerie et avoir esté condampné es despens, taxéz a seze solz.

⁴⁰¹ Michaud, *Biographie universelle ancienne et moderne* p. 129 (Tome 133)

⁴⁰² See Appendix E, page 512 for the full text.

No less an authority than Stanley Morison was of the firm opinion that this inventory formed the basis of the inventory inserted into the 1730 Deed of Sale by which Jean Pierre Fournier (the elder or l'ainé) purchased the Le Bé foundry from the Le Bé sisters. Morison wrote: 'this, therefore, seems to be our ultimate source: that is to say, the c. 1598 inventory, which was copied after the death of Le Bé II sometime after 1643, and again after the death of Le Bé III in 1685. Next it was copied when Jean Pierre Fournier became principal of the foundry in 1730. Thus the inventory of 1730 is, in reality, the inventory of ca. 1598.'⁴⁰³

The three inventories mentioned on this page – books, paper and press – are clear proof that Le Bé was active in *all* of these areas of business. In addition there is also evidence that Le Bé acted as a publisher of more popular items. He is known to have issued at least eight series of albums of wood engravings with titles such as 'Les trente-six figures contenant tous les jeux qui se peuvent (*sic*) jamais inventer et représenter par les enfants' (in 1587), 'Les Apôtres' (c. 1585), 'Fleurs dans les Vases, Costumes de Souverains' (c. 1585), 'Costumes exotiques' (c. 1585), and 'La Chasse' (c. 1580). Some of these, held in the Cabinet des Estampes in the Bibliothèque nationale de France, carry the caption at the bottom 'A Paris, Chez Guillaume le Bé, ruë saint Jean de Beauvais, pres le puits certain'. These consist of rather crudely executed wood engravings showing an image and a few lines of verse in French, with a variety of subjects, such as dignitaries ('L'Empereur or Le Roy de France'), or trades ('Serrurier'),⁴⁰⁴ religious figures ('Saint Pierre'), or even domestic scenes ('comme s'appaisent les petits enfans').⁴⁰⁵ These are not in the style of the popular Renaissance *Emblemata Sacra* images, but are most probably in the style of *l'art populaire parisien* and are dated to about 1580. They may even been produced for children.⁴⁰⁶ In the following generation in 1644, however, Guillaume II Le Bé printed Philippe Desprez' *Théâtre des Animaux*, which does follow the tradition of emblematics and spiritual images. This edition was entirely in French and not in Latin, and was described in the title page as 'enrichy de belles Sentences tirées de l'Escriture Sainte, & orné de Figures, pour ceux qui ayment la Peinture'.⁴⁰⁷

This type of publishing continued into subsequent generations. There is, for example, an edition of Jean Cousin's *La vraye science de la pourtraicture descrite et démontrée* printed in 1671, which again gives the address as 'ruë Saint Jehan de

⁴⁰³ Fournier and Morison, *L'Inventaire de la Fonderie Le Bé*, p. 12

⁴⁰⁴ locksmith

⁴⁰⁵ Bnf, Réserve EA-79-4

⁴⁰⁶ Adhémar, Bibliothèque nationale, and Linzeler, *Inventaire du fonds français. Graveurs du seizième siècle*, pp. 355-357. Adhémar comments that 'Papillon appelle Le Bé le plus habile graveur et fondeur de caracteres de son siècle, but adds that 'les quelques pieces signées par lui n'ont rien cependant qui justifie cet enthousiasme ; ce sont des copies assez ordinaires gravées sur bois avec une saveur populaire. Signalons qu'il a acheté des bois gravés par Jean Leclerc II, et les a edités en y mettant sa marque. See also 'Anciens jeux: a Propos d'un livre rare Intitulé', *Le Magasin Pittoresque*, XV (1847) for examples of the wood engravings of children's games.

⁴⁰⁷ Philippe Desprez, *Le théâtre des animaux, auquel sous diverses fables et histoires est représenté la plupart des actions de la vie humaine* (Paris : chez Guillaume Le Bé, 1644) BnF RES- YE- 879

Beauvais, pres le puits certain'.⁴⁰⁸ This would have been Guillaume III Le Bé and what is of interest here are the use of the Garamont italics and romans in the introduction and descriptions, as well as the specimens of initial letters, which show part of the rich typographic holdings of the Le Bé foundry inherited from Guillaume I Le Bé. Yet a further example of this type of production is a folio edition entitled *Figures des Histoires de la Sainte Bible* published in 1643, 1660 and 1666, with the wood engravings by the engraver Jean Le Clerc – most probably Jean II Le Clerc.⁴⁰⁹ The 1666 edition is of interest once again for the use of the two line Granjon double pica italic, the Colines Roman titling on two line English, the Granjon paragon italic, amongst several others.⁴¹⁰

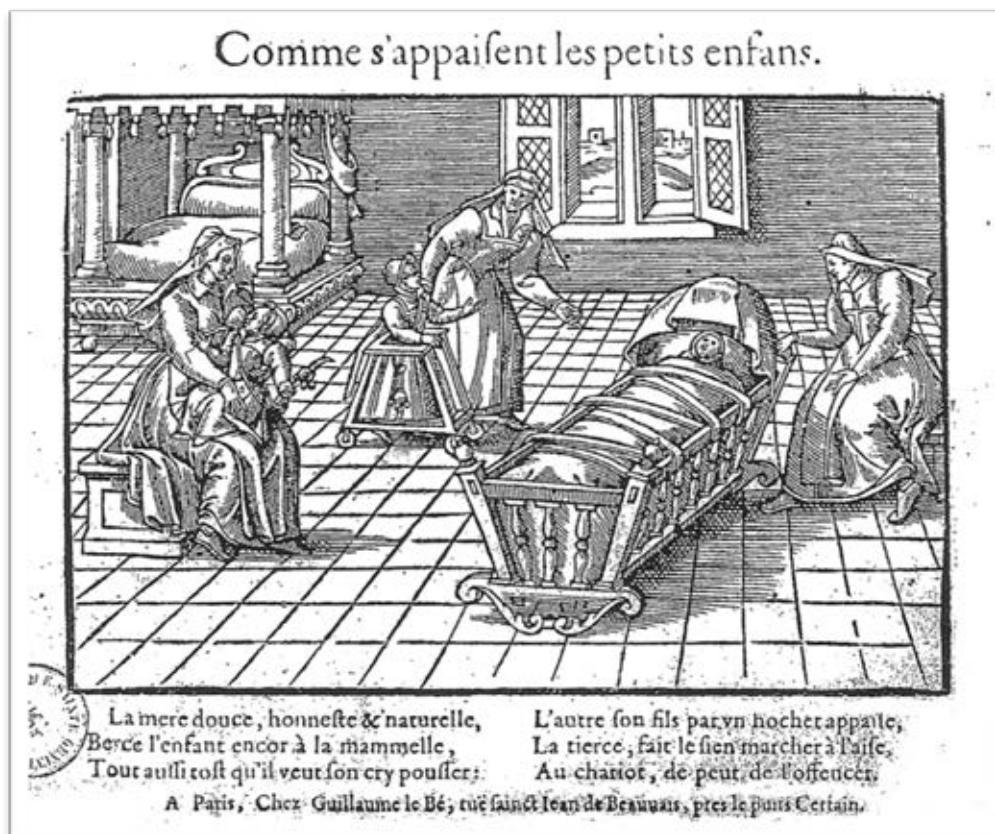

Fig. 3.4: Wood engraving from *Costumes exotiques*, published by Guillaume I Le Bé in 1585 (BnF - Recueil de Gravures sur bois Ea 79 rés., F. 017522) Note the impressum and address for Le Bé at the bottom.

⁴⁰⁸ Jean Cousin, *La vraye science de la pourtraicture descrite et demontrée* (Paris: Guillaume Le Bé, 1671) Wellcome Library Closed stores EPB Suppl. C 60120/C

⁴⁰⁹ For a listing of the various members of the Le Clerc dynasty of engravers see Adhémar, Bibliothèque nationale, and Linzeler, *Inventaire du fonds français. Graveurs du seizième siecle*, pp. 359-367

⁴¹⁰ BL 561*e40. For further discussion on this edition see Howe, 'The Le Bé Family', pp. 18-19

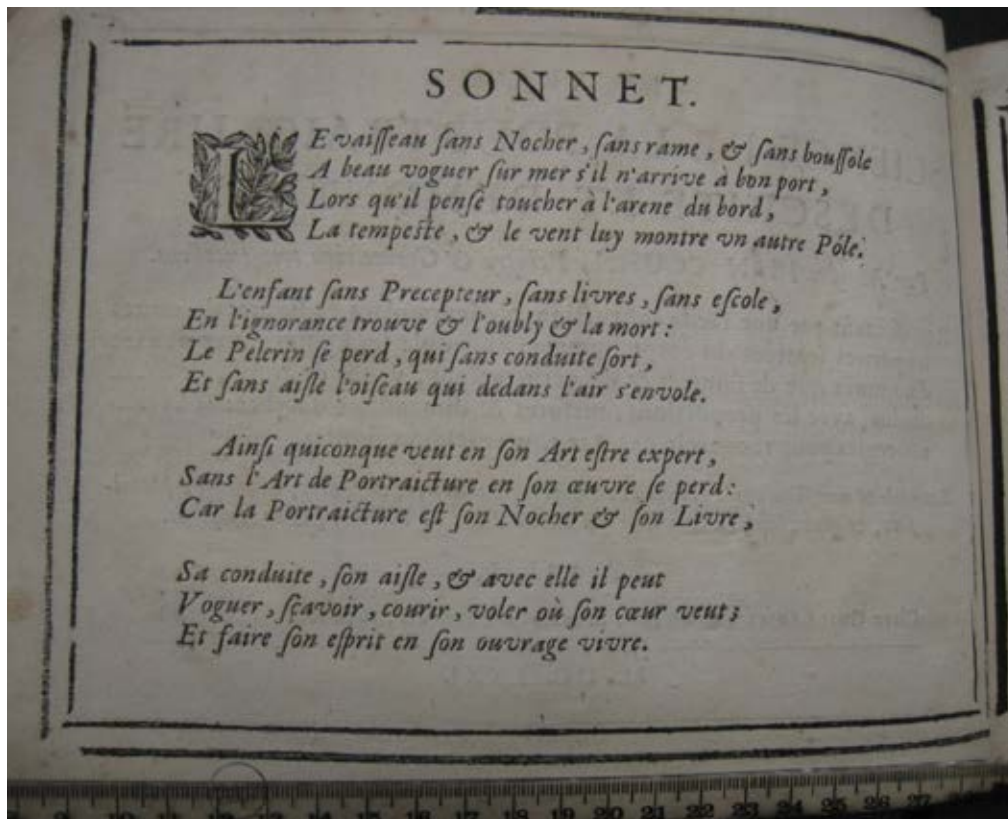

Fig. 3.5: Page from Jean Cousin, *La vraye science de la pourtraicture descrite et demontrée*, Paris: Guillaume Le Bé, 1671. Reduced 70 per cent (From Wellcome Library Closed stores EPB Suppl. C 60120/C)

There is one aspect of Le Bé's activities which has a particular relevance to his typographic output and which requires further clarification and discussion: his types for the printing of music.

Guillaume I Le Bé was also known to his contemporaries as a punchcutter of music types and indeed NAF 4528 shows several specimens of his types. Folio 21v of NAF 4528 shows a printed sheet of what Le Bé calls a *musique grosse* and which was cut in 1555 for Adrien Le Roy and Robert I Ballard, who were named as 'imprimeurs du Roy en musique'. Folios 22v and 23v-24 also show specimens of the same type. Folios 24v, 25, 26 and 26v show examples of a *grosse tablature d'espinette*, dated sometime in the 1550s, and a 'petite tablature d'espinette sur la moyenne musique' dated 1559, also for Adrien Le Roy and Robert I Ballard. The *musique grosse* is a five staff Mensural Roman Notation and the *tablature* is a five staff Virginal Tablature – most probably a double impression.

Le Bé's name is particularly linked with that of Robert I Ballard (active from 1550 to 1588) and his associate, Adrien Le Roy (active 1551- 1589?). Lepreux maintains that Le Roy was an 'excellent musicien, fort habile joueur de luth et de guitar, compositeur de musique et chanteur de la Chapelle du Roi', and that he was responsible for finding works to publish, whereas his brother-in-law dealt with the printing and typography and commercial aspects of the business.⁴¹¹ Adrien Le Roy

⁴¹¹ Georges Lepreux, *Gallia typographica: ou, Répertoire biographique et chronologique de tous les imprimeurs de France depuis les origines de l'imprimerie jusqu'à la révolution*, Série Parisienne

was indeed Robert I Ballard's brother-in-law, having married his sister, but his name disappeared from the Ballard music editions after his death. The Ballard name continued for at least six generations until the mid-eighteenth century, from father to son with a relentless regularity, and the Ballard family had almost a virtual monopoly to print works of music, the first one having been granted by Henri II in 1552. The line of succession – and their periods of activity – ran from Robert I Ballard, to Pierre Ballard (1603 to 1639), to Robert II Ballard (1640 to 1679), to Christophe Ballard (1666 to 1715), to Jean-Baptiste-Christophe Ballard (1694 to 1750), to Christophe-Jean-François Ballard (1741 to 1765), and finally to Pierre-Robert-Christophe (from 1767 to 1788).⁴¹²

An earlier reference had Guillaume I Le Bé related by marriage to Ballard, whose wife was named as Lucrece Le Bé, who took over the management of the Ballard-Le Roy music printing business after the death of Robert I Ballard in 1588. It is more likely that this was a mistaken identification for her real name - Lucrece Le Dugué.⁴¹³ Where and when this error was introduced is not clear, but certainly Edmond Werdet places a Lucrece Le Bé in his list of members of the Le Bé family in his *Histoire du Livre en France* and later Henri-Jean Martin describes Pierre II Ballard as a 'cousin de Le Bé', without citing any supporting documents.⁴¹⁴ Yet it is clear that Guillaume I Le Bé and Robert Ballard were closely linked at least by location. The Ballard Leroy imprints give the address first as 'à l'image Sainte-Geneviève, rue Saint-Jean de Beauvais', which is probably the same house as 'à l'enseigne du Mont Parnasse' in the same street. This was within view of the Le Bé house, the 'Grosse Escriptoire', and one can assume that the two families were in close contact.⁴¹⁵ The Ballard family not only printed and sold music by other music publishers, but had their own foundry, 'de sorte que ce dernier (Pierre II Ballard) pouvait se contenter dans ce domaine des notes nécessaires à l'impression des livres d'Eglise'.⁴¹⁶ The *Inventaire après décès* de Jean-Baptiste Christophe Ballard compiled in 1750 lists some 2,200 editions from the period 1530 to 1746, only some of which were issued by the Ballard

(*Paris et l'Île de France*) (Paris: H. Champion, 1911), p. 347. See also François-Joseph Fétis and Arthur Pougin, *Biographie universelle des Musiciens, et Bibliographie générale de la Musique* (Paris: Librairie de Firmin Didot Frères, Fils et Co., 1860), pp. 279-280 (Vol V) from where Lepreux seems to have taken most of his information.

⁴¹² J-B Wekerlin, 'Histoire de l'impression de la musique en France', *Le Ménestrel*, 34 (1868), pp. 281-282 (282 Aout 1868)

⁴¹³ See Renouard, *Répertoire des imprimeurs parisiens, libraires, fondateurs de caractères et correcteurs d'imprimerie*, p. 15, which was corrected in the later Renouard Imprints. Philippe Renouard, *Imprimeurs & libraires parisiens du XVI^e siècle: ouvrage publié d'après les manuscrits de Philippe Renouard* (Paris: Bibliothèque nationale, 1969), pp. 372-375

⁴¹⁴ Werdet, *Histoire du Livre en France depuis les temps les plus reculés jusqu'en 1789. Tom. 1-4*, p. 65 (Tome IV). See also Martin, *Livre, pouvoirs et société*, p. 364.

⁴¹⁵ Renouard, *Répertoire des imprimeurs parisiens, libraires, fondateurs de caractères et correcteurs d'imprimerie*, p. 415. See also Laurent Guillo, *Pierre I Ballard et Robert III Ballard, imprimeurs du roy pour la musique (1599-1673)* (Sprimont and Versailles: Éditeur Pierre Mardaga and Centre de Musique Baroque de Versailles, 2003), pp. 94-95 for discussion of the Ballard house and its relation to the Le Bé house.

⁴¹⁶ Martin, *Livre, pouvoirs et société*, p. 364

family. The inventory lists some 30 editions for the period 1551 to 1598 (Adrian Le Roy and Robert I Ballard), and some 120 editions for the period 1599 to 1639, during which one would expect to find the more intensive use of the Le Bé music types.⁴¹⁷

The first description of the Le Bé music types appeared in 1766 in a small publication written by 'MM. Gando, père et fils'.⁴¹⁸ This was the punchcutter and typefounder Nicolas Gando (c. 1700 -1767) and his son Pierre-François Gando (1733-1800), also a punchcutter and typefounder, and was a riposte to the earlier publication of 1760 by Pierre-Simon Fournier⁴¹⁹ (1712-1768) which had denigrated both Gando father and son ('qui ne sont graveurs ni l'un ni l'autre, mais seulement Fondeurs') and accused them of plagiarism ('double plagiat de leur part'). Fournier did confirm that 'Guillaume le Bé, Graveur, Fondateur & Imprimeur, grava plusieurs Caractères de Musique & de la Tablature de Luth, in 1544 et 1545'. He added that 'ce caractères étoient faits pour être imprimés à deux fois, d'abord les filets, ensuite les notes, par rentrées les uns sur les autres. Ceste sorte de Caractères de Musique n'a pas eu d'autres succès; elle a été abandonnée comme sujette à trop d'inconvénients'.⁴²⁰

Fournier also mentions a legal case brought by Robert II Ballard against Guillaume II Le Bé and Jacques de Sanlecque father and son (père et fils) in February 1640 to prevent them from printing music and thus breaking the monopoly long held by the Ballard family. In a further paragraph, Fournier attributes the core of the Ballard music types to Le Bé ('Guillaume le Bé, fils de celui qui avoit fourni plusieurs Caractères de Musique qui formoient le fonds dudit Ballard'). As we know from the various polemical letters published earlier in the *Mercure de France* and the *Journal des Sçavans*, it is more than likely that Fournier was speaking from actual documentary evidence, as well as being the owner of the remains of the Fonderie Le Bé, which had passed into the possession by Jean-Pierre Fournier (Fournier l'Aîné).

The Gando publication confirms the Fournier text, but also adds some technical information as to how the characters were to be printed: 'Le Bé a gravé quelques caractères de musique pour Adrian le Roy & Robert Ballard, pour être imprimés à une seule fois, & il n'a gravé que les poinçons d'une grosse musique; & une tablature de luth pour être imprimée à deux fois'. Gando also explains the relative scarcity of printed examples of these types: 'Ses matrices, à la vérité, ne paroissent pas avoir pas avoir beaucoup servi; elles ont été conservées chez M. Ballard'. The table at the end of the text shows five specimens (A, B, C, D and E), of which specimen A is attributed to Guillaume I Le Bé (Grosse Musique pour être imprimée à deux fois), and

⁴¹⁷ Laurent Guillo, 'La bibliothèque de musique des Ballard d'après l'inventaire de 1750 et les notes de Sébastien de Brossard', *Revue de musicologie*, 90/2 (2004), pp. 287-288

⁴¹⁸ Nicolas Gando and Pierre François Gando, *Observations sur le traité historique et critique de M. Fournier le Jeune* (Berne and Paris: Chez Moreau, Libraire-Imprimeur, 1762)

⁴¹⁹ Also known as Simon-Pierre Fournier

⁴²⁰ Pierre-Simon (le Jeune) Fournier, *Traité historique et critique sur l'Origine et le progres des caracteres de fonte pour l'impression de la musique* (Paris et Berne: Chez Barbou, 1765), pp. 6-8. I am grateful to James Mosley for the use of his unpublished *Dictionary of Punchcutters for Printing Types* for clarification of the often confusing family names of the Fournier and Gando dynasties of punchcutters.

Specimen C (Grosse musique), which appears to be a single impression type, as the breaks between the various notes and staves are quite distinct. Specimen A appears to be identical to the specimen on NAF 4528, which is a setting of Psalm 16, and part of a Huguenot/Protestant psalm book.



Fig. 3.6: Page from *Observations sur le traité historique et critique de M. Fournier le Jeune*, 1762

The recent study and analysis of the music editions produced by Pierre I Ballard et Robert III Ballard by Laurent Guillo lists five music types cut by Le Bé which were

part of the Ballard foundry. The following is a summary of these types and their attributes:⁴²¹

Code	Style	Dimensions per 5 lines	Punchcutter	First Use	Mentioned in documents
GMF1 = grosse musique de fer le lance	Note en fer de lance (ou losangée)	14.7 mm	Le Bé	1555	Le Bé BnF MSS Ballard Inventory 1698 Gando 1766 'C' Wekerlin 1865 <i>Vente de Marchandises</i> (MC XI, 240 dated 7 octobre 1672)
GMF2 = grosse musique de fer le lance en deux impressions	Note en fer de lance (ou losangée)	14.7 mm	Le Bé	1557	Le Bé BnF MSS Gando 1766 'A' Wekerlin 1865 <i>Vente de Marchandises</i> (MC XI, 240 dated 7 octobre 1672)
GPC = Gros-Plain Chant	Plain-Chant (notes Carrés pleines)	15.0 mm	Le Bé	1557	Ballard Inventory 1698 Ballard Inventory 1750? Gando 1766 'A' Wekerlin 1865
GTE = Grosse Tablature d'épinette en ove	Note en ove (arrondie)	14.7 mm	Le Bé	c. 1555?	Le Bé BnF MSS Gando 1766 Wekerlin 1865
MMO = Moyenne musique en ove	Note en ove (arrondie)	10.5 mm	Le Bé	c. 1559	Le Bé BnF MSS Ballard Inventory 1698 Ballard Inventory 1750

Fig. 3.7: Tabular list of the Le Bé Music types (From Laurent Guillo, *Pierre I Ballard et Robert III Ballard, imprimeurs du roy pour la musique 1599-1673*, p. 209)

Guillo also discusses in some detail the two methods of composition used for music types. The first technique he calls *composition en emboîtement*, which could be translated as 'nesting'. In essence this procedure would consist of casting separate elements of notes and staves, which would then be fitted together to form a complete five-line staff with notes, clefs and rests. The second technique he calls *composition en juxtaposition*, which would consist of casting each separate element on a five line staff. The 'composition en emboîtement' would require fewer punches and matrices and also produce a more even effect, fewer breaks in the lines. Guillo notes that

⁴²¹ Guillo, *Pierre I Ballard et Robert III Ballard, imprimeurs du roy pour la musique*, p. 209. The *Vente de Marchandises* (MC XI, 240 dated 7 octobre 1672) which lists the tools, punches, matrices and types sold by Marie Robinot to Christophe Ballard in 1672, a few months before the death of Robert III Ballard. This document mentions 'trente sept poinçons de grosse musique pour les messes de la taille de Guillaume Lebé aveq une boiste carrée' and 'vingt quatre poinçons d'une grosse sans regletz de la taille dud. Lebé, aveq vingt neuf matrices de la justification et quatre poinçons aveq autres cinq matrices de grosses nottes'. I am grateful to Laurent Guillo for bringing this document to my attention.

'l'atelier Le Roy et Ballard employa l'emboîtement dans toute sa production et dès la première décennie de l'existence de l'atelier', yet the specimens on Folio 23v-24 in NAF 4528 appear to have used the second procedure.⁴²² There also has been a suggestion that kerning was used to build up a composite staff of lines and notes, but 'a font with kerned variants was expensive and time-consuming to design and cut as well as to set'.⁴²³

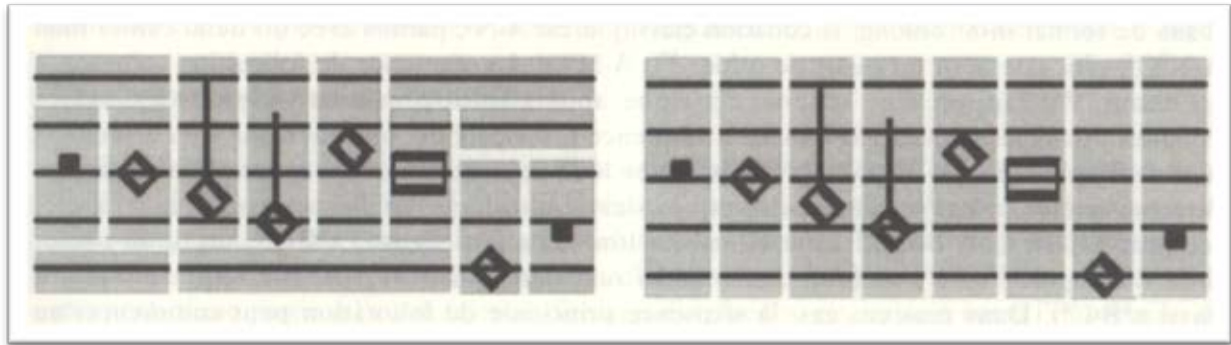

Fig. 3.8: Two methods of composition used for music types (By permission of Laurent Guillo, *Pierre I Ballard et Robert III Ballard, imprimeurs du roy pour la musique 1599-1673*, p. 229) Left: composition en emboîtement and right: composition en juxtaposition

The nineteenth-century French musicologist and archivist Jean-Baptiste Wekerlin wrote a series of articles in the Parisian music Journal *Le Ménestrel* in 1868 which explored in some detail the history of printing for music. As these articles were written before the Omont descriptions of the Le Bé documents were published, Wekerlin would have relied on existing biographical data for information on Le Bé, such as Lottin's *Catalogue Chronologique des Libraires et des Libraires-Imprimeurs*, which appeared in 1789. This would explain the misinterpretation of the dates of Le Bé's period of professional activity in Paris, which Wekerlin puts at between 1539 and 1555. Lottin in fact places these dates more accurately as between 1552 and 1598.⁴²⁴

Wekerlin notes Le Bé's 'poinçons pour les notes' in 1540, which is probably a misreading for 1555, and the 'tablatures' for Lute of 1544 and 1546. He supposes that Le Bé produced punches both for double impression, in which the staves (*la portée*) were printed separately, and then notes printed in a separate iteration, as well as punches combining both the notes and staves. This followed, according to Wekerlin, the method invented by the Parisian punchcutter Pierre Haultin (c. 1510 - 1578), in which 'la note et les filets (fragment de portée) se trouvaient sur le même poinçon, différant en cela du procédé de Petrucci, dont l'impression se faisait en deux fois ... les portées, puis les notes'. Vervliet, citing Fournier le Jeune, mentions that

⁴²² *Ibid.*, pp. 199-229

⁴²³ Duggan, *Italian music incunabula: printers and type*, pp. 33-34

⁴²⁴ Augustin Martin Lottin, *Catalogue chronologique des Libraires et des Libraires-Imprimeurs de Paris* (Paris: Jean-Roch Lottin, 1789), p. 246

Haultin cut Pierre Attaignant's earliest single impression music in 1528, and not in 1525 as reported by Wekerlin.⁴²⁵

Wekerlin then pursued this interest in Le Bé's types one step further. The last in the line of the Ballard dynasty, Christophe Jean François II Ballard (1772-1825) had died without succession and the type material came into the possession of Thérèse Bauche, his widow. She remarried into the Vinchon family, who eventually sold the press to the Imprimerie Charles de Mourgues Frères in 1855, who continued the printing business in Paris from the 1850s until at least the 1870s.⁴²⁶ Wekerlin was keen to satisfy his desire to 'retrouver quelques anciens poinçons de notes' and was able to find hidden away in the printers two bags of punches, many of which he immediately established as coming from the hand of Guillaume I Le Bé, as well as others from other punchcutters which had been acquired during the many years of the Ballard dynasty.⁴²⁷ The total number he estimated at some five to six hundred. He reproduced in an article the most characteristic of them, which he divided into six groups. The certainty with which he attributes these punches to Le Bé can be put down to his knowledge of the 1766 Gando brochure, which he cites in his footnotes.

The types in groups A and B consist of integrated note and staves, for a single impression, and Wekerlin describes them as having a 'forme barbare' and suggests that 'c'était là le premier essai de Le Bé' and that they might even be from the hand of Pierre Haultin. It is worth noting that these specimens have respectively four, nine and seven lines of staves, which is not the case in the music specimens in the BnF documents, all of which have five or six lines of staves.

⁴²⁵ Wekerlin, *Histoire de l'impression de la musique en France*, pp. 265-267. See also Vervliet, *French Renaissance Printing Types: A Conspectus*, pp. 42-43

⁴²⁶ Aubin Leroy and Régine Malveau, 'Le Fonds Ballard-Vinchon 1568-1887' (2005) <<http://archives.cg37.fr/UploadFile/GED/SerieJ/1178540575.pdf>> [Accessed 12 January 2013], pp. 3-7

⁴²⁷ Wekerlin, *Histoire de l'impression de la musique en France*, pp. 266-267

Spécimens de Guillaume Le Bé.

A.

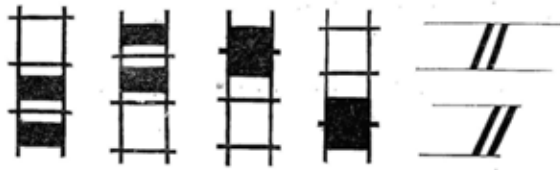

B.



C.

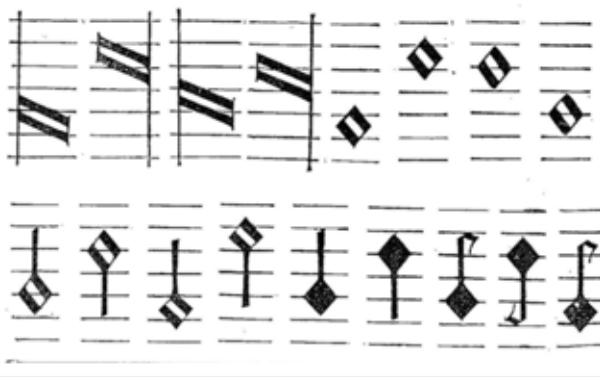

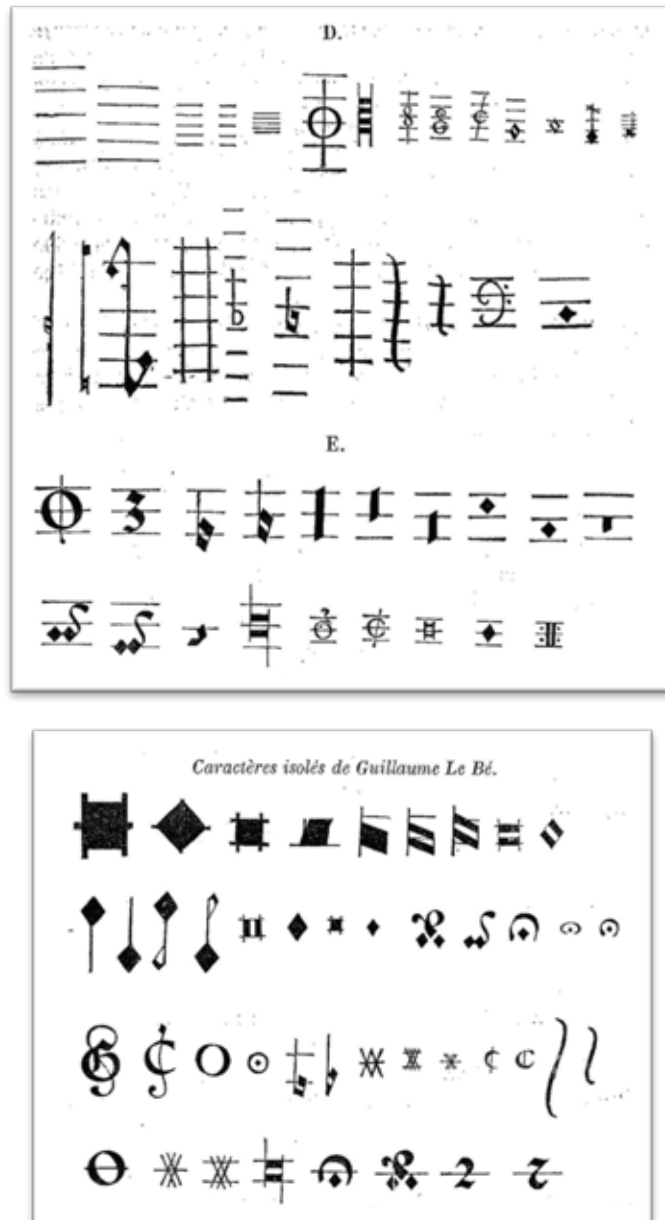

Fig. 3.9: Music types attributed to Guillaume I Le Bé from J-B Wekerlin (Actual size)

Unfortunately this important collection of historic punches has totally disappeared and left no trace. It is to be hoped that they were not destroyed and may yet be found in some archive, but we must be grateful to Wekerlin for his discovery and for his partial description of what he found.

Laurent Guillo has noted that 'il est frappant de constater que beaucoup de graveurs de caractères exotiques ont aussi travaillé à graver des caractères de musique', and he mentions as examples Robert Granjon, Nicolas Du Chemin, Guillaume I Le Bé, Jan Jannon and Hendrik Van den Keere. He also notes that this illustrates 'le degré de

specialisation similaire existant entre les domaines des langues exotiques et de la musique, tant pour la taille de caractères que pour l'impression des ouvrages'.⁴²⁸

To summarise this discussion of the music types of Guillaume I Le Bé, we are left with the impression of a skilled craftsman able to tackle the more complex procedures of punch cutting and type manufacture, i.e. music, Hebrew and Greek typefaces. Le Bé surely had more than a cursory knowledge of the linguistic and scribal requirements, as well as a detailed understanding of the technical aspects of casting and composition.

It is not in the scope of this thesis to explore these themes and connections in greater depth, but what they reveal is a far more complex and involved picture of Le Bé both in his family and business environments than what might be surmised from the Bibliothèque nationale de France documents alone.

We now proceed to an analysis of the Hebrew types produced by Guillaume I Le Bé following his return to Paris from Venice, excluding the Latins, Greek and Music types. These are shown for reference in the facsimiles in Appendices C and D.

⁴²⁸ Laurent Guillo, 'Problèmes généraux d'édition musicale', in *Le concert des voix et des instruments à la Renaissance: actes du XXXIVe colloque international d'Etudes humanistes (Tours, CESR, 1-11 juillet 1991)* (Paris: CNRS, 1995), p. 113

Hb11 (S)

Appears on NAF 4528 folio 8

Size: Unidentified on specimen; Vervliet gives as Great Primer or Gros-Romain; Plantin Moretus gives as Vrai texte Hébreu, façon de Venice

Type Classification: Square Sephardic pointed and unpointed

Measurements x-height of 2.5 mm (Vervliet gives as 2.8 mm); 10 lines = 53 mm

Date of creation: 1551 in Paris (His ninth numbered)

Punchcutter: Guillaume I Le Bé for Claude Garamont

First Appearance: *Shirei Musar HaSekhel* (Cantica Eruditionis Intellectus), Paris, Guillaume Morel, 1561

Type specimens: Plantin's *Index Characterum* 1567, Folio A3, Fournier Epreuves des Caractères à l'Usage de l'Imprimerie, Paris 1767 (Hébreu de Gros Romain) on folio 68 of MS 22189 of the Collection Anisson.

Material Preserved: Antwerp, MPM MA72; Deberny-Peignot MA 15216 at the Cabinet des Poinçons, Ivry?

Literature: Vervliet, *Conspectus*, 2011, p. 407, *Letters Proeven*, 2004, pp. 56-57, *Le Bé Inventaire après décès c. 1617* (Hébreu Gros Romain) – probable attribution

This is the first type cut by Le Bé in Paris after his return from Venice and his ninth according to his own count. It carries with it an interesting history and list of connections.

The annotation dates this specimen to the summer of 1551 and indicates that it was made in the house of Claude Garamont in the rue de Carmes.⁴²⁹ It may well be asked why Le Bé makes this statement, given that the marriage contract of Le Bé is dated 1st March 1551, the contract for the purchase of the house in the rue St. Jean de Beauvais is dated to the 15th of March, and finally given that the address on the marriage contract is given as rue St. Jehan de Beauvais. Note also that Le Bé writes 'apres mon retour d'Italie et de Troyes'. We know from the *Le Bé Memorandum* that he passed through Geneva on his return from Italy, where Robert Estienne provided him with letters both to Garamont and other type founders and printers, as well as to Guillaume Le Bé the elder, his father, in which Estienne asked the father to continue to supply paper to the two Estienne sons (Robert II and Charles) who had remained in Paris. To confuse matters further, the section on Garamont in the *Le Bé Memorandum* states that Le Bé returned to Paris 'a la fin de lan 1550 demeura un an ou environ chez ledit Garamond en sa susditte maison de la boulle Ruë de Carmes, ou il grava cest Hebreu de Gros Romain ...' These dates would place him in Garamont's house until roughly the *end* of 1551.⁴³⁰

This may be explained by a simple lapse of memory on the part of Le Bé I, and probably so on the part of Guillaume II Le Bé, the presumed author of the *Le Bé Memorandum*, composed in 1643, some fifty year after the death of his father. Guillaume Le II Bé notes that he had in his possession the letters from Estienne, but had destroyed them, 'ne jugeant pas estre necessaires'. Thus one may assume that

⁴²⁹ See page 410 of this thesis.

⁴³⁰ Le Bé, *The Le Bé memorandum*, pp. 18,21-22

such letters were dated and that they would have provided more information as to where Le Bé lived after his return from Italy. The confusion may also be explained by the change from old style to new style calendar, which took place in France in 1582.

Le Bé notes that the fount was cut 'pour le Sieur Claude Garamond'. That is to say, it was cut for the use of Claude Garamont, and continues the pattern that Le Bé established in Rome, where his founts were produced for other printers, and not for his own use. It implies also that at this stage the Le Bé foundry did not yet exist. By 1565-1566 Le Bé noted that he cut his founts 'pour moy'.

The annotation also notes that this fount was used by the printer Jean Bienné (Ioannes Benenatum) who was active from 1566 until his death in 1588, and married the widow of Guillaume Morel, from whom he is most likely to have inherited all his types and printing equipment.⁴³¹ Renouard attributes this typeface to two publications printed by Jean Bienné: the *De Sancta Trinitate* of Gilbert Génébrard of 1569 and the *Novum Testamentum* of 1584,⁴³² but he does add that the Hebrew in this later edition belonged to the printer Etienne Prevosteau, and this more than likely means that Prevosteau was a business associate of Morel and married Morel's daughter. Indeed Lyse Schwarzfuchs notes that Prevosteau continued 'à imprimer de l'hebreu jusqu'en 1596 avec les caractères de son beau-père.'⁴³³ Prevosteau's name appears on the colophon of the *Novum Testamentum* as 'Excudebat Steph. Prevosteau, Ioann. Bene_nati sumptibus & labore'.⁴³⁴

Le Bé's association with Claude Garamont continued until the death of the latter, as Le Bé was one of two type founders asked to prepare the inventory of Garamont's foundry in 1561. This inventory was mentioned by Jean-Pierre Fournier in a letter he wrote to the *Mercure de France* in 1756 and in which he described the inventory as follows: 'L'inventaire, la prisee & la vente que Guillaume le Bé & Jean le Sueur, autre fondeur de caracteres, firent de la fonderie de Garamond après son décès, le 18 Novembre 1561, à la Requête de Dame Isabeau Lefevre, veuve de feu sieur Claude Garamond, en son vivant, Graveur de lettres, & Maître à Paris, & de sieur André Wechel, Marchand Libraire, Juré au-dit lieu, executeurs du Testament dudit défunt'.⁴³⁵ Quite a few documents relating to Garamont have been found, including his will dated September 1561.

This inventory appears to have been lost.⁴³⁶ Le Bé's name is not mentioned, but André Wechel ('honorable homme André Wechel, marchand libraire juré bourgeois de Paris') is named as an executor of the will (*exécuteur testamentaire*).⁴³⁷

⁴³¹ Renouard, *Imprimeurs parisiens, libraires, fondeurs de caractères et correcteurs d'imprimerie*, pp. 28-29. See also Renouard, *Imprimeurs & libraires parisiens du XVIIe siècle*, p. 458

⁴³² Renouard, *Imprimeurs & libraires parisiens du XVIIe siècle*, p. 459

⁴³³ Schwarzfuchs and Coron, *Le livre hébreu à Paris au XVIIe siècle*, p. 43

⁴³⁴ Printed by Etienne Prevosteau at the expense and labour of Jean Bienné

⁴³⁵ The description by Jean-Pierre Fournier appears in a Lettre de M. Fournier, l'aîné', *Mercure de France*, mai 1756, p. 123. The original draft is to be found in the BnF, the Collection Anisson Fr. 22117, folios 30 –31.

⁴³⁶ I am indebted to James Mosley for drawing my attention to this document in an unpublished note.

Wechel is mentioned in the final paragraph of the annotation as having purchased the punches for this typeface and taken them to Germany. André Wechel, nephew of the printer Chrétien Wechel, was of Flemish origin and was active as a publisher and printer in Paris from about 1554 to 1572, when he was forced to flee to Frankfurt am Main due to his Protestant leanings, following the St Bartholomew's Day Massacre. Chrétien Wechel did publish over 30 full or partial Hebrew editions, but André Wechel was only involved in an edition of Ludovico Carreto in 1554, after which Lyse Schwarzfuchs comments that he 'ne devait plus publier en hébreu après ce livre'.⁴³⁸ An edition from 1556 has since come to light which bears the colophon of André Wechel in Paris with the occasional use of Hebrew within the text, but the Hebrew type used is most probably that of Gryphius (1531).⁴³⁹

André Wechel did in fact publish two books containing Hebrew characters following the re-establishment of his press in Frankfurt. The first is the *Bibliorum Pars Tertia id est Quinque Libri Moschis*, printed in 1579, which uses Hebrew initials letters in Lam. 1-3. The Hebrew used in this edition is a 4 mm Ashkenazic, very similar in fact to the specimen shown in Res X 1565 f^o. 22, and not one of Le Bé's founts.⁴⁴⁰ The second edition is the *Testamentis Biblia Sacra*, printed in Geneva in 1590 by Jean II de Tournes, but with the imprint 'Impensis (sic) And. Wecheli Haeredum'.⁴⁴¹ It uses a Hebrew in the *Annotatio*, but this Hebrew once again is not a Le Bé fount, but most probably a Bomberg fount.⁴⁴²

Thus Le Bé, lacking either the matrices or punches for this typeface, was forced to purchase a set of strikes and borrow the punches from Wechel's widow, which must

⁴³⁷ Guilleminot-Chrétien, 'Le Testament de Claude Garamont', in *Le livre et l'historien: Etudes offertes en l'honneur du Professeur Henri-Jean Martin*, ed. by Martin and Barbier (Geneve: Librairie Droz, 1997), p. 134. See also Parent and Veyrin-Forrer, 'Claude Garamont: New Documents', .

⁴³⁸ Schwarzfuchs and Coron, *Le livre hébreu à Paris au XVIe siècle*, p. 39.

⁴³⁹ Jean de Neufville, *Ioannis Neovillei Genvillani in septem Davidis Psalmos quos poetentiales vocant, commentarii* (Paris: André Wechel and Galiot du Pré, 1556). I am grateful to Geneviève Guilleminot of the BnF for calling my attention to this edition and to Lyse Schwarzfuchs for her useful contribution as to the attribution of this fount.

⁴⁴⁰ Francois the elder Du Jon and Joannes Immanuel Tremellius, *Bibliorum pars tertia, id est, quinque libri Moschis. (Pars secunda, id est, libri historici, etc.-Pars tertia, id est, quinque libri poetici, etc.-Pars quarta, id est, prophetici libri omnes, numero xvi., etc.) Latini recens ex Hebræo facti, brevibusque scholiis illustrati, ab Immanuele Tremellio & Francisco Iunio. (Libri Apocryphi, sive appendix Testamenti Veteris ... latina ... facta, & notis brevibus illustrata per F. Iunium.)* (Francofurti ad Moenum: A. Wechelus: , 1579) (BL 463c8)

⁴⁴¹ Théodore de Bèze, Francois the elder Du Jon, and Joannes Immanuel Tremellius, *Testamenti Veteris Biblia sacra, sive, libri canonici ... Latini ... facti ... ab Immanuele Tremellio & Francisco Junio. Accesserunt libri qui vulgo dicuntur Apocryphi, Latine redditi ... a F. Junio ... Quibus etiam adjunximus Novi Testamenti libros ex sermone Syro ab eodem Tremellio, & ex Græco a Theodoro Beza in Latinum versos ... Secunda cura F. Junii*. Vol. 6 pt. (Genevæ: apud I. Tornæsium: Genevæ; impensis A. Wecheli hæredum, C. Marnii & I. Aubrii: Francofurdi, 1590) (BL 3020e8). See also Schwarzfuchs, *L'hébreu dans le livre à Genève au XVIe siècle*, pp. 206-207

⁴⁴² For discussion of the transmission of the Le Bé types to Frankfurt see Morison and Carter, *John Fell, the University Press and the "Fell" types*, pp. 126-128

have taken place after the death of André Wechel in 1581.⁴⁴³ The fate of these punches is not known.

Le Bé does record that the matrices and mould of this typeface were sold to Christophe Plantin, following the sale of his *meubles* – most probably meaning his household goods. This could either indicate the sale of Garamont's household possessions following his death in 1561 or possibly those of Plantin following the period when Plantin had returned to Paris (1562 to 1563) to escape possible persecution for his unorthodox religious beliefs, and prior to the partnership with Cornelis and Karel van Bomberghen, Johannes Goropius Becanus and Jacopo Scotti.⁴⁴⁴ Plantin might have been in Paris during the sale of Garamont's foundry and could have purchased these matrices and relevant moulds at that time. Harry Carter believes that the theory that Plantin bought a large amount of matrices offered for sale 'does not square well with the Plantin records' and links these matrices and moulds specifically to the typeface in question – Hb11(S). He adds that 'clearly he [Le Bé] is talking only about the punches, matrices and moulds for a particular type and the reason why moulds is plural is that a pointed Hebrew needed more than one mould'.⁴⁴⁵

There is little doubt that the matrices at present in the Plantin Moretus Museum (MA72) are indeed the typeface described in the document. The actual mould is not so easy to identify and no specific mould appears to be related to this typeface.⁴⁴⁶ The various inventories in the Plantin Moretus archives are quite specific on this point and leave no doubt that this transaction did take place. In total this typeface is mentioned in the following inventories: 1563, 1566, 1572, 1612 and 1652. For example, the inventory of 1566 lists 'les matrices and poinssons taillé de Guillaume Le Be (sic) de l'hebrieu sur le texte avec 3 *instruments* (my italics), and these relate to MA 72 and ST52. The inventory of 1572 has under the heading 'Moules ou Instruments' 'et outre ceulx cy – meaning those other moulds for Roman and Greek typefaces – les moules de l'Hebrieu et les accents qui sont aupres des matrice en la boîte', but does not specify the exact size or number of the moulds. Finally, the 1581 inventory lists eight 'moules de L'Hebrieu et ses accents qui sont ensemble en 2 boites'.⁴⁴⁷

The actual specimen is a page from the didactic poem *Musar HaSekhel* (Ethics of Morality), thought to have been written by the tenth-century Jewish scholar and commentator Hai Ben Sherir Gaon of Pumbedita in modern Iraq (939 –1038).⁴⁴⁸ The first edition of this work appeared about 1505 in Fano and others were published

⁴⁴³ William Lefanu, 'André Wechel', *Huguenot Society Proceedings* (1966)

⁴⁴⁴ Colin Clair, *Christopher Plantin* (London: Cassell, 1960), pp. 37-38

⁴⁴⁵ Harry Carter, 'Plantin's types and their Makers', *De Gulden Passer*, 34 (1956), pp. 131-132

⁴⁴⁶ Parker, 'Early Typefounder's Moulds in the Plantin-Moretus Museum', pp. 101-102

⁴⁴⁷ Parker, Melis, and Vervliet, 'Typographica Plantiniana II', pp. 25, 36, 69

⁴⁴⁸ Sherira Hai ben, Jean Mercier, and Jehoseph ben Hanan ben Nathan Ezobi, *Shire musar haSechel* (Parisiis, 1559) Exact page found in 1982c36(2) in the BL.

in 1531 in Constantinople and later in 1561 in Paris.⁴⁴⁹ This Paris edition was printed by Guillaume Morel during the period 1559 to 1561: the date on the colophon reads 1561, whereas the Hebrew date reads 1558. Morel was active as a bookseller and printer during the period 1548 to 1564 and has nine Hebrew editions to his name. Lyse Schwarzfuchs writes that 'ses impressions hébraïques ... sont très soignées et les fautes y sont rares'.⁴⁵⁰ The colophon also notes that Morel was 'in graecu typographum Regium', a position which Morel took over from his former associate, Adrien Turnèbe, the 'imprimeur du roi en grec'.⁴⁵¹

The second paragraph of the annotation gives some idea of Le Bé's understanding and knowledge of Hebrew and the necessary characters required for a Hebrew typeface: 'daguetz, pointz et accents, lettres communes, lettres larges, demy larges et estroites'.⁴⁵² He also shows his awareness of the lack of hyphenation in biblical Hebrew setting – d'autant que les Hebreux n'usent point de division et separation des motz en la fin de ligne – and the slipshod composition methods practiced by many compositors when faced with Hebrew setting. This last point is often an indication that a text was set by non-Jews or at least by a compositor with minimal knowledge of Hebrew orthography and grammar. Such mistakes are common in some of the Le Bé specimens, for example the confusion between similar characters pairs – i.e the vav and the zayin, the heh and the chet, or the bet and the kapf, the incorrect placement of vowel points, or the incorrect use of final letters in medial positions. These problems were widespread in the sixteenth and seventeenth centuries. The example of in the *Apologia* by Avraham the son of Eliezer Brunschwig in the Rabbinical Bible printed by Johannes Buxtorf in Basle in 1618 has already been mentioned. Yet it also has to be said that such errors were not restricted to non-Jewish compositors. The example of David Portoleone's edition of *Shiltei HaGibborim* by the printer Moses Elishema Zifroni in Mantua in 1612 demonstrates that Jewish printers were equally capable of serious typographical mistakes. In his introduction to this volume Portoleone complains bitterly about the printer who repeatedly misplaced the character het 'while the letter bet has time and again been confused with the letter kaph'.⁴⁵³

Correct setting of Hebrew required a competent editor, such as in the case of the convert Felice da Prato or Felix Pratensis in the first Bomberg *Biblia Rabbinica* of

⁴⁴⁹ See 'Hai Ben Sherira' (<<http://www.jewishencyclopedia.com/articles/7051-hai-ben-sherira>> [Accessed 08 July 2011])

⁴⁵⁰ Schwarzfuchs and Coron, *Le livre hébreu à Paris au XVIIe siècle*, pp. 42-43

⁴⁵¹ *Ibid.*, p. 42

⁴⁵² dagesh, vowels and cantillations marks, basic letters, extended letters, wider and narrow set.

⁴⁵³ Michael Pollak, 'Some observations on printing in a Hebrew text dated 1612', *Gutenberg-Jahrbuch* (1976), p. 319

1517/1518,⁴⁵⁴ or the roles of Franciscus Raphelengius and Benito Arias Montano in the editing of the Plantin Polyglot Bible.⁴⁵⁵

Le Bé declares himself well satisfied with the end result (*fort artisement faicte*), well finished (*bien limée et polie*) and approved by others with greater knowledge than himself (*et au contentement de celuy qui en sçavoit plus que moy*). This may indicate that Jews well versed in the correct letter forms had seen and approved this typeface.

This is an appropriate point to raise the question whether Le Bé supplied matrices or strikes with what are sometimes called Portmanteau sorts. This is not a straightforward matter. These sorts take their name from the term ‘portmanteau’, which identifies a blend of two words to form a third with a new meaning. It was first coined by Lewis Carroll in *Through the Looking Glass*.⁴⁵⁶ The first use of the term as applied to typography is most likely in Morison’s work on the Fell Types in 1967.⁴⁵⁷

The application to typesetting is to produce a variety of diacriticals or accents on one matrice whose purpose is to cut down on the number of sorts which need to be produced or cast. In theory, once cast, the printer or compositor could file or cut off the unwanted accents. What then is the evidence for such a practice in the printer’s manuals? Moxon, the earliest English printers manual (1683) in *Mechanick Exercises on the Whole Art of Printing*, has no mention or description of such sorts, although he does discuss composition for Hebrew and Greek. Simon-Pierre Fournier in his *Manuel Typographique* (1764-1766) provided a much more detailed discussion of the setting of pointed Hebrew, and discussed how accented letters are struck in a matrice with stepped punches,⁴⁵⁸ but provided no description of this particular method.

The casting bill (‘register’ in Dutch) in Volume I of the *Manuel Typographique* for a pointed Hebrew fount does appear to show characters with a full set of points for most of the relevant characters. For example, the shin has six alternate sorts, one with a holem to the right, one with a holem to the left, one with Holem to both right and left, one with a dagesh and holem to the right, one with a dagesh and holem to the left and one with one with a dagesh and holem to the left and right.⁴⁵⁹ These may well be perfectly *bona fide* positions for dagesh and holem points in Hebrew, but they could also have been used as Portmanteau sorts to reduce the number of

⁴⁵⁴ Amram, *The makers of Hebrew books in Italy*, p. 156

⁴⁵⁵ The degree of the knowledge of Hebrew of both Montano and Raphelengius was noted by Anthony Grafton in his 2010 Panizzi lectures at the British Library. See Anthony Grafton, *The Culture of Correction in Renaissance Europe* (London: The British Library, 2011)

⁴⁵⁶ ‘Portmanteau Words’ (<<http://users.tinyonline.co.uk/gswithenbank/portmant.htm>> [Accessed 17 October 2013])

⁴⁵⁷ Morison and Carter, *John Fell, the University Press and the "Fell" types*, p. 241

⁴⁵⁸ Fournier and Carter, *Fournier on Typefounding*, pp. 84-85

⁴⁵⁹ A small dot above the character to represent a long ‘o’ sound.

characters cast.⁴⁶⁰ There do not seem to be descriptions from the period which either confirm or deny this point.

In the MA72 matrices for Hb11 (S) examined in the MPM in Antwerp, there are three instances of a character with double upper holem points: the aleph, dalet (ד) and shin. This may be evidence for the use of Portmanteau sorts, but are not conclusive given the large number of possible combinations in Biblical Hebrew setting.⁴⁶¹

A possible resolution to this issue would only be a diagram of the lay of the Hebrew case used by Fournier. Most standard cases would not have room for this many sorts. Gessner in 1743 shows a single case for Hebrew, with a similar assortment of pointed characters, some showing both the dagesh and holem. There are seven sorts shown for the shin, which could point to a possible Portmanteau sort. One of the sorts has three points above, which are most probably what are called *puncta extraordinaria* or Ezra's points.⁴⁶² The case also shows a full complement of individual points and cantillation marks, which presumably would have been cast on a smaller bodies.⁴⁶³

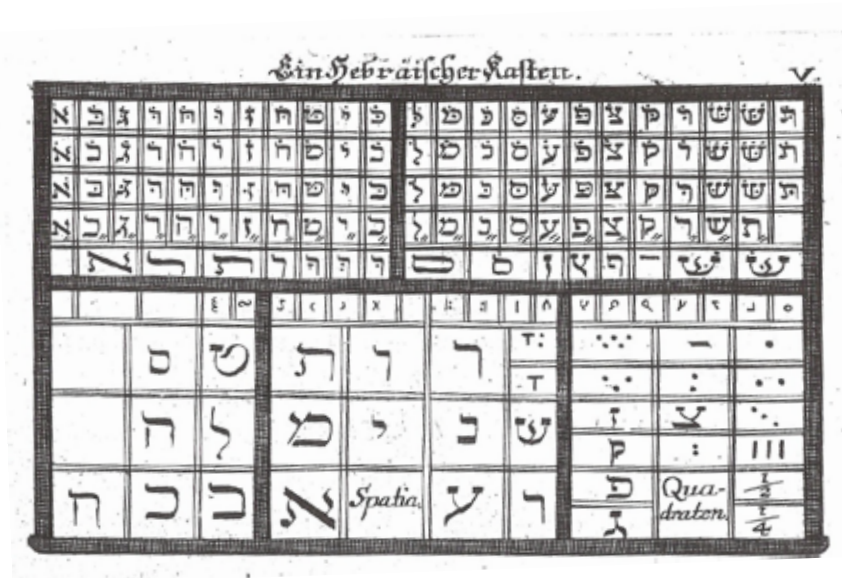

Fig. 3.10: Gessner 1743 Hebrew type Case. From *Der in der Buchdruckerei wohl unterrichtete Lehr-Junge*. BL 11899.bb.4.

Johann Ernesti (1733) shows a similar Hebrew type case, but with different positions for most of the characters. There are fewer sorts for the characters with dagesh and holem points, and once again a full complement of individual points and cantillation

⁴⁶⁰ As an example of the use of double upper points in the character shin, see the combination no. 276 in Appendix J on page 586, from Psalms 34. See also George Bush, *A Grammar of the Hebrew Language* (New York: Gould, Newman & Saxton 1839), p. 45 where an example is given of several words in which the initial shin has both a right and left holem point over the letter.

⁴⁶¹ See Appendix J for examples.

⁴⁶² See glossary for further details.

⁴⁶³ Christian Friedrich Gessner *et al.*, *Der in der Buchdruckerei wohl unterrichtete Lehr-Junge; oder: Bey der löblichen Buchdruckerkunst nöthige und nueliche Anfangsgründe* (Leipzig, 1743)

marks. In addition, there are a series of type boxes marked *Accente* whose purpose is not made clear from the accompanying text.⁴⁶⁴

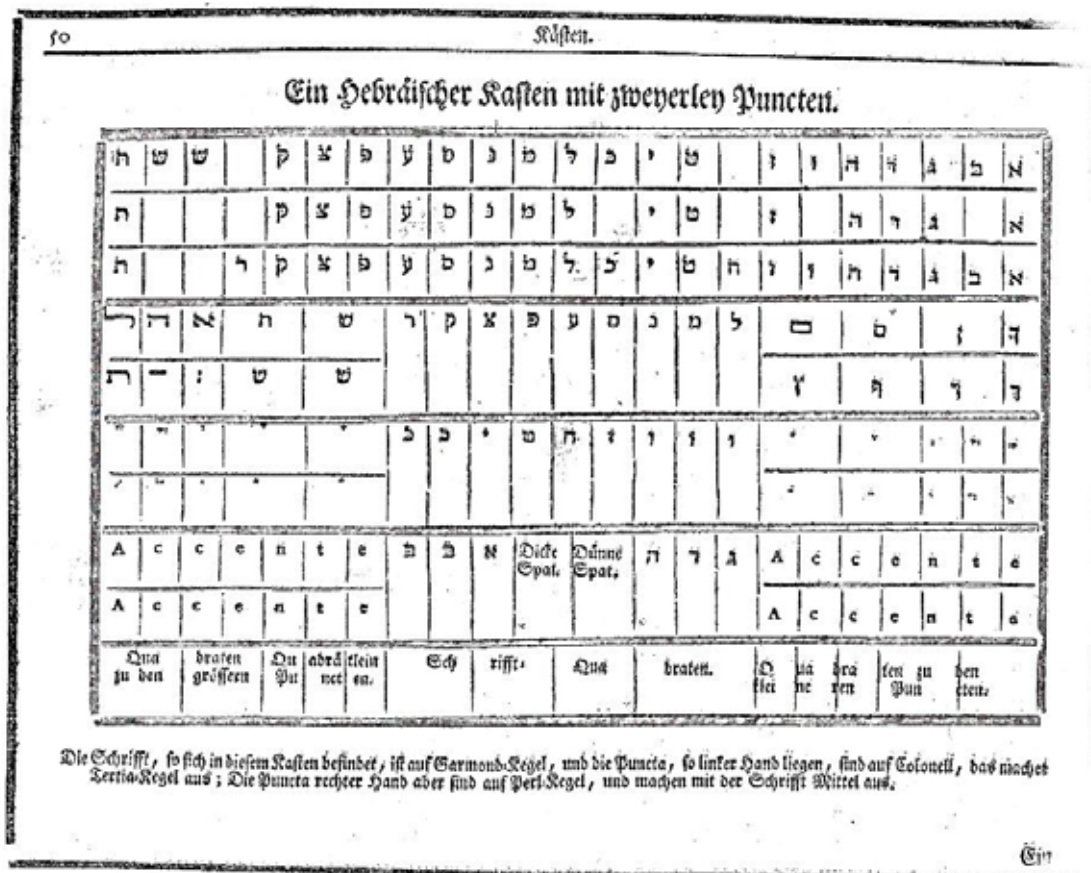

Fig. 3.11: Ernesti 1733 Hebrew type Case. From *Die Wol-eingerichtete Buchdruckerey*. BL 53.b.28

Johnson in his *Typographia* shows three variations of the Hebrew type case: an upper and lower case (for pointed setting) and what he calls a common Hebrew case for unpointed setting. The lower case contains separate vowel points, whereas the upper show shows the most common cantillation marks as individual sorts. There are fewer instances of what one could clearly identify as well as Portmanteau Sorts. He also shows a single case Common Hebrew Case without any accents. Note the six extended characters and the aleph/lamed ligature in the upper case. The seven left hand boxes in the lower case are labelled as containing spaces for justifying the points, which may well have been a feature of sixteenth-century Hebrew type cases.⁴⁶⁵

⁴⁶⁴ Johann Heinrich Gottfried Ernesti and Erhard Reusch, *Die Wol-eingerichtete Buchdruckerey, mit hundert und ein und zwanzig Teutsch- Lateinisch- Griechisch- und Hebräischen Schriften, vieler fremden Sprachen Alphabeten, musicalischen Noten, Calender-Zeichen, und Medicinischen Characteren, ingleichen allen üblichen Formaten bestellet, und mit accurater Abbildung derr Erfinder der löblichen Kunst, nebst einer summarischen Nachricht von den Buchdruckern in Nürnberg, ausgezieret. Am Ende sind etliche kurz-gefasste Anmerkungen von der Hebräischen Sprach angefüget* (Nürnberg: Johann Andreä Endters seel. Sohn und Erben, 1733)

⁴⁶⁵ J. W. Johnson, *Typographia, or the printers instructor* ([S.l.]: [s.n.], 1824), pp. 272-274 (Vol. II)

HEBREW UPPER CASE.

א	ב	ג	ד	ה	ו	ז	ח	ט	י	כ	ל	מ	נ	ס	ע	פ	צ	ק	ר	ש	ת
א	ב	ג	ד	ה	ו	ז	ח	ט	י	כ	ל	מ	נ	ס	ע	פ	צ	ק	ר	ש	ת
א	ב	ג	ד	ה	ו	ז	ח	ט	י	כ	ל	מ	נ	ס	ע	פ	צ	ק	ר	ש	ת
א	ב	ג	ד	ה	ו	ז	ח	ט	י	כ	ל	מ	נ	ס	ע	פ	צ	ק	ר	ש	ת
א	ב	ג	ד	ה	ו	ז	ח	ט	י	כ	ל	מ	נ	ס	ע	פ	צ	ק	ר	ש	ת
א	ב	ג	ד	ה	ו	ז	ח	ט	י	כ	ל	מ	נ	ס	ע	פ	צ	ק	ר	ש	ת
א	ב	ג	ד	ה	ו	ז	ח	ט	י	כ	ל	מ	נ	ס	ע	פ	צ	ק	ר	ש	ת
א	ב	ג	ד	ה	ו	ז	ח	ט	י	כ	ל	מ	נ	ס	ע	פ	צ	ק	ר	ש	ת
א	ב	ג	ד	ה	ו	ז	ח	ט	י	כ	ל	מ	נ	ס	ע	פ	צ	ק	ר	ש	ת
א	ב	ג	ד	ה	ו	ז	ח	ט	י	כ	ל	מ	נ	ס	ע	פ	צ	ק	ר	ש	ת
א	ב	ג	ד	ה	ו	ז	ח	ט	י	כ	ל	מ	נ	ס	ע	פ	צ	ק	ר	ש	ת
א	ב	ג	ד	ה	ו	ז	ח	ט	י	כ	ל	מ	נ	ס	ע	פ	צ	ק	ר	ש	ת

272...Typographia.

HEBREW LOWER CASE.

א	ב	ג	ד	ה	ו	ז	ח	ט	י	כ	ל	מ	נ	ס	ע	פ	צ	ק	ר	ש	ת
א	ב	ג	ד	ה	ו	ז	ח	ט	י	כ	ל	מ	נ	ס	ע	פ	צ	ק	ר	ש	ת
א	ב	ג	ד	ה	ו	ז	ח	ט	י	כ	ל	מ	נ	ס	ע	פ	צ	ק	ר	ש	ת
א	ב	ג	ד	ה	ו	ז	ח	ט	י	כ	ל	מ	נ	ס	ע	פ	צ	ק	ר	ש	ת
א	ב	ג	ד	ה	ו	ז	ח	ט	י	כ	ל	מ	נ	ס	ע	פ	צ	ק	ר	ש	ת
א	ב	ג	ד	ה	ו	ז	ח	ט	י	כ	ל	מ	נ	ס	ע	פ	צ	ק	ר	ש	ת
א	ב	ג	ד	ה	ו	ז	ח	ט	י	כ	ל	מ	נ	ס	ע	פ	צ	ק	ר	ש	ת
א	ב	ג	ד	ה	ו	ז	ח	ט	י	כ	ל	מ	נ	ס	ע	פ	צ	ק	ר	ש	ת
א	ב	ג	ד	ה	ו	ז	ח	ט	י	כ	ל	מ	נ	ס	ע	פ	צ	ק	ר	ש	ת
א	ב	ג	ד	ה	ו	ז	ח	ט	י	כ	ל	מ	נ	ס	ע	פ	צ	ק	ר	ש	ת
א	ב	ג	ד	ה	ו	ז	ח	ט	י	כ	ל	מ	נ	ס	ע	פ	צ	ק	ר	ש	ת
א	ב	ג	ד	ה	ו	ז	ח	ט	י	כ	ל	מ	נ	ס	ע	פ	צ	ק	ר	ש	ת

Typographia...273

N. B. The boxes on the left hand side of this case contain spaces and quadrats for justifying the points.
 * Query!—Would it not be more convenient to compositors in general, if the Hebrew lower case were laid as near as possible to the English method; this plan has been adopted by some compositors, who have acknowledged the great advantages resulting from such an arrangement. We had an idea of giving the scheme of such a case, but, upon mature deliberation, it was considered unnecessary.

COMMON HEBREW CASE.

א	ב	ג	ד	ה	ו	ז	ח	ט	י	כ	ל	מ	נ	ס	ע	פ	צ	ק	ר	ש	ת
א	ב	ג	ד	ה	ו	ז	ח	ט	י	כ	ל	מ	נ	ס	ע	פ	צ	ק	ר	ש	ת
א	ב	ג	ד	ה	ו	ז	ח	ט	י	כ	ל	מ	נ	ס	ע	פ	צ	ק	ר	ש	ת
א	ב	ג	ד	ה	ו	ז	ח	ט	י	כ	ל	מ	נ	ס	ע	פ	צ	ק	ר	ש	ת
א	ב	ג	ד	ה	ו	ז	ח	ט	י	כ	ל	מ	נ	ס	ע	פ	צ	ק	ר	ש	ת
א	ב	ג	ד	ה	ו	ז	ח	ט	י	כ	ל	מ	נ	ס	ע	פ	צ	ק	ר	ש	ת
א	ב	ג	ד	ה	ו	ז	ח	ט	י	כ	ל	מ	נ	ס	ע	פ	צ	ק	ר	ש	ת
א	ב	ג	ד	ה	ו	ז	ח	ט	י	כ	ל	מ	נ	ס	ע	פ	צ	ק	ר	ש	ת
א	ב	ג	ד	ה	ו	ז	ח	ט	י	כ	ל	מ	נ	ס	ע	פ	צ	ק	ר	ש	ת
א	ב	ג	ד	ה	ו	ז	ח	ט	י	כ	ל	מ	נ	ס	ע	פ	צ	ק	ר	ש	ת
א	ב	ג	ד	ה	ו	ז	ח	ט	י	כ	ל	מ	נ	ס	ע	פ	צ	ק	ר	ש	ת
א	ב	ג	ד	ה	ו	ז	ח	ט	י	כ	ל	מ	נ	ס	ע	פ	צ	ק	ר	ש	ת

274...Typographia.

Fig. 3.12: Johnson's *Typographia* 1824, Hebrew upper, lower and common type cases. From the Google Books digitised version

De Guigne's *Principes de composition typographique pour diriger un compositeur dans l'usage des caractères orientaux de l'imprimerie royale* (1790) does mention Portmanteau sorts, without using this term. He writes, when talking about the Arabic character Ta (ﺕ) that, 'dans ce caractère, on a suivi une marche toute opposé aux précédens pour tendre un même but, celui de diminuer le nombre des poinçons;

dans les premiers, on a communément supprimé les points: ici on en a mis une multitude à chaque figure: c'est ce qui a fait dire M. Pétis de la Croix,⁴⁶⁶ qui n'a rien entendu à ce système, faute de l'avoir examiné dans toutes ses parties, qu'il falloit rejeter ces caractères chargés de tant de points, parce qu'il ne conviennent ni au Turc, ni à l'Arabe, ni au Persan; c'est eût anéantir ce corps de caractères, que de suivre son avis. Mais en l'examinant avec attention, on aperçoit bientôt que ces petites lettres ou poinçons n'ont pas été faits inutilement, & qu'ils ne sont chargés de tant de points, que pour que le Compositeur supprime, suivant le mot qu'il veut imprimer, ceux de ces points dont il n'a pas besoin, on n'a pas été obligé de faire graver un nombre prodigieux de poinçons'.

De Guigne's discussion of Hebrew in the same edition is much shorter and notes that 'les voyelles Hébraïques, ainsi que les accens & les points orthographiques, se placent communément au-dessous des consonnes auxquelles elles ne tiennent point; c'est une seconde ligne ou ligne interlinéaire dont la composition est assez embarrassante à cause de la multitude de ces points & accens; mais c'est à l'auteur qui donne la copie, de les bien placer, pour diriger le Compositeur. *Dans ces caractères de Roi, il n'y a pas, comme en Arabe, de poinçons à double figure; tous sont isolés, c'est au Compositeur à les réunir*'. (my italics) This last comment (à double figure) may indicate that it was not the practice, at least in the Imprimerie Royale in the eighteenth century, to use Portmanteau Sorts for Hebrew. When discussing the character Dolat (ܐ) in Syriac, de Guignes notes that 'dans ces caractères du Roi on n'a fait que deux poinçons, une pour chacune de ces deux lettres, & ces deux poinçons présentent un point dessus & un point dessous, en sorte qu'en supprimant l'un ou l'autre, le Compositeur peut faire à son gré, ou un dolat, ou un risch'. De Guignes adds: 'Ceci est une preuve ce que j'ai dit en parlant de l'Arabe dans lequel on a chargé un caractère de points, lesquels le Compositeur est maître de supprimer à son gré, suivant le besoin ...' ⁴⁶⁷

As previously mentioned, Morison noted Portmanteau sorts in the Fell Canon Arabic. He wrote: 'the original set of punches left to the compositor the task of trimming off the type as many diacritical points from such portmanteau-sorts as  were superfluous to the character that he wanted, and there are a few punches to be completed by adding the diacritical mark "floating" in a line above them...' ⁴⁶⁸ They are also shown in the Appendix to the 1695 Oxford specimen, in relation to the extra

⁴⁶⁶ I am grateful to Geoffrey Roper for clarification on this point. Pétis de la Croix - 'was a celebrated Arabic, Persian and Turkish scholar' in the seventeenth century – and does not appear to have written a text which contained this specific reference, but 'his dissatisfaction with the actual or proposed founts may have had something to do with this'.

⁴⁶⁷ Joseph de Guignes, *Principes de composition typographique pour diriger un compositeur dans l'usage des caractères orientaux de l'imprimerie royale.*, 1790), pp. 19-20, 65-66. 71-72. This matrix could become either a 'resh' or a 'dalath', depending on which point was cut off.

⁴⁶⁸ Harry Carter confirms the use of Portmanteau sorts in his notes on the Fell material in Oxford. See Harry Carter, *Notes towards a specimen of the Ancient Typographical Materials principally collected and bequeathed to the University of Oxford, Fascicule IV: Exotic Types* (Oxford: Printed privately, 1957), p. 15

dotted letters in Persian, Turkish & Malay. These dots are usually referred to as *nuq̣ṭa* (plural: *nuq̣ṭat*) in Arabic. One issue with the use of Portmanteau Sorts in Arabic is that characters with one dots need to be centred, whereas 'if the lower two dots are removed from the triangular group of three, the remaining one, though centred, is too high'. The same issue could also occur in Hebrew with certain characters if Portmanteau sorts were employed.⁴⁶⁹

An alternate opinion on the subject of Portmanteau sorts in Hebrew composition is that by the time the type was sorted into the type case, the extraneous points had *already* been filed off. Furthermore, the definition of what makes a Portmanteau sort needs to be widened to cover such the deletion of unwanted dagesh points. This may indeed be correct, but it very much depends on the practices of individual printers, which is not the sort of information that has yet come to light.⁴⁷⁰

In summary, there appears to be clear evidence for the use of Portmanteau sorts in such 'exotics' as Arabic and Syriac, but a less conclusive argument for their use in Hebrew. Type engravers and type founders in the sixteenth century would have had a strong economic incentive to reduce the number of punches they had to produce and also the number of individual sorts they needed to cast for a complete setting fount. Added to this was the limitation of the size of the type case in use and the very basic knowledge of Hebrew grammar on the part of *most* compositors. The exception was in Italy where such printers as Soncino and Bomberg were known to have employed Jews in their print shops, or in for example where the Jewish printer Israel Zifroni worked for both Ambrosius Frobenius and Konrad Waldkirch in Basle. Unless we find specific descriptions to document the use of such sorts in Hebrew, the final answer to this question needs to be left open.

⁴⁶⁹ See Geoffrey Roper, 'Arabic Printing and Publishing in England before 1820', *Bulletin (British Society for Middle Eastern Studies)*, 12 (1985), p. 15. Email correspondence with Geoffrey Roper re Portmanteau Sorts, 13/07/2012.

⁴⁷⁰ I am indebted to Dr. J.F. Coakley for this alternate opinion.

The complete alphabet and key letter recognition factors

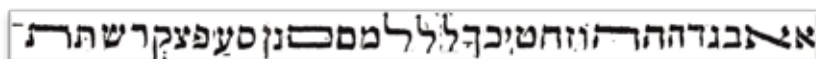

Fig. 3.13: Hb11(S) Complete assembled alphabet from the specimen at actual x-height of 2.5 mm.



Fig. 3.14: Hb11(S) Complete assembled alphabet from the specimen (MA72). Actual size. This specimen contains more sorts than are shown in the NAF 4528 specimen. Note the separate accents (Nikkud) and punctuation. (Museum Plantin-Moretus/Prentenkabinet)



Fig. 3.15: Hb11(S) Complete assembled alphabet from the specimen enlarged to approximate x-height of 10 mm.



Aleph: The Le Bé specimen has only one set width, whereas the Moretus matrices have three variants of the normal character (4, 4.5 and 5 mm). These additional sorts may have been cut at a later date.

Aleph Extended: The width of the matrix at the Plantin Moretus is 7.6 mm.



Heh: The Le Bé specimen has three variants (normal set, normal extended and extended), whereas the Plantin Moretus matrices have three variants of the normal character (4.1, 4.7 and 5.2 mm). The extended final heh on the specimen is much wider and does not appear in the Plantin Moretus matrices

Mem: The Plantin Moretus matrices have a Mem (4.6) and four final Mem's (4, 4.2, 5.1 and 7.8 mm)

Lamed: Both the specimen and the Plantin Moretus matrices have three widths: 4, 4.6 and 5.5 mm.

Ayin: The Plantin Moretus matrices have two sorts with different descenders (4.2 and 4.6).

Tav: The Plantin Moretus matrices have two sorts of the normal Tav (4.2 and 4.5) and an extended final Tav (5.1).

- The following additional sorts appear in the Plantin Moretus matrices: aleph/lamed ligature, aleph with holem, bet with dagesh, gimmel with dagesh, dalet with dagesh and two holems, heh with holem, heh extended with holem, vav with dagesh, vav with holem, zayin with dagesh, tet with dagesh, yod with dagesh, kaph with dagesh, kaph final with dagesh, kaph final with kametz, lamed with dagesh, mem with dagesh and holem, samekh with dagesh, nun with dagesh and holem, peh with dagesh, koph with dagesh, tsadde with dagesh, shin with two holems, shin with two holems and dagesh, tav extended with dagesh, and tav with dagesh and holem.
- There are 13 punctuation, vowel or cantillation signs in the Plantin Moretus matrices: a punctuation full stop, a telisha gedolah, a Patach (?), a kametz, a chirek, a shva, a tsere, a segol, a hyphen, three possible makafs and a shalsholet.

MA72 (labelled *Vrai texte hebreu/vrai texte de la facon de venise*) is amongst the most perfectly finished and justified matrices in the Plantin Moretus collection of Hebrews, and Le Bé's annotations seems clear evidence that he was responsible for justifying the matrices.⁴⁷¹ There are two notches on the back and front of the matrices, which may have been intended to hold the mould spring in place during casting. There are also small circular indents in the matrices on one side which may

⁴⁷¹ Et je en achepté une frappe de la vefve qui me presta les poinsons pour la fayre à mes despens avant que les vendre (NAF 4528 folio 8)

have been added at a later stage also to hold the mould spring in place. Some of the matrices have repetitive 'v' shaped pin marks on one side whose purpose is not clear.

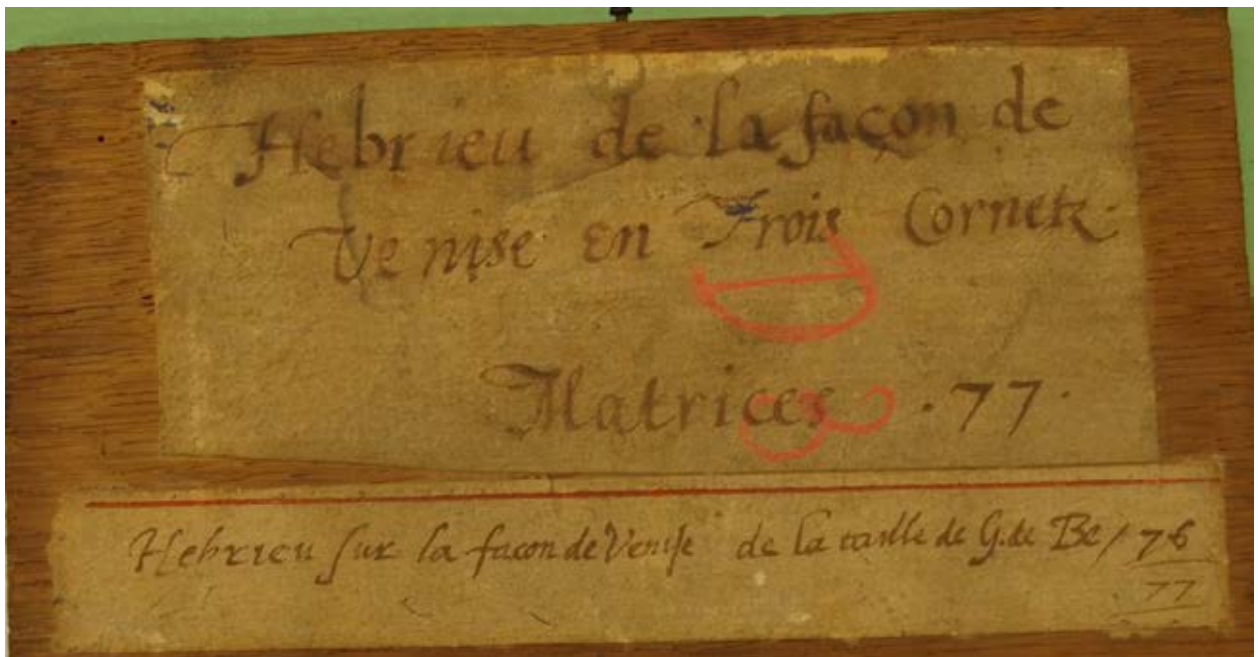

Fig. 3.16: Hb11(S) Matrices and label. Reduced approximately 77% from original width of 21 cm. (Museum Plantin-Moretus/Prentenkabinet)



Fig. 3.17: Hb11(S) Colophon from *Cantica Eruditionis*. BL (1982c36(2)). The Hebrew gives the printer's names (Guillaume Morel), date in the Hebrew calendar (the month of Cheshvan 1558) and place of printing (Paris). The date in roman numerals is one year later (1559).

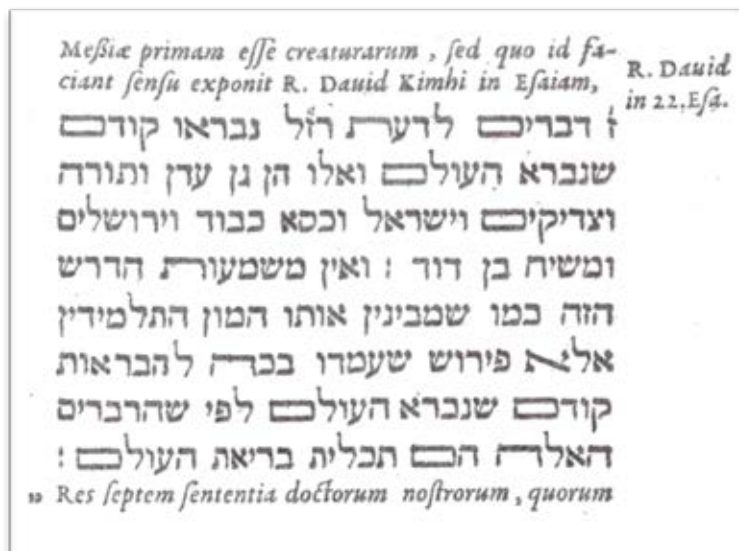

Fig. 3.18: Hb11(S) Text specimen from Gilbert Générard, *De Sancta Trinitate*, Jean Bienné, Paris 1569, from Renouard, *Répertoire des Imprimeurs parisiens*, plate B (II) 38.

The first use of this typeface in Paris can be dated precisely to the edition from which the specimen is taken from the *Cantica Eruditionis intellectus* of 1561. There are similar Square Sephardics in detail and size in the editions of Giovanni di Cavalli, but there is no evidence to establish a trail from Le Bé in Paris to printers in Venice in the second half of the sixteenth century.

Attributions for this typeface in printed editions:

- *Cantica Eruditionis intellectus*, Paris, Guillaume Morel, 1561
- *De Poeta Hebraeorum* Paris Guillaume Morel. 1563
- *De S. Trinitate*, Paris Pierre L'Huillier, 1569
- *Novum Testamentum*, Paris, Jean Bienné, 1570
- Yosé ben Halaphta, *Seder 'Olam rabba: Seder 'Olam zuta*, Basle, Ambrosius Frobenius, 1580?
- *Biblia Hebraica*, Antwerp, Plantin, 1582
- Eliezer Ashkenazi, *Ma'asei Hashem*, Venice, Di Gara, 1583?
- *He Kaine Diatheke Novum Testamentum*, Paris: Jean Benenatum, 1584
- *Linguae Hebraicae Institutiones Absolutissime*, Paris, Guillaume Le Bé II, 1609?
- *Hagadah shel Pesach*, Venice, Israel ben Daniel Zifroni, 1606
- *Linguae Hebraicae Institutiones Absolutissime*, Paris, Guillaume II Le Bé, 1609
- Philippe d'Aquin, *Dictionarium absolutissimum*, Paris, Antoine Vitré, 1629
- Johann Rittangel, ספר יצירה *id est Liber Ierzilah*, Amsterdam, Apud Johannum et Jodocum Ianssonios, 1642?
- *Biblia: 1. Hebraica: 2. Samaritana*, Paris, Antoine Vitré, 1645
- *Mare Rabbinicum Infidum*, Paris, Pierre Variquet, 1667
- *Glossarium Universale Hebraicum*, Paris, Imprimerie Royale, 1697?

Hb12 (S)

Appears on NAF 4528 folio 9

Size: Gros Double Canon; Gros Hebreu Fort Gros (MPM), In Vervliet's *Conspectus* Le Bé's Hebrew on Seven-line Pica (Hb 15) or Grosse Nompaille

Type Classification: Square Sephardic pointed and unpointed

Measurement: x-height of 15 mm

Date of creation: 1559 in Paris

Punchcutter: Guillaume I Le Bé (His tenth numbered)

First Appearance: *Grammatica Hebraea*, Plantin Antwerp, 1564?? Or *Biblia Polyglotta*, Plantin Antwerp, 1568-72

Type specimens: Plantin *Index Characterum* 1567, No. 3 (Tres Gros hebreu), Plantin Folio specimen of 1585 No. 83

Material Preserved: MA6 and ST50 at MPM

Literature: Vervliet *Conspectus*: 403/Hb 15 - Le Bé's Hebrew on seven line pica or Grosse Nompaille; *Inventaris van de stempels en matrijzen van het Museum Plantin-Moretus*, p. 109, Vervliet and Carter, *Type Specimen Facsimiles II*, pp. 2, 11

This typeface presents us with an usually rich array of comparative elements: the smoke proofs of the actual specimen, the matrices and punches held in the Plantin Moretus Museum in Antwerp and the actual printing specimens beginning with its use in the Plantin Polyglot Bible (*Biblia Regia*). The smoke proofs (*fumés* in French) are in effect working proofs and are used by the punchcutter to test the progress of the engraving. They are extremely rare for the sixteenth century. They also show that Le Bé was unable to obtain a printed proof with his name, as was his usual practice, which may be due to events related to the French Wars of Religions.

The original date in the annotation was 1562, later amended to 1559. The first War of Religion lasted from 1562 to 1563.⁴⁷² The first 'troubles' to which he refers most probably occurred during this first phrase.⁴⁷³ And it was during this time that Christophe Plantin was in Paris - January 1562 to June 1563 - having fled from Antwerp during that period, when he had fallen under suspicion for printing heretical works for the Family of Love, and its leader Hendrik Niclaes. The sale of the Garamont foundry took place sometime after Garamont's death in November 1561, a time when Plantin was likely to have been in Paris.⁴⁷⁴ This is confirmed by the second annotation on this folio: 'Venduz 1562. – Les poisons pour 5 escus à 50s. Le cuivre à 3 l. 10s. Le moule nef, 4 l.'

⁴⁷² 1562-63 - The first war started after the Edict of Toleration in January 1562. Catholic violence at Vassy in March signaled the start of first war. This ended in March 1563 with the Treaty of Amboise. See 'French Wars of Religion – a quick timeline' (<<http://jimmcneill.wordpress.com/2011/04/09/french-wars-of-religion-a-quick-timeline/>> [Accessed 16 July 2011], 'The Wars of Religion' (<<http://www.lepg.org/wars.htm>> [Accessed 16 July 2011])

⁴⁷³ James B. Wood, 'The Impact of the Wars of Religion: A View of France in 1581', *The Sixteenth Century Journal*, Vol. 15, (1984), p. 167

⁴⁷⁴ Clair, *Christopher Plantin*, pp. 37-38, 249. See also Parker, Melis, and Vervliet, *Typographica Plantiniana II*, p. 15

A further clue to the date is the first note of this typeface in the Plantin inventories: 1563, which lists MA6 as 'gros Hebrieu fort gros de Guillaume le Be (sic) contenant Le Moule a fondre laditte lectre' and ST50 as 'Poinsons d'ung tres gros hebrieu Guillaume le Be (sic) 27 poinsons et 8 points'. Le Bé also sold punches of the Garamont Augustine and Bible Romans, which Vervliet notes 'were among the most important he owned. Le Bé must have been in financial difficulties to sell these sets, as they were sources of a steady future income.'⁴⁷⁵ He does not give any further details, but one can imagine that his business must have suffered due to the effects of the first War of Religion. A study of the impact of the wars of religion on individual dioceses in France noted the 'widespread impact' of the wars and notes that 'few areas remained untouched, almost all incurred serious, and many extremely serious costs and damages'. This study concludes that this was a 'cultural disaster of the highest magnitude'.⁴⁷⁶

Yet what would have prompted Le Bé to cut such a large Hebrew and for what potential audience? At least two large display Hebrews of about 15 mm height appear in some Venetian Hebrew editions during the 1540s – for example in the editions printed by Meir di Parenzo and Alvise Bragadin – and in the early seventeenth century in the *Hagadah* printed by Israel ben Daniel Zifroni and Gershon Prinz (or Parenzo).⁴⁷⁷ Although Le Bé does not provide examples of these in either of the two Paris documents, there can be little doubt that he would have been aware of them. It also has to be said that they are very crude in detail and execution, which may have provided the motive for Le Bé to produce his own version. The examples below from the Bragadin *Mishneh Torah* of 1550 and the 1609 Venice *Hagadah* give an idea of the quality of these letters. Although they are Sephardic in style, they show a misunderstanding of the way the terminal strokes are constructed in Hebrew. Perhaps Le Bé's idea was to sell strikes of this typeface to his contacts in Venice, but this plan did not materialise due to the troubles in France and the slowdown in Hebrew printing in Venice following the papal bull of 1553 which led to the burning of Hebrew books in Rome and Venice.⁴⁷⁸



Fig. 3.19: Examples of the 15 mm display Hebrew from the Bragadin *Mishneh Torah*, Venice, 1550 (BL 1918e2) (Reduced)

⁴⁷⁵ Parker, Melis, and Vervliet, *Typographica Plantiniana II*, pp. 15-17

⁴⁷⁶ Wood, *The Impact of the Wars of Religion: A View of France in 1581*, p. 167

⁴⁷⁷ See Bezalel Narkiss and Leone Modena, *Seder Hagadah shel Pesach, Venetsyah 369 = The Passover Haggadah, Venice 1609* (Jerusalem: Makor, 1974)

⁴⁷⁸ Amram, *The makers of Hebrew books in Italy*, pp. 266-277. See also David Kaufmann, 'Die Verbrennung der Talmudischen Litteratur in der Republik Venedig', *The Jewish Quarterly Review*, 13 (1901). See page 93105 of this thesis for further discussion.



Fig. 3.20: Example of 16 mm display type from 1606 Venice *Hagadah*. (Reduced)

The Plantin inventories record Hb12 (S) on five different occasions: 1563, 1566, 1572, 1590 (Leiden) and 1652. The first was in 1563. The second in 1566 and lists a ‘Gros hebrieu extraordinaire poinsons matrices et mousle iustifiees (ST50 and MA6) and the third in 1572: Poinsons du plus gros Hebrieu de G. le be (sic) (ST 50), the fourth in 1590 Leiden: Hebraiques de diverse sortes and finally the fifth in 1652: 33 Allergrootste Hebreusche (MA6). The box containing the punches (ST50) has 33 punches in all, 27 letters and 6 accents or punctuation. These punches range in height from roughly 50 to 70 mm for the letters, and 40 to 52 mm for the accents. The punches do not have any clear identification marks on them, as might have been expected from the list of punches in the 1730 document, but they do have distinct separate horizontal lines on one side of some of the punches.⁴⁷⁹

What is noticeable is that there appear to be the signs of dagesh points in the counters of the bet, chet, tet, kapf, mem, mem sofit, samekh, ayin, peh, peh sofit, koph, shin, and tav, and this could lead to the conclusion that the matrices were first struck *with* the dagesh point, then the points filed down and a new set of matrices struck *without* the dagesh points. Yet when they were re-examined together with Fred Smeijers, it was evident that the indentation were not dagesh points, but *rather* signs of the initial drilling used to produce the counter.⁴⁸⁰ If these had been dagesh points subsequently removed from the punch with an engraving tool, then one would *not* see a round indentation, but more of a smoother surface in the counter. Fred Smeijers also did not think that counterpunches would have been used to produce these Hebrews. Thus a feasible hypothesis for a working method which Le Bé would have used would be first to define the contours of the character on the face of the punch, then produce the outer contours of the character using files gravers (burins), and finally drill into the centre of the counter to create the initial ‘hole’, followed by the use of scrapers or gravers to create the final shape.

⁴⁷⁹ Fournier and Morison, *L’Inventaire de la Fonderie Le Bé* The inventory lists distinctive graphic symbols against each of the founts mentioned and it was this researcher’s theory that these symbols might be found on the actual remaining Le Bé punches. Such was not the case as no such symbols were visible and one hypothesis is that these symbols could have been added at a later date for identification and/or sorting.

⁴⁸⁰ This examination took place during a visit to the MPM in April 2013.

Fred Smeijers has proposed three possible procedures for inserting the dagesh points on the matrices of Hebrew typefaces. They are as follows:

1. The punch cutter cuts a punch of the Hebrew character complete together *with* accents, then using this punch he produces a number of strikes. He then softens or anneals the punch, cuts off the tip of the accents, hardens the punch once again and produces additional strikes *without* the accents.
2. The punch cutter cuts the punch *without* accents, produces some strikes and then adds the relevant accents to the strikes (as a secondary operation). This could have been done through the use of a small drill which was drilled directly into the strike.
3. The same as procedure 2, but *instead of using a drill the punch cutter uses a small punch* to strike the accent in the matrix.⁴⁸¹

In MA6 the dagesh points on the matrices appear to have been struck separately. It should also be noted that the smoke proofs on the specimen show certain characters *with* a dagesh point: the chet, kapf, mem, and nun. This could indicate that Le Bé added the dagesh points separately as he was working on the engraving of these characters.

The matrices in MA6 are well justified on the side bearings, but not consistently even in height as can be seen from the image below. It does appear that a key factor in producing consistently aligned type was the distance from the top of the matrix to the head of the Hebrew character, as the matrices were butted to the top of the mould when casting. The matrices for MA40 are almost identical in depth and were probably also struck by Le Bé, which confirm this point and the importance of this key distance.⁴⁸²

⁴⁸¹ Email correspondence with Professor Hendrik Vervliet and Fred Smeijers, June 2011.

⁴⁸² I am indebted to Guy Hutsebaut of the Museum Plantin Moretus for clarification on these points.



Fig. 3.21: MA6 Reduced 50 per cent (Museum Plantin-Moretus/Prentenkabinet)



Fig. 3.22: ST50 Reduced 50 per cent (Museum Plantin-Moretus/Prentenkabinet)

This typeface has all the characteristics of a mature Le Bé Hebrew typeface. The lamed has a distinctive ‘flag’ termination to the ascender, the final kapf, nun, tsadde and peh all have similar angled descenders to the right, and both the bet and kapf have longer baseline strokes protruding beyond the upper horizontal strokes. There are differences between the smoke proofs and the character set in Antwerp, such as the two slightly differing forms of the Lamed, and the letter Chet with a dagesh. This latter case is not possibility in Biblical Hebrew, as the characters which usually take

the Dagesh Lene (*Kal* in Hebrew) are the bet, gimmel, dalet, kaph, peh, and tav, known collectively as the ‘Begadkephat letters’. The Dagesh Forte (*Chazak* in Hebrew) can appear in any Hebrew consonant *except* on a guttural letter.⁴⁸³ Thus the inclusion of the Chet with a dagesh on the smoke proofs may be a mistake on Le Bé’s part, but what appears to be a circular indent in the counter of the bet, may also be the impression of a pump drill, used to begin the cutting out of the counter of the punch. The first two images show the matrix for the aleph as it would have struck with the punch for the same character. The matrix for the bet and dalet show clearly how the dagesh was struck or drilled as a secondary operation.

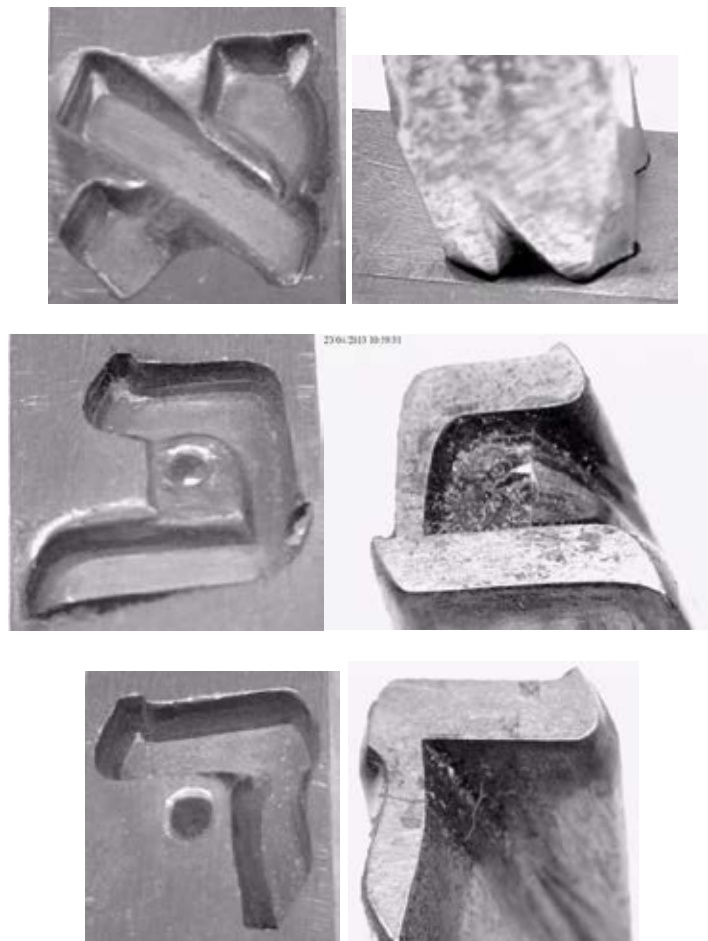

Fig. 3.23: Microscopically enlarged photos of MA6 and ST50, showing the aleph, bet and dalet. Enlarged 2x (Museum Plantin-Moretus/Prentenkabinet)

⁴⁸³ Martin, *Davidson's Introductory Hebrew Grammar*, pp. 20-21

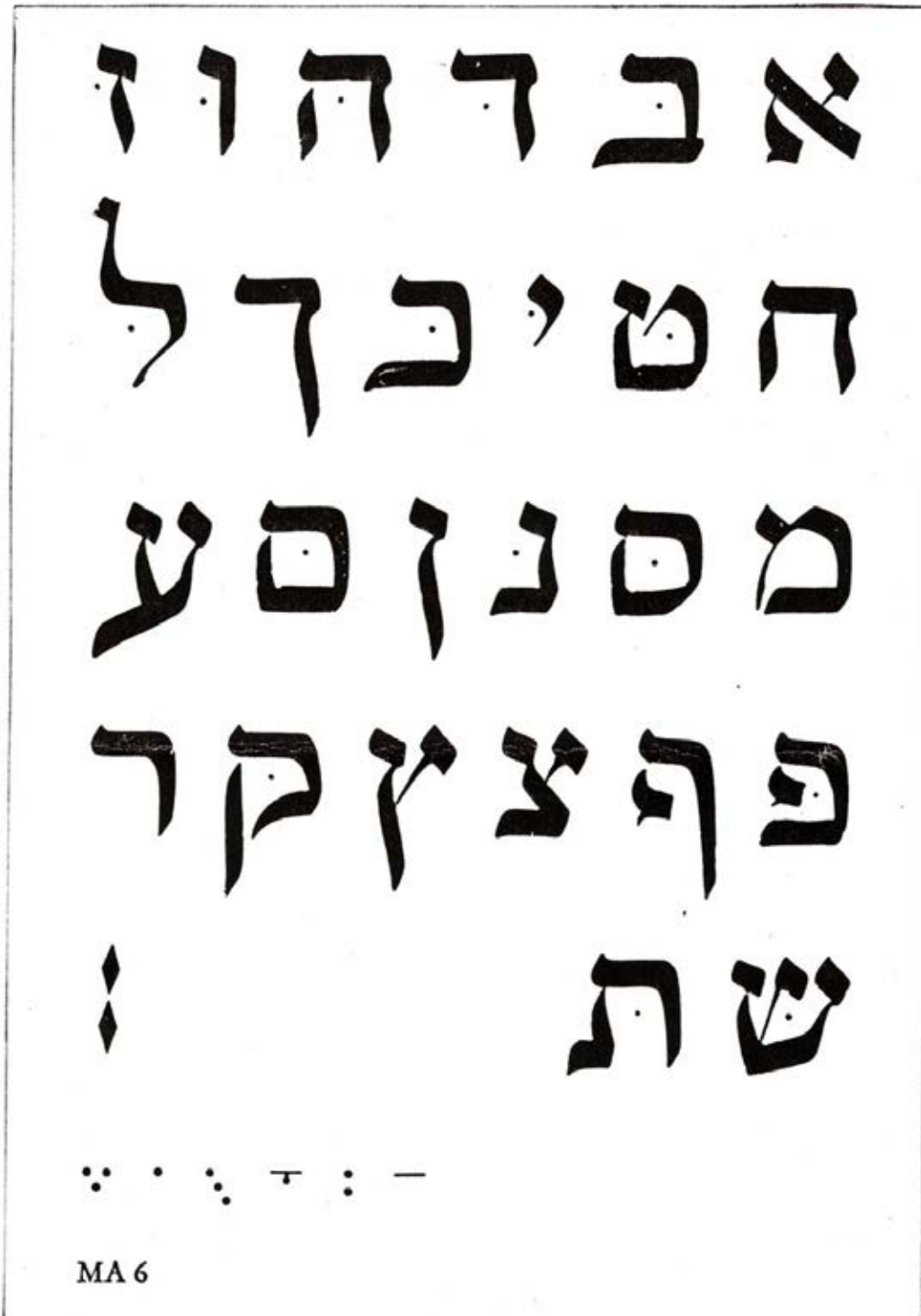

Fig. 3.24: Alphabet from the matrices for MA6, Actual Size (Museum Plantin-Moretus/Prentenkabinet)

Le Bé calls this typeface a *Gros Duple Canon*, and this size most closely equates to Gros Double Canon in Fertel, the largest of the sizes in his list.⁴⁸⁴ Vervliet identifies it as a Seven line pica or Grosse Nompaille, which is equivalent to 82pt Anglo American or 77pt Didot. The x-height of the final mem is 15 mm and this appears to be slightly over 60pt Anglo-American, thus once again we have the problem of assigning a comparative numeral or indeed equivalent name to Le Bé's types. It is interesting to note the various names assigned to this typeface in the Plantin inventories, which emphasize the large size (*très gros*, *extraordinaire*, and *Allergrootste*).

Le Bé also notes that he sold this material *à bon marché*: Les poinçons pour 5 escus à 50 s. Le cuive (= copper or matrices) à 3 l. 10s. Le moule nef (= neuf), 4 l. French currency at the period was divided into 'Livres, Sous and Deniers although the smallest coin was the copper gros (4 denier) and also had the écu worth 3 livres'. The same source also notes that 'a French livre was worth approximately the same as a guilder in the early 1630s but the actual amount decreased steadily over time'.⁴⁸⁵ This then works out at roughly 15 livres for the punches, the matrices at 3.5 livres and the mould (as new) at 3 livres. If this was indeed cheap, one has to compare prices paid by Plantin during the same period for punches and matrices. Voet describes the purchase of 20 sets of punches and 12 sets of matrices in 1581 for 1,400 fl (florins), which works out at about 44 florins per set. If the florin and livre (tournois) were roughly equivalent, then these prices were indeed *à bon marché*.⁴⁸⁶

The first use of this typeface was probably in the *Biblia Hebraica* of 1564, yet it was most certainly used in the Plantin *Biblia Regia* of 1568-72 on the Hebrew title page.



Fig. 3.25: Specimen from the *Biblia Hebraica*, Antwerp, Plantin, 1580, Actual Size (BL 1942g14)

⁴⁸⁴ Fertel, *La science pratique de l'imprimerie*, p. 2

⁴⁸⁵ Francis Turner, 'Money and exchange rates in 1632' (2010) <1632.org/1632Slush/1632money.rtf> 17 July 2011]. See also 'Money and Prices' (<<http://www.maisonstclair.org/resources/pricelist/pricelist.html>> [Accessed 6 November 2013])

⁴⁸⁶ Voet, *The Golden Compasses*, pp. 74, 440-453 (Volume 442)

Hb13 (S)

Appears on NAF 4528 folio 10 and 13 and Rés X 1665, folio 5v and 6

Size: Texte; Vervliet *Conspectus* Two line Pica Hebrew [Hb 3.8] or Palestine

Type Classification: Square Sephardic pointed

Measurements: x-height of 3.6 mm on 4528 folio 10 and Rés X 1665, folio 6; x-height of 3.7 mm on 4528 folio 13 and Rés X 1665, folio 5v; Interlinear spacing – 8 mm on NAF 4528 f.10 and 9 mm on NAF 4528 f.13

Date of creation: 1565-1566 in Paris

Punchcutter: Guillaume I Le Bé (His eleventh numbered)

Type Specimens: Plantin Folio Specimen c. 1585 no. 86; MA40 in PM, Le Bé specimens in the MPM archives (Arc. 153), Moretus specimen: No. 24 of 1599; *Spécimens des Types Français et Etrangers de l'Imprimerie Nationale*. 1855 (Hébreu No. 2)

Materials preserved: MA 40 at MPM, In Plantin's Folio specimen: of 1585 No. 24

Literature: Vervliet *Conspectus* 397/Hb 3.8, Fuks and Fuks-Mansfeld, p. 20 (Raph. Sq. 3), Le Bé *Inventaire après décès* c. 1617 (Hebreu parangon) – probable attribution

First occurrence: *Biblia Regia*, Antwerp, 1569-72

This typeface appears in four separate instances in the two Paris documents, and it is at first a temptation to list them as two separate typefaces. The interlinear spacing differs by one millimetre between the two specimens, and the appearing size of the final mem by .1 mm – 3.6 as against 3.7 mm. Furthermore, neither specimen contains a complete enough range of recognition characters to be able to make a complete comparison. The only definite claim by Le Bé for Hb13 (S) is in his annotation on NAF 4528 f. 10. None of the other three specimens make specific mention of this typeface.

These discrepancies can perhaps be explained by ink squash which would make the second set of specimens appear larger and being cast on a larger body.⁴⁸⁷ In terms of style, the two sets of specimens are identical. Thus although Vervliet does not list both sets, he does give two specimens in his *Conspectus* and this thesis will follow his lead and consider all four instances to be the same typeface.⁴⁸⁸

The text of this specimen is from Psalms 65: 7-10, whereas the text of the specimen on NAF 4528 folio 13 is from Zechariah 14:6-7. The text from Psalms contains one typographical error: an initial Tsadde (צ) is used in place of the final Tsadde (ץ) in the word 'HaAretz' (הארץ) in line 4, which indicates either that the relevant character was missing from the case, or that the compositor was not aware of the rules of Hebrew orthography.

⁴⁸⁷ See Parker, Melis, and Vervliet, *Typographica Plantiniana II*, p. 43. Parker *et al* mention that Le Bé 'knew this as *Parangon* and which Plantin cast on *Double Nompaille* and set to *Double Mediane* when he used the points'. And indeed the specimen in the Folio Specimen of c. 1585 has the heading *Double Mediane*.

⁴⁸⁸ Vervliet, *French Renaissance Printing Types: A Conspectus*, p. 415

Le Bé mentions that he engraved it 'grossi de la Bible in 4^{to} de Robert Estienne' (enlarged from the Quarto Bible of Robert Estienne) and this can only mean the 28 sections printed by Robert Estienne during the period 1538 to 1544.⁴⁸⁹ This is of particular importance to Le Bé, as it covers the greater part of his apprenticeship with Estienne.⁴⁹⁰ Yet what is one to make of term *grossi*? It could imply that he used a model one of the Estienne Hebrew typefaces (most likely cut by Jean Arnoul dit Le Picard) or that that he used the nearest equivalent size and made a revised version.⁴⁹¹ Hb13 (S) has in fact an x-height of 3.6 mm. Whatever the meaning, the relationship between them was a close one, and Vervliet assumes that 'he (Le Picard) apparently acted as an instructor to Guillaume I Le Bé'.⁴⁹² There is little doubt that Le Bé was a gifted student and that his Hebrew types follow the model set by Arnoul, yet are clearly distinct in detail and execution.

The full assembled alphabet shows once again the hand of Le Bé, with angled descenders to final nun, kapf, tsadde, and peh, the distinctive aleph/lamed ligature and characteristic extended mem, tav and heh. The flags on the left and right vertical strokes of the shin point right, whereas the flag on the middle stroke points to the right.

This is also the first Le Bé Hebrew typeface which shows a range of cantillation marks, as well as vowel points, in the specimen. The only other specimen in NAF 4528 to show these marks is Hb19 (S) on folio 12v. None of the earlier Venetian Le Bé specimens show these marks, whereas Le Bé did cut both dagesh and vowel points in HB4 (S) in his second numbered type for Giustiniani. It cannot be argued that Le Bé was unaware of them, as the Estienne Hebrew Bibles which were produced during his apprenticeship do show them. Nevertheless producing a full Hebrew fount with all its components – some 70 punches for the basic characters, characters with dagesh points, the vowel points and the cantillation marks – would have been a lengthy process. Thus Le Bé would have only cut these if he was requested to do so.

The matrices for this typeface are to be found in the Plantin Moretus Museum (MA 40) and comprise a total of 57 characters, 26 basic, four punctuation and 27 with dagesh points or ligatures. All the matrices have small indents at base, usually on all four sides and the reverse side of each character has a notch for the mould spring and a more recent circular indent positioned above. The vowels and cantillation marks for the pointed setting are most probably from MA83c (Double Mediane vowels and

⁴⁸⁹ McLeod, 'ALTVM SAPERE', in *La Bible imprimée dans l'Europe moderne (XVe-XVIIIe siècle)*, ed. by Schwarzbach (Paris: Bibliothèque nationale de France, 1999), pp. 86-88

⁴⁹⁰ Le Bé, *The Le Bé memorandum*, p. 21

⁴⁹¹ From the verb *grossoyer* meaning 'write faire or in great and faire letters'. See Cotgrave, *A Dictionarie of the French and English tongues*

⁴⁹² Vervliet, *French Renaissance Printing Types: A Conspectus*, pp. 41-42

intonations), which the *Inventaris* notes ‘are justified in exactly the same style as MA40’.⁴⁹³



Fig. 3.26: MA 40 made from ST50, Actual size (Museum Plantin-Moretus/Prentenkabinet)

Microscopic examination of three of the matrices – the dalet, the heh and the shin – show the tell-tale signs of the manual insertion of the dagesh points in the centre and the two sin/shin points above. They appear to have been struck initially with some kind of punch given the uniform flat impression surface, but finished by hand with either the use of a hand file or a pump drill.⁴⁹⁴

⁴⁹³ Museum Plantin-Moretus., *Inventaris van de stempels en matrijzen van het Museum Plantin-Moretus. Inventory of the Plantin-Moretus Museum punches and matrices. Eng.* (Antwerpen: Museum Plantin-Moretus 1960), p. 112

⁴⁹⁴ See diagram on page 182 of this thesis.

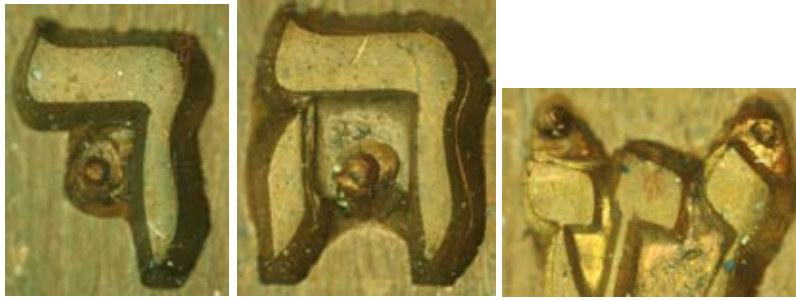

Fig. 3.27: Microscopically enlarged characters from MA40 (Photos By permission of Fred Smeijers and the Museum Plantin-Moretus/Prentenkabinet)

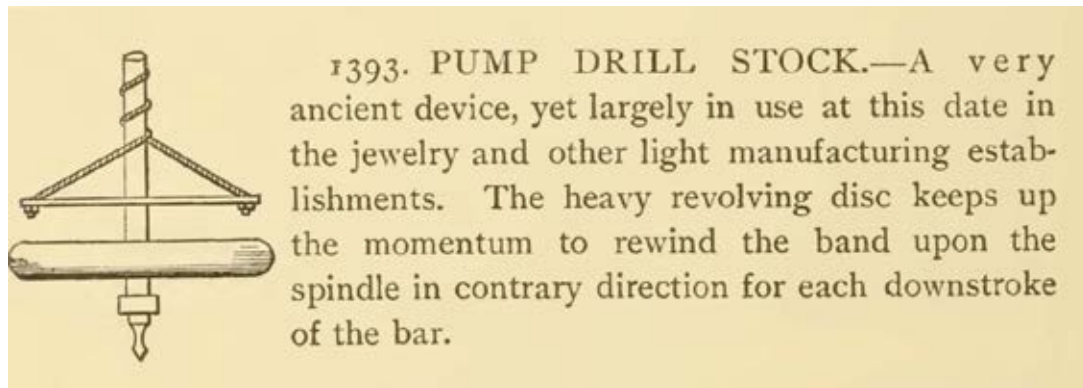

Fig. 3.28: A hand pump drill and its operation from Hiscox, *Mechanical Movements, Powers, Devices and Appliances*, 1914

In the Plantin Moretus archives there is a page showing a casting register or bill dated 1st August 1568 for these two typefaces which almost exactly matches the number of sorts: 56 characters with normal, extended and or dagesh points; 20 vowels or cantillation marks cast to 'Heel punten' (whole points); 23 vowels or cantillation marks cast to 'Halve punten' (Half points), and 14 Arabic numerals. There are also lists of quadrats or spacing. The total number of sorts cast is 77,895 at a value of 39 Florins 2 stuyvers.⁴⁹⁵ This list gives some idea of how Hebrew might have been set in the sixteenth century and perhaps even later. The 'Heel punten' are most likely to be accents and cantillation marks cast to the *full* set width of the main character, whereas the 'Halve punten' would be cast on a smaller body as a modular proportion of the main character to allow both characters and accents to fit tightly in the forme. The specimen from the *Biblia Regia* in Fig. 3.39 shows examples of both situations. This solution would also be necessary for situations where the vowel is not centred on the set of the letter and thus needs to be cast on a smaller body. The same sheet also contains the spaces (Dick spatien = thick spaces and Dunne spatien = thin spaces) and the same spaces for the halve punten. In this case the difference between the numbers cast is not so extreme - 3970 as against 4470 for the thick spaces, and 2312 as against 1870 for the thin spaces.⁴⁹⁶

⁴⁹⁵ Plantin Moretus Archives, Archive 513, p. 39. The heading for this sheet names this as a 'nompaille'.

⁴⁹⁶ For a detailed discussion of typesetting accents using computer software see Yannis Haralambous, 'Typesetting the Holy Bible in Hebrew, with TEX' (1994) <<https://www.tug.org/TUGboat/tb15-3/tb44haralambous-hebrew.pdf>> [Accessed 6 November 2013]. The problems of placement for

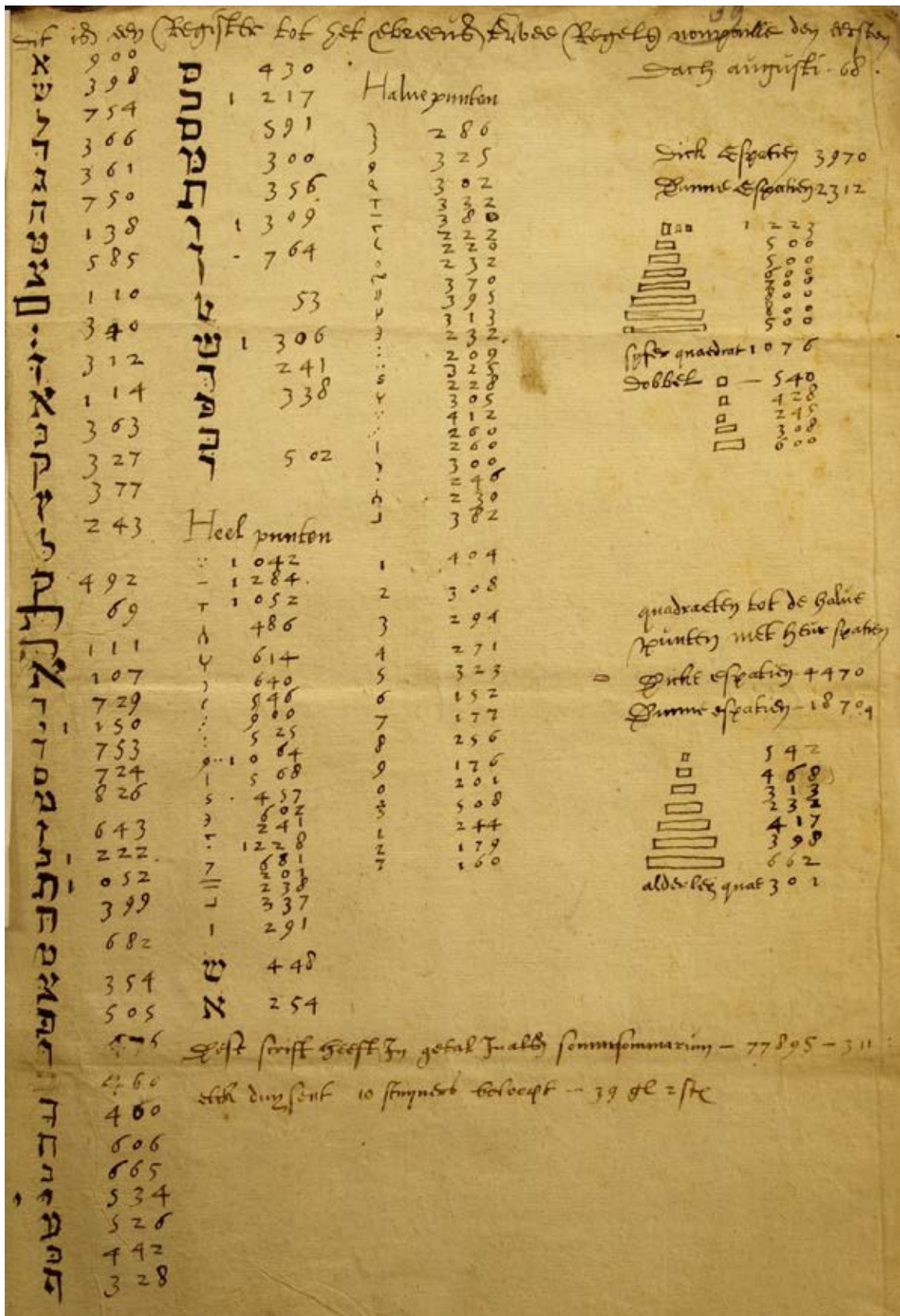

Fig. 3.29: Casting bill for MA40 and MA83c from the Archief 153, f. 39 Reduced 70 per cent (Museum Plantin-Moretus/Prentenkabinet)

'floating accents' are similar in hot metal setting. For a discussion of setting the vowels in the Monotype scheme, see J.F. Coakley, *The Hebrew Types of the Jericho Press* (Ely, 2010), pp. 2-4

The actual numbers of the sorts cast confirms this theory. For example, under the category 'Heel puncten' the quantities are listed for the following accents: Segol = 1042, patach = 1248 and kametz = 1052. Under the heading 'Halve puncten' the quantities are Segol = 412, patach = 380 and kametz = 332. Thus the greater requirement was for accents and cantillation marks for the full set width and presumably the type case would have reflected this. Voet notes that 'Hebrew alphabets, without the difference between capitals and lower case, all had single cases, whenever specified'.⁴⁹⁷ Yet Lefèvre's nineteenth-century description of Hebrew types cases shows two cases, a *haut de casse* and a *bas de casse*.⁴⁹⁸ The 'haut de casse' contains all the basic characters with dagesh points and the cantillation marks in the upper row; the *bas de casse* contains all the unpointed characters, extended characters, punctuation, vowel points and spacing. There do not appear to be additional compartments marked for different widths of accents.

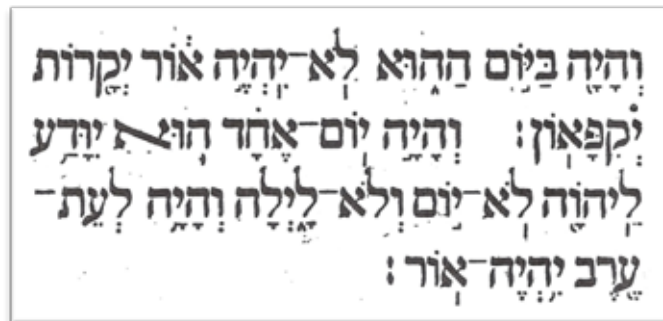

Fig. 3.30: Hb13 (S): Specimen from NAF 4528 f. 13

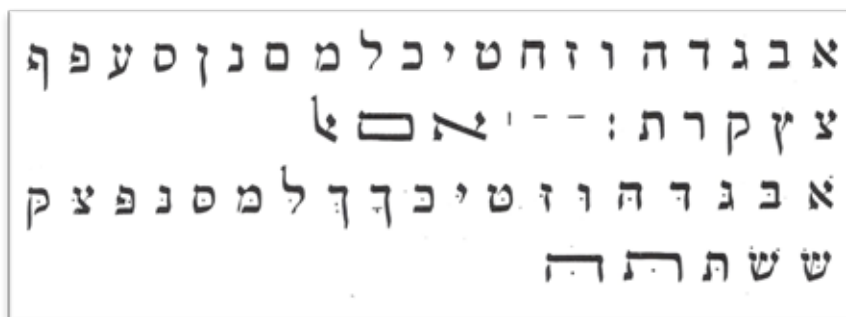

Fig. 3.31: Hb13 (S): Full assembled alphabet from the MA40 matrices (Museum Plantin-Moretus/Prentenkabinet)

⁴⁹⁷ Voet, *The Golden Compasses*, p. 144

⁴⁹⁸ Pierre Théotiste Lefèvre, *Guide Pratique du Compositeur d'Imprimerie* (Paris: Librairie de Firmin Didot Frères, 1855), p. 308



Fig. 3.32: Hb13 (S): Assembled partial alphabet from the MA40 matrices (Museum Plantin-Moretus/Prentenkabinet)

MODÈLE DE CASSE HÉBRAÏQUE.

HAUT DE CASSE.

א	ב	ג	ד	ה	ו	ז	ח	ט	י	כ	ל	מ	נ
ס	פ	צ	ק	ר	ש	ת	א	ב	ג	ד	ה	ו	ז
ח	ט	י	כ	ל	מ	נ	ס	פ	צ	ק	ר	ש	ת
א	ב	ג	ד	ה	ו	ז	ח	ט	י	כ	ל	מ	נ
ס	פ	צ	ק	ר	ש	ת	א	ב	ג	ד	ה	ו	ז
ח	ט	י	כ	ל	מ	נ	ס	פ	צ	ק	ר	ש	ת
א	ב	ג	ד	ה	ו	ז	ח	ט	י	כ	ל	מ	נ
ס	פ	צ	ק	ר	ש	ת	א	ב	ג	ד	ה	ו	ז

BAS DE CASSE.

..	·	-	:	:		א	ב	ג	ד	ה	ו	ז	ח
Cadrats de trois		ד	ה	ו		א	ב	ג	ד	ה	ו	ז	ח
Esp. à point		ל	מ	נ		א	ב	ג	ד	ה	ו	ז	ח
Esp. à p. 1/2						א	ב	ג	ד	ה	ו	ז	ח
Cadrats de trois	ד	ת	ו	Espaces.		א	ב	ג	ד	ה	ו	ז	ח

Fig. 3.33: Hebrew type case layouts from Lefevre, *Guide Pratique du Compositeur d'Imprimerie*, Paris 1855

The composition or setting of pointed Hebrew requires a degree of complexity not present in the setting of most Roman alphabets. Fournier describes the alignment of the main characters and the points and the size on which they are cast. He also describes the technique of casting the main character and accent on a mould which had 'a body equal to that of the letter added to that of the points, so that if one were pica and the other nonpareil, their second mould was great primer, which is the size of nonpareil added to a pica'.⁴⁹⁹ He does not describe the actual process of composition and here the most complete description is from *Lefèvre's Guide Pratique du Compositeur d'Imprimerie* of 1858. There is not a similar discussion from any earlier date known to this writer. Firstly Lefèvre notes the differences between Hebrew composition in Germany, where it is set generally from right to left with the nick facing down, whereas in France it is set from left to right with the nick facing up, as with Arab composition. In the first step, the main characters with dagesh points are composed in the composing stick *without* any accents or cantillation marks. The second step is to set the upper vowel points and cantillation marks (Lefèvre calls them the *punctuation tonique*) *below* the main line of text in the composing stick. This setting is then placed in a type galley.⁵⁰⁰ In the third step the main line of text is then reinserted in the composing stick and the lower cantillation marks and vowel points are added. Lefèvre notes that these are generally positioned 'au milieu de cachune des lettres qui en portent', with the exception of the letters dalet, vav, zayin, yod, lamed and final kapf, where they are placed 'exactement sous la pointe de leur trait vertical'. Finally in the fourth step these two lines are combined together on the galley with the upper line of cantillation marks in the correct order of appearance. (Step 4). Note that the line of cantillation marks in this example has been transferred *above* the x-height in the final step.⁵⁰¹



Fig. 3.34: Pointed Hebrew composition from Lefèvre: Step 1



Fig. 3.35: Pointed Hebrew composition from Lefèvre: Step 2

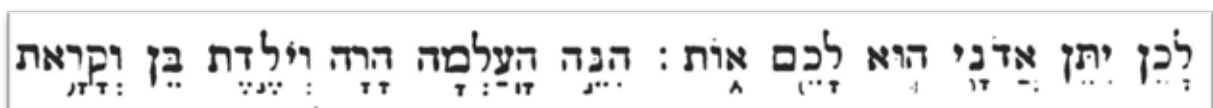

Fig. 3.36: Pointed Hebrew composition from Lefèvre: Step 3

⁴⁹⁹ Fournier and Carter, *Fournier on Typefounding*, p. 152

⁵⁰⁰In French *une galée or gallée*. A galley is a open-ended tray of wood or metal with sides lower than type height whose purpose is to 'receive the matter as it is composed and to afford a level on which to make up the pages'. See Savage, *A Dictionary of the Art of Printing*, pp. 248-249

⁵⁰¹ Lefèvre, *Guide Pratique du Compositeur d'Imprimerie*, p. 251

לִכְן יִתֵּן אֲדֹנָי הוּא לָכֶם אוֹת : הִנֵּה הָעֵלְמָה הָיָה וַיִּלְדֹת בֵּן וַקְרָאת

Fig. 3.37: Pointed Hebrew composition from Lefèvre: Step 4

This laborious method meant that only line at a time could be set and would require the use of some kind of setting rule to transfer the line of type to the type galley and back again. The positioning of these ‘accents’, whether centred or set to the left or right of the middle line, requires adequate spacing, which is what is evident on the 1568 casting register. As the Lefèvre text is from 1855, it may well be that composition practices for Biblical Hebrew in the sixteenth century were different and possibly involved the composition of all three elements at one go in the composing stick. The Lefèvre procedures are cumbersome and prone to human error, such as accidental dropping of the set line. It is also likely that the word spacing would be to full body height, thus requiring composition of all the elements of the line – main characters and points above and below – in one operation.⁵⁰²

Moxon describes the use of what he calls a ‘composing rule’, which he says is ‘very commodious to work with, because the letter slides easier and smoother down the Back of the Stick, than it will upon a Line of letters’, but he makes no mention of any special techniques for setting Hebrew. Fertel mentions the use of ‘une réglette’⁵⁰³ to transfer a line of type into the galley, so there is evidence that setting rules were known and used at least by the late seventeenth century in England and in France.⁵⁰⁴

This complexity is clear if one examines an actual page of setting, such as the first page of Genesis from the Plantin Polyglot, where Le Bé’s Hb13 (S) is used. The examples below illustrate the positioning of the vowel points and cantillation marks when single, combined, or above and below the main characters. In the case of the lamed, the ayin and the koph this also involves kerned characters. See the table on page 51 for the position of vowels and cantillation marks above or below the main characters.

⁵⁰² I am grateful to Scott-Martin Kosofsky for his comments on this specific point and on the hand composition of pointed Hebrew in general.

⁵⁰³ Terme d’Imprimerie. Petite règle de bois qui sert aux Compositeurs à tirer leurs lignes du composeur, & à les placer sur la galée. (*Dictionnaire de l’Académie française*, 4th Edition, 1762)

⁵⁰⁴ Moxon, Carter, and Davis, *Mechanick Exercises*, pp. 205-207 and Fertel, *La science pratique de l’imprimerie*, pp. 45-46



Fig. 3.38: Pointed Hebrew composition examples assembled from the Plantin Polyglot Bible (BL 6.h.4-11.) Enlarged 280 per cent

This same page also provides an example of the body size for both the main characters, the vowels and the cantillation marks. An analysis shows that the x-height is roughly 40 per cent of the body size, and the vowels and cantillations marks make up about 25 per cent. If one takes the letter mem as the ‘squarest’ character in the typeface, then the measure of the line works out at 35 ems of the character. This is no doubt the way that compositors would have worked, first setting a line of em quads in the composing stick to set the measure, whether they were adjustable or fixed measures.⁵⁰⁵ It must be assumed from the visual evidence that the ascender of the lamed, and the descenders of such letters as final peh, ayin, and final tsadde would have been kerned to allow closer fitting of the vowels and cantillation points.⁵⁰⁶

⁵⁰⁵ Plate II of the Imprimerie/Relieure section of the Diderot d’Alembert Encyclopédie shows both types, and Voet mentions that there were ‘only twelve for the period 1564 to 1566’ in the Officina Plantiniana/ See Voet, *The Golden Compasses*, p. 143 (Vol 142). He does not mention what type they were, yet most of the early ones seem to have been made of wood. See Martin K. Speckter, *Disquisition of the Composing Stick* (New York: The Typophiles Inc., 1971), pp. 25-44

⁵⁰⁶ This point was confirmed by Madame Nelly Gable and her colleagues at the Cabinet des Poinçons in Ivry, from their experience in setting ‘exotic’ types.



Fig. 3.39: Hb13 (S) Diagram of Body size, x-height and line spacing from the Plantin Polyglot Bible. Actual size (BL 6.h.4-11.)

The first use of this typeface according to Vervliet is in the Plantin edition of Sancte Pagnino's *Epitome thesauri linguae sanctae* which is dated 1570. The use in the *Biblia Regia (Polyglot)* may be earlier, as this was printed in the period 1568 to 1573.⁵⁰⁷ The following example of this typeface is from the first volume, in the first page of Genesis.

⁵⁰⁷ Voet and Voet-Grisolle, *The Plantin Press, 1555-1589: a bibliography of the works printed and published by Christopher Plantin at Antwerp and Leiden*, pp. 1740-1742 (Volume IV). This is number 1863 in Voet's listing.

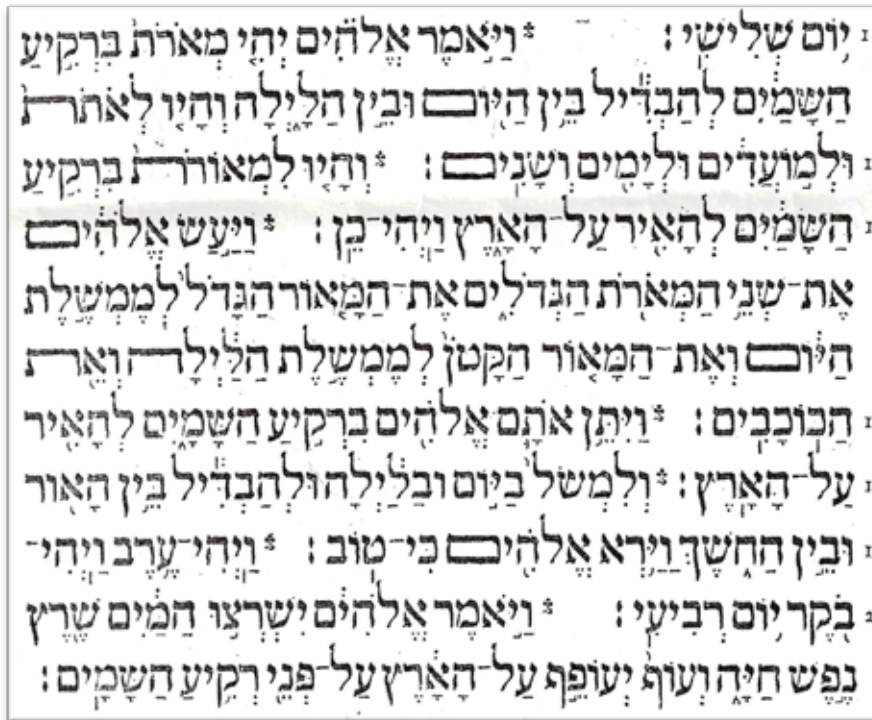

Fig. 3.40: Hb13 (S) Example from the *Biblia Regia*, Antwerp, 1568-73, (BL 6.h.4-11.)

An examination of Hebrew printed texts shows a fairly wide distribution of this typeface, one trail of which has been well documented for the Northern Netherlands. Eight Hebrews are known to have been brought to Leiden in 1583 and were used by Plantin's son-in-law Franciscus Raphelengius when he took over the business in 1585. These types, including this typeface, were 'used in many towns in the Dutch Republic for almost two centuries' and were employed by Thomas Erpenius (Professor of Arabic at Leiden), the printer Johannes Le Maire and the Leiden Elzevirs.⁵⁰⁸ The attributions in French editions can perhaps be explained by the matrices and punches listed in the 1730 inventory, where there is a hébreu Parangon (with 61 matrices) and a set of 52 punches (hébreu Parangon mon pere).⁵⁰⁹

A specimen of what appears to be an identical unpointed version of Hb13 (S) was found in an 1855 specimen of types printed by the Imprimerie Impériale. What is not clear is whether this is a survival or possibly a later recutting by the early nineteenth-century punchcutter Jacquemin.⁵¹⁰ There are eight sets of Hebrew punches and

⁵⁰⁸ Fuks and Fuks-Mansfeld, *Hebrew typography in the Northern Netherlands*, pp. 11-21

⁵⁰⁹ Archives Nationales, Paris. ET/LXV/229. See also Fournier and Morison, *L'Inventaire de la Fonderie Le Bé*

⁵¹⁰ Imprimerie Royale, *Spécimens des types français et étrangers de l'Imprimerie Impériale, Mai 1855* (Paris: Imprimerie Imperiale, 1855), p. Hebrew No. 2. See also E. C. Bigmore and C. W. H. Wyman, *A bibliography of printing: with notes and illustrations* (New Castle, Del. ; London: Oak Knoll & the British Library, 2001), p. 358 (Vol 351) and *ibid.*, Mosley, *A Dictionary of Punchcutters for Printing Types*, p. 32, *ibid.*

three sets of Hebrew matrices held at present in the Cabinet des Poinçons, none of which appear to correspond to this No. 2 Hebrew.⁵¹¹

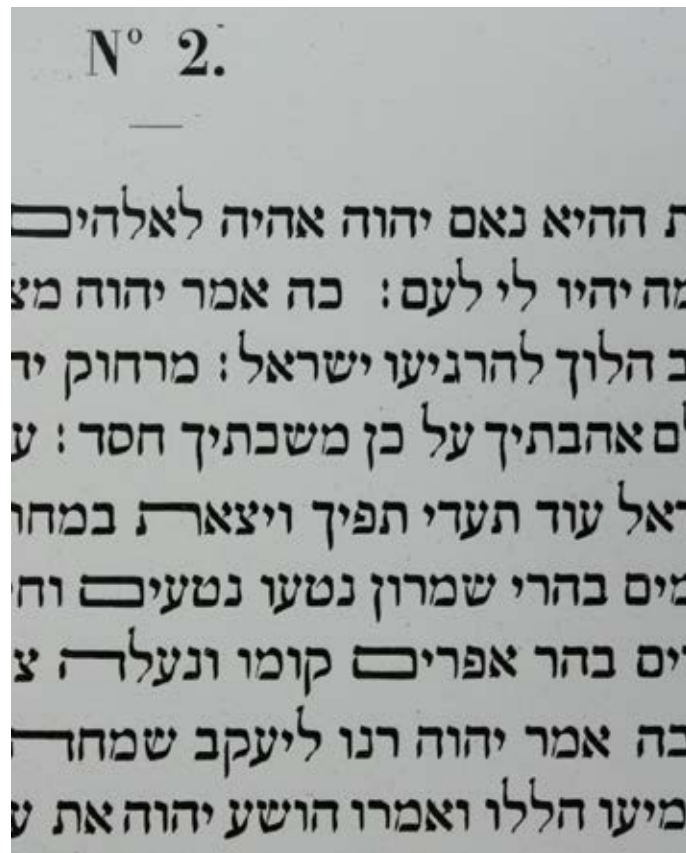

Fig. 3.41: Specimen of Hebrew No. 2 from *Spécimen des types français et étrangers de l'imprimerie Nationale*, 1855 Actual Size (By permission of Mme Nelly Gable, Le Cabinet des Poinçons)



Fig. 3.42: Partially assembled alphabet from *Spécimen des types français et étrangers de l'imprimerie Nationale*, 1855 Actual Size (By permission of Mme Nelly Gable, Le Cabinet des Poinçons)

Attributions for this typeface in printed editions:

- *Biblia Regia*, Antwerp, 1569-72
- *Epitome thesauri linguae sanctae*, Antwerp, 1570

⁵¹¹ I am indebted to Mme Nelly Gable, Graveur et Responsable du Cabinet des Poinçons and to M. Didier Barrière, Bibliothécaire of the Cabinet des Poinçons, for their assistance in providing images of these rare specimens and for their kindness in replying to my various queries. Mme Gable's inventory of the Hebrews in the Cabinet des Poinçons is as follows : Corps 6/14 gravé par Marcellin-Legrand (73 poinçons + 9 accents); - Corps 6 gravé par Aubert 1879 (45 poinçons); - Corps 8 gravé par Aubert en 1879 (45 poinçons + 1 accent); - Corps 11 gravé par Lek en 1923 (poinçons signés)-(55 poinçons + 26 accents); - Corps 14 (9/5) gravé par Lek (poinçons signés)-(55 poinçons. + 27 accents); - Corps 9/17 (9+8) gravé par Bertrand Lœuillet en 1858 – (38 poinçons)- Corps 24 (12+6+6) gravé par Louis Gauthier (68 poinçons.+ 1 accent). She also lists the following sets of Hebrew matrices: Hébreu Villeneuve sans corps; Hébreu Villeneuve 6pts; Hébreu Marcellin-Legrand 6pts, 8pts, 11pts, 16 pts, 30pts. Email of 4 April 2013 from Mme Nelly Gable.

- *Sefer Tehilim*, Antwerp, Plantin, 1581
- *Hinukh hoc est Catechesis*, Leiden, Raphelengius, 1591
- *Libellus Ruth cum Scholis Masorae*, Paris, Guillaume II Le Bé, 1609
- *Linguae Hebraicae Institutiones Absolutissime*, Paris, Guillaume II Le Bé, 1609
- Ya'akov ben Asher, *Arba'ah Turim*, Hanau, Hans Jakub Henne, 1610?
- *Psalmus Primus cum Commentarijs*, Paris, Guillaume II Le Bé, 1612
- *Biblia Hebraica*, Leiden, Raphelengius, 1613
- *Behinat HaOlam*, Paris, Laqueray, 1629
- Philippe d'Aquin, *Dictionarium absolutissimum*, Paris, Antoine Vitré, 1629
- *Biblia: 1. Hebraica: 2. Samaritana*, Paris, Antoine Vitré, 1645
- *Glossarium Universale Hebraicum*, Paris, Imprimerie Royale, 1697

Hb14 (S)

Appears on NAF 4528 folios 10, 11, and 13 and Rés X 1665, folios 1, 5v and 6
Size: Canon or Gros Canon or Grosse Lettre (Vervliet = Two line Great Primer (Trismégiste),
Double Parangonne Hébreu
Type Classification: Square Sephardic unpointed and pointed
Measurements: x-height of 6 mm; 10 lines = 24 mm (Vervliet = 20:25 pointed)
Date of creation: 1565/1566 in Paris
Punchcutter: Guillaume I Le Bé (his twelfth numbered)
Materials preserved: In MPM = MA18 (Double Parangonne Hébreu)
Type Specimens: Vervliet notes specimens in the Cabinet des Poinçons; The Plantin Folio
Specimen of 1585 No. 89 (Double Parangonne?)
Literature: Vervliet *Conspectus*: 401/Hb 6 Le Bé's two line Great primer Hebrew or Trimégiste) In
Fuks = Raph Sq. 1, Parker, Melis, Vervliet 1960, p. 42, Le Bé *Inventaire après décès c. 1617*
(Hebreu canon mon père) – probable attribution
First occurrence: *Hamishah Humshe Torah*, Antwerp 1573?

In the 1730 Le Bé Inventory there are two sets of matrices entitled 'hébreu canon mon pere' (37 and 90 matrices) and one set of punches entitled 'hébreu Canon mon pere', with 35 punches listed.⁵¹² The identity of the 90 matrix set is a mystery, as Le Bé cut only one typeface of this size according to the two Paris documents, and 90 matrices would only make sense, if it included a typeface of normal characters with dagesh points, separate vowel points and cantillation marks. The set of 37 matrices is most probably the set now found in the Plantin Moretus archives in Antwerp (MA18), which has 38 matrices in total. Plantin cast this on a Double Parangonne body and can be seen in the Canon specimen in the 1585 Folio Specimen.⁵¹³

Parker, Melis and Vervliet note that Plantin paid the letter founder Herman Grater to justify 41 Hebrew matrices in July 1569 and to cast 60 pounds of type. In addition the punchcutter Hendrik van den Keere was paid to justify four Hebrew points in April 1571 and indeed there are four matrices for vowel points – segol, kametz, shva and patach, which are different in size to the main characters. This may imply that Le Bé supplied strikes to Plantin which were then justified. All of the matrices have a notch at the bottom end which was used to attach a small piece of leather, 'and stuck to the wood of the mould with cobbler's wax during casting, so as to allow the matrix to fall far enough to allow the cast types to be ejected from the mould'.⁵¹⁴ This addition to the casting technique may not have been common in the sixteenth century, as only two of the matrices have these notches and they may be later

⁵¹² Fournier and Morison, *L'Inventaire de la Fonderie Le Bé*, pp. 22, 25. This was presumably based on the c. 1598 inventory and thus the references to feu mon pere (my late father) were written by Guillaume II Le Bé.

⁵¹³ Parker, Melis, and Vervliet, *Typographica Plantiniana II*, p. 42. See also Dreyfus, *Type Specimen Facsimiles II Nos 16-18*, p. 11 (No. 89)

⁵¹⁴ Morison and Carter, *John Fell, the University Press and the "Fell" types*, p. 257. See also Plate II in the Diderot d'Alembert *Encyclopédie* (Imprimerie/Relieure) which shows a view of an assembled hand mould with a matrix inserted into the mould and attached with a small leather strip tied to the two notches at the bottom end. The explanation to the plate says that this is the 'attache de la matrice. C'est une petite bande de peau de mouton'. See Denis Diderot and Jean-Baptiste le Rond D'Alembert, *L'Encyclopedie: Imprimerie-Relieure* (Paris: Bibliotheque de l'Image, 2001)

additions. There is also a small circular indent above the notch which could also serve the purpose of holding the metal spring in place during casting. These appear to have been drilled and not struck, as there is no burr around the edge of the hole.

There are three further interesting points about these matrices. The dagesh points appear to have been drilled in a separate operation, and the character ayin is open to the side of the matrix on the descender. This was probably to allow a closer fit for the adjacent characters, although the ayin on the sixth row of the specimen must have been kerned to allow it fit under the bet. Finally the final kapf (ך) has horizontal slots on the front and rear of the matrix. It is not clear what the function of these slots was, but it points to the hand of another punchcutter.

The conclusion that Parker *et al* draw from these facts is that this typeface was first used in the Plantin Polyglot Bible, but a closer examination does not bear this out. The Canon size Hebrew used on the Hebrew title page and on the first page of the Biblical texts (Genesis) is in fact Hb24 (S), a typeface that Le Bé attributes to Jacob of Mantua and was already in the possession of Plantin by 1567, as it appears in the *Index Characterum*. It most probably came to Plantin along with the other Bomberg types which he received in 1563 with the establishment of the partnership with Becanus, de Schotti, and the van Bomberghens.⁵¹⁵ Hb13 (S) appears on the title page of Plantin's Hebrew *Pentateuch* of 1573 and this may well be the first appearance.⁵¹⁶



Fig. 3.43: MA 18 Matrices. Front view. Reduced 60 per cent (Museum Plantin-Moretus/Prentenkabinet)



Fig. 3.44: MA 18 Matrices. – Rear view. Reduced 60 per cent (Museum Plantin-Moretus/Prentenkabinet)

⁵¹⁵ Parker, Melis, and Vervliet, 'Typographica Plantiniana II', pp. 15, 42, *ibid*.

⁵¹⁶ Voet and Voet-Grisolle, *The Plantin Press, 1555-1589: a bibliography of the works printed and published by Christopher Plantin at Antwerp and Leiden*, p. 329 (No. 652). The annotation to the side of the specimen, (cecy est ce que l'on veult) in another hand, suggests that the specimen was shown to a potential client and that it met with his approval.



Fig. 3.45: HB14 (S): Assembled alphabet enlarged to 10 mm appearing size



Fig. 3.46: HB14 (S): Assembled alphabet at actual size



Fig. 3.47: HB14 (S): Assembled alphabet of MA 18 (Museum Plantin-Moretus/Prentenkabinet)

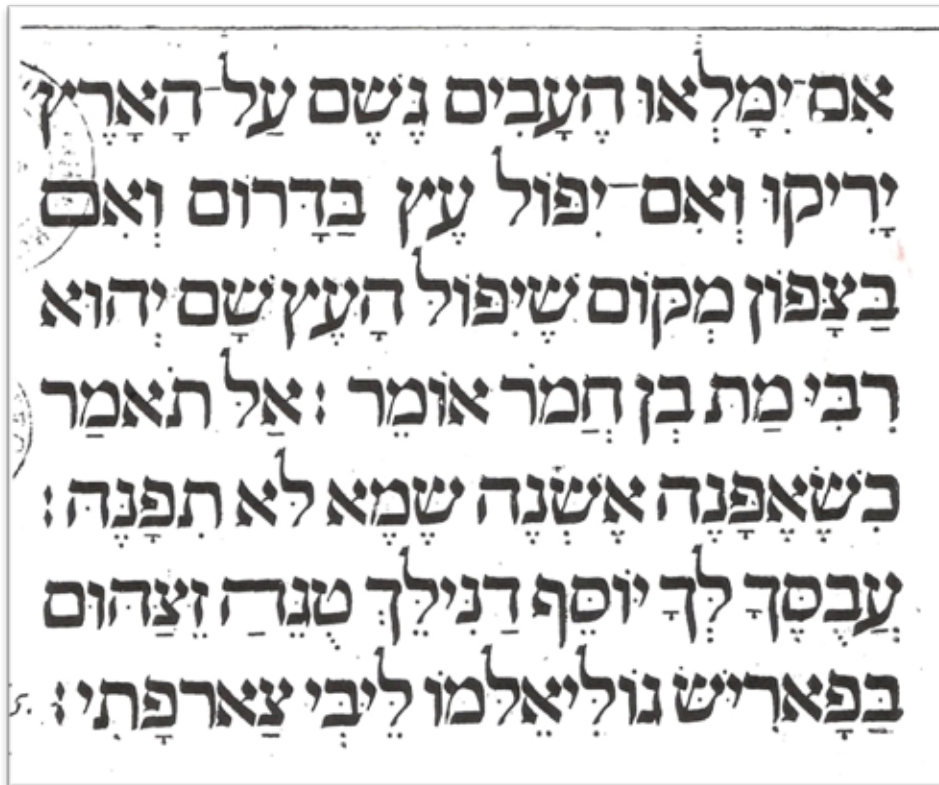

Fig. 3.48: HB14 (S): Le Bé specimen from NAF4528 f. 11 (actual size)

The text of the specimen itself is a curious mixture of actual and invented text. The first three lines are from Ecclesiastes 11:1. The fourth and fifth lines are from the Mishnah, *Pirkei Avot* (Sayings of the Fathers) 2:5, with erratic vowel settings. The name on the fourth line (Rabbi Matt ben Hamur) which means literally ‘Rabbi Matt son of an Ass’ and could well be satirical, but it raises the question where Le Bé would find this name or who would have given it. It is clearly not a name that a Jew would have chosen, but possibly a Christian Hebraist or student active in Paris at that time, such as the *Collège Royale* professors Jean Cinquearbres, Gilbert Générard, the cabbalist Guillaume Postel, or the brothers Guy and Nicholas le Fèvre de la Broderie, who were involved in the production of the Antwerp Polyglot Bible.⁵¹⁷ The final line is Le Bé’s usual signature: *BePariz Gulielmo Lebay Tsarfati* (in Paris by Guillaume Le Bé a Frenchman).

This typeface appears in three instances in the Plantin inventories: 1572, 1590 (Leiden) and 1652. The entry in the 1590 Leiden inventory explains the use and transmission by Raphelengius and Johannes le Maire. In the 1652 inventory it is listed under *Hebreusche Matrysen* as 38 Dobbel Parangon Hebreusche.⁵¹⁸ In Paris in the seventeenth century it was used in the Vitré Polyglot Bible and as late as 1753 in the *Biblia Hebraica* printed by Briasson and Durand.

⁵¹⁷ I am grateful for the assistance of Dr Jeremy Schonfield of the Oxford Centre for Hebrew and Jewish Studies for his suggestions on the text, and to Dr. Stephen Burnett of the University of Nebraska-Lincoln for his suggestions on Christian Hebraists active in Paris in the 1570s.

⁵¹⁸ Parker, Melis, and Vervliet, *Typographica Plantiniana II*, p. 114



Fig. 3.49: MA 18 as used in the 1753 *Biblia Hebraica*, Paris. (By courtesy of the John Rylands University Library, Manchester, SC2407E)

This Le Bé type is also extremely close in style to the Double Pica Hebrew found amongst the OUP Fell types. Morison attributes the No 2 Double Pica Hebrew to the Dutch punchcutter Arent Corneliszoon van Hogenacker of Leiden (c. 1579 – 1636) and also notes that the five extended characters could be attributed to the London typefounder Nicholas Nicholls.⁵¹⁹ John Lane has written on this type that ‘the model for Hogenacker’s Hebrew types is clear. They are close copies of the sixteenth-century Hebrew types cut by Guillaume Le Bé in Paris’.⁵²⁰

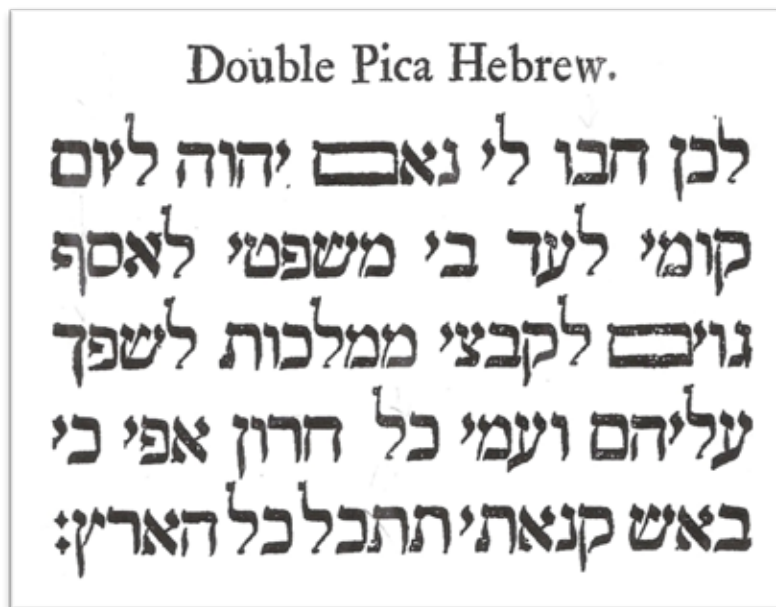

Fig. 3.50: Double Pica Hebrew from 1695 OUP *Specimen of the several sorts of letters* (By permission of Lambeth Palace Library YC911 4.01)

⁵¹⁹ Morison and Carter, *John Fell, the University Press and the "Fell" types*, p. 234

⁵²⁰ John A. Lane, 'Arent Corsz Hogenacker (ca. 1579-1636) an account of his typefoundry and a note on his types Part two: the types', *Quaerendo*, 25/3 (1995), pp. 177-178

There is another possible connection to Hb14 (S) which was first noticed by Harry Carter. In the specimen book issued by Adophe René in Paris in 1858, there are four Hebrews – a Corps 13, a Corps 18, a Corps 22 and a Rabbinique Corps 11 – all of which Carter linked to Le Bé's Hebrews in NAF 4528. In 1966 Carter wrote to the French typefoundry Deberny & Peignot and asked for further information about these Hebrews. He was told that 'René Corps 13 is now Peignot Corps 12 (matrice 15216)' and that 'the Corps 22 still exists: matrices No. 15207'. Deberny & Peignot was founded in 1923 by the merger of the two eponymous foundries and in 1972 was bought by Haas in Switzerland. Vervliet thought that the matrices could be held in the Cabinet des Poinçons, but at present this seems doubtful. Further enquires in Switzerland and in the Cabinet des Poinçons brought no further information as to the whereabouts of these matrices. The resemblance to Hb14 (S) is very clear and raises the possibility that they might have come from matrices in the Le Bé foundry and somehow made their way through various Parisian foundries to Deberny & Peignot. Alternatively they may be recuttings made based on the Le Bé originals.⁵²¹

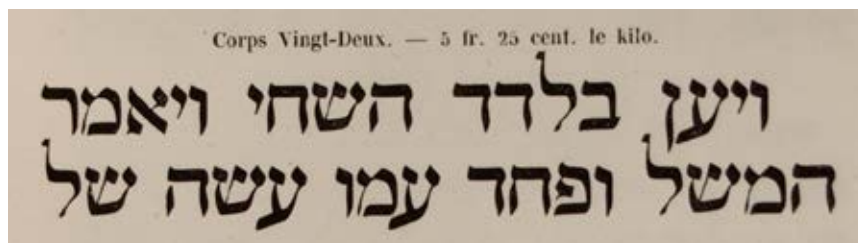

Fig. 3.51: Hebrew Corps 22 from the 1858 *Epreuves des Caractères*, Adophe René, *Fonderie Générale* Actual size (St Bride Printing Library)



Fig. 3.52: Hebrew 15207 with and without vowels from the 1924 Deberny & Peignot specimen book. Actual size (Bibliothèque Forney, Paris)

⁵²¹ See Adophe René, *Epreuves de Caractères* (Paris: Fonderie Générale des Caractères Français et Etrangers, 1858) and Deberny et Peignot, *Caractères étrangers / fonderies Deberny et Peignot*. Vol. Fascicule 1 (Hébreu) (Paris: Deberny et Peignot, 1924). I am indebted to Hendrik Vervliet for letting me see the letter from Harry Carter to him, as well as to the librarian of the Bibliothèque Forney in Paris for the 1924 Deberny & Peignot Hebrew specimen.

Attributions for this typeface in printed editions:

- *Sefer Kol-Bo*, Venice, di Cavalli, 1567?
- *Bible*, Antwerp, Plantin, 1573
- *Iosuae Imperatoris Historia*, Antwerp, Plantin, 1574
- *Sefer Tehilim*, Antwerp, Plantin, 1581
- *Biblia Hebraica*, Antwerp, Plantin, 1582
- *Hagadah shel Pesach*, Venice, Israel ben Daniel Zifroni, 1606
- Hugh Broughton, *Patshegen Nishtevan*, Amsterdam, 1606
- *Linguae Hebraicae Institutiones Absolutissime*, Paris, Guillaume II Le Bé, 1609
- Abraham ben David Portaleone, *Sefer Shilte ha-giborim*, Mantua, 1612?
- *Psalmus Primus cum Commentarijs*, Paris, Guillaume II Le Bé, 1612
- *Biblia Hebraica*, Leiden, Raphelengius, 1613
- *Sefer Tehilim/Psalterium*, Leiden, Raphelengius, 1615
- *Sefer Tehilim*, Leiden, Raphelengius, 1615
- *Grammatica Ebraea Generalis*, Leiden, Raphelengius and Le Maire, 1621
- *Samuelis libri duo*, Leiden, Johannes Le Maire, 1621
- *hoc est Arcanum punctationis revelatum*, Leiden, Johannes Le Maire, 1624
- *Behinat HaOlam*, Paris, Laqueray, 1629
- Philippe d'Aquin, *Dictionarium absolutissimum*, Paris, Antoine Vitré, 1629
- Johann Rittangel, ספר יצירה *id est Liber Ierzirah*, Amsterdam, Apud Johannum et Jodocum Ianssonios, 1642?
- *Biblia Hebraica, Samaritana. Chaldaica, Graeca*, Paris, Antoine Vitré, 1645
- *Glossarium Universale Hebraicum*, Paris, Imprimerie Royale, 1697
- *Biblia Hebraica*, Paris, Briasson and Durand, 1753

Hb15 (S)

Appears on NAF 4528 folio 12

Size: Petite lettre Hébraïque texte hebreu, Vervliet = Minion Hebrew [HB 1,1] or Mignonne

Type Classification: Square Sephardic unpointed

Measurements: x-height of 1 mm; 5 lines = 9 mm (Vervliet = 1.1 mm and 20:45)

Date of creation: 1569/70 in Paris

Punchcutter: Guillaume I Le Bé for Christophe Plantin (his 15th numbered)

First use: Bible. O.T. (*Hamishah Humshe Torah*. 1573-74). Plantin, Antwerp

Materials preserved: ST55, MA 82a and MA 83a at the MPM

Type Specimens: 1585 Folio specimen (no. 77), Omont, 1887, 280, no. 15

Literature: *Index characterum architypographiæ Plantinianæ*, 1905, (Colineus Hebreuwsch);

Vervliet-Carter, 1972, II, No. 17 Plantin's Folio Specimen, c. 1585, No. 77; *Letters proven*, 2004, pp. 88-89; Vervliet *Conspectus 2010*: 366/ Le Bé's Minion Hebrew [Hb 1.1] or Saint-Augustin

First Occurrence: *Biblia Hebraica*, Plantin, 1573

This typeface was the result of a direct commission from Christophe Plantin to Guillaume Le Bé and it appears that Le Bé sent only the punches (ST55), from which matrices were struck and justified by Hendrik van den Keere in 1571.⁵²² Plantin asked Le Bé 'de la fayre la plus petite que je pourroye'.⁵²³ This would perhaps explain why Le Bé notes that 'je n'en ay peu recouvrer d'autre espreuve'.⁵²⁴ The specimen that Plantin sent to Le Bé is a pointed text and Le Bé comments that 'Je ne sçay d'ou est ce petit hébreu que je reçeu de Plantain pour luy en faire un plus petit; il m'en envoya ce demy feuillet, et n'en ay point veu à Venise, ny Rome, ny autrepars'.⁵²⁵ It should be noted here that this is first of three requests for Hebrew types which Le Bé received from Christophe Plantin. The second resulted in Hb46(S) and the third (undated) was a request to produce a copy of a Bomberg – see Hb35 (S) – which Le Bé was unable to fulfil as he 'neuz lors loisir de faire'.

There are two sets of matrices relating to this typeface and, according to the inventory of the Hebrew material in the MPM, the matrices justified by van den Keere is MA82a and contains 36 matrices. MA 83a contains 30 matrices and is listed as *Colonel alias Petit Hebreus* in the 1652 inventory.⁵²⁶ In the inventories kept in the Plantin Moretus, this typeface is first mentioned in 1572 (ST55 and MA82a), then in 1581, possibly in the Leiden inventory of 1590, and finally in 1652 as listed as a *Jolie Hebreusch*. In the 1595 Plantin folio specimen, this type is named as 'Hebrieu sur la Coronelle'.

⁵²² Parker, Melis, and Vervliet, *Typographica Plantiniana II*, p. 45. See also Plantin-Moretus Museum, *Letters proeven/Letters smaken/La saveur des caractères/Le goût des estampes* (Antwerpen: Museum Plantin-Moretus 2004), p. 88

⁵²³ To make it as small as I could.

⁵²⁴ I was not able to obtain another specimen.

⁵²⁵ I do not know where this small Hebrew is from that I received from Plantin to make a smaller version. He sent me this half sheet and I have not seen anything like it in Venice, Rome nor anywhere else. See Rés X 1665 f.20.

⁵²⁶ Plantin-Moretus., *Inventaris van de stempels en matrijzen van het Museum Plantin-Moretus. Inventory of the Plantin-Moretus Museum punches and matrices. Eng.*, p. 118

The actual punches (ST55) are variously known as Coronelle hébreu, Grosse nonpareille, Jolie Hebreusch in the inventories and contain 33 punches. All are in Le Bé's hand and of various heights, and some have one or two horizontal incisions on the side or edge of the punch. This typeface consists of the 22 basic characters, six final characters, four extended and one punctuation sign. They vary in height from 34.1 to 48.7 mm, which does not appear unusual if they are compared to ST52, a Le Bé typeface which he might have reworked (*retailé*) in some way.⁵²⁷



Fig. 3.53: Hb 15 (S): Complete set of punches for ST 55 showing the image end. Slightly reduced in size (Museum Plantin-Moretus/Prentenkabinet)

⁵²⁷ *Ibid.*, p. 114



Fig. 3.54: Hb 15 (S): Selected punches from ST 55 showing differing punch heights and finish. (Museum Plantin-Moretus/Prentenkabinet)



Fig. 3.55: Hb 15 (S): Assembled alphabet from the Le Bé specimen enlarged to about 5 mm appearing size.



Fig. 3.56: Hb 15 (S): Assembled alphabet from the Le Bé specimen at actual size.

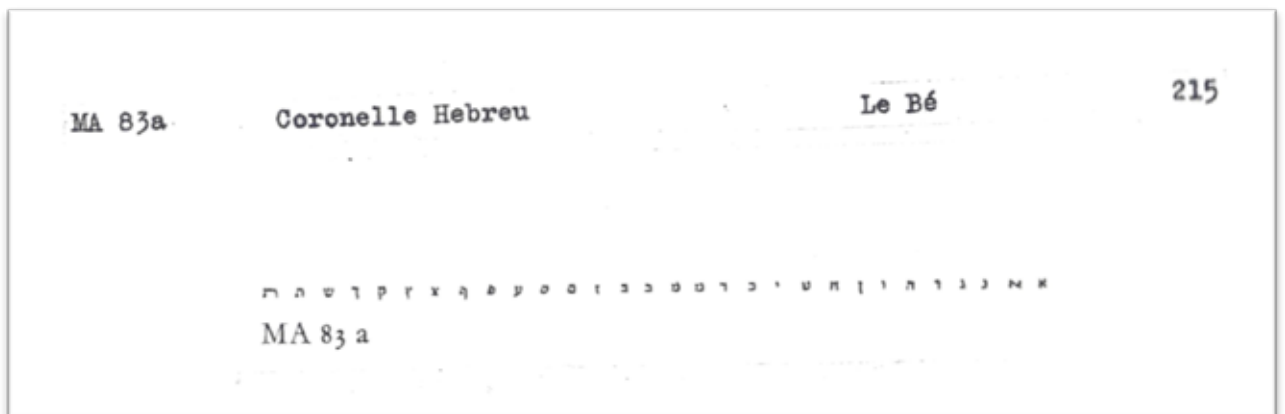

Fig. 3.57: Hb 15 (S): Assembled alphabet Actual size (Museum Plantin-Moretus/Prentenkabinet)

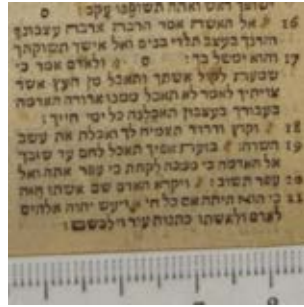

Fig. 3.58: Hb 15 (S): Setting specimen from the 1573 Plantin *Biblia Hebraica*. (By permission of the UCL Special Collections SR Mocatta 1573 B4)

The Le Bé specimen contains part of Psalms 79:1-5 (A Psalm of Asaph) in lines one to six, a complete alphabet in lines six and seven, and random characters in the final two lines. The only use of this typeface found to date is in the 1573 Plantin *Biblia Hebraica*.

Hb16 (R)

Appears on NAF 4528 folio 9v and Rés X 1665, folio 21v

Size: Petit Glose

Type Classification: Rabbinical (Rashi) unpointed

Measurements: x-height of 1 mm; 10 lines = 24 mm

Date of creation: 1570 in Paris

Punchcutter: Guillaume I Le Bé (his 13th numbered)

Type Specimens: MPM Archive Franç.-flamand, n° 153. *Fondeurs de caractères 16e siècle.*

Literature: Vervliet, 2010 (No. 367. Le Bé's Rabbinical Hebrew on Brevier [Hb 1.2] or petit texte), Vervliet and Carter, *Type Specimen facsimiles II*, 1972, No. 18 Le Bé-Moretus Fragments c. 1599, no. 27, *Le Bé Inventaire après décès c. 1617* (Glos Hebraique Petit texte mon père) – probable attribution

Le Bé dates this Rashi Script to 1570 and calls it a petit glose, which does not relate to a known size, whereas Vervliet classifies it as Old English Brevier, or Old French Petit texte, which is equivalent to 7 pt. Didot or 7.5 pt. Anglo-American. It is the smallest Rabbinical Hebrew cut by Le Bé, no doubt prompting him later to engrave Hb 15 (S) in the same period, his fifteenth. The presence of the aleph/lamed ligature, the swash final mem and the two punctuation marks might indicate that he designed this typeface for a full text setting.

Le Bé notes in his annotation that he cut it 'céans pour moy' may be interpreted to mean 'in this place for me', and implies that he had no purchaser in mind, as opposed to Hb 17 (S), which was cut on the request of Christophe Plantin in Antwerp. Such a small size usually appears as a superscript reference to marginal notes or as a side reference itself. This can be seen, for example, in a Bible printed by Bragadin in Venice in 1590/91.⁵²⁸ Le Bé also notes that he sent a set of matrices (perhaps a strike) to Venice, but to date no examples of this typeface have been found in any Italian Hebrew editions. This is evidence that he kept up his connections with Italy after his return to Paris and also evidence for a trans-national trade in the sale of typefaces.

The text of the specimen is from the *Mishnah* (Masekhet Avot, Chapter 4). The heading is Le Bé's fifth type, Hb7 (R) which he engraved in 1547. Lines 1 through 8 are from this text, whereas line 9 appears to be nonsense and there mainly to show several final characters. In particular there is an extended final mem in this line with an extended horizontal stroke. The final line of the specimen contains the words in Hebrew 'BeParis Gilielmo LeBay Tsarfati asa' or Made in Paris by Guillaume Le Bé. This was engraved during the third war of the French Wars of Religion, which may have affected Le Bé's ability to sell his types.⁵²⁹ Later in 1591, after the siege of Paris, Le Bé relates in some detail in his annotation the circumstances in which he worked and his need to have 'de l'argent pour vivre'.⁵³⁰

⁵²⁸ Bible, OT Pentateuch, Venice: Bragadin, 1591 (BL ORB 30/2408)

⁵²⁹ For a discussion of how the Wars of Religion affected Le Bé's native city of Troyes during this period, see Roberts, *A city in conflict*, pp. 123-141

⁵³⁰ NAF 4528 folio 16. See also Pierre de L'Estoile and Philippe Papin, *Paris pendant les guerres de Religion: extraits de ses registres-journaux, Collection "Histoire"* (Paris: Arlea, 2007)

The specimens in NAF 4528 and Rés X 1665, although identical in the text, appear to differ slightly in leading. This may indicate that they were cast on a different mould. There is no annotation relating to the second specimen in Rés X 1665, folio 21v.

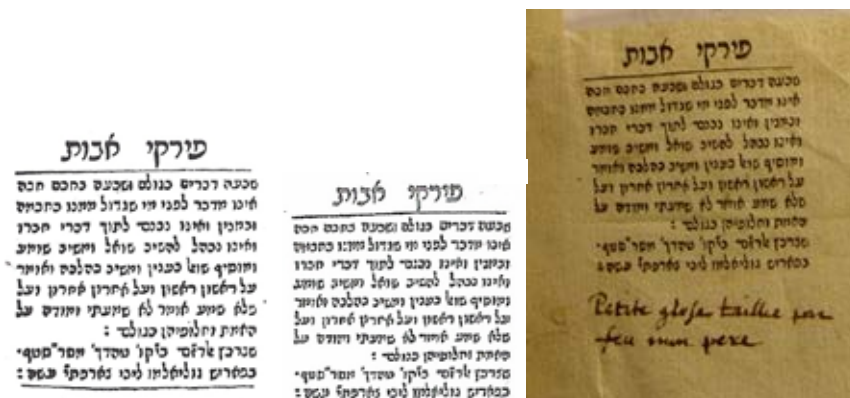

Fig. 3.59: Hb 16 (R) Specimens from NAF 4528 folio 9v (Left and top), Rés X 1665, folio 21v (centre) and the 1599 MPM specimen (right) The PM specimen has an annotation by Guillaume II Le Bé.





The complete alphabet and key letter recognition factors are as follows:



Fig. 3.60: Hb 16 (R): Complete assembled alphabet enlarged to 5 mm x-height

אבגדהוזחטיכךלמםסנו
פעפףצקקרתא"ף

Fig. 3.61: Hb 16 (R): Complete assembled alphabet at actual size of 1 mm x-height

-  Aleph: The oblique upper stroke joins the horizontal stroke further to the right. This may be a later characteristic of Le Bé's designs, as the first Rabbinical – Hb2(R) – has the join almost directly above the right vertical.
-  Koph: The left vertical stroke has a definite swell and oblique termination.
-  Tav: The left vertical stroke has a distinct angle.
-  Aleph/Lamed ligature: Similar to others ligatures of its type but its very presence indicates a possible use for longer text setting
-  Extended final mem: The upper horizontal stroke extends well beyond the actual type body.

This extended final character could be termed as what is now known as a swash character. Such characters are not without precedent in Hebrew typography and can be seen in incunabula editions printed in Hija in Spain in 1485 and in Lisbon in

Portugal in 1489.⁵³¹ It is possible that Le Bé would have seen similar editions either in Venice or in Paris and used them as his models. There are similar examples in Hb18 (R).

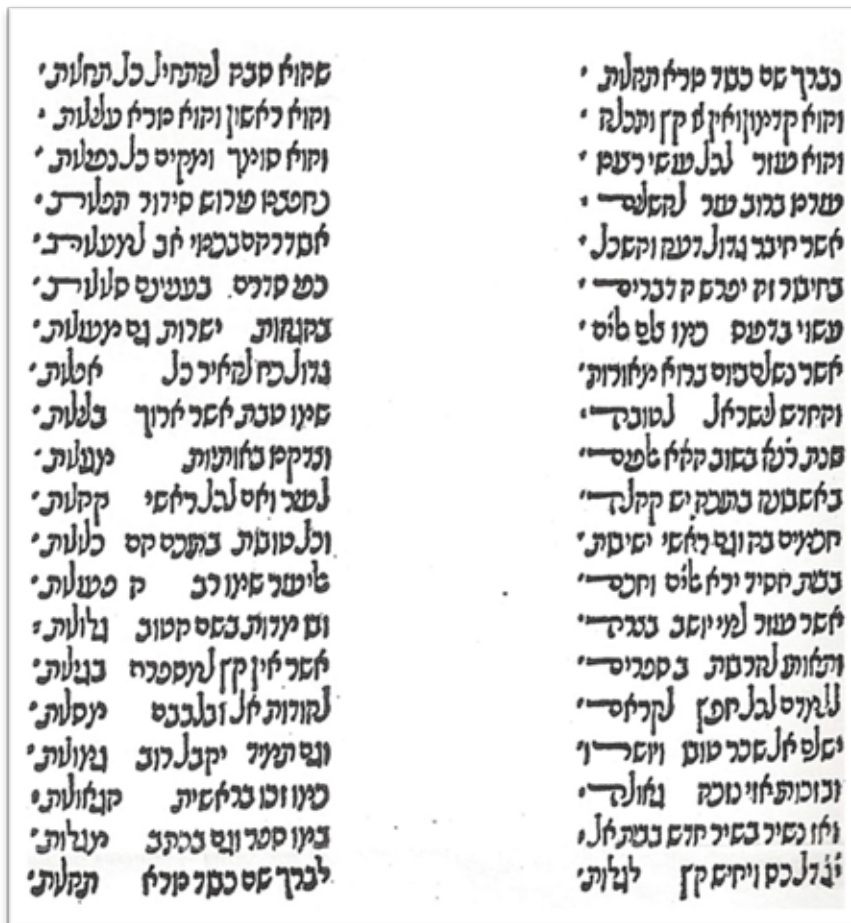

Fig. 3.62: Detail of semi-cursive Hebrew from Lisbon Pentateuch. Actual Size (From Freimann and Marx, *Thesaurus typographiae Hebraicae saeculi XV*, plate B19.8)

Note the final mem (𐤀) characters in the right hand column which are similar to Le Bé's HB18 (R). This page also shows the use of other extended characters, such as the resh and heh (ה). This type is a very close copy of a typical Sephardic semi-cursive hand.⁵³²

⁵³¹ Freimann and Marx, *Thesaurus typographiae Hebraicae saeculi XV*, pp. B8-1, B26-21. See also A. Freimann, 'Die Hebräischen Inkunabeln der Druckereien in Spanien und Portugal', *Gutenberg-Jahrbuch* (1925)

⁵³² Sirat and De Lange, *Hebrew Manuscripts*, pp. 190-195

Hb17 (S)

Appears on NAF 4528 folios 14v and 15

Size: Not identified, Vervliet = Le Bé's Hebrew on twelve-line Pica [Hb 35]

Type Classification: Square Sephardic unpointed

Measurements: x-height of 31 mm (Vervliet = 35 mm)

Date of creation: 1573 in Paris

Punchcutter/wood engraver: Guillaume I Le Bé and Machiel du Boys (unnumbered, but number 18 in this thesis)

First use: No known uses

Materials preserved: None

Type Specimens: NAF 4528 folios 14v and 15 only

Literature: Vervliet *Conspectus*: 406 Le Bé's Hebrew on twelve-line Pica [Hb 35]; Omont,

Spécimens de Caractères Hébreux, Grecs, Latins et de Musique, 1889, No. XV bis

This is the largest of the typefaces created by Le Bé and it is not obvious to what uses such a 'monumental' size could be put. The largest sizes of *cast* letters used in Venice, Paris and Antwerp during the sixteenth century for text on title pages or chapter openings are usually no larger than 16 mm in appearing size.⁵³³ Where larger sizes were used, they were normally *incised* initial letters in wood, such as those seen in Antwerp drawn by the Paris engraver Geoffrey Ballain (or Ballaing) and those engraved by Cornelis Muller, or in the initial characters of the Paris polyglot of LeJay of 1645.⁵³⁴ Another good example of these large initial letters can be seen in the *Hagadah* printed in Venice in 1609 by Israel ben Daniel Zifroni. They were produced with Passover themes in mind, and follow the Sephardic style.⁵³⁵ It may be that Le Bé had such uses in mind when he produced this alphabet.

A possible use of these monumental sizes of Hebrew, although it is unlikely that Le Bé would have known of this tradition, was to emphasize important elements in the text, such as benedictions. These can be seen in the mid fifteenth-century *Ashkenazi Haggadah* manuscript, for example on folios 1b, 35a, 37b, 39a, 43a, 45a, and 46b where initials up to 50mm in height are used.⁵³⁶

⁵³³ See the examples of incised 'introductory' letters in Réx X 1665 f. 17. This specimen is from the Bomberg 1523 Bomberg Jerusalem Talmud, the first page of the Tractate Demai.

⁵³⁴ Voet, *The Golden Compasses*, pp. 199-201

⁵³⁵ Narkiss and Modena, *Seder Hagadah shel Pesach, Venetsyah 369 = The Passover Haggadah, Venice 1609*

⁵³⁶ David Goldstein, Joel ben Simeon, and Eleazar ben Judah of Worms, *The Ashkenazi Haggadah: a Hebrew manuscript of the mid-15th century from the collections of the British Library*. New ed. (London: Thames and Hudson, 1997), pp. 14-15. Larger founts could also be used for the Kiddush Levanah, or sanctification of the moon, which is recited once a month when the full moon is visible. I am grateful to Dr Jeremy Schonfield for this clarification.



Fig. 3.63: (Left) Initial letter Bet engraved by Ballaing from the *Index characterum Typographiae* (No. 3) (Actual Size) Right: Initial letter Bet from the Paris Polyglot of Le Jay of 1645. (Actual Size) (By permission of the MPM and the John Rylands Library, Manchester)



Fig. 3.64: Initial letters from Venice Hagadah 1609, printed by Israel ben Daniel Zifroni (Actual Size) From *Seder Hagadah shel Pesach, Venetsyah 369 = The Passover Haggadah*, Venice 1609. The original is in the Jewish National and University Library in Jerusalem.

The final paragraph of the annotation notes that part of this alphabet was engraved in wood by one 'Mahiel du Boys' and this, according to Vervliet, is not the Michel Du Boys who lived from c. 1510 to 1561 and whom Le Bé credits Hb23 (S), but Mahiel Du Boys, a dominotier, or maker of marbled papers.⁵³⁷

The first two paragraphs of the annotation are important as they provide confirmation of Le Bé's knowledge of and involvement in Hebrew letterforms. According to these comments, he made good use of his time in Venice to consult with Jewish scribes and possibly other engravers who dealt with Hebrew typefaces. He may also have used collections of Hebrew manuscripts in Venice available in the sixteenth century, such as the library belonging to Cardinal Domenico Grimani, which consisted of some 193 volumes. Some of these volumes came from the Christian Hebraist Giovanni Pico della Mirandola.⁵³⁸ This is at present a hypothesis, but what little he says does point to a curiosity and interest in such matters. He also appears to have brought back with him to Paris sketchbooks of letterforms which he

⁵³⁷ Richard J. Wolfe, *Marbled paper: its history, techniques, and patterns: with special reference to the relationship of marbling to bookbinding in Europe and the Western world* (Philadelphia: University of Pennsylvania Press, 1990), p. 33. See also Vervliet, *French Renaissance Printing Types: A Conspectus*, p. 41.

⁵³⁸ Giuliano Tamani, 'I Libri ebraici del Cardinal Domenico Grimani', *Annali di Ca' Foscari*, XXXIV (1995)

had seen and later used. This period in Venice and Rome would have exposed him to aspects of Jewish culture not available to him later in Paris and he obviously came to it with a surprising lack of prejudice for the period.

There is no record of this typeface being used in any printed edition nor of its presence in the later Le Bé typefoundry, thus do they appear to have disappeared at some point before the sale of the Foundry. This is confirmed by the fact that Le Bé makes no mention of a sale to another printer or typefounder.

The large size of this typeface gives an accurate depiction of Le Bé's 'late mature style', if it can be so called. The letterforms are strongly influenced by pen shapes, well modulated in their transitions from vertical to horizontal strokes, and with a clear eye to the differentiation of similar letterforms, such as the bet and kapf, dalet and resh, samekh and final mem. It is interesting to observe in the specimen that the ascender of the lamed overlaps the left stroke of the chet, and Le Bé has not pasted down this element, but left a flap to lift up on the specimen.



Fig. 3.65: Hb 17 (S) Unretouched Assembled alphabet from NAF 4528 folio 14v-15 (Reduced 50 per cent)

Hb18 (R)

Appears on NAF 4528 folios 9v, 10, 11v and 12v; and Rés X 1665, folio 6

Size: Glose (cast on St. Augustin body)

Type Classification: Rabbinical (Rashi) unpointed

Measurements: x-height of 2.3 mm; 10 lines = 24 mm

Date of creation: 1574 in Paris

Punchcutter: Guillaume I Le Bé (his 14th numbered)

Materials preserved: M135a in MPM

Type Specimens: MPM 1599 specimen [Folio 20c]

Literature: Vervliet *Conspectus*: 379 Le Bé's Rabbinical Hebrew on English [Hb 2.3], Le Bé *Inventaire après décès* c. 1617 (Glos Hebraïque St Augustin mon père) – probable attribution

First Occurrence: *Linguae Hebraicae Institutiones Absolutissime*, Paris, Guillaume II Le Bé, 1609

This specimen occurs in four different folios of the two Le Bé documents. The complete specimen is repeated and dated in 4528 folio 10 and 1665 folio 6, whereas the same type is used in 4528 folio 11v and 12v as headings. Le Bé calls this a 'glose' in the annotation on 1665 folio 6 and mentions it, without any further comments, on 4528 folio 20. In the 1599 Le Bé-Moretus fragments, part of the whole specimen is shown with an added handwritten annotation by Guillaume II Le Bé 'Glose Hebraïque a fondre sur le St. Augustin taillé de feu mon pere'.⁵³⁹

The 1730 Le Bé inventory does list a set of 42 punches for a 'Glose Hébraïque St. Augustin mon pere' and two similar named sets of 44 matrices each.⁵⁴⁰ It is a fair assumption that these punches and at least one set of matrices relate to this typeface and remained in the Le Bé foundry until its final sale and disappearance. A very similar typeface appears in the catalogue of the Parisian Fonderie Adolphe René in 1858 – a *Rabbinique du Onze* – and includes part of the almost identical text and the final swash mem. Furthermore the same punctuation with the raised full stop and end of verse colon has been followed. These similarities could not be coincidental and point to a setting from the original matrices or at the least a very faithful copy of them from the Le Bé specimens in the BnF.⁵⁴¹ The Fonderie Adolphe René existed from 1851 to 1871 and formed part of the succession of the Fonderie Générale which incorporated many smaller French type foundries including Firmin Didot. Further research may yet reveal a connection to the Le Bé foundry, but that is beyond the remit of the present research.⁵⁴²

⁵³⁹ Dreyfus, *Type Specimen Facsimiles II Nos 16-18* (Le Bé-Moretus fragments, c. 1599 No. 26)

Hebrew gloss to be cast on St Augustin engraved by my late father.

⁵⁴⁰ Fournier and Morison, *L'Inventaire de la Fonderie Le Bé*

⁵⁴¹ René, *Epreuves de Caractères*

⁵⁴² Marius Audin, *Les livrets typographiques des fonderies françaises créées avant 1800: Etude historique et bibliographique* (Amsterdam: Gerard Th. van Heusden, 1964), p. 146

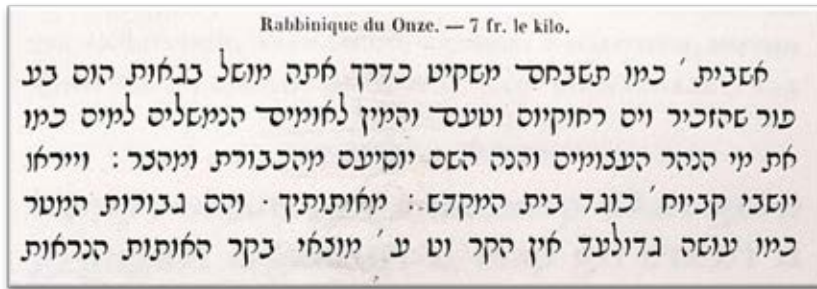

Fig. 3.66: Hb18 (R) Rabbinique du Onze from Adolphe René, *Epreuves de Caractères*, 1858

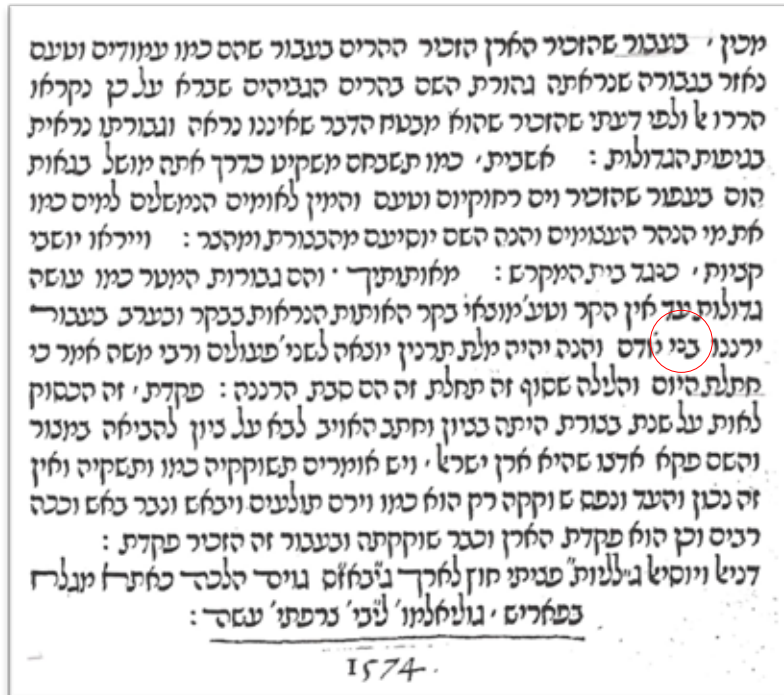

Fig. 3.67: Hb18 (R); Le Bé Specimen shown at actual size. (NAF f.10)

What is unique about this specimen are the extended final forms, which could almost be described as ‘swash’ characters, borrowing the term from swash capitals or ‘a typographical flourish on a glyph, like an exaggerated serif’.⁵⁴³ These were common in the sixteenth century and are seen, for example, in some of the typefaces cut by Granjon and Garamont.⁵⁴⁴

The example in figure 3.59 shows similar swash and extended characters from a Biblical commentary printed in Leiria in Portugal by Samuel d’Ortas and sons in 1494. The type is based on a semi-cursive Sephardic script and illustrates the condensed lamed, the ‘swash’ final mem, and the extended resh (ר) which Le Bé has added in his specimen.⁵⁴⁵ The expulsion of the Jews in 1497 from Portugal occurred soon after this publication and it is likely that Portuguese Hebrew editions such as these would have reached Venice by the time Le Bé was active there in the 1540s.

⁵⁴³ See Geoffrey Glaister and Donald Farren, *Encyclopedia of the book* (New Castle, Del.: Oak Knoll Press; London: British Library, 1996), pp. 466-467

⁵⁴⁴ Vervliet, *French Renaissance Printing Types: A Conspectus*. See No. 129 (R140) or No. 237 (It 67).

⁵⁴⁵ Sirat and De Lange, *Hebrew Manuscripts*, pp. 190-195

These forms of swash characters are also seen in Hebrew editions attributed to Samuel Netivot in Fez in Morocco from 1516 and 1517. The edition of the *Sefer Abudarham* of 1517 has examples of an extended resh, tav, lamed, extended final mem, smaller condensed final mem and final kapf.⁵⁴⁶ This provides indirect evidence for the movement of typefaces from Spain to North Africa during the period of the expulsions from Spain and Portugal. The swash characters can be seen in HB 16 (R), and this is clearly a progression on Le Bé's part in the models he has used for his types.

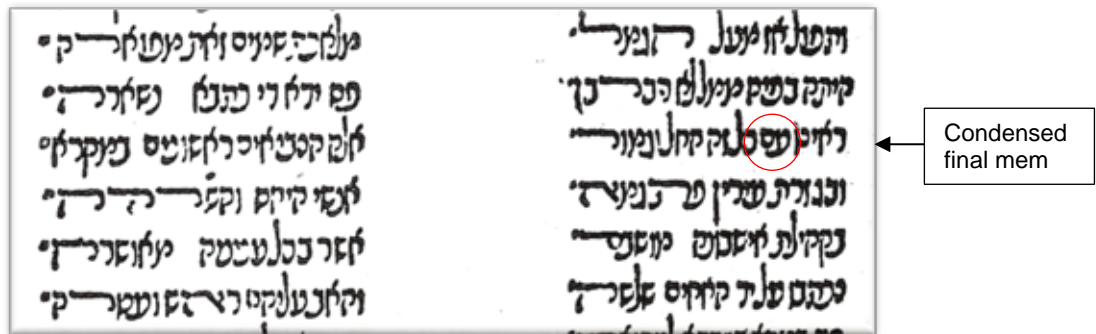

Fig. 3.68: Type specimen of Targum to the Book of Earlier Prophets from Bible printed by Samuel d'Ortas in Leiria in Portugal, dated 1494. Slightly reduced (From Freimann, *Thesaurus typographiae Hebraicae saeculi XV*, 1969, Plate B27, 5)

The text of the specimen is a commentary by the eleventh-century Biblical commentator Abraham ben Meir Ibn Ezra to the passage from Psalms which appears on the same specimen (Hb13 (S)).⁵⁴⁷ The penultimate line appears to be unconnected words, and the final line is Le Bé's signature in Hebrew: 'BePariz Gulielmo Lebay Tsarfati asa' or made in Paris by Guillaume Le Bé Frenchman.

A very similar Rashi script is to be seen in an edition of a *Machzor* printed in Mantua in 1557, yet dates of this edition and Le Bé's attribution of 1574 would rule out this as a use of the typeface.⁵⁴⁸ It is possible that Le Bé might have seen this edition and used it as a model. The Mantua edition does not have any extended characters, but the line spacing (leading) is identical. Another Hebrew type which appears in this 1557 Mantua edition is a 3.9 mm Square Sephardic and is used on the title page and on headings, and is very similar to Le Bé's 1548 Hb10(S). It is possible that strikes of this Hebrew were sold to the printers named on the title page, Yaakov ben Naftali Cohen of Gazzuolo (*fl.* 1556-1562) and Meir ben Ephraim Sofer (1556 to 1587).⁵⁴⁹ Le Bé does not mention any transactions of this sort with printers in Mantua, but they could have acquired them from Venetian printers.

⁵⁴⁶ Heller, *The sixteenth century Hebrew book*, pp. 102-103

⁵⁴⁷ See 'Abraham Ben Meir Ibn Ezra' (<<http://www.jewishencyclopedia.com/articles/7985-ibn-ezra-abraham-ben-meir-aben-ezra>> [Accessed 22 July 2011]

⁵⁴⁸ Thomas Frognall Dibdin, *An introduction to the knowledge of rare and valuable editions of the Greek and Latin classics: Together with an account of polyglot Bibles, polyglot psalters, Hebrew Bibles, Greek Bibles and Greek fathers, and the Latin fathers*. 4th ed., greatly enlarged and corrected. ([S.l.]: Harding and Lepard, 1827) Shelfmark 1973e1.

⁵⁴⁹ Ascarelli and Menato, *La tipografia del '500 in Italia*, p. 186

The further two specimens of this typeface appear as headings and signature on Folios 11v and 12v of NAF 4528 and are dated to 1579. They do not present any examples of the swash extended letters, nor does the first printed use as noted by Vervliet: Francesco Giorgio's *Harmonie du Monde*, printed by Jean Macé in Paris in 1579.⁵⁵⁰ The type here is used for occasional Hebrew words without any swash/extended letters, but this edition does show the condensed lamed character, as does the *Psalmus Primus* printed by Guillaume II Le Bé in 1612.⁵⁵¹

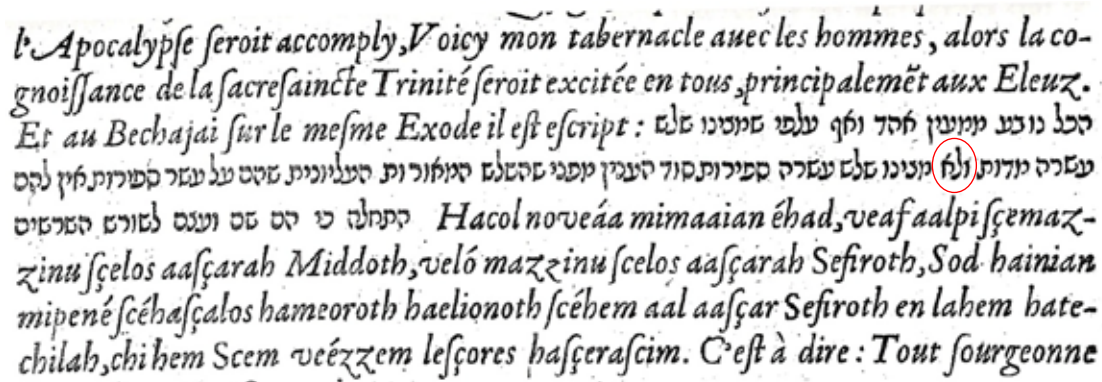

Fig. 3.69: Hb18 (R) Example from *Harmonie du Monde*. Jean Macé, Paris 1579 (BL 692.f.17. from the Epistre section)

The specimens held in the Plantin Moretus archive contain 39 strikes (MA135a). This typeface appears in the inventories of 1590 (Leiden) and 1652. This is described as *Garamonde cursive hebraïque* in the *Inventaris*,⁵⁵² which Vervliet identifies as being Le Bé's Rabbinical Hebrew on English (Hb 2.3) in his *Conspectus*, yet the material in the MPM Inventories is less conclusive and suggests that it could be a Bomberg type.⁵⁵³ The attribution to Le Bé does appear to be correct, given the condensed lamed, and the zayin and yod cast with Gershayim – the double punctuation marks over the character. These can be seen on both the Le Bé specimen and the Plantin Moretus specimen of strikes. What is curious is the smaller nun whose use is not clear. The smaller nun can be seen on lines seven and nine from the top of the Le Bé specimen. None of the extended final characters are included in the strikes. It is very clear that these strikes have *not* been justified, and a close examination shows the distortion to the matrix sides caused by the impact of the punch on the matrix and the unfinished state of the heads of the strikes. Small circular indents have been added to the reverse of each strike to hold the pin in mould.

⁵⁵⁰ Vervliet, *French Renaissance Printing Types: A Conspectus*, p. 398. See also Schwarzfuchs and Coron, *Le livre hébreu à Paris au XVIIe siècle*, p. 202. The date on the title page of the British Library copy reads MDLXXIX or 1579. (Integrated Catalogue number 692f17)

⁵⁵¹ *Psalmus Primus cum Commentarijs*, Paris, Guillaume II Le Bé, 1612

⁵⁵² Plantin-Moretus., *Inventaris van de stempels en matrijzen van het Museum Plantin-Moretus. Inventory of the Plantin-Moretus Museum punches and matrices. Eng.*, p. 116

⁵⁵³ Vervliet, *French Renaissance Printing Types: A Conspectus*, p. 398 and Parker, Melis, and Vervliet, *Typographica Plantiniana II*, pp. 96, 98



Fig. 3.70: MA135a strikes (Museum Plantin-Moretus/Prentenkabinet)

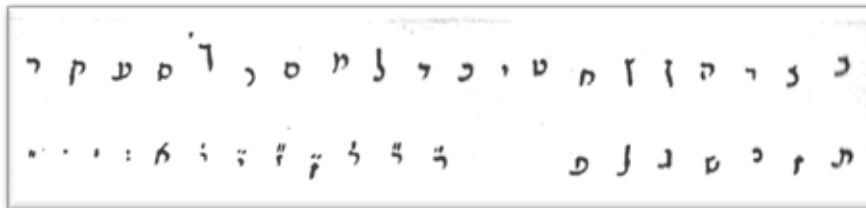

Fig. 3.71: MA135a specimens (Museum Plantin-Moretus/Prentenkabinet)

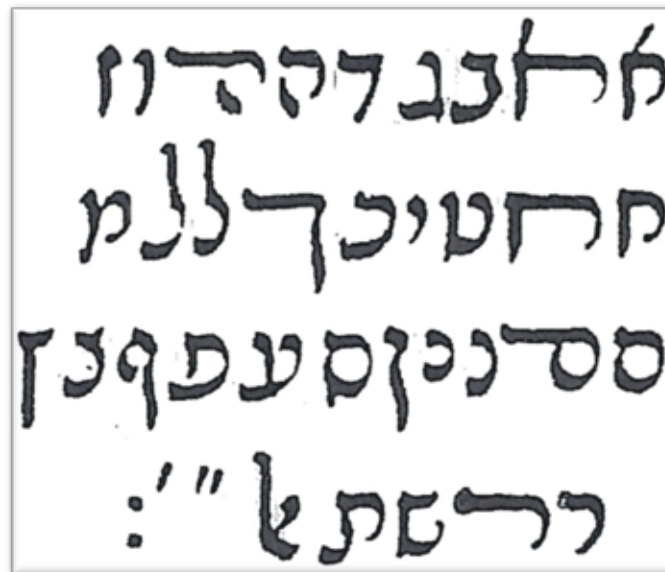

Fig. 3.72: Hb18 (R); Assembled alphabet from the Le Bé specimen enlarged to 10 mm appearing size.



Fig. 3.73: Hb18 (R); Assembled alphabet from then Le Bé specimen at actual size.

This same typeface was later used as a model for a Rashi cut in the nineteenth century and shown in various Imprimerie Nationale publications. The size is larger (3 mm x-height) and subtle changes made to various characters, such as the final mem, the tav, but note the similarities to the tsadde and the lamed. The table below

is from the 1927 publication edited by Charles Fossey and printed at the Imprimerie Nationale.⁵⁵⁴

FIGURES.	NOM.	VALEUR.	FIGURES.	NOM.	VALEUR.
א	'alef	'	ל	lamed	l
ב	bet	b	מ	mem	m
ג	gimel	g (dur)	נ	nun	n
ד	dalet	d	ס	samek	s
ה	hé	h	ע	'aïn	'
ו	waw	u, w	פ	pé	p
ז	zain	z	צ	çadé	ç
ח	het	h	ק	kof	k
ט	tet	t	ר	reś	r
י	yod	i, y	ש	šin, sin	š, s
כ	kaf	k	ת	taw	t

Fig. 3.74: Alphabet Rabbinique from the Imprimerie Nationale (*Notices sur les Caractères Étrangers anciens et modernes*, Fossey, 1927)

Attributions for this typeface in printed editions:

- *Linguae Hebraicae Institutiones Absolutissime*, Paris, Guillaume II Le Bé, 1609

⁵⁵⁴ Charles Fossey, *Notices sur les caractères étrangers anciens et modernes rédigées par un groupe de savants. Réunies par M. C. Fossey* (Paris: Imprimerie Nationale, 1927), p. 78

Hb19 (S)

Appears on NAF 4528 folios 11v and 12v

Size: Petit texte hebreu (Textin), Vervliet = English-sized Hebrew [HB 2] or Saint-Augustin

Type Classification: Square Sephardic unpointed and pointed

Measurements: x-height of 1.9 mm; 10 lines = 42 mm pointed (Vervliet = 2.0 mm and 20:90 pointed)

Date of creation: 1579 in Paris

Punchcutter: Guillaume I Le Bé (his sixteenth numbered)

First use: None

Materials preserved:

Type Specimens: 1599 Le Bé Moretus specimens,

Literature: Vervliet *Conspectus*: 380/Le Bé's English-sized Hebrew [Hb 2] or Saint-Augustin, Le Bé *Inventaire après décès* c. 1617 (Hebreu Saint Augustin mon père) – probable attribution

First Occurrence: *Linguae Hebraicae Institutiones Absolutissime*, Paris, Guillaume II Le Bé, 1609

Le Bé writes in his annotation to NAF 4528 folio 12v that this typeface was cut in Paris, yet the typeset note above the specimen (in Hb18 (R)) has the following text in Hebrew: *El HaElyon Carlo Quirini Atzil Veneziano*. This translates as 'To the most mighty Carlo Querini Venetian Nobleman'. The phrase *El HaElyon* or alternatively *El Elyon* is used in the Bible to refer to God and is used here as a translation of the Italian honorific term *Magnifico*, as was used for example for Lorenzo de' Medici during the Renaissance – Lorenzo the Magnificent or Lorenzo il Magnifico.⁵⁵⁵ It tells us that Le Bé continued to have a connection with Querini after his return to Paris from Venice and yet, Querini only appears to have published Hebrew books during the 1540s in collaboration with Meir di Parenzo. It is not clear why Le Bé would have dedicated this typeface to him. The only likely attributions for this typeface seen to date are the *Linguae Hebraicae Institutiones Absolutissime*, printed by Guillaume II Le Bé in 1609 and the *Glossarium Universale Hebraicum*, printed by the Imprimerie Royale, Paris in 1697.

There is also a possible link to the Cicero Hebrew found in the type specimens of Louis Delacolonge of 1773. Delacolonge's typefoundry was in Lyon and had a good selection of identifiable founts by Claude Garamont, Pierre Haultin, Robert Granjon, Jean Arnould, Jacques I Sanlecque, Francois Gando le Jeune, Claude Lamesle, and Nicolas Gando. The Hebrew founts were not absolutely attributed by Harry Carter in his critical edition of the specimens, but he did note that 'it looks like an old copy of one by Guillaume I Le Bé'. The specimen for the Hébreu ponctué de Cicero adds that he had 'Hébreux au corps de Petit-Texte, de Petit-Romain, de Philosophie, de Cicero, de Saint-Agustin, & de Gros Romain' and that 'les points d'hébreu sont toujours au corps de nonpareille pour tous les corps'. Thus it is quite plausible that Delacolonge had more Le Bé Hebrew founts in his foundry, which he probably acquired when he took over the business in the 1760s. There are some differences in

⁵⁵⁵ The term is also found in the first blessing of the daily Amidah prayer, where the prayer reads 'the Most High God who bestows loving kindnesses'. I am indebted to Rabbi Alex Chapper of the Ilford Federation Synagogue for this reference. See also Gen 14: 18-20.

the characters as compared to the Le Bé original, for example the ayin, which may be a sign of a later recutting.⁵⁵⁶

The text of the specimen in both examples is from Psalms 124, the difference being that the specimen in folio 11v is unpointed whereas the specimen in folio 12v is pointed – both vowels and cantillation marks. There are also examples of *literae dilatables* (aleph, heh and final mem), which indicate that the typeface was intended for a full Biblical setting. Le Bé has as usual added his signature and the date is also typeset in both cases.⁵⁵⁷ The arabesques at the top and bottom of Folio 12v as well as around the date are most probably French, but as yet unidentified.

The annotation in Le Bé-Moretus specimen no. 29 reads ‘Texte hébreu a fondre avec les pointz sur le St. Augustin. Taillé par feu mon pere’.⁵⁵⁸ Le Bé notes that size is ‘nommé a Venise le textin’, and the closest in name is the Italian size Testino or approximately 8 points Anglo-American. This is equivalent to the old English size Brevier or old French petit texte.⁵⁵⁹ The pointed version is indeed very close in x-height and leading to the St. Augustin Roman shown in Vervliet’s *Conspectus*.⁵⁶⁰

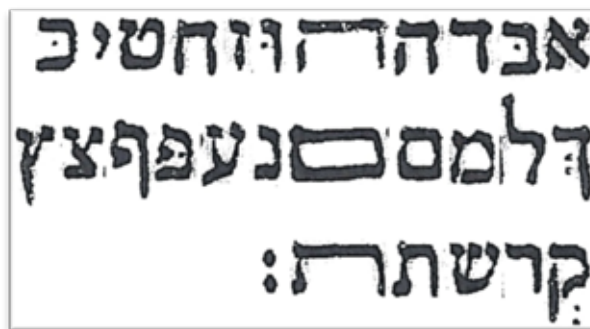

Fig. 3.75: Hb19 (S) Assembled alphabet enlarged to 8 mm appearing size



Fig. 3.76: Hb19 (S) Assembled alphabet at actual size

⁵⁵⁶ Delacolonge and Carter, *The type specimen of Delacolonge*, pp. 22-28, 75-81

⁵⁵⁷ BePariz Gulielmo Lebay Tsarfati asa or Made in Paris by Guillaume Le Bé Frenchman.

⁵⁵⁸ Hebrew text to be cast with points on St. Augustin. Engraved by my late father.

⁵⁵⁹ Bauer, *Handbuch fuer Schriftsetzer ... Dritte neu bearbeitete Auflage, etc.*, pp. 30-31 and Reed and Johnson, *History of the old English Letter Foundries*, p. 32

⁵⁶⁰ See R93 and R95 for example in Vervliet, *French Renaissance Printing Types: A Conspectus*, pp. 166-170



Fig. 3.77: Hb19 (S) Specimens from NAF4528 folios 11v (Left) and 12v (Right) Actual size

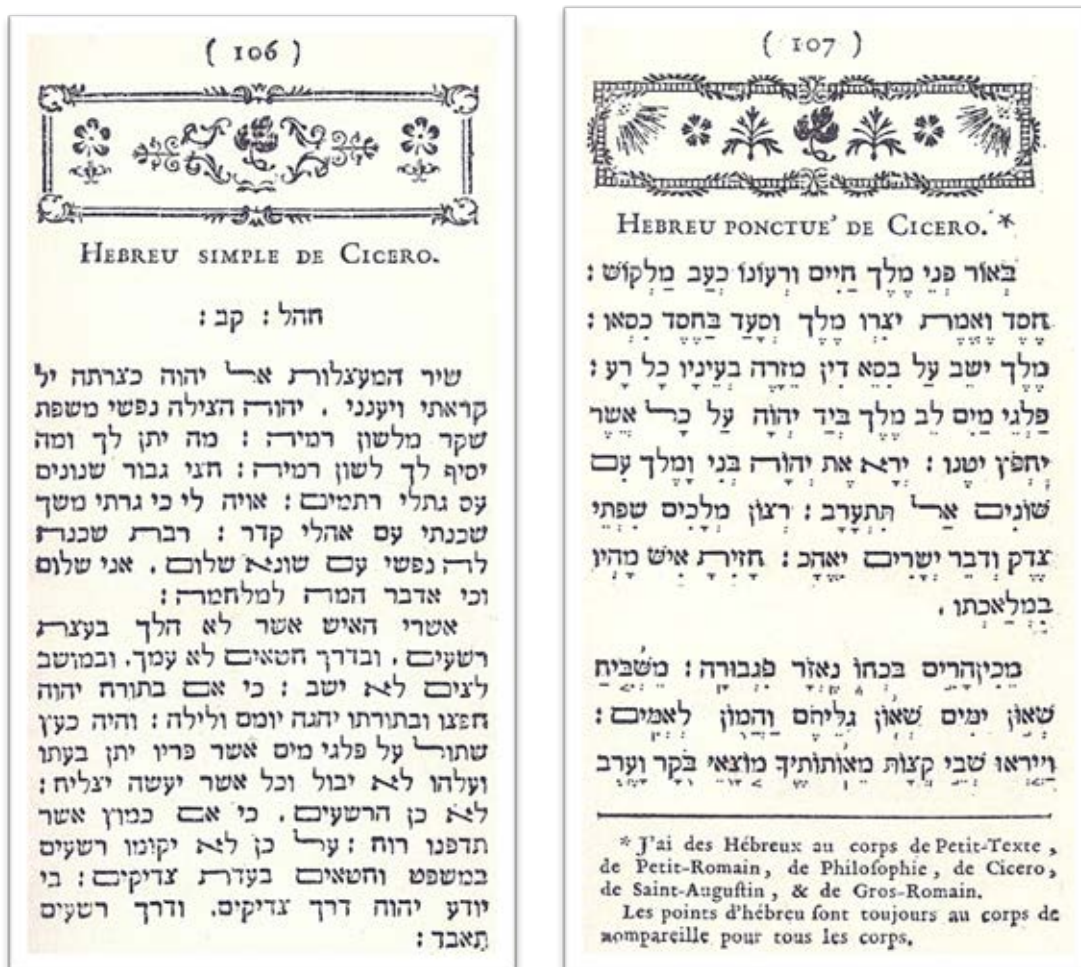

Fig. 3.78: Hb19 (S) Specimens from the Delacolonge specimens of 1773 Actual size

Hb20 (R)

Appears on NAF 4528 folios 16v and 17

Size: Unidentified Vervliet = Le Bé 's Rabbinical Hebrew on eight-line Pica [Hb 17]

Type Classification: Rabbinical (Rashi) unpointed

Measurements: x-height of 17 mm

Date of creation: 1591 in Paris

Punchcutter: Guillaume I Le Bé (unnumbered, but number 19 in this thesis)

First use: No known uses

Materials preserved: None

Type Specimens: NAF 4528 folios 16v and 17 only

Literature: Vervliet *Conspectus*: 405 Le Bé's Rabbinical Hebrew on Eight-line Pica [Hb 17; Omont, *Spécimens de Caractères Hébreux, Grecs, Latins et de Musique*, 1889, No. XVI bis

This alphabet is the nineteenth Hebrew typeface produced by Le Bé, and has no recorded uses, nor any surviving material. They are clearly printed specimens, judging by the ink squash and slightly uneven inking visible on some of the letters. They appear to have been cut by someone else and not to Le Bé's satisfaction, yet there is a suggestion that they were sold in some haste. Le Bé notes that he did not have the energy or time to clean them up.⁵⁶¹ He was 66 at the time and very near the end of his career as a punchcutter.

A further point of interest in this annotation is Le Bé's comment on what he calls 'une lettre courante dont les Hebreux se servent en l'écriture de leurs comptes et affaires ordinaires'. The term 'courant' applies in Latin palaeography to the humanistic cursive book script, which began to appear in the late fourteenth century in Florence.⁵⁶² This cursive humanistique courante was characterised by 'son exécution extrêmement rapide, l'accumulation des ligatures et des abréviations en fin du mot'.⁵⁶³ Le Bé appears to be confusing the Hebrew cursive hand with the Rashi rabbinical hand, which although it did have its roots in the cursive hand, is quite distinct from the everyday cursive script. The cursive script has quite different forms which developed from the need to write quickly and resulted in joined-up letters where necessary. Le Bé writes that the current hand is not so 'fardée et arrondie, mais sent plus sa chicanerie, coppie et courante' (not so 'painterly i.e. calligraphic and rounded) and this is indeed the case if one compares the following examples to the typeface in question. Le Bé did not appear to find the Jewish cursive hand very attractive and is perhaps trying to explain why he never used it as a model. His use of the word 'chicanerie' could be interpreted to express a certain underlying dislike of Jews and their business practices.⁵⁶⁴ This cursive is the antecedent of the model presently used in the Hebrew speaking world and increasingly adapted as an

⁵⁶¹ Cotgrave, *A Dictionarie of the French and English tongues*, pp. (RAB-RAC)

⁵⁶² Michelle Brown, *A guide to western historical scripts from antiquity to 1600* (London: British Library, 1990), pp. 126-135

⁵⁶³ Mediavilla, *Histoire de la calligraphie française*, p. 164

⁵⁶⁴ The *Dictionnaire de l'Académie française*, 1st Edition (1694) defines 'chicane' as 'les subtilitez captieuses dont on se sert dans les disputes de l'escole, & pour les contestations mal fondées que l'on fait, soit dans le jeu, soit en autre chose'. Harry Carter interpreted it as 'cleverness' in an unpublished manuscript.

alternative to the Square Sephardic for signage and display typography. A good example is the version created by Zvi Narkis in 1998 called Narkis Tami.

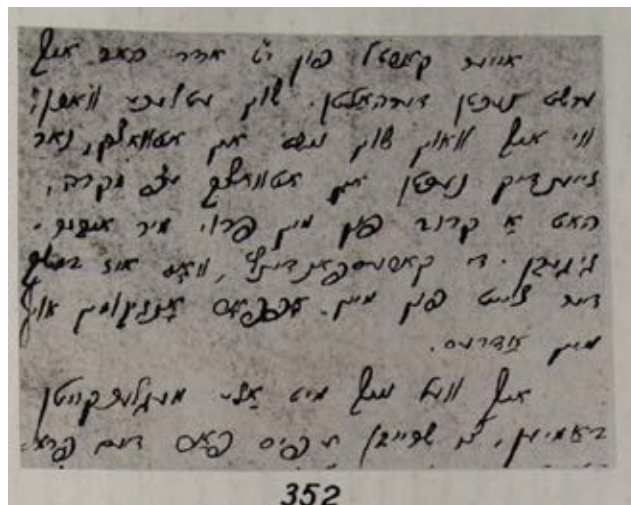

Fig. 3.79: Example of Hebrew cursive script (Yiddish) from Birnbaum, *The Hebrew Scripts*, Vol II.

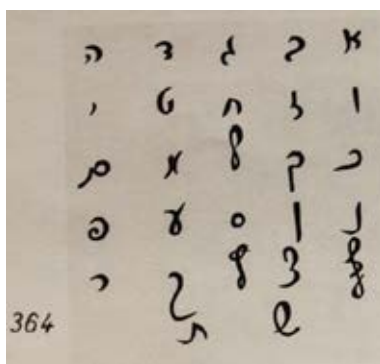

Fig. 3.80: Example of Hebrew cursive script alphabet from Birnbaum, *The Hebrew Scripts*, Vol II.

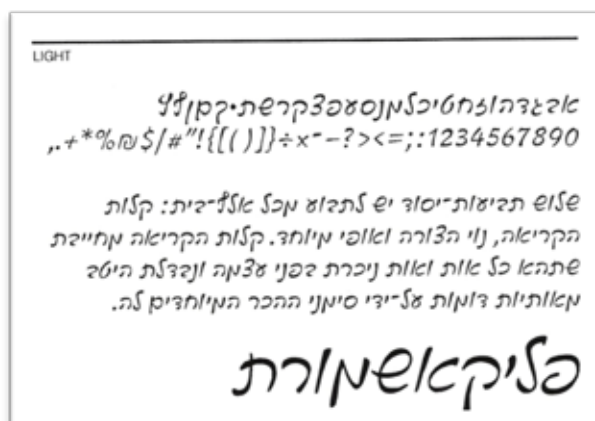

Fig. 3.81: Specimen of Narkis Tami Light (Specimen from Authors' collection)

This Hebrew appears in the *Alphabetum rabbinicum ex antiquiss*, printed by Guillaume II Le Bé in 1600.⁵⁶⁵

⁵⁶⁵ Schwarzfuchs and Coron, *Le livre hébreu à Paris au XVIe siècle*, p. 224



Fig. 3.82: Hb20 (R) Assembled specimen from NAF 4584 F. 16v-17 (Actual size)

Hb21 (S)

Appears on NAF 4528 folios 16v and 17

Size: Not identified, Vervliet = Le Bé's Hebrew on Eight-line Pica [Hb 17]

Type Classification: Square Sephardic unpointed

Measurements: x-height of 17 mm

Date of creation: 1591 in Paris

Punchcutter: Guillaume I Le Bé (unnumbered, but number 20)

First use: No known uses

Materials preserved: None

Type Specimens: NAF 4528 folios 16v and 17

Literature: Vervliet *Conspectus*: 404 Le Bé's Hebrew on Eight-line Pica [Hb 17], Omont *Spécimens de Caractères Hébreux, Grecs, Latins et de Musique*, 1889, No. XVI bis

This typeface may be considered the twentieth and final Hebrew cut by Le Bé. It is not even clear if it was cast in metal or engraved in wood. The specimens are clearly printed and ink squash is visible in some of the characters. Yet the very size of the characters would indicate a wood engraving, as Le Bé does mention in the case of Hb 17 (S), where he used the services of the *Dominotier* Machiel Du Boys for the engraving. It is not improbable that he did the same in case of these two typefaces, but was not pleased by the result: 'ont esté fort mal taillées par un qui n'a observé les traictz ny les corrections, n'ayant a cause du temps meilleur moyen de les fayre, se passerent aussi mal que le temps, et les despescha pour avoir de l'argent pour vivre'.

The trade or craft of *Dominotier* was apparently well-established in Le Bé's native city of Troyes and it is likely that he would have known of them and used their services.⁵⁶⁶ It has been noted that 'les images de dominoterie, dont Troyes et Rouen fournissaient la France et toute l'Europe', involved hand colouring of printed or engraved images.⁵⁶⁷ The series of wood engravings produced by the Le Bé family has been previously discussed.⁵⁶⁸

Harry Carter notes in his edition of Moxon's *Mechanick Exercises* that 'it is unlikely that letters bigger than the Dutch Groote Kanon (about 0.6 in or 15 mm) were cast as type until the middle of the eighteenth century.' As evidence he cites an item from Henri Du Tour's (Hendrik Van den Keere) account book of 1575, which talks about 'la Fonte en Sablon', and a note from Franciscus Raphelengius Junior in 1618 which also speaks of 'wooden punches for the biggest capitals and window-bill letters and all such as they cast in sand'.⁵⁶⁹

Nevertheless without any examples of either actual usage or documentary evidence as to how they were made, this can only be a supposition at present.

⁵⁶⁶ *Le Thresor de la langue francoyse* (1606) defines 'dominotier' as 'celuy qui fait et qui vend des dominos, c'est à dire des images et oeuvres de pourtraicture peintes et imprimées en papier, et gravées en bois ou cuivre', which implies a wide trade than someone who dealt only in marbled papers.

⁵⁶⁷ Louis Morin, 'Un Atelier de Peintres-Dominotiers à Troyes', *Bulletin du Bibliophile et du Bibliothécaire* (1899), pp. 105-106

⁵⁶⁸ See page 143 in this thesis.

⁵⁶⁹ Moxon, Carter, and Davis, *Mechanick Exercises*, p. 371

The main distinctive element in this typeface is the lamed, where the ascender of the lamed bends to the right, with a flag-shaped termination stroke.



Fig. 3.83: Hb21 (S) Assembled specimen from NAF 4584 F. 16v-17 (Actual size)

Hb22 (R)

Appears on NAF 4528 folios 13; and Rés X 1665, folio 5v

Size: Grosse Glose (cast on Gros Romain body)

Type Classification: Rabbinical (Rashi) unpointed

Measurements: x-height of 2.8 mm; 10 lines = 54 mm (Vervliet *Conspectus*: 20:117)

Date of creation: 1592 in Paris

Punchcutter: Guillaume I Le Bé (his seventeenth numbered)

Type Specimens: In Le Bé Moretus specimen: 1599 no. 25,

Literature: Vervliet *Conspectus*: 394/Hb 2.8 Le Bé's Rabbinical Hebrew on Great Primer, Lane, *Early Type Specimen*, 2004, pp. 248-9, no. 158, Le Bé *Inventaire après décès c. 1617* (Glos Hebraïque Gros Romain mon père) – probable attribution

First Occurrence: *Linguae Hebraicae Institutiones Absolutissime*, Paris, Guillaume II Le Bé, 1609

Le Bé dates this specimen to June or July of 1592, *after* the siege of Paris during the period of the Wars of the Three Henris: (1585-93), during which Henri III – then allied with the Calvinist faction – laid siege to Paris. Henri III was assassinated in 1598, and Henri de Navarre, who took the title of Henri IV, eventually declared himself a Catholic and was crowned at Chartres in 1593, and entered Paris unopposed in March 1594.⁵⁷⁰ The siege of Paris lasted from May to September 1590 and was 'l'un des plus atroces épisodes des guerres de Religion'.⁵⁷¹ The diarist Pierre l'Estoile recorded his observations from this period which saw acts of extraordinary cruelty committed by both sides. L'Estoile also records the famine which probably cost the lives of some 30,000 Parisians, out of a total estimated population of some 250,000 to 300,000.⁵⁷² Another chronicler, Henri de Monantheuil, wrote of the siege, that it was a siege 'duquel la memoire ne s'effacera jamais, à cause de l'incoiable famine et disette de toutes choses necessaires a la vie, que tout le peuple y a supporté, de veilles, de soings, de crainte, de tristesse, manquante de toute victuaille necessaire, n'ayant point de gensdarmes pour sa defense ou bien ce peu qu'elle en avoit c'estoient gensdarmes tous alangouris (languishing) de famine et de necessité ...' ⁵⁷³

These events put into context Le Bé's comment that he cut this type 'pour passer l'ennui'.⁵⁷⁴ One can well imagine the effect this situation might have had on a man of his age, and not less so on his various businesses.

⁵⁷⁰ See French Wars of Religion – a quick timeline'. See also Gullemette Payen and Michel De Jaeghere, 'Vive Henri IV!', in *Le Figaro (Hors Série)*, 2010

⁵⁷¹ L'Estoile and Papin, *Paris pendant les guerres de Religion: extraits de ses registres-journaux*, p. 313

⁵⁷² De L'Estoile was an 'audiencier a la chancellerie du Partlement de Paris', or an officer in the Chancery who 'hears examines or hears read all patents before they pass the seale and delivers them out'. See Cotgrave, *A Dictionarie of the French and English tongues*, pp. (Letters AVD-AVE)

⁵⁷³ Guillaume Bishop of Lisieux Du Vair, Jacques Flach, and Frantz Funck-Brentano, *Traité de la constance et consolation es calamitez publiques ... Edité par Jacques Flach ... et F. Funck-Brentano, etc* (Paris: Librairie de la Société de Recueil Sirey, 1915), pp. 15-16

⁵⁷⁴ Cotgrave (1619) defines ennui (ennuy) as 'annoy, vexation, trouble, disquiet, griefe, anguish, wearisomenesse ...' so it is most likely that Le Bé is not referring to his own boredom, rather to the anguish he suffered.

Le Bé also records his age at 68, which could not be correct if he were born in 1525, but rather 1524. The date given in Hebrew in the specimen is the month of Nisan in 1592, which is equivalent to March 1592 and which would thus date the specimen to earlier in the year 1592. Thus whatever the actual date when this typeface was cut, the circumstances must have been difficult. Perhaps due to the very events of the time, it does not appear to have had any distribution at all. Yet the 1730 Inventory does show a set of 43 punches for a 'Glose Hébraïque gros Romain, mon père' and set of 44 matrices for a 'Glose hebraïque G. Romain mon père', so it is more than likely that this typeface remained in the Le Bé family until the sale of the foundry in the eighteenth century. Yet the number of characters taken from the specimen is 35, which leaves another four unaccounted for, as the specimen does not contain the characters tet, ayin, Final peh and final Tsadde.

An intriguing and as yet unattributed specimen of this typeface appears in the specimen book of the Fonderie Générale of Adolphe René, in Paris, 1858. The Rabbinique du Treize is an exact copy of Hb19 (S) including the same text as used in the specimen of Hb18 (R).⁵⁷⁵



Fig. 3.84: Hb22 (R). The full specimen (NAF 4528 f. 13) Actual size

⁵⁷⁵ See page 198 of this thesis for earlier discussion of this specimen.

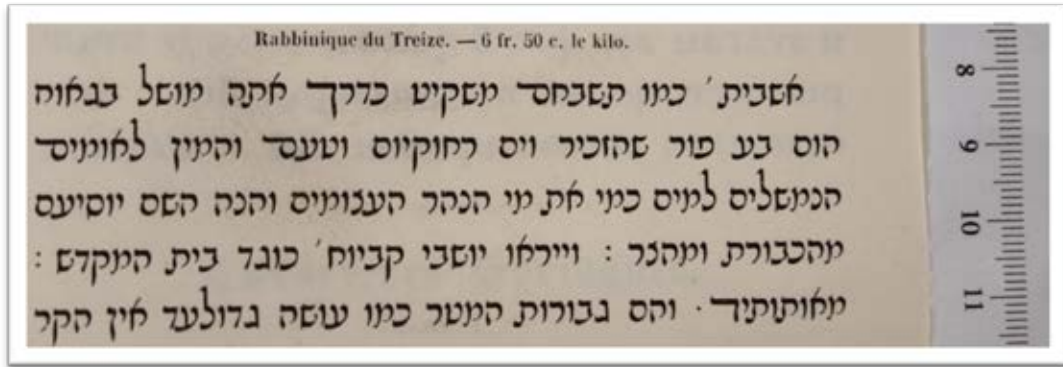

Fig. 3.85: The Rabbinique du Treize from the Fonderie Adolphe René, 1855 (Actual size)

Just as Le Bé appears to have used a Sephardic model for Hb18 (R), this typeface shows influences from the same source. The small ‘superscript’ nun in line ten from the top in the specimen is also found in an edition from the press of Samuel d’Ortas in Leiria, Portugal in 1495.⁵⁷⁶ There are also smaller forms of the final mem and the shin, whose origins may well be from scribal forms in Sephardic manuscripts.⁵⁷⁷ The close setting of groups of characters point to sophisticated composition and kerning techniques at this early stage of Hebrew type casting.

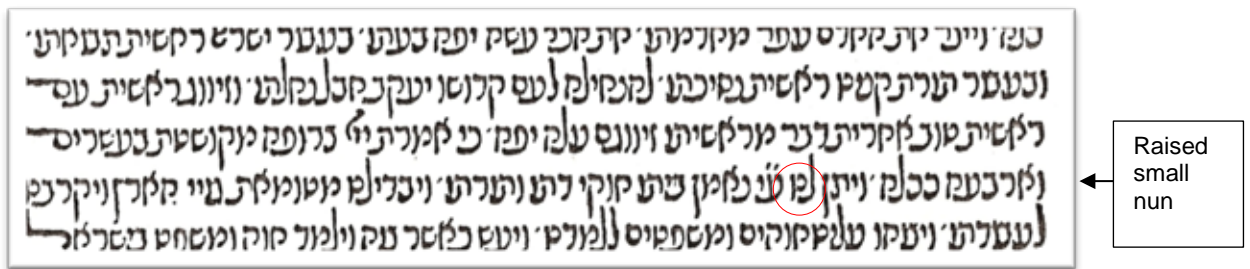

Fig. 3.86: Jacob ben Asher’s *Tur Orach Chayim*. Printed by Abraham d’Ortas in Leiria, 1495. (From Freimann, *Thesaurus typographiae Hebraicae saeculi XV*, Plate B29.2)

The specimen itself is a commentary in Zechariah 14 by the twelfth-century Biblical commentator David Kimchi, also known as Redak.⁵⁷⁸ The final line contains Le Bé’s usual signature plus the date: *BePariz Gulielmo Lebay Tsarfati asa beHodesh Nisan beShnat 1592*.⁵⁷⁹ We may imagine that he was able to find a person knowledgeable enough in Hebrew grammar to provide him with the name of the month in Hebrew.

The arabesque at the top of the specimen is very similar to one which is to be seen in Plantin’s *Index Characterum* of 1567, Junta in Venice in 1572, and the Egenolff specimen in Frankfurt of 1592 in the sixteenth century.⁵⁸⁰ This fleuron is attributed

⁵⁷⁶ Freimann and Marx, *Thesaurus typographiae Hebraicae saeculi XV*, pp. [plate B29, 22]

⁵⁷⁷ See assembled alphabets 311- 315 in Volume II of Birnbaum, *The Hebrew scripts* for example of similar scribal hands.

⁵⁷⁸ See article on David Kimchi in Adler, *The Jewish Encyclopedia*.

⁵⁷⁹ Guillaume Le Bé Frenchman made this in Paris in the month of Nisan in the year ..

⁵⁸⁰ Francis Meynell and Stanley Morison, 'Printer's Flowers and Arabesques', in *Fleurion anthology. Chosen and with a retrospectus by Francis Meynell and Herbert Simon*, ed. by Francis Meynell and Herbert Simon (Tonbridge, Kent and London, Toronto and Buffalo: Ernest Benn and University of Toronto Press, 1973), p. 28

to Granjon and was purchased by Plantin from Granjon in 1566.⁵⁸¹ There are matrices listed for 18 fleurons cut by Granjon in the 1730 inventory, which may well have included this particular one.⁵⁸²

This particular typeface has several distinctive elements: the swash final mem (ם), the swash heh, the narrow form of the lamed, the 'superscript' nun, the long ascender to the final nun, and the long descender to the final tsadde. Were it possible to locate further printed examples of this typeface, no doubt the four missing characters could extend this list.

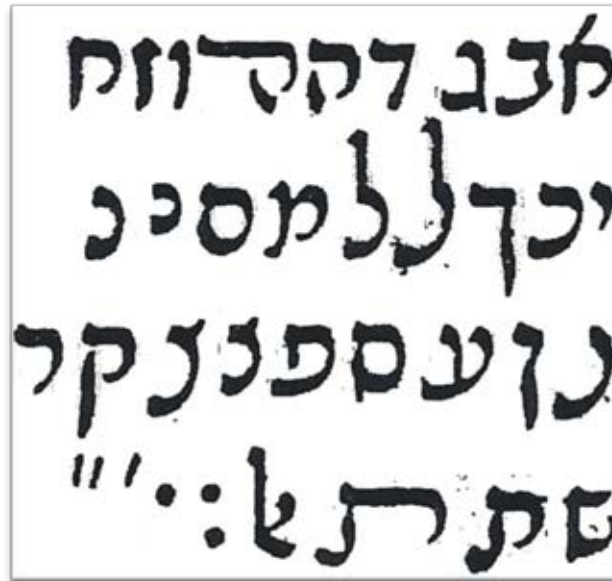

Fig. 3.87: Hb22 (R) Assembled alphabet from NAF 4528 folio 13. Enlarged to 10 mm appearing size.

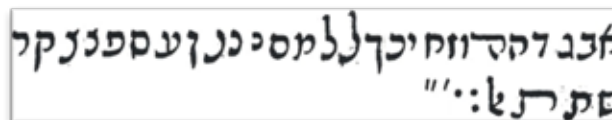

Fig. 3.88: Hb22 (R) Assembled alphabet from NAF 4528 folio 13. (Actual size)

Attributions for this typeface in printed editions:

- *Linguae Hebraicae Institutiones Absolutissime*, Paris, Guillaume II Le Bé, 1609
- Philippe d'Aquin, *Dictionarium absolutissimum*, Paris, Antoine Vitré, 1629

⁵⁸¹ See Dreyfus *et al.*, *Type specimen facsimiles 1-15*, p. 5 and Vervliet, *French Renaissance Printing Types: A Conspectus*, pp. 43-44

⁵⁸² Fournier and Morison, *L'Inventaire de la Fonderie Le Bé*, p. 26

Chapter 4: Analysis of Res X 1665 – Types by other punchcutters

The purpose of this chapter is to analyse the Hebrew types from the second document in the BnF in Paris: Inv. Réserve X 1665. As noted in Chapter One, this is not a chronological listing of types cut by Le Bé, although it does contain seven specimens repeated from Fr. Nouv. Acq. 4528. The balance of the specimens consists of types from the presses of Robert Estienne, Daniel Bomberg, Martin Le Jeune and other unidentified presses of the sixteenth century. It has no specimens of Latin, Greek or Music types, and only presents specimens of Hebrew.

As this document has no handwritten inscription to identify it by Le Bé, as does Fr. Nouv. Acq. 4528, it seems a safe assumption that it was produced after the first, yet it appears to have entered the Royal Library by at least 1750.⁵⁸³ The hand writing used for the annotations is consistent with the hand writing in Fr. Nouv. Acq. 4528. It was probably also bound by this time, given that there are four inserts that are bound into the spine. The sewn binding was also clearly done after the actual compilation, as the binder has trimmed the pages, as can be seen by the cropped annotations on folios three and four at the head. It is also curious that there are seven ‘repeats’ of specimens from the earlier document, often with different annotations. Was this a case of forgetfulness or perhaps that Le Bé did not have the first document in his possession when he compiled the second? There are no obvious answers to these questions.

A working hypothesis is that Le Bé kept these documents as a kind of aide-mémoire for himself of the work he had produced, perhaps as way of asserting ownership of a valuable economic asset. It was also a record of those Hebrew types which he had collected over his lifetime in both Venice and Paris. If this is correct, it adds to their importance for the typographic history of the sixteenth century.

⁵⁸³ See page 16 in this thesis.

Hb23 (S)

Appears on: Rés-X-1665, Folio 1v
Size: Bu Boy's two-line Great Primer Hebrew [Hb 6] or Tresmégiste (Grosse Lettre)
Type Classification: Square Sephardic partially pointed
Measurements: x-height of 5.5 mm
Date of creation: 1545? In Venice
Punchcutter: Michel du Boys for Marco Antonio Giustiniani, and Guillaume Le Bé
First use: Seder tefilot mi-kol ha-shanah, Venice, 1545
Materials preserved: None
Type Specimens: Omont, 887, 263
Literature: Vervliet *Conspectus*, 2010, No. 400, p. 417

In his annotation, Le Bé attributes for this type face to the punchcutter Michel Du Boys, who cut it for Marco Antonio Giustiniani. Le Bé also adds that 'Me (Messer) Leon, Juif, me voulut fayre refayre'. This is no doubt the same messer Leon mentioned in the annotation for 4528, Folio 1, who was Giustiniani's 'prote', i.e. his print shop manager and the person responsible for his Hebrew editions.⁵⁸⁴ In this case, it may be that Messer Leon was not entirely happy with the quality of the type and asked Le Bé to redo it. The final nun and the lamed could be said to show the hand of Le Bé, but the general style is much 'squarer' and less calligraphic than that of Le Bé.

Vervliet attributes five Hebrews to Du Boys in the *Conspectus*, four of them conjectural, whereas this typeface appears to be a solid attribution, given Le Bé's annotation. If one compares this typeface to Du Boy's Great Primer Hebrew, there is indeed a resemblance. Du Boys is known to have been in Venice and Lyons during the 1540s, before going to Geneva, where he died in 1561.⁵⁸⁵

The characteristics of this typeface make it quite readily recognisable. The shin has a very thin middle stroke, the lamed a very distinct flagged termination and the peh a square top stroke and slightly angled termination tip. The type, given its size, was more useful as a display type and thus the dagesh points in the specimen do not seem to have been used. The specimen itself is a conflation of Biblical names – Avraham/Yitzhak/Gad/Ya'akov/Moshe/Aharon/David/Schlomo, followed by four nonsense words, and finally two lines of characters in a semblance of alphabetical order. The purpose of the specimen is to provide a complete sampling of all the characters.

⁵⁸⁴ Omont, *Specimens de caractères hébreux, grecs, latins, et de musique gravés à Vénise et à Paris par Guillaume le Bé, 1545-1592*, p. 8 (N. 1). Dictionnaire de l'Académie française, (1762) Terme d'Imprimerie. 'On appelle ainsi Celui qui, sous les ordres du maître, est chargé de la direction & de la conduite de tous les ouvrages, & de revoir & corriger les épreuves'.

⁵⁸⁵ Vervliet, *French Renaissance Printing Types: A Conspectus*, pp. 40-41, 408



Fig. 4.1: Hb23 (S) Assembled alphabet actual size

The interesting point here is that a set of matrices made their way to Basle, where they were used by Konrad Waldkirch in a series of Hebrew editions. This was probably via the Jewish printer Israel ben Daniel Zifroni, 'who had worked previously for Vincenzo Conti in Cremona and Sabbioneta and would work afterwards for the Di Gara press in Venice'. In Basle Zifroni worked for Ambrosius Froben and upon his return to Italy in 1585 'left a number of books which were ready for printing and which were later printed by Konrad Waldkirch'.⁵⁸⁶



Fig. 4.2: Hb23 (S) from the title page of *Sefer HaShorashim*, printed by Marco Antonio Giustiniani, Venice, 1546, Actual size (UCL Special Collections, SR Mocatta Quarto 1546 K4/1-2)

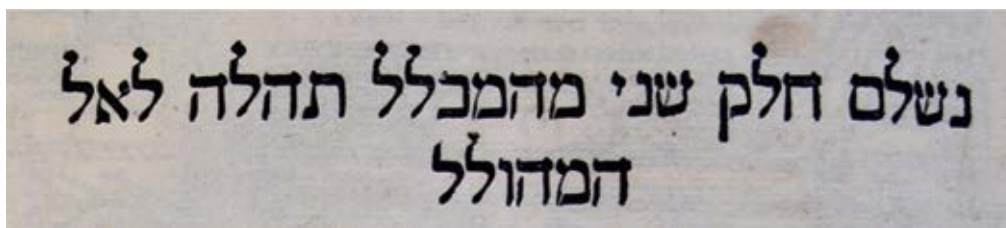

Fig. 4.3: Hb23 (S) from *Sefer HaShorashim*, printed by Marco Antonio Giustiniani, Venice, 1546, (UCL Special Collections, SR Mocatta Quarto 1546 K4/1-2)

Attributions for this typeface in printed editions:

- *Seder tefilot mi-kol ha-shanah*, Venice, 1545
- *Otiot shel Rabi Akiba*, Venice, Giustiniani, 1546
- *Sha'ar bet H. he-hadash: ... Humash im Targum va-Hamesh megilot ve-Haftarot*, Venice, Giustiniani, 1546
- *Sefer Agur*, Venice, Giustiniani, 1546-7
- *Babylonian Talmud*, Venice, Giustiniani, 1546-50
- *Sefer HaShorashim*, Venice, Giustiniani, 1547
- *Halakhot Gedolot*, Venice, Giustiniani, 1548
- *Shulhan Arukh*, Venice, di Cavalli, 1567
- *Seder HaTefilot*, Basle, Waldkirch, 1598

⁵⁸⁶ Heller, 'Ambrosius Froben, Israel Zifroni and Hebrew Printing in Freiburg im Breisgau', p. 3

- *Birkat HaMazon*, Basle, Waldkirch, 1598-99
- *Pithu Sha'arim*, Basle, Waldkirch, 1599
- *Sha'arei Dura*, Basle, Waldkirch, 1599
- *Selihot*, Basle, Waldkirch, 1600
- Moshe de Léon, *Zot HaSefer HaNefesh HaHochma*, Basle, Waldkirch, 1608

Hb24 (S)

Appears on: Rés-X-1665, folios 2, 7, 7v, 8v, 9, 9v, 11, 12v, and 17

Size: Double Augustine (Grosse lettre)

Type Classification: Square Sephardic unpointed

Measurements: x-height of 5.5 mm

Date of creation: 1545 In Venice?

Punchcutter: Jacob of Mantova in Venice (Matrices Justified by Guillaume Le Bé)

Materials preserved: MPM MA34

Type Specimens: Plantin's *Index Characterum* 1567, f. A2, c. 1585 Folio Specimen

Literature: REJ 16:308; Omont p. 7, Parker, Melis, Vervliet, *Typographica Plantiniana* II, p. 43;

Inventaris van de stempels en matrijzen van het Museum Plantin-Moretus, 1960, 193

First occurrence: *Introductio utilissima hebraice discere cupientibus*, Aldus Manutius the elder, Venice, 1500?, *Teshuvot*, Venice, Bomberg 1519

Le Bé's annotation helps us to place this much used and much travelled typeface in a context prior to its acquisition by Christophe Plantin. We do not know precisely who 'Jacob de mantoue' was, but Le Bé tells us that he was a 'jeune homme travaillant a l'imprimerie' and that he sold strikes of this typeface to Meir di Parenzo (Mazo di Parenza), who then asked Le Bé to justify the strikes. If we accept that 'Jacob de mantoue' was a contemporary of Le Bé, it does not resolve the question of why this typeface appears much earlier in a Bomberg edition of 1519. Le Bé's description of him as 'jeune' in the 1540s would therefore disqualify him for being the punchcutter for the Bomberg types. There is indeed a connection between Meir di Parenzo and Bomberg, as Parenzo is said to have 'learned his craft in the shop of the prince of printers Daniel Bomberg, where he was associated with Cornelio Adelkind'.⁵⁸⁷ Thus Le Bé's attribution of this typeface to 'Jacob de mantoue' appears dubious.

The link to Bomberg is confirmed by the fact that this typeface came to the *Officina Plantiniana* by virtue of the 1563 agreement of November 1563, which established a 'compagnie d'imprimerie', of whom the signatories were Charles and Cornille van Bomberghen, Jacques de Scotti, Johannes Goropius Becanus and Cretofre (Christophe) Plantin. This company re-established Plantin in Antwerp and gave him the use of some of the Bomberg Hebrews, but the conditions specified that the Hebrew editions 'simprimeront au nom des Bomberghes sans contrediction quelconque'. The contract also stated that the Hebrew matrices should be returned to the Bomberg family and not kept by Plantin. The Charles and Cornille mentioned in the contract were most probably the son and nephew of Daniel van Bomberghen who had inherited the Venice press and its material in 1556 and who had brought to Antwerp at least 'une partie ... des caractères hébraïques, que Daniel avait fait fondre ou ciseler a grand frais pour usage'.⁵⁸⁸

⁵⁸⁷ Amram, *The makers of Hebrew books in Italy*, p. 367

⁵⁸⁸ See Fernand van Ortroy, 'Contribution à l'histoire des imprimeurs et des libraires belges établis à l'étranger', *Revue des Bibliothèques* (1927), p. 103 and Henri van Bomberghen, *Généalogie de la famille van Bomberghen* (Bruxelles, 1914), pp. 139-143. See also Bruce Nielsen, 'Daniel van Bomberghen, a Bookman of Two Worlds', in *The Hebrew book in early modern Italy*, ed. by Joseph Hacker and Adam Shear (Philadelphia, Pa.: University of Pennsylvania Press, 2011), pp. 67-75

The 45 matrices of MA34 in the MPM archives appear in the Plantin inventory of 1572, but they were acquired before this date, as there is note in the archives which records that in 1564 the punchcutter François Guyot was paid 'for striking and justifying 55 matrices for a Hebrew on 2 règles Augustine including 10 matrices for points which seem to have been lost'. If these matrices were indeed Hb24 (S), no punches has survived from which he could have made strikes.⁵⁸⁹ The dagesh points appear to have drilled into the matrices and not struck, and there are no vowels. Also to be noted is the crude finishing of the head of the matrix, although they appear to be correctly justified. These matrices were listed once again in the 1652 inventory as '47 Dobbel Augustijn Hebreusche'.⁵⁹⁰



Fig. 4.4: MA 34 Matrices Actual size (Museum Plantin-Moretus/Prentenkabinet)

⁵⁸⁹ Parker, Melis, and Vervliet, *Typographica Plantiniana II*, p. 43

⁵⁹⁰ There are at least six Bomberg Hebrews in the MPM archives: MA24 (Petit texte hebreu), MA34 (Double Augustine hebreu), MA 82c (Petite Augustine Hébreu Cursive), MA135b (Mediane cursive Hebraïque), MA135c (Garamonde cursive Hebraïque), and MA167a (Vrai texte Hebreu). See *ibid.* for more details.

A microscopic examination of six of the matrices from MA34 confirms Fred Smeijer's hypothesis that his procedures 2 and 3 would have been used to produce these matrices.⁵⁹¹

The dagesh points in the three characters below were added after the initial strike was produced. The bet, for example, shows three successive holes, possibly produced with some type of circular punch and then finished with a pump drill or hand file. The dagesh in the shin is very roughly struck and show clear signs of the hole being completed with a file. The printing surfaces of the samekh and the ayin also show evidence of being finished by hand. There is no evidence of the use of counter punches to form the counters.

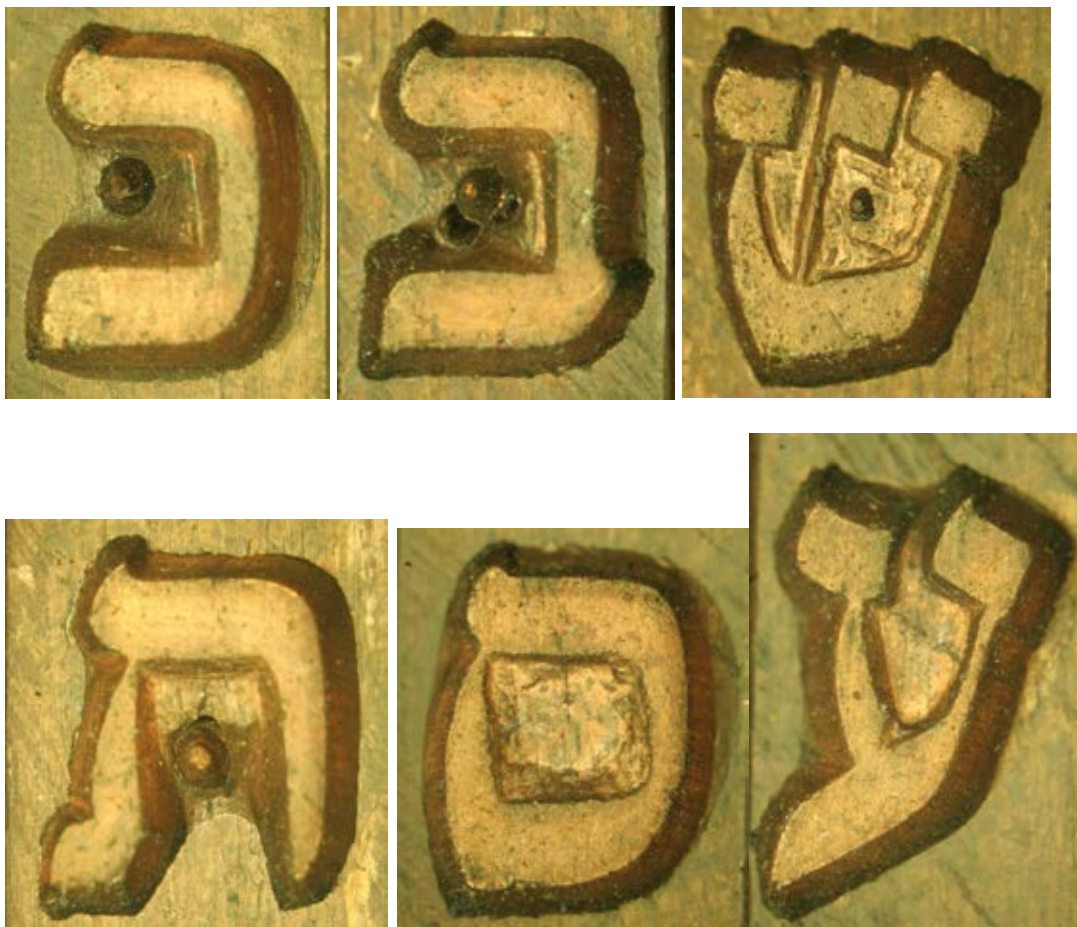

Fig. 4.5: Microscopic examination of the matrices for kapf, bet, shin, tav, samekh and ayin from MA 34. Photographs by Fred Smeijers and Museum Plantin-Moretus/Prentenkabinet (Enlarged 800 per cent)

⁵⁹¹ See page 188 of this thesis.

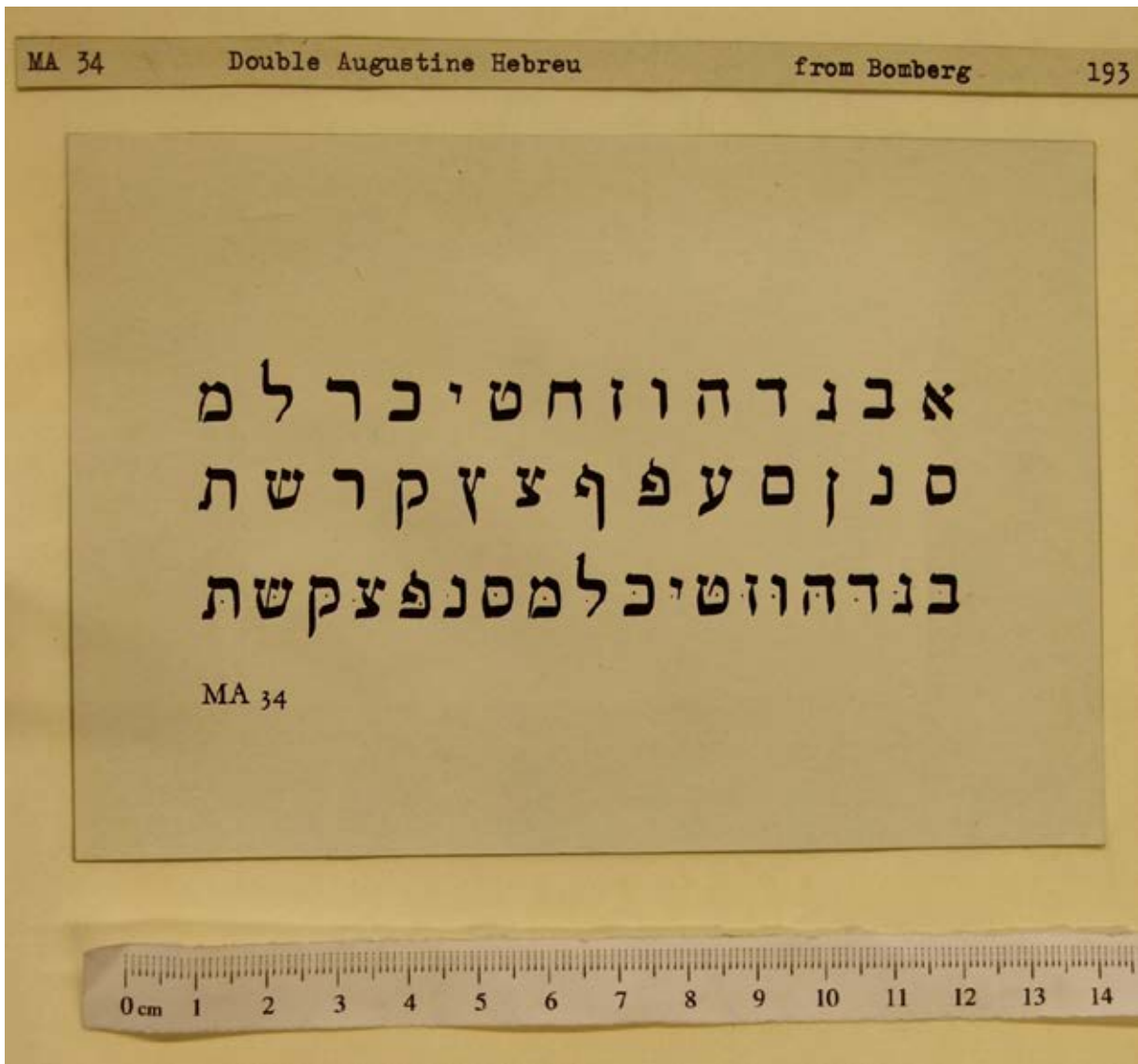

Fig. 4.6: MA34 (Inventaris matrijzen I and II) Actual size (Museum Plantin-Moretus/Prentenkabinet)

A recent study established that there were two distinct display types used by Bomberg, types D and E, and identified type E as the Double Augustine Hebreu of Plantin.⁵⁹² This is the same typeface that was used in the 1523 Bomberg edition of *Mikneh Avram/Peculium Abram*.

⁵⁹² Ruth Kalman, 'The Bookcraft of Daniel Bomberg's Press in Venice in the first Half of the 16th Century (In Hebrew)', Hebrew University of Jerusalem, 1992), pp. 101-103

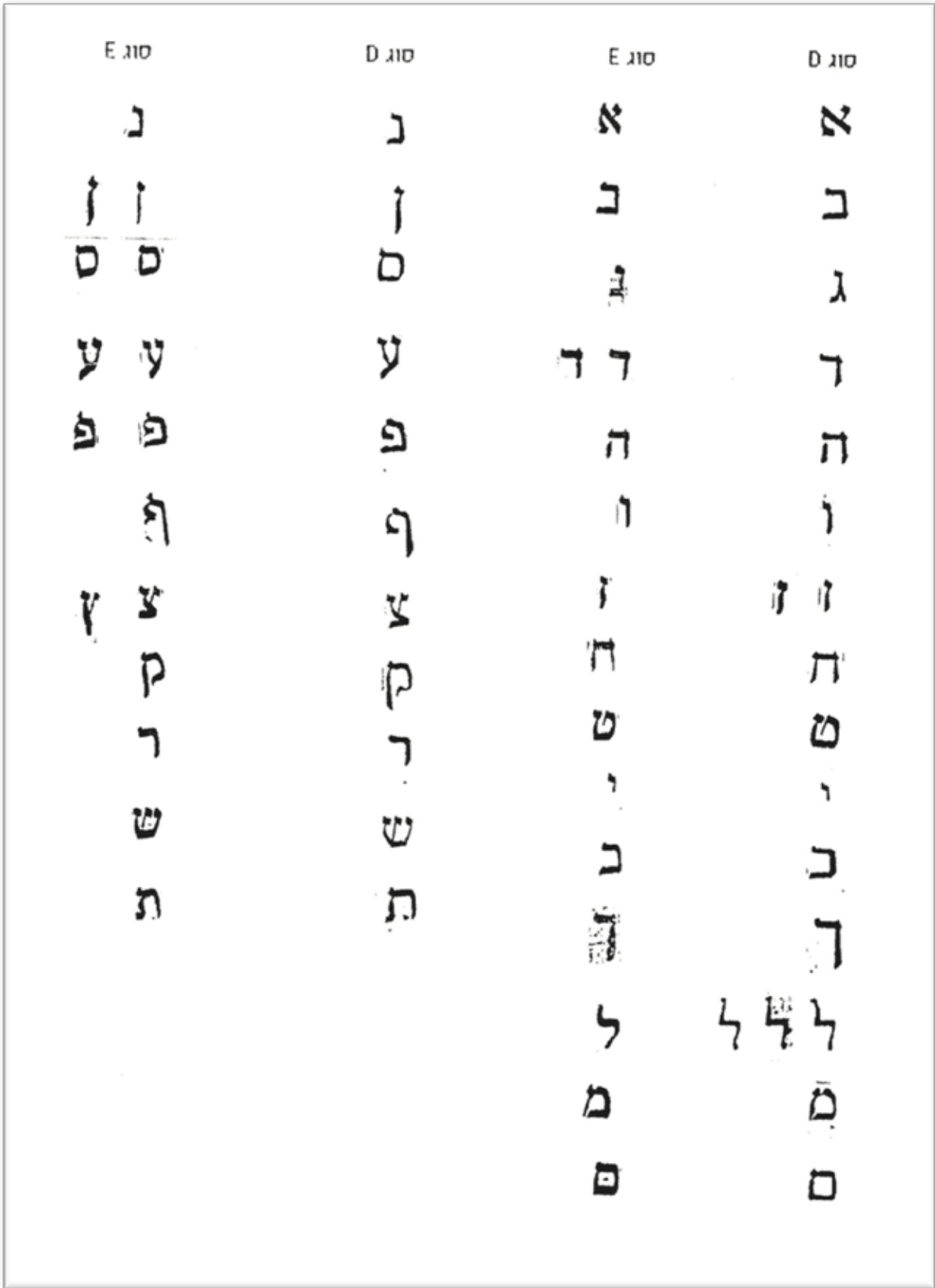

Fig. 4.7: Types D and E display types as used by Bomberg. From Kalman, *The Book craft of Daniel Bomberg's Press in Venice in the first Half of the 16th Century*, 1992, p. 103



Fig. 4.8: Hb24 (S) Assembled alphabet from specimen (Actual size)

Le Bé's attribution of this typeface to the unknown 'Jacob de mantoue' provides a clue to the type of anonymous punchcutters of Hebrew types who would have been active in the sixteenth century. The fact that it was used by such a wide variety of printers says something about its robust qualities as a display type. It is to be seen for example in a 1580 edition of the *Sefer Yuchasin* (Book of Genealogies) printed by Isaac Prostitz in Cracow in 1580. There are differences in certain of the characters such as the lamed, which could indicate a recutting at some point.⁵⁹³

This typeface is also almost identical in detail to the Hebrew that appeared in the *Introductio utilissima hebraice discere cupientibus*, printed by Aldus Manutius the elder in Venice in 1500. The similarity of so many features raises the question whether the same 'Jacob de mantoue' could also be the punchcutter of this typeface. There is also a possibility that it was cut by the punchcutter Francesco da Bologna, also known as Griffio, who was responsible for 'all the types that Aldus ever printed with'.⁵⁹⁴ Francesco da Bologna was at the root of the dispute between Gershom Soncino and Aldus Manuzio, which resulted in Soncino's departure from printing activities in Venice.

The specimen itself is a mixture of possible Talmudic text with errors and invented words to demonstrate the final characters.⁵⁹⁵

⁵⁹³ Kestenbaum & Company, 'Fine Judaica: Printed Books, Manuscripts, Autograph Letters, Graphic & Ceremonial Art To Be Auctioned On Thursday, January 31st', ed. by Kestenbaum & Company (New York: Kestenbaum & Company, 2013)

⁵⁹⁴ Davies, *Aldus Manutius: printer and publisher of Renaissance Venice*, p. 55. See also Mardersteig, 'Aldo Manuzio e i caratteri di Francesco Griffio da Bologna', in *Studi di bibliografia e di storia in onore di Tammaro de Marinis. Verona 1964.* (Verona, 1964), p. 70, University of California - Los Angeles Library, *The Aldine Press: catalogue of the Ahmanson-Murphy collection of books by or relating to the press in the Library of the University of California, Los Angeles: incorporating works recorded elsewhere* (Berkeley: University of California Press, 2001), and Susy Marcon, Marino Zorzi, and Biblioteca Nazionale Marciana., *Aldo Manuzio e l'ambiente veneziano, 1494-1515.* 1a (Venezia: Il Cardo, 1994)

⁵⁹⁵ I am grateful to Dr. Jeremy Schonfield for his comments on this text.



Fig. 4.9: Assembled alphabet from *Introductio utilissima hebraice discere cupientibus*, Aldus Manutius, 1500

ספר יוחסין

לעבר הרי יצחק אביך ועבר את השנה כארץ שנאמר וירא אלקים אל יעקב עוד למה עוד שפעם ראשונה נגלה עליו ומנעו מלעבר את השנה בחוצה לארץ וכשבא לארץ אמר לו הקב"ה קום עבר את השנה ועל שנכנס בסוד העבור ברכו ברכת עולם. יעקב מסרו ליוסף ואחיו והיו מעבדים את השנה בארץ מצרים. מת יוסף ואחיו נתמעטו העבדים וכך עתידים להתמעט בסוף מלכות רביעית. וכשם שנגלה הקב"ה על משה ואהרן כך עתיד להגלות על מלך המשיח: במדרש אסתר דף ל"ז ע"ד. רבי ברכיה פתח מי פעל ועשה קורא הדורות מראש וגומ' מתחילת ברייתו של עולם התקין הקב"ה לכל אחד ואחד מה שראוי לו. אדם ראש ליצורים. קין ראש להורגים הכל ראש להרגים. נח ראש לנמלשים. אברהם ראש למולים וכו'.

שת דור שני. ק"ל ליצירה. ויחי שת חמש שנים ומאת שנה ויולד את אנוש. ושני חייו של שת התקבל שנה. ומת שת ונקבר שנת אלף לב ליצירה: ילקוט פרשת בראשית מפרקי רבי אליעזר משת עלו ונתייחסו כל הדורות של צדיקים וכו'.

אנוש דור שלישי. ר"ה ליצירה. ויחי אנוש תשעים שנה ויולד את קינן וכל ימיו של אנוש תתק"ה שנה. ונקב' שנת אלף קמ ליצירה. דור רביעי. ש"ה ליצירה. ויחי קינן שבעים שנה ויולד ארת מהללאל: וכל ימיו של קינן תתק"ס שנה. ונקבר שנת אלף מאתים ושלשים וחמשה ליצירה:

קינן דור חמישי. ש"ה ליצירה. ויחי מהללאל חמש שנים וששים שנה ויולד את ירד. וכל ימיו של מהללאל תתצ"ה שנה. ונקבר שנת אלף לצ ליצירה:

מהללאל דור ששי. ת"ס ליצירה. ויחי ירד שנים וששים ומאת שנה ויולד את חנוך. וכל ימיו של ירד תתקס"ב שנה. ונקבר שנת אלף תלב ליצירה:

ירד נשלים תקלב הראשון שבו משלימים חמנה ולבנה מהלכתן ומתחילי' מהלכתן בנקודה אחת:

חנוך דור שביעי. תרל"ב ליצירה. ויחי חנוך חמש וששים שנה ויולד את מתושלח ויתהלך חנוך את האלקים וגו'. וכל שני חייו של חנוך ש"ה שנה. ואינו כולקח אותו אלקים שנת תתקפ"ו ליצירה: עיין באותיות רבי עקיבא דף ט' ובספרי קבלה תמצא שחנוך בן ירד הוא מטטרון ומעיד שהשם יתברך ראשון ואחרון ומבלעדיו אין אלקים וכו'. ובבראשית רבה פרק כ"ה אמר רבי איבו חנוך חנה היה פעמים צדיק פעמים רשע. אמר הקב"ה עוד שתוא צדיק אסלקנה:

מתושלח

Hb35 (S)

Hb24 (S)

Note the amended terminal to the lamed (i)

Fig. 4.10: Hb24 (S) as used in the *Sefer Yuchasin*, Prostitz, Cracow, 1580. Actual size (From Hebrewbooks.org (The Chaim Elozor Reich / Renaissance Hebraica Collection))

Attributions for this typeface in printed editions:

- *Introductio utilissima hebraice discere cupientibus*, Aldus Manutius the elder, Venice, 1500?
- *Tanach*, Pesaro, Soncino, 1511-1517

- *Teshuvot*, Venice, Bomberg 1519
- *Talmud*, Venice, Bomberg, 1520-23
- *Babylonian Talmud*, Venice, Bomberg, 1520
- *Peculium Abrae*, Venice, Bomberg, 1523
- *Pentateuch*, Venice, Bomberg, 1525-33
- *Voarchadumia*, Venice, Giovanni Tacuino, 1530
- *Bible*, Venice, Bomberg, 1544
- *Midrash Rabot*, Venice, Giustiniani, 1545
- *Sefer Michlol*, Venice, Bomberg and Adelkind, 1545
- *Even Bohan*, Venice, Adelkind, 1546
- *Rabbenu Bahya*, Venice, Bomberg, 1546
- *Pesikta Zutarta*, Venice, Bomberg, 1546
- *Rabbi Levi ben Gershom*, Venice, Bomberg, 1547
- *Sefer Birkat Avraham*, Venice, Bragadin, 1552
- *Sefer HaKuzari*, Venice, Parenzo, 1547
- *Sefer Sha'ar Hashamayin*, Venice, Parenzo, 1547
- *Sefer Sha'arei Dura*, Venice, Parenzo, 1547
- *Mishnayot MiSeder Nashim*, Venice, Querini, 1548
- *Mikraot Gedolot*, Venice, Bomberg, 1548
- *Sefer Mashal HaKadmoni*, Venice, Parenzo, 1550?
- *Mishneh Torah*, Venice, Giustiniani, 1550
- *Mishneh Torah*, Venice, Bragadin, 1550
- *Sefer Hazut Kashah*, Sabionetta, Foa, 1552
- *Grammatica Hebraea*, Antwerp, Plantin, 1554 and 1570
- *Maharil*, Cremona, Conti, 1558
- *Sefer Arba'ah Turim*, Cremona, Conti, 1558
- *Hazeruni*, Cremona, Conti, 1559
- *Sefer Tefilah le Mosheh*, Salonika, Joseph Jabez, 1563?
- *Sefer Orah Hayim*, Venice, Bragadin, 1563
- *Shulhan Arukh*, Venice, Bragadin, 1565
- *Kohelet/L'Ecclesiaste di Salome*, Venice, Ziletti, 1571

- *She'alot*. Venice, Zuan di Gara, 1574
- *Mishneh Torah*, Venice, Bragadin, 1574
- *Teshuvot HaRav*, Constantinople, Soncino, 1574
- Hai ben Sherira, *Shirei Musar HaSekhel*, Venice, Di Gara, 1578?
- *Pitron Halomot*, Cracow, 1580?
- Abraham Zacuto, *Sefer Yuchasin*, Cracow, Prostitz, 1580-1?
- Eliezer Ashkenazi, *Ma'asei Hashem*, Di Gara, Venice, 1583
- *Sefer Mikrae Kodesh*, Bragadin and Parenzo, Venice, 1586
- *Sefer Sha'arei Dimah*, Di Gara and Bragadin, Venice, 1586
- *Sefer Toledot Aharon*, Bragadin, Venice, 1591
- *Machzor*, Bragadin and di Gara, Venice, 1599
- *Behinat HaOlam*, Laqueray, Paris, 1629

Hb25 (S)

Appears on: Rés-X-1665, folios 2v
Size: (Grosse lettre)
Type Classification: Square Sephardic unpointed
Measurements: x-height of 6 mm
Date of creation: Unknown in Constantinople
Punchcutter: Unknown
Materials preserved: None
Type Specimens: None
Literature: None
First occurrence: *Arba'ah Turim*, Constantinople, 1494

Le Bé's annotation, which includes Hb26 (S) as well, indicates that these are types from Constantinople, 'apportees de Constantinople a Venise par un povre vieil Juif, pensant qu'elles fussent aussi rares a Venise comme en levant'. Thus one may conclude that Le Bé obtained these specimens during his stay in Venice, which would date them to a period pre-1540, and indeed the earliest occurrence found to date is from the Incunabula period (1494). These types do not appear to have been that rare as Le Bé thought, and it can be said that they were probably quite well dispersed throughout the Levant, meaning the Ottoman Empire. They show up again in the third quarter of the sixteenth century in Constantinople.

They also appear, with slightly amended detail in a series of Ferrara Hebrew publications from the 1550s. Usque purchased 'quatro sorte de madre de lettere' from Meir di Parenzo in August 1559 and although it is not stated that these were Hebrew matrices, it can be reasonably assumed that they were.⁵⁹⁶ This is a later date than the editions found with Hb25 (S), but it would make sense for Parenzo to have acted as a means of transmission for the sale of Hebrew types to other printers in Italy. The similarities between the Le Bé specimen and the Ferrara types are close enough to raise the question of their common ancestry, or the possibility that they were both cut by the same punchcutter

Le Bé's comment, that this typeface has 'hardis traitz (well-formed or bold strokes) but 'mal taillez' (poorly cut) indicates that he approved of the general style, but thought them badly executed from a professional point of view.



Fig. 4.11: Hb25 (S) Assembled alphabet Actual size from the Le Bé specimen

⁵⁹⁶ Archivio di Stato, Venezia, Notarile 8246_1559, folios 35-36

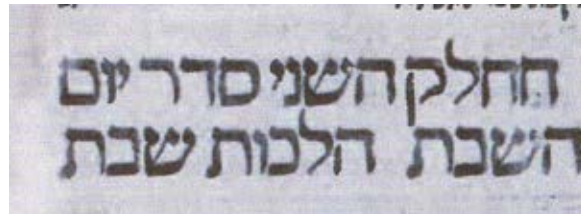

Fig. 4.12: Detail from 1494 *Arba'ah Turim*, Constantinople, 1494 (From the Hebrew JNUL Digitized Book Repository)



Fig. 4.13: Details from *Hamishah Humshe Torah*, Avraham Usque, Ferrara, 1554 (BL 1944.f.1)

Attributions for this typeface in printed editions:

- *Arba'ah Turim*, Constantinople, Nachmias, 1494
- *Hamishah Humshei Tora*, Constantinople, Nachmias, 1505
- Shimon ben Tsemach Duran, *Perush HaKetubah*, Constantinople, c. 1515
- *Mishpatei HaCherem, veHanidui, ve Hanezipha*, Constantinople, c. 1515
- *Sefer Behinat Olam*, Ferrara, 1551
- *Pitron Halomot*, Ferrara, 1552?
- *Me'ah Berakhot*, Ferrara, Usque, 1554?
- *Sefer Tsedah LaDerekh*, Ferrara, 1554?
- *Sefer Likute shikheah u-feah*, Ferrara, 1556?
- *Sefer Ma'arekhet HaElohut*, Ferrara, 1557?
- *Remu'ah*, Constantinople, 1565
- *Shoresh Yishai*, Constantinople Usque, 1561
- *Derech HaHayim*, Constantinople, 1570
- *Machzor*, Constantinople, 1576

Hb26 (S)

Appears on: Rés-X-1665, folios 2v

Size: (Grosse lettre)

Type Classification: Square Sephardic unpointed

Measurements: x-height of 4 mm

Date of creation: Unknown

Punchcutter: Unknown

Materials preserved: None

Type Specimens: None

First occurrence: *Rosh Emunah*, Constantinople, Nachmias and Caspota, 1506

This second specimen is a smaller version of Hb25 (S) and most probably cut by the same punchcutter as the previous. The forms of the shin and the gimmel are identical, but the ayin in this version has a decided 'kink' in the left hand stroke. An example of the earlier use found to date is shown below. Note the bent ascenders on the lamed showing wear on kerned characters and the bent hook on the left hand stroke of the ayin which is similar in both the Le Bé specimen and the printed detail of 1506.



Fig. 4.14: Hb26 (S) Assembled alphabet from the Le Bé specimen (Actual size)

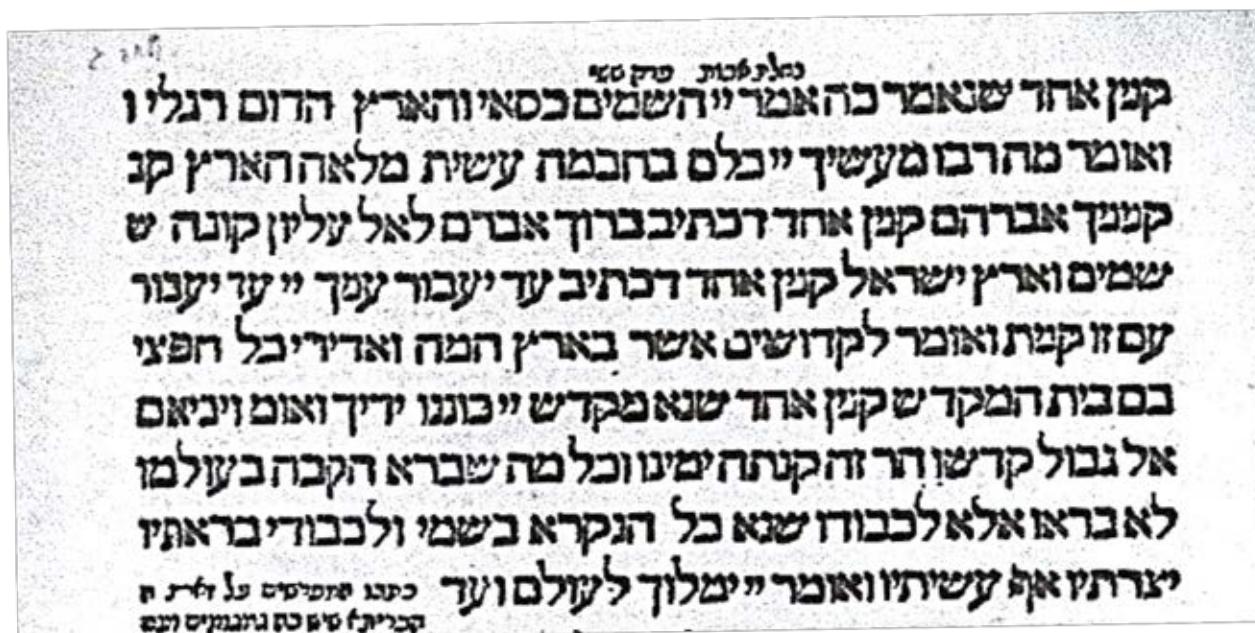

Fig. 4.15: Detail from *Rosh Emunah*, Constantinople, Nachmias and Caspota, 1506 (From the Hebrew JNUL Digitized Book Repository)

Attributions for this typeface in printed editions:

- *Hamishah Humshei Tora*, Constantinople, Nachmias, 1505
- *Rosh Emunah*, Constantinople, Nachmias and Caspota, 1506
- *Sefer Tehilim*, Salonika, 1522
- *Sefer Behinat Olam*, Ferrara, 1551
- *Sefer Tsedah LaDerekh*, Ferrara, 1554
- *Sefer Likute shikheah u-feah*, Ferrara, 1556
- *Sefer Ma'arekhet HaElohut*, Ferrara, 1557

Hb27 (S)

Appears on: Rés-X-1665, folios 4 and 5

Size: Two-line Great Primer or *Petit Canon* or *Trismégiste*/

Type Classification: Square Sephardic pointed

Measurements: x-height of 6 mm; 20:260 (vocalized)

Date of creation: 1541 (Vervliet mid-1543)

Punchcutter: Jean Arnoul dit Picard/ Paris

Literature: Vervliet, *Paleaotypography*, Vol 1, 142-143; Vervliet *Conspectus*, p. 417 [399/Hb 6]

Materials preserved: None

Type Specimens: Le Bé, Rés. X 1665, f. 4; Omont, 1887, 6; Berner, *Specimen characterum*, Frankfurt, 1622

First occurrence: *Quinque Libri Legis*, Paris, Robert Estienne, 1543

This typeface, and the four which follow it on the same sheet, form part what is most probably the first *complete* Hebrew type specimen ever recorded.⁵⁹⁷ This fact was not appreciated by Henri Omont when he first described the Le Bé documents in 1887, as the binder of the document had cut off the top line of Le Bé's annotation, but which was first recognised by Harry Carter⁵⁹⁸ and later confirmed by Hendrik Vervliet in his 2004 article on Robert Estienne's Printing Types.⁵⁹⁹ It has to be said that there were at least two earlier *specimens* of Hebrew setting, the first being a specimen of a Hebrew alphabet in Bernhard von Breydenbach's *Peregrinatio in Terram Sanctam* of 1490⁶⁰⁰ and the second a proof sheet for Aldus Manutius' project of 1502 to issue a Polyglot Bible in Hebrew, Greek and Latin. The Breydenbach is a table, most probably engraved in wood, showing an Ashkenazic Square Hebrew alphabet and the Manutius is a quarto sheet issued to publicise an edition, and are not *per se* specimens of Hebrew types.⁶⁰¹ The distinction between a specimen of setting and a type specimen is in the intention. It can either be 'to show the range of founts and material available for use in a certain printing office', or to show 'one of more typefaces, often including typographical materials, offered for sale by a particular punchcutter, type founder or merchant, or at an auction'.⁶⁰² This Estienne sheet bears all the hallmarks of a true type specimen, as it provides enough information for type size, leading and casting-off purposes.

Jehan (Jean) Arnoul dit le Picard is described in the *Le Bé Memorandum* as 'un nommé Jehan picard home le plus adoit a la proportion & grace des Caracteres quil fut en ce templa' and it was apparently this punchcutter who undertook to cut new

⁵⁹⁷ John A. Lane, Hendrik D. L. Vervliet, and British Library, *Early type specimens in the Plantin-Moretus Museum: annotated descriptions of the specimens to ca. 1850 (mostly from the Low Countries and France) with preliminary notes on the typefoundries and printing offices* (London and New Castle, Delaware: British Library and Oak Knoll Press, 2004), p. 15

⁵⁹⁸ Carter, *A view of early typography up to about 1600*, p. 43

⁵⁹⁹ Vervliet, 'Chapter 3', in *The Palaeotypography of the French Renaissance: Selected Papers on Sixteenth-Century Typefaces* (Leiden and Boston: Brill, 20048), p. 142

⁶⁰⁰ David Sclar, *Treasures of the Valmadonna Trust Library* (London and New York: Valmadonna trust Library, 2011), pp. 30-31

⁶⁰¹ Davies, *Aldus Manutius: printer and publisher of Renaissance Venice*, p. 52

⁶⁰² Lane, Vervliet, and Library, *Early type specimens in the Plantin-Moretus Museum*, p. 12

Hebrews for Robert Estienne to replace the ‘gros villain hebreu’ which appears in some of the earlier Estienne Hebrew bibles. Harry Carter notes that an earlier volume of 1540 (Zacharias, Song of Songs, Ruth, Lamentations, Jeremiah, Ecclesiastes and Esther) is printed in the Arnoul Hebrews.⁶⁰³ Based on a marriage document in the Archives Nationales from 1542 which describes Arnoul as a ‘maitre tailleur et fondeur de lettres’ and also living at ‘l’hostel de Robert Estienne’, Vervliet argues that Arnoul taught Guillaume Le Bé the craft of letter cutting and foundry. Vervliet also deduces that both Arnoul and Le Bé left Paris at the same time and ‘travelled to Lyons where Picard died’.⁶⁰⁴ The Le Bé annotation names Arnoul as ‘le jeune’, which implies that he was at least second in line to have the same name, but there appears to be no further documents to support this view.⁶⁰⁵

Le Bé gives no details as to size in his annotation for this typeface, but comments that it was ‘bien jollie et bien achevé, sentant sa plume’.⁶⁰⁶ Vervliet gives two possible equivalent sizes for this typeface, *Petit Canon* or *Trismégiste*, yet given the lack of adequate consecutive lines of setting in any specimen yet seen, it is difficult to be any more precise. The *Petit canon* size is equivalent to 180 to 219 mm per 20 lines, whereas *Trismégiste* is equivalent to 200 to 269 mm per 20 lines.⁶⁰⁷



Fig. 4.16: Hb27 (S) Specimen from 1665 f. 4



Fig. 4.17: Hb27 (S) Assembled alphabet from specimen and *Thesaurus Linguae Sanctae*, Geneva, Pierre de la Rouvière, 1614 (From the Google Books digital version)

The key identifying characters for this typeface are the lamed with its distinctive flagged ascender, the shin with the squared termination on the middle stroke and the gimmel with the bent middle stroke and calligraphic termination to the baseline. The

⁶⁰³ Le Bé, *The Le Bé memorandum*, pp. 17,40

⁶⁰⁴ Vervliet, *French Renaissance Printing Types: A Conspectus*, p. 42. The document in the AN is from the Minutier Central RE/XLIX/1A, Répertoire du notaire François Crozon.

⁶⁰⁵ See Philippe Renouard, Paris (France). Service des travaux historiques de la ville de Paris., and Bibliothèque nationale (France), *Imprimeurs & libraires parisiens du XVIIe siècle, Histoire générale de Paris*. (Paris: Service des travaux historiques de la ville de Paris, 1964), pp. 112-113 and Vervliet, *The Palaeotypography of the French Renaissance: Selected Papers on Sixteenth-Century Typefaces*, p. 142 (Vol. 141)

⁶⁰⁶ ‘Plume’ in this reference most likely means his ‘hand’ or style.

⁶⁰⁷ Vervliet, *French Renaissance Printing Types: A Conspectus*, p. 52

terminations are generally square as in the tsadde and the ayin. The text of the specimen is from Psalms 34:1.

The attributions for this Picard typeface show a very wide distribution: Geneva, Gießen, Frankfurt and Hanau in Germany. There are two possible explanations for this spread: André Wechel and Robert Estienne. Wechel reestablished himself in Frankfurt after fleeing from the St Bartholew's Day Massacre in 1572, and most probably managed to have some of his type brought to Frankfurt by Denis du Val, his associate in Paris.⁶⁰⁸ Robert Estienne also brought most of his type with him to Geneva, after leaving Paris in 1549.⁶⁰⁹ Recasting and recutting of some of the sorts could explain the differences in the two following examples from Kaspar Chemlin in Gießen and Christoph Wust in Frankfurt.

There is a specimen of this typeface in Johann Berner's 1622 Frankfurt specimen sheet. No punchcutter is attributed, but there is little doubt of the attribution.⁶¹⁰

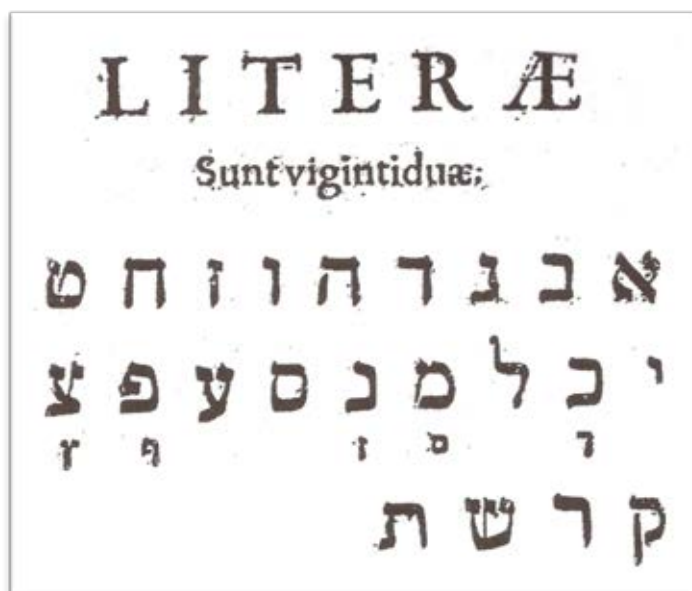

Fig. 4.18: Alphabet from *Elementale Hebraicum et Chaldaicum*, Gießen, Kaspar Chemlin, 1619. (From the Freimann Collection of the Frankfurt University Library)



Fig 4.19: Hb27 (S) Portion of specimen from Johann Berner's *Specimen Characterum*, Frankfurt am Main, 1622 (From *Type Specimen Facsimiles 1*, 1963)

⁶⁰⁸ Christoph Reske, *Die Buchdrucker des 16. und 17. Jahrhunderts im deutschen Sprachgebiet: auf der Grundlage des gleichnamigen Werkes von Josef Benzing, Beiträge zum Buch- und Bibliothekswesen, Bd. 51.* (Wiesbaden: Harrassowitz, 2007), p. 237

⁶⁰⁹ Armstrong, *Robert Estienne: Royal Printer*, p. 226

⁶¹⁰ Dreyfus et al., *Type specimen facsimiles 1-15*, p. 7

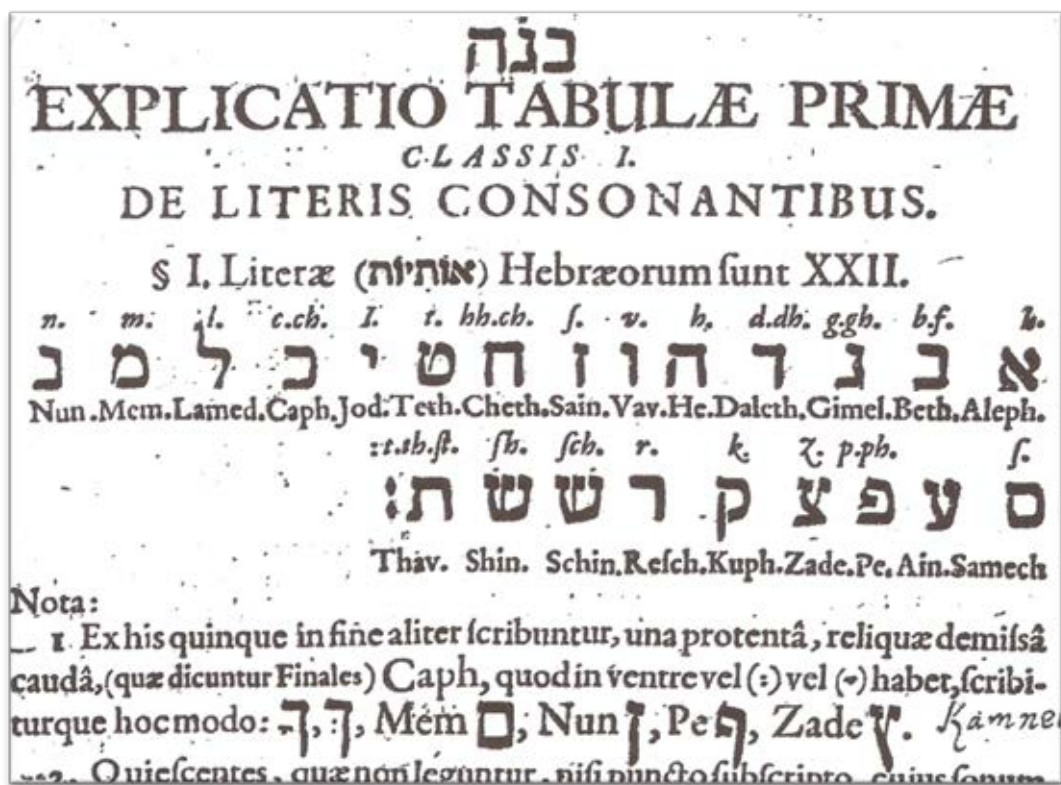

Fig. 4.20 Alphabet from *Menonsis Hannekenii Grammatica linguae Hebraeae*, Christoph Wust, Frankfurt, 1676 (The Freimann Collection of the Frankfurt University Library)

Attributions for this typeface in printed editions:

- *Quinque Libri Legis*, Paris, Robert Estienne, 1543
- *Psalterium/Sefer Tehilim*, Paris, Robert Estienne, 1545
- *Hosea*, Paris, Robert Estienne, 1546
- *Thesaurus Linguae Sanctae*, Paris, Robert Estienne, 1548
- *Sefer Hinukh*, Geneva, Robert Estienne, 1554
- *Sefer Ta'ami HaMikra/Liber de accentibus scripturae*, Paris, Henri Estienne, 1565
- *Chevallier Rudimenta Hebraicae Linguae*, Geneva, Henri Estienne, 1567
- *Hē Kainē Diathēkē*, Paris, Apud Ioannem Bene-natum, 1584?
- *Thesaurus Linguae Sanctae*, Geneva, Pierre de la Rouvière, 1614
- *Elementale Hebraicum et Chaldaicum*, Gießen, Kaspar Chemlin, 1619
- *Sefer Hakavanot*, Venice, Lorenzo Bragadin, 1620?
- *Machzor mi-Khol HaShanah*, Hanau, Typographia Orientalis, 1624?
- *Menonsis Hannekenii Grammatica linguae Hebraeae*, Frankfurt, Christoph Wust, 1676

Hb28 (S)

Appears on: Rés-X-1665, folios 4 and 5
Size: Picard's two-line Pica Hebrew or *Palestine/Gros-Parangon*
Type Classification: Square Sephardic pointed
Measurements: x-height of 4 mm; 20:177 (vocalized)
Date of creation: 1541 (Vervliet mid-1543)
Punchcutter: Jean Arnoul dit Picard/ Paris
First Occurrence: *Quinque Libri Legis*, Paris, Robert Estienne, 1543
Literature: Vervliet, *Paleaotypography*, Vol 1, 143; Vervliet *Conspectus*, p. 414 [396/Hb 4]
Materials preserved: None
Type Specimens: Le Bé, Rés. X 1665, folios 4 and 5; Omont, 1887, 6; Berner, *Specimen characterum*, Frankfurt, 1622

The second typeface on the Estienne specimen sheet has already been discussed in chapter 2 in connection with Le Bé's activities during his apprenticeship with Robert Estienne. To recapitulate: the *Le Bé Memorandum* relates that Estienne himself cut 'the big ugly Hebrew' which was used initially to print his quarto Hebrew Bible in some of the books issued separately. However, 'as the type proved not to be as agreeable as was hoped ... he (Estienne) had new faces cut for the 4^o Bible by a man named Jehan Picard'. Guillaume II Le Bé' then adds that 'my father was apprentice to Robert Estienne, that is to say in 1542, and he worked on these letters towards the end'.⁶¹¹ The most plausible explanation to this statement is that Guillaume I Le Bé worked on these types as an apprentice under Arnoul's supervision on the finishing of these types, but that the major engraving work was done by Arnoul himself. This would explain the clear stylistic differences between this typeface and those which Le Bé identifies as his own in the two BnF documents.

An analysis of all available editions of the Estienne quarto Hebrew Bible in the British Library dated from 1539 to 1545 shows that this typeface (Picard's Square Sephardic Hebrew on Two-Line Pica [Hb 4 mm] Gros-Parangon or Palestine) first began to be used in the 1543 edition of the *Quinque Libri legis/Hamishah Humshe Tora* (Genesis, Exodus, Leviticus, Numeri and Deuteronomium).⁶¹² There are two earlier editions which use it, *Michaeas* of 1539 and *Jonas* of 1540, but it is likely that these were reprints of earlier editions without changes to the date. Thus one can say with some certainty that these three typefaces cut by Picard, with some assistance by Le Bé, began to be used in the Estienne repertoire about September 1542.

A page from the Estienne Quarto Bible, Chronicles 1: 1-15 is shown on Réserve X 1665 folio 5, which uses Hb29 (S) for the text and Hb27 (S) for the heading within an engraved frame.

⁶¹¹ This is Harry Carter's English translation from Le Bé, *The Le Bé memorandum*, p. 29

⁶¹² The relevant British Library shelfmarks are 1.a.12-15 (1539), 1942.g.2. (1539), 676.e.7,8 (1543) 1942.b.11-13. (1544), 675.b.1-8. (1544), 219.b.18-25. (1544) – all entitled *Hamishah humshe Torah*

The 16mo edition, which began to appear in 1543, uses only the Picard types.⁶¹³ It was this edition which prompted Philippe Renouard to comment that ‘cette petite édition que l’on dit fort exacte, est vraiment un bijou typographique, et peut-être ce qui a jamais été imprimé de plus beau en langue hébraïque’. Renouard did comment that ‘il est seulement fâcheux que la grosseur des caractères ne soit pas en suffisante harmonie avec l’exiguïté du format’.⁶¹⁴ One could indeed argue that a size between Hb28 (S) and Hb29 (S) would have been more appropriate to the pocket-sized format, as can be seen in the Aldus Octavo Greek editions.⁶¹⁵ It is perhaps these Aldine editions that Estienne had in mind when he issued the 16mo Hebrew Bible.

The text of this specimen is the continuation of the text from the specimen in Hb27 (S) and is from Psalms 34:2-7. The characteristics of Hb28 (S) are similar to the other three Picards, with minor differences. In this typeface, for example, the ascender of the lamed is straighter and not ‘kinked’ as is the lamed of Hb27 (S). There are also sorts for the extended aleph, heh, lamed, final mem and tav. The specimen was cast on a larger body to allow for correct placement of the vowels and cantillation marks which must have been cast on a half-sized body.



Fig. 4.21: Hb28 (S) Assembled alphabet from 1665 folios 4 and 5, *Alphabetaum Hebraicum* 1544 and the *Duodecim Prophetae*, 1543 (BnF Inv Rés X 2603 and 2606)

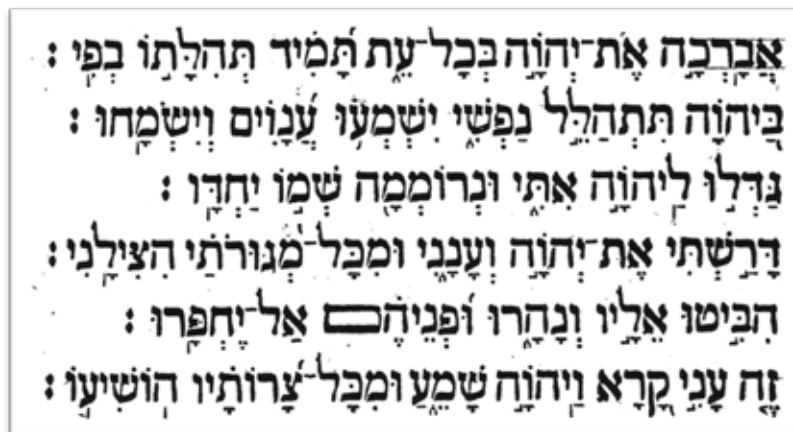

Fig. 4.22: Hb28 (S) specimen from Rés X 1665 f. 4 (Actual size)

⁶¹³ Schwarzfuchs and Coron, *Le livre hébreu à Paris au XVIIe siècle*, pp. 114-155. See also Fred Schreiber, *The Estiennes: an annotated catalogue of 300 highlights of their various presses* (New York (3140 Netherland Ave., Bronx, New York 10463): E.K. Schreiber, 1982), pp. 79-80

⁶¹⁴ Renouard, *Annales de l’Imprimerie des Estienne*, p. 65

⁶¹⁵ Ralph Stanton, ‘Aldus Pius Manutius - Publisher of Renaissance Venice’(2008) <<http://www.lib.sfu.ca/special-collections/projects/aldus>> [Accessed 13 September 2012]



Fig. 4.23: Page 95 from the *Duodecim Prophetae*, 1543, Joel (Lambeth Palace Library, E15.1543.DP)

This typeface and two of the other Picard Hebrews – Hb27 (S) and 32(S) – found their way further afield than Paris and Geneva, and were used in Hanau near Frankfurt in the seventeenth century. The specimen below from a *Machzor* printed in 1624 shows a Musaf prayer for the New Year (Rosh HaShanah) and includes a near complete listing of the alphabet: the text is a poem with an alphabetical acrostic. The printers in the colophon are given as Mordechai ben Ya'akov of Prostitz and Eliahu ben Yehuda of Hanau, which would tie them to the *Typographia Orientalis* of Hans Jakob Henne (1609-13) and Abraham Leo (1613-1630), but it is not clear how these types were acquired.⁶¹⁶

⁶¹⁶ Reske, *Die Buchdrucker des 16. und 17. Jahrhunderts im deutschen Sprachgebiet*, p. 348

As with Hb27 (S), there is a specimen of Hb28 (S) in Johann Berner's 1622 Frankfurt specimen, again without any attribution.⁶¹⁷

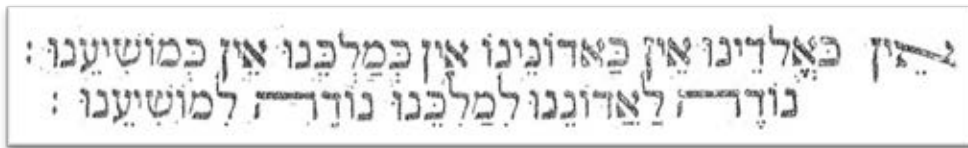

Fig. 4.24: Hb27 (S) Portion of specimen from Johann Berner's *Specimen Characterum*, Frankfurt am Main, 1622 (From *Type Specimen Facsimiles 1*, 1963)



Fig. 4.25: Page from *Machzor mi-Khol HaShanah*, Hanau 1624 Actual size (BL 1973c32)

⁶¹⁷ Dreyfus et al., *Type specimen facsimiles 1-15*, p. 7

Attributions for this typeface in printed editions:

- *Quinque Libri Legis*, Paris, Robert Estienne, 1543
- *Alphabetum Hebraicum*, Paris, Robert Estienne, 1544
- *Hosea*, Paris, Robert Estienne, 1546
- *Alphabetum Hebraicum*, Paris, Robert Estienne, 1550
- *Sefer Hinukh*, Geneva, Robert Estienne, 1554
- *Alphabetum Hebraicum*, Paris, Robert Estienne, 1563
- Judah ben Samuel Ibn Balam and Jean Mercier, *Sefer Ta'ami HaMikra/Liber de accentibus scripturae*, Paris, Henri Estienne, 1565
- Chevallier, *Rudimenta Hebraicae Linguae*, Geneva, Henri Estienne, 1567
- *Literae Illustriss*, Geneva, Henri Estienne, 1569
- *Gal-Ed/Comparatio Grammaticae Hebraica*, Geneva, Eustache Vignon, 1574
- *Alphabetum Graecum & Hebraicum*, Geneva, Paul Estienne, 1600
- *Machzor mi-Khol HaShanah*, Hanau, Typographia Orientalis, 1624

Hb29 (S)

Appears on: Rés-X-1665, folio 4
Size: Picard's English-sized Hebrew or *Saint-Augustin*
Type Classification: Square Sephardic pointed
Measurements: x-height of 2.2 mm; 20:97 (vocalized)
Date of creation: 1541 (Vervliet mid-1543)
Punchcutter: Jean Arnoul dit Picard/ Paris
First Occurrence: *Duodecim Prophaetae*, Paris, Robert Estienne, 1539
Literature: Vervliet, *Palaeotypography*, Vol 1, 144; Vervliet *Conspectus*, p. 397
Materials preserved: None
Type Specimens: Le Bé, Rés. X 1665, f. 4; Omont, 1887, 6; Berner, *Specimen characterum*, Frankfurt, 1622

The third typeface attributed by Le Bé to Jean Arnoul dit Picard le Jeune is this 2.2mm Square Sephardic Hebrew. The text of this specimen is the continuation of the text from the specimen in Hb28 (S) and is from Psalms 34:8-18.



א אבנדה רהוזחטיכך לרלמס סנן סעפןצץ קרשתרת :

Fig. 4.26: Hb29 (S) Assembled alphabet from Le Bé specimen and *Rudimenta Hebraicae Linguae*, Henri Estienne, Geneva, 1567 (BL 621.i.8)

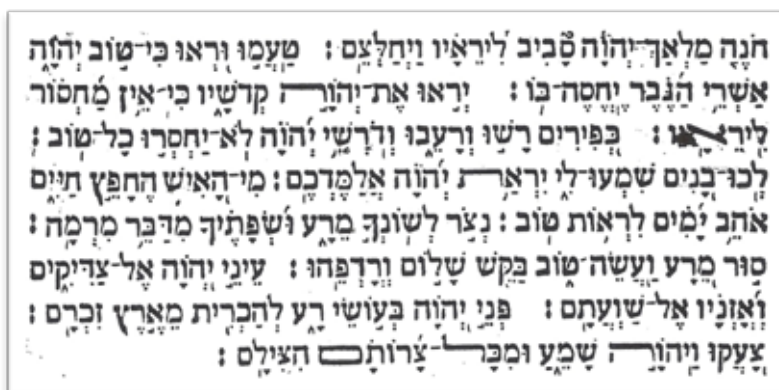

חנה מלאך יהוה סביב ליראיו ויחלצם : טעמו וראו כי טוב יהוה
אשרי הנבר יחסה בו : יראו את יהוה קדשיו כי אין מחסור
ליראיו : בפירות רשו ורעבו ודרשו יהוה לא יחסרו כל טוב :
לכר בנים שמעו לי יראת יהוה אלמדכם : מיהאיש החפץ תיים
אהב ימים לראות טוב : נצר לשונך מרע ושפתך מדבר מרמה :
סור מרע ועשה טוב בקש שלום ורדפהו : עיני יהוה אל צדיקים
ואזניו אל שועתם : פני יהוה בעושי רע להכרית מארץ זכרם :
צעקו ויהוה שמע ומכר צרותם הצילם :

Fig. 4.27: Hb29 (S) Specimen from 1665 folio 4



Fig. 4.28: Hb29 (S) Twenty-line setting from *Rudimenta Hebraicae Linguae*, Henri Estienne, Geneva, 1567 (BL 62118)

There is no surviving material of this typeface, but one can see from the specimens that Picard would have cut a full set of both vowels and cantillation marks. These can be seen together in the Le Bé Biblical specimen, but not in the Estienne grammatical work. Thus we can only guess at the complete number of punches and matrices in the complete fount, but a safe assumption is that there would have been separate punches for the main characters, some with dagesh points, and separate punches for each of the vowels and cantillation marks. It is more problematic to say how they were struck on the matrix, but again following the example of Plantin casting bill, they were probably cast on smaller (half) bodies to fit in with the main set of the characters.⁶¹⁸ A good indication of the number of possible combinations – over 300 – can be gauged from the following example of a Hebrew fount compiled by Horace Hart, Printer to the University of Oxford and Controller of the University Press between 1883 and 1915. It should be noted that this specimen shows *only* the possible vowels and dagesh points and does *not* include any cantillation marks.⁶¹⁹

⁶¹⁸ See page 181 in Chapter 3 of this thesis.

⁶¹⁹ Bound booklet seen in the Harry Carter Archives at Oxford University Press Archives OUP/PR/25/23 (File of type specimens)

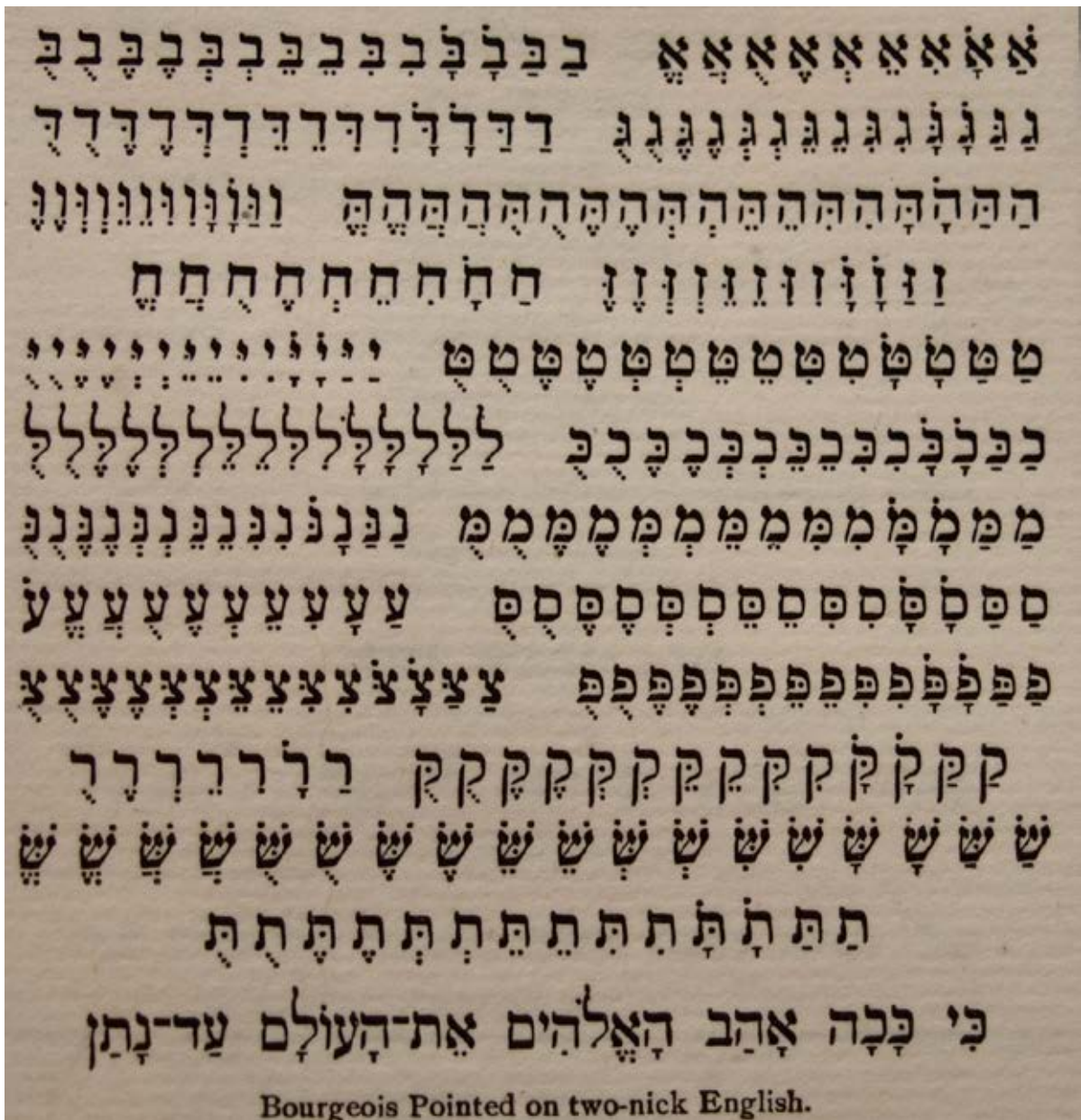

Fig. 4.29: Hebrew vowel combinations, (From OUP Archives, OUP/PR/25/)

This schema is by no means exhaustive as to the total number of combinations of basic glyphs, glyphs with dagesh points, vowel points (nekudot), and cantillation marks (simanei ta'amin) that might be required for a full Biblical setting. As an example, an analysis of all the glyphs from the first chapter of Genesis produced a total of 443 separate 'sorts' and a similar analysis of Psalm 34 produced a total of 297 separate 'sorts'. Both of these texts are found in the Le Bé documents – in Hb13 (S) and in Hb46 (S) – and give an indication of the complexities facing Le Bé in the cutting of pointed Hebrew founts.⁶²⁰

The total number fo sorts that could be held in a wooden type case was in any case limited and could not contain all the various combinations in a pointed Hebrew text.

⁶²⁰ See Appendix J of this thesis.

This is confirmed by the layout of Hebrew type cases as illustrated in historic printing manuals.⁶²¹

A total compilation of all the possible combinations in the entire Masoretic Hebrew Bible would certainly be in the thousands. To the best knowledge of this writer, no such attempt was ever made by a Jewish commentator. The closest attempt was a rather obscure poem probably written by the tenth century Biblical philosopher, and exegete Sa'adia Gaon, who wrote a poem entitled 'On the Number of the Letters of the alphabet'. The total number for the base characters – excluding final letters and any 'diacriticals' – is 304,804, although it is not clear how he arrived at this number.⁶²² A more recent estimate for the SBL Hebrew fount is around 13,200 possible combinations.⁶²³

The only way that punchcutters such as Le Bé would have had to cope with the enormous range of possibilities would have been to cut *separate* punches for each 'element' and then to cast them on modular units. This is in fact the evidence from the Hebrew founts at the MPM. Spacing would have been cast to fit these modular units, which then would have allowed lines to be set with all relevant glyphs and accents. This is confirmed by the surviving punches and matrices in the Plantin Moretus Museum and the casting register also in the Plantin Moretus archives.⁶²⁴ It is also shown in the schema recently suggested by Scott-Martin Kosofsky as shown on page 272. The modular units he proposes would have allowed the composition and secure locking of formes of any relevant combination of glyphs and accents.

This method is also confirmed by the lay of Hebrew type cases already described. No type case could have accommodated such an enormous number of sorts. And it was equally important for the compositors or the apprentices whose job would usually have been to distribute used type to the type case (to dis) to have the minimum number of sorts which they distinguish. It needs to be remembered that many of the people working in the presses of the sixteenth century had little or no knowledge of Hebrew. This was certainly the case during the production of the Antwerp Polyglot Bible.⁶²⁵

It is instructive to compare Hebrew composition with other exotic alphabets on this issue. Syriac, for example, is an alphabet containing 22 letters – the same as used in Hebrew and Aramaic. There are also alternate final forms for the kaph, mem, and nun, as well as some differing forms for standalone, initial, medial and final, as in the

⁶²¹ See page 174 in this thesis for further discussion and examples.

⁶²² See J. Derenbourg, 'Manuel du Lecteur', *Journal Asiatique*, XV (Sixieme serie) (1870) and Henry Malter, *Saadia Gaon: his life and works* (Philadelphia: Jewish Publications Society of America, 1921), pp. 154-157. See also Aishdas, 'Pamphlet 9 - The Letters of the Torah' (2002) <http://www.aishdas.org/toratemet/en_pamphlet9.html> [Accessed 28 July 2013]

⁶²³ Email correspondence from John Hudson of Tiro Typeworks, Gulf Islands, British Columbia, Canada, 25 July 2013

⁶²⁴ See page 182 of this thesis.

⁶²⁵ For more detailed discussion of this issue see Lubell, *The Use of Hebrew in the Antwerp Polyglot Bible*, pp. 48-49

Arabic script. The total number of sorts in a fount of Estrangela Syriac is 72. Syriac also requires vowel points as in Hebrew, and there are two different methods for casting them. The first was ‘to cast the points on the same body as the letters’ with ‘the point set in the line after the relevant letter’. The second method was to set the vowels ‘on separate lines above and below the letters’. This second approach appears to have been the preferred method. The compositor had ‘to set and justify the lines of letters first, then do the same for the lines of points above, the turn the two lines upside down in the composing stick and set and justify the line above’. This is in fact the method for setting Hebrew as described by Lefèvre in his *Guide Pratique du Compositeur d’Imprimerie* of 1858.⁶²⁶ J.F. Coakley also suggests that, given the large number of matrices required for a full setting fount of Syriac – ‘upward to a thousand for all combinations of letters, vowels, diacritical points, *qushaya*, *rukaka* and *linea occultans*’ – that the portmanteau sorts would have been cast with all possible points for a particular character and then the unwanted ones removed prior to composition. The evidence for this technique with regard to Hebrew was discussed in Chapter Three.⁶²⁷ It is however useful to compare composition techniques for Hebrew with the techniques used for composition of music. The emboîtage technique as described by Laurent Guillo (see page 163) has strong similarities with Scott-Martin Kosofsky’s proposed composition technique for Hebrew.

⁶²⁶ See page 186 of this thesis.

⁶²⁷ J. F. Coakley, *The typography of Syriac: a historical catalogue of printing types, 1537-1958* (London: British Library, 2006), pp. 4, 17-24. See also 165 in this thesis.



Fig. 4.30: Biblical Hebrew setting schema for metal type. (By permission of Scott-Martin Kosofsky)

Attributions for this typeface in printed editions:

- *Duodecim Prophaetae*, Paris, Robert Estienne, 1539
- *Alphabetum Hebraicum*, Paris, Robert Estienne, 1539
- *Biblia Sacra*, Paris, Ex officina Simonis Colinaei, 1541?
- *Quinque Libri Legis*, Paris, Robert Estienne, 1543
- *Alphabetum Hebraicum*, Paris, Robert Estienne, 1544
- *Psalterium/Sefer Tehilim*, Paris, Robert Estienne, 1545
- *Hosea*, Paris, Robert Estienne, 1546
- *Alphabetum Hebraicum*, Paris, Robert Estienne, 1550
- *Sefer Hinukh*, Geneva, Robert Estienne, 1554
- *Alphabetum Hebraicum*, Paris, Robert Estienne, 1563
- *Sefer Ta'ami HaMikra/Liber de accentibus scripturae*, Paris, Henri Estienne, 1565
- *Chevallier Rudimenta Hebraicae Linguae*, Geneva, Henri Estienne, 1567

- *Litterae Illustriss*, Geneva, Henri Estienne, 1569
- *Gal-Ed/Comparatio Grammaticae Hebraica*, Geneva, Eustache Vignon, 1574
- *Isagoge Gil. Genebrardi*, Paris, Gilles de Gourmont, 1587
- *Johannis Rainoldi Angli, De Romanae ecclesiae idololatria*, Geneva, Jacob Stoer, 1598?⁶²⁸
- *Alphabetum Graecum & Hebraicum*, Geneva, Paul Estienne, 1600
- *Machzor mi-Khol HaShanah*, Hanau, Typographia Orientalis, 1624

⁶²⁸ This edition – see also Hb30 (S) – is provisional as there are not enough characters to make a complete attribution. Stoers reprinted a Henri Estienne edition of the *Alphabetum Hebraicum* and Schwarzfuchs writes that ‘ il utilise les caractères des Estienne, dont il représentait les intérêts aux foires de Francfort ...’. See Schwarzfuchs, *L'hébreu dans le livre à Genève au XVIe siècle*, pp. 36-37

Hb30 (S)

Appears on: Rés-X-1665, folio 4
Size: Picard's Pica Hebrew or Cicero.
Type Classification: Square Sephardic pointed
Measurements: x-height of 1.8 mm; 20:80 (vocalized)
Date of creation: 1541 (Vervliet 1545)
Punchcutter: Jean Arnoul dit Picard/ Paris
Literature: Vervliet *Conspectus*, p. 319
Materials preserved: None
Type Specimens: Le Bé, Rés. X 1665, f. 4; Omont, 1887, 6;
First occurrence: *Alphabetum Hebraicum*, 1543

This is the third and last Hebrew typeface attributed to Jean Arnoul by Le Bé on the Estienne specimen sheet. Given the vowels and cantillation marks, it was obviously intended for setting Biblical text or perhaps, given its small size, for cross references. Few examples of this type were found, with the exception of the 1543 Estienne *Alphabetum Hebraicum* and the 1556 *Liber Psalmorum Davidis* which was printed in Geneva. It was also used at the end of the sixteenth century by the printer Jean II de Tournes, who was active first in Lyons, and later in Geneva, where he printed works for the descendants of André Wechel, and his sons-in law Claude de Marne and Jean Aubri (Aubry).⁶²⁹ This type must have been first brought to Geneva by Robert Estienne when he left Paris, but its small size may have limited its usefulness as a text type except in very small formats. The text is from Psalms 34:19-23.

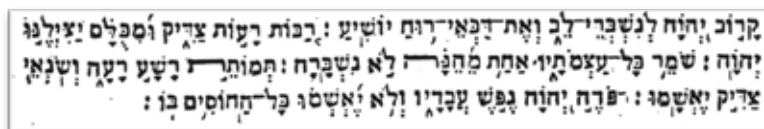

Fig. 4.31: Specimen from Le Bé 1665 f. 4

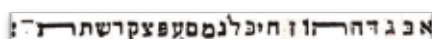

Fig. 4.32: Hb30 (S) Assembled alphabet from Le Bé 1665 f. 4 and *Liber Psalmorum Davidis*, Geneva 1556 (From e-rara.ch Bb 515)

⁶²⁹ *Ibid.*, pp. 37-38. See discussion in Chapter 2 in this thesis.

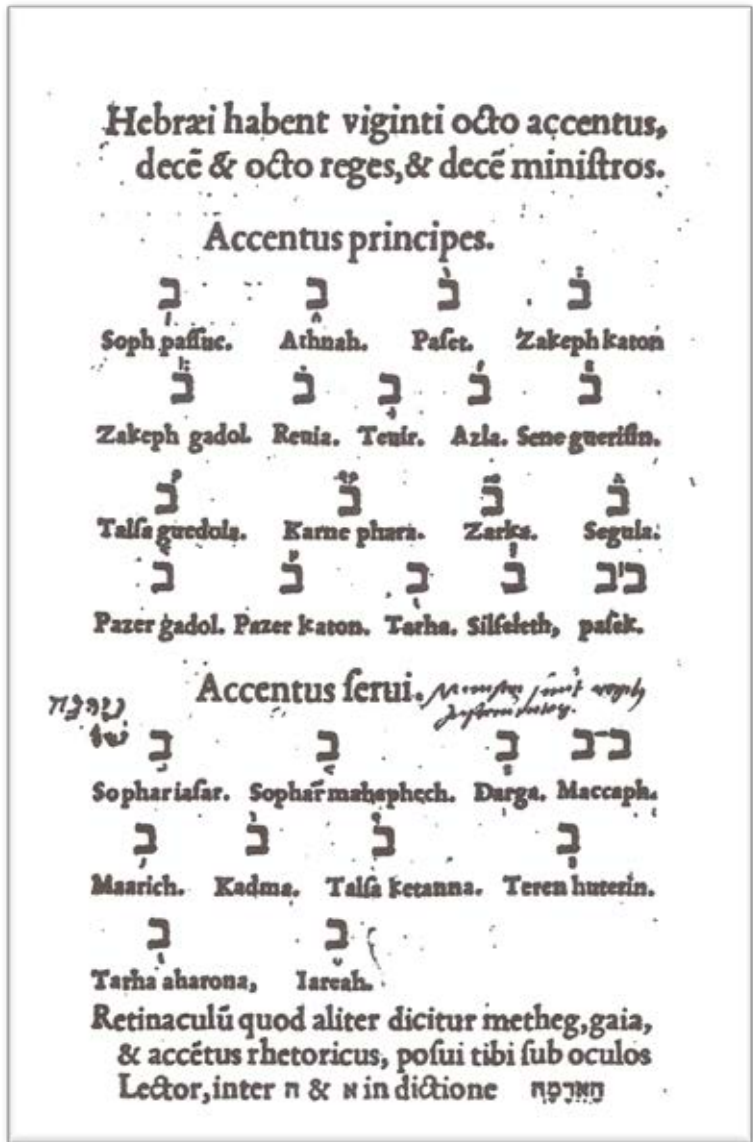

Fig. 4.33: Specimen of Hb30 (S) (seen on the bottom line of text) from the 1543 Estienne *Alphabetum Hebraicum*. Actual size (From BSB L.as.123)

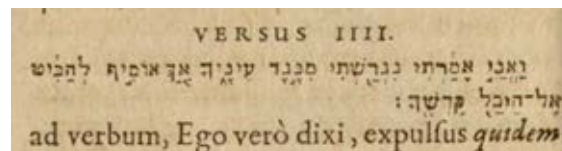
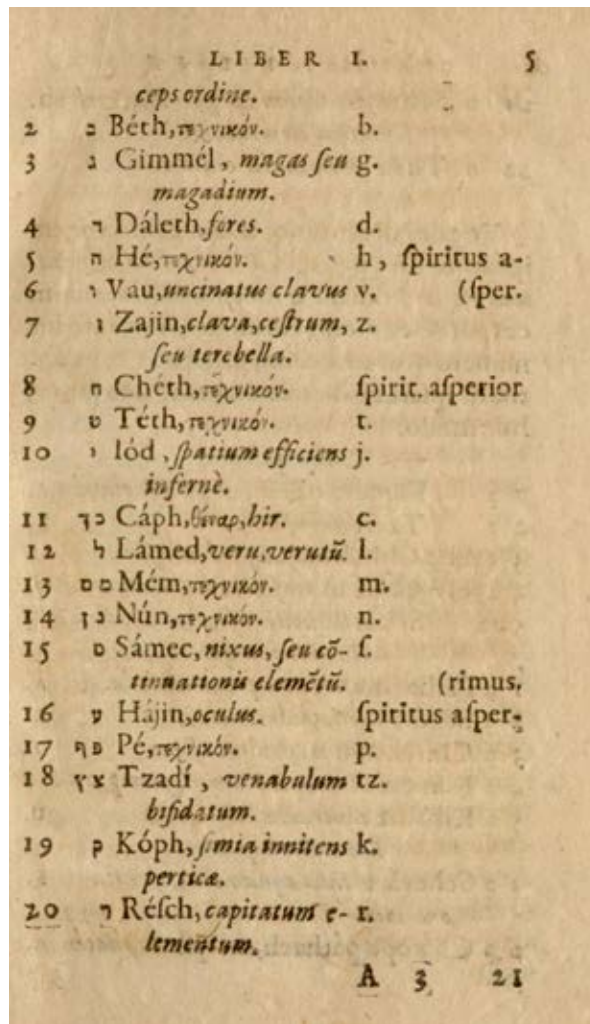

Fig. 4.34: Specimens of Hb30 (S) from *Franciscus Iunii Grammatica hebraeae linguae*, Geneva, Jean II de Tournes, 1596 Actual Size (From e-rara (Universitätsbibliothek, Basle, FB X22:1)

Attributions for this typeface in printed editions:

- *Alphabetum Hebraicum*, Paris, Robert I Estienne, 1543
- *Liber Psalmorum Davidis*, Geneva, Robert I Estienne, 1556-57
- *Testamenti Veteris Biblia Sacra*, Geneva, Excudebat Ioannes Tornaesius, Imprensis Andrae Weceli Haerdum, 1596
- *Francesci Iunii Grammatica hebraeae linguae*, Geneva, apud Ioan. Tornaesium, Imp. And. Wecheli Haerdum, Claudii Marnii, & Joannis Aubrii, 1596
- *Johannis Rainoldi Angli, De Romanae ecclesiae idololatria*, Geneva, Jacob Stoer, 1598?

Hb31 (R)

Appears on: Rés-X-1665, folio 4

Size: Estienne Rabbinical Hebrew on English [Hb 2] or *Saint-Augustin*

Type Classification: Rashi Script unpointed

Measurements: x-height of 2 mm; 20:94

Date of creation: 1541 (Vervliet mid-1543)

Punchcutter: Michel Du Boys?

Literature: Vervliet, *Paleaotypography*, Vol 1, 140; Vervliet *Conspectus*, p. 396

Materials preserved: None

Type Specimens: Le Bé, Rés. X 1665, f. 4; Omont, 1887, 6; Berner, *Specimen characterum*, Frankfurt, 1622

First occurrence: *Alphabetum Hebraicum*, Robert Estienne, Paris, 1539

This final specimen on Rés X 1665, folio 4 is not attributed to Jean Arnoul, but Le Bé writes in his annotation that 'et la glose taillé par un aultre, bien pollie et bien achevé, sentant sa plume'.⁶³⁰ This last phrase can be translated as 'showing the feel of his hand', and Le Bé uses a similar phrase in 4528, folio 19, when describing the *petites capitales latines et grecques* which he cut for the printer Zanetti in Venice in 1548.⁶³¹ Vervliet attributes this glose conjecturally to Michel Du Boys. Du Boys was active as a punchcutter from c. 1510 to 1561, and there are traces of his activities in Paris, Geneva, Venice and Lyons.⁶³²

This typeface proved to be a very useful and successful fount in the Estienne repertoire. It is clear and extremely legible for use as commentaries, as well as incorporating distinctive ascenders such as the lamed, and descenders, such as the ayin, the tav, the koph and the final nun. Although the punchcutter has followed the standard letterforms for Rashi script, the shin is closer to the square Sephardic model. It could be said that Le Bé took some inspiration from it for his later Rashi types, such as Hb18 (R) and Hb19 (S).

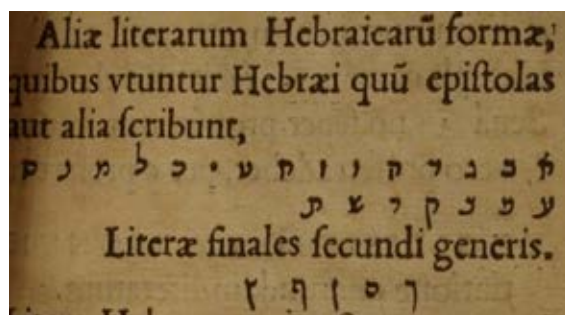

Fig. 4.35: Hb31 (R) Alphabet from *Alphabetum Hebraicum*, Robert Estienne, Paris, 1539, p. 5 (BnF Rés-X-1662)

⁶³⁰ 'Plume' in this reference most likely means his 'hand' or style.

⁶³¹ 'qui sent sa plume courante'. I am grateful to Mr Sandy-Pascal Andriant of FranceGenWeb and his extraordinary transcriber, M-Françoise, for their assistance in clarifying the text of this annotation.

⁶³² Vervliet, *French Renaissance Printing Types: A Conspectus*, pp. 40-41

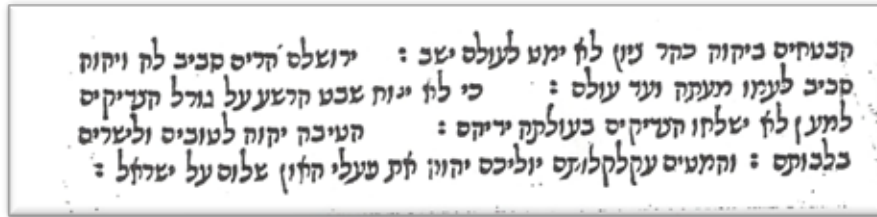

Fig. 4.36: HB31 (R) Le Bé specimen from 1665 folio 4



Fig. 4.37: HB31 (R) Detail of 20 lines from Hosea, *Duodecim Prophetae*, Robert Estienne, Paris, 1539 (BnF Rés-X-NFA 3)

Attributions for this typeface in printed editions:

- *Alphabetum Hebraicum*, Paris, Robert Estienne, 1539
- *Duodecim Prophaetae*, Paris, Robert Estienne, 1539
- *Alphabetum Hebraicum*, Paris, Robert Estienne, 1544
- *Psalterium/Sefer Tehilim*, Paris, Robert Estienne, 1545
- *Hosea*, Paris, Robert Estienne, 1546
- *Alphabetum Hebraicum*, Paris, Robert Estienne, 1550
- *Sefer Hinukh*, Geneva, Robert Estienne, 1554
- *Alphabetum Hebraicum*, Paris, Robert Estienne, 1563
- *Sefer Ta'ami HaMikra/Liber de accentibus scripturae*, Paris, Henri Estienne, 1565
- *Gal-Ed/Comparatio Grammaticae Hebraica*, Eustache Geneva, Vignon, 1574

- *Alphabetum Graecum & Hebraicum*, Geneva, Paul Estienne, 1600
- Hugh Broughton, *Patshegen Nishtevan*, Amsterdam, 1606
- Johann Rittangel, ספר יצירה *id est Liber Ierzirah*, Amsterdam, Apud Johannum et Jodocum Ianssonios, 1642?

Hb32 (S)

Appears on: Rés-X-1665, folios 7, 7v, 9, 9v
Size: Grosse Lettre/Gros-Parangon?
Type Classification: Square Sephardic unpointed
Measurements: x-height of 4 mm
Date of creation: Unknown
Punchcutter: Unknown
Materials preserved: None
Type Specimens: Le Bé, Rés. X 1665, folios 7, 7v, 9, 9v,
First occurrence: Third Bomberg *Biblia Rabbinica* of 1548?

This specimen is found in the first of four inserts which have been bound into the spine of Rés. X 1665, and which were not pasted onto the leaves as with the other specimens. This first insert comprises two distinct pages from the Bomberg Hebrew opus, with the second bound into the centre of the first, using a 'guard' to hold it into place.

The first page (folios 7, 7v, 9 and 9v) is from the third Bomberg *Biblia Rabbinica* of 1548, a folio edition, and is a part of the page from 2 Samuel: 1-6, together with part of the commentary by the fourteenth-century biblical commentator Rabbi Levi Ben Gershon or Gersonides, known as the 'Ralbag' (רלב"ג). The second page (folios 8 and 8v) is from an unidentified Bomberg quarto Bible and comprises part of Jeremiah, part of two Haftarot, those for 'Shemot' and 'Mattot' (Jeremiah 1:4)-12 with the commentary by the thirteenth-century Biblical commentator David Kimhi, known as the 'Radak' (קדק). The verso of this page (folio 8v) comprises parts of Ezekiel: 28:25 - 29:26 and 29:5, which is part of the haftarah Shemot (Exodus). These pages are taken from printed editions which came into the possession of Le Bé, as he obviously kept specimen of other Hebrew editions which were of interest to him.⁶³³

These pages demonstrate the complexity and number of typefaces used for setting a Hebrew Bible together with the various commentaries that surround it. There are three 'display' founts – including the already described Hb24 (S), three sizes of pointed and unpointed founts for the main text, and two sizes of Rashi Script for the commentaries and side references. The same complexity would hold for the setting of the Talmud. The various colophons and introductions in the Bomberg Rabbinical Bibles do not appear to name any of the punchcutters for these founts. For example, in his introduction to the first Rabbinic Bible edited by Felix Pratensis, Bomberg writes that 'I have employed intelligent and skilful typographers to print in moveable type and in the most perfect and correct manner the Law, the Prophets and the Hagiographia'. And in the Jacob ben Chayim's account of the making of the second

⁶³³ I am grateful to Dr. Jeremy Schonfield for his clarification on these extracts. A 'Haftarah' (plural 'Haftarot') is a selection from the Prophets to be read on special occasions, such as the Sabbath, the Holidays and Fast Days) after the public reading of the Torah.

Rabbinic Bible of 1524-1525, he emphasised the great expenses paid out by Bomberg for the Bible (whose expenses in this matter far exceeded my labours).⁶³⁴

In 1515, when Bomberg applied to the Venetian Collegio dei Savi for a patent for his Hebrew types and a privilege for his Hebrew editions, one of his arguments was that it had cost him 'grande spese si del far excider le lettere hebree et attrovar persone doctissime in hebreo al companer et emendar ditti libri'.⁶³⁵ A recent study of Bomberg's opus concluded that 'it is not known who cut the types for Bomberg' and, one can make a safe assumption that he would have used local craftsmen, either professional punchcutters or engravers, in Venice or in other cities of Italy. Such work would have required quite close supervision on his part in order to provide the requisite punches, matrices and moulds.⁶³⁶ Joshua Bloch claimed that Le Bé produced six different Hebrew fonts for Bomberg during his residence in Venice (1545-1548 and again in 1556), but aside from the obvious mistakes in dates, there is no documentary evidence whatsoever for this assertion.⁶³⁷ Le Bé attributes various typefaces to Bomberg, as will be seen, but does not claim them for his work in any of the annotations.

Bomberg's application for a privilege for his Hebrew types was not an exceptional event in this period. In 1498, for example, the Cretan printer Nicolò Vlasto Candioto received a privilege for ten years to protect his Greek types, which he had 'facto intagliar ... sorte de belletissime lettere, grece unide con i suo accenti, cosa che non fu mai più facte nè si bona nè cussì bella, che fe privilegio per anni dieci di stampare libri greci con questi caratteri', although he does not appear to have printed any editions in Greek after the year 1500.⁶³⁸ No such privilege has yet been found for any of Le Bé's Venetian Hebrews.

This 4 mm Square Sephardic was not seen in any other editions examined for this thesis, but there is a marked similarity both in size and in style with this fount to Le Bé's Hb10(S), which was cut in 1548 for Meir di Parenzo in Venice. Given the small number of characters in the specimen and the heavy inking of the impression, it is not possible to make a clear identification of all the characters, but the gimmel and the lamed are close enough to raise the possibility that this Le Bé typeface found its

⁶³⁴ Ginsburg, *Introduction to the Massoretico-critical edition of the Hebrew Bible*, pp. 934-935, 956-957

⁶³⁵ Brown, *The Venetian Printing Press*, p. 105 (much money and to have cut the Hebrew letters and to attract knowledgeable people to compose and correct these books.)

⁶³⁶ Kalman, *The Bookcraft of Daniel Bomberg's Press*, p. 89

⁶³⁷ Joshua Bloch, 'Venetian Printers of Hebrew Books', *Bulletin of the New York Public Library*, 36 (1932), p. 80. This assertion was also roundly refuted in one of Moses Marx's unpublished review of this article. See Moses Marx, *History and annals of Hebrew printing in the fifteenth and sixteenth centuries* (Cincinnati: Hebrew Union College, 1982)

⁶³⁸ Essling, 'Archivio di Stato di Venezia ("Archivietto")', Stampatori, Ricerca Duca di Rivoli', and Christopher Long, 'Nicolas Vlasto, Printer & Publisher, Venice C15th' (2000) <<http://www.christopherlong.co.uk/per/vlasto.nicolas.html>> [Accessed 14 April 2013]

way via Meir di Parenzo to Baruch Adel kind,⁶³⁹ and was used for this Bomberg edition.



Fig. 4.38: Hb10(S) Assembled alphabet

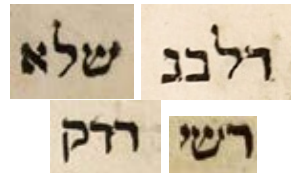

Fig. 4.39: Samples of headings from third Bomberg *Biblia Rabbinica* of 1548 (Actual size)

⁶³⁹ Adelkind was in the employ of Daniel Bomberg, from 1524 to 1544 and most likely retained close connections with him after he (Adelkind) took on the role of an independent publisher. See Avraham Meir Habermann, *HaMadpis Daniel Bombergi veReshimat Sefri Beit Defuso (The Printer Daniel Bomberg and a list of books published by his press)* (Zefat: Museum of Printing Art in Zefat, 1978).

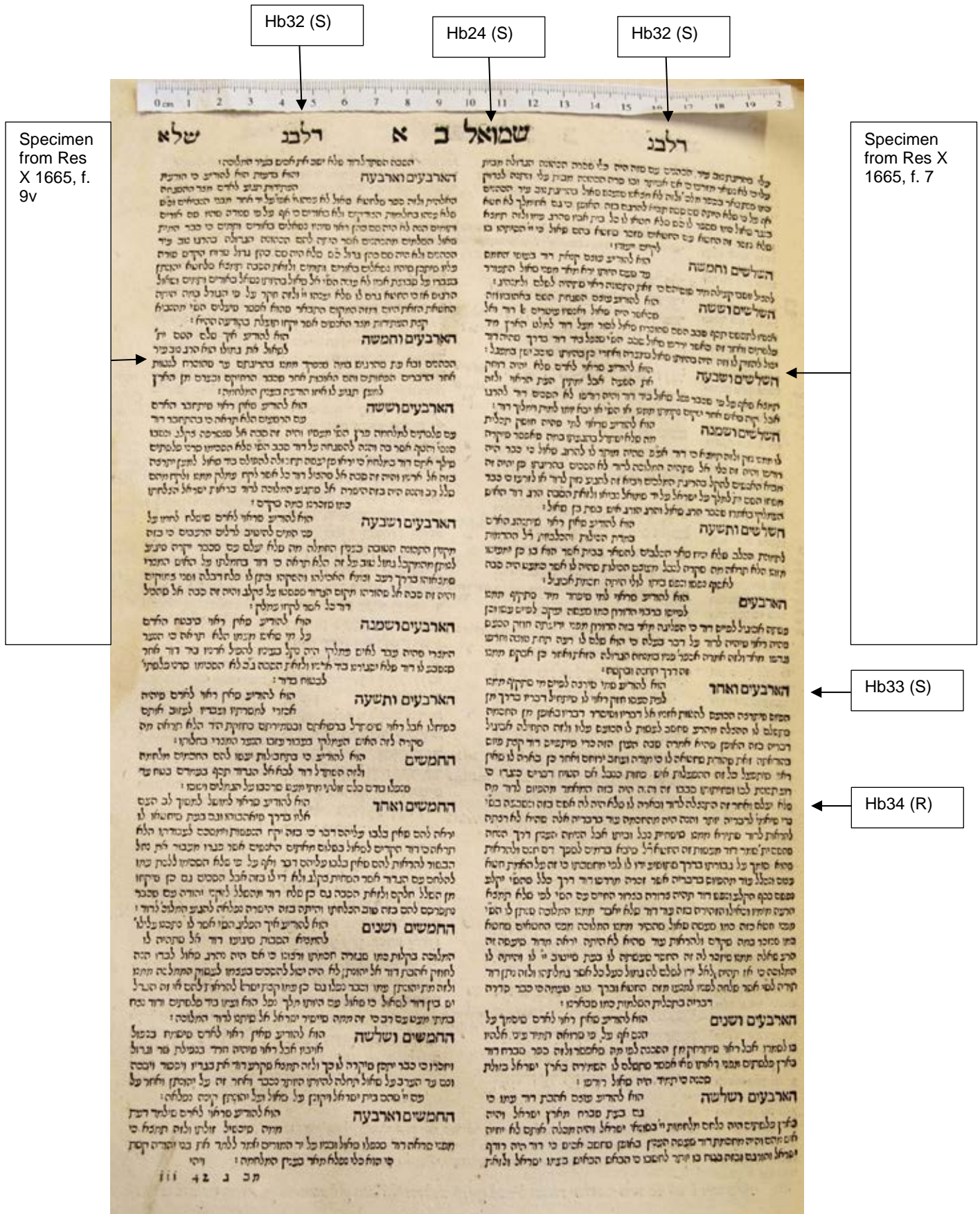

Fig. 4.40: Full Page from Bomberg *Biblia Rabbinica* of 1548, showing the sections reproduced on 1665 Folios 7 and 9v Reduced 70 per cent (Leo Baeck Library)

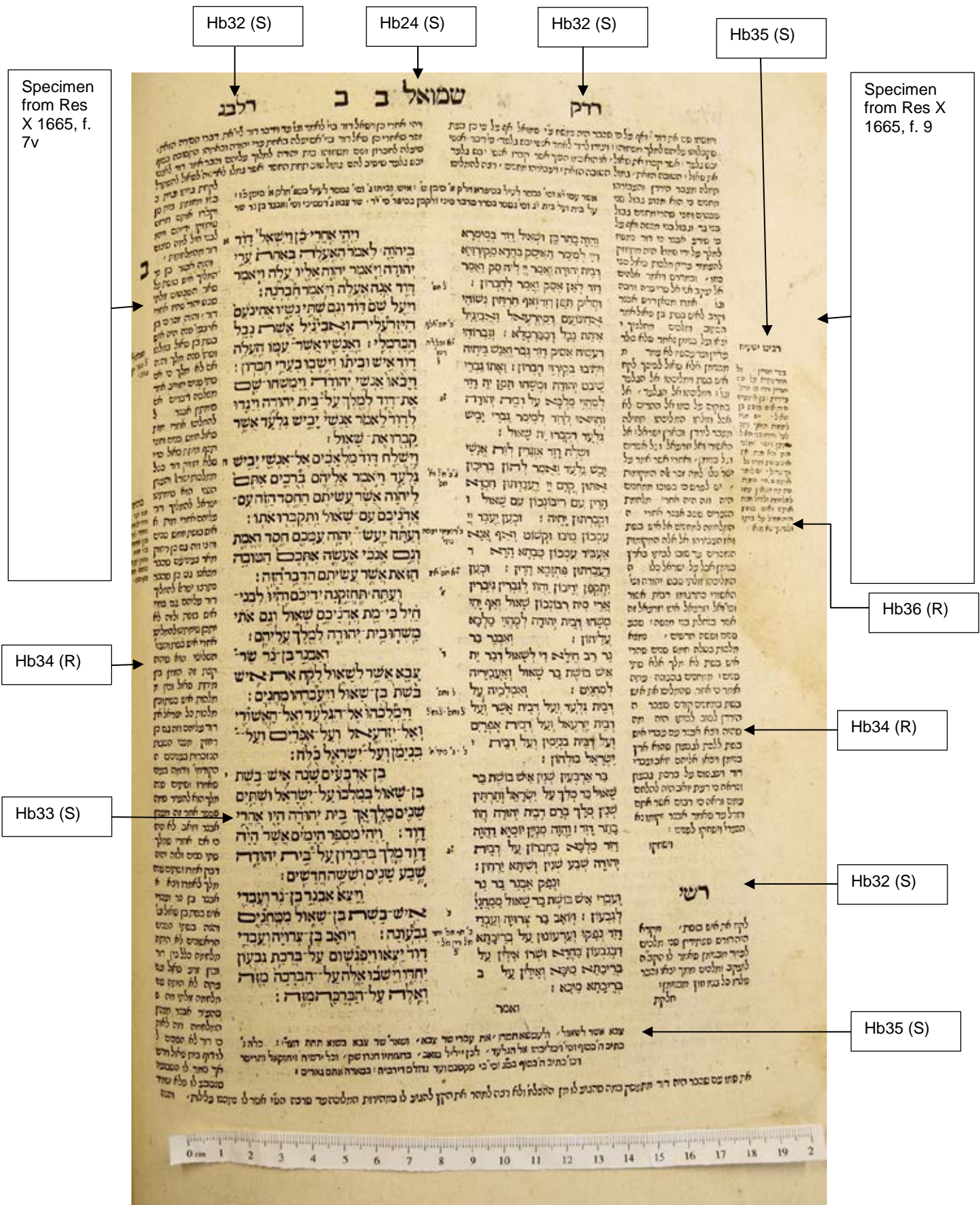

Fig. 4.41: Full Page from Bomberg *Biblia Rabbinica* of 1548, showing the sections reproduced on 1665 Folios 7v and 9 Reduced 70 per cent (Leo Baeck Library)

Hb33 (S)

Appears on: Rés-X-1665, folios 7, 7v, 9v, 20v
Size: Great Primer or Gros-romain
Type Classification: Square Sephardic pointed and unpointed
Measurements: x-height of 3 mm; 20:115 (vocalized) (Kalman = 118 mm)
Date of creation: Unknown
Punchcutter: Unknown
Materials preserved: None
Type Specimens: Le Bé, Rés. X 1665, f. 4; Omont, 1887, 7
First occurrence: *Pentateuch*, Venice, Bomberg, 1525-33

This is the main text font used in Bomberg's Third Rabbinic Bible and a very successful one, judging from the number of times it appeared in Venetian imprints during the 1540s. It is labelled type B in Ruth Kalman's study of the Bomberg books, which she says first appeared in 1520 and is to be found in at least ten Bomberg editions.⁶⁴⁰

This is not one of the Bomberg typefaces that made its way into the Plantin repertoire after the formation of the 'compagnie dimprimerie' in 1563, but judging from the evidence, it was used by other printers in Venice.⁶⁴¹ In size, it is slightly larger than Le Bé's vocalized Square Sephardic – Hb11(S) – which Vervliet gives as Great Primer or Gros-Romain in size. It could well have served as a model for Le Bé, when he cut his Hb11(S). The Bomberg is much heavier, blacker in colour, with less differentiation between the thick and thin strokes. In this regard, it resembles Raphael Frank's Frank-Rühl typeface of 1908, which may have been based on this model. Frank described the Bomberg Hebrews – most probably Le Bé's specimen on 1665 folio 17 – as being 'bewundernswert in ihrer Vollendung' and that contemporary Rabbis and authors remarked as 'ein Zusatz, der nur dem Namen jüdischer Grosser und verdienter Männer beigefügt wurde'.⁶⁴² It is this model of Hebrew typefaces, based on the Soncino and Bomberg Hebrews, and not those typefaces cut by Le Bé, which has predominated even until today. Raphael Frank's Frank-Rühl is still the preferred choice for setting text in Israeli publishing.

⁶⁴⁰ Kalman, *The Bookcraft of Daniel Bomberg's Press*, pp. 97-98

⁶⁴¹ A possible use of this type was found in an edition of Robert Bellarmine's *Institutiones linguae Hebraicae*, printed by Vidua & Moretus in Antwerp in 1596. See example on page 272. The use of vowels and cantillation marks, the use of the *litterae dilatabiles*, and the common features in many of the letter forms raise question as to how this typeface might have made its way into the Plantin repertoire at this time.

⁶⁴² Frank, *Über Hebräische Typen und Schriftarten* The German text reads 'admirable in its perfection' and 'an addition that was only added to the names of great and deserving Jewish men'.

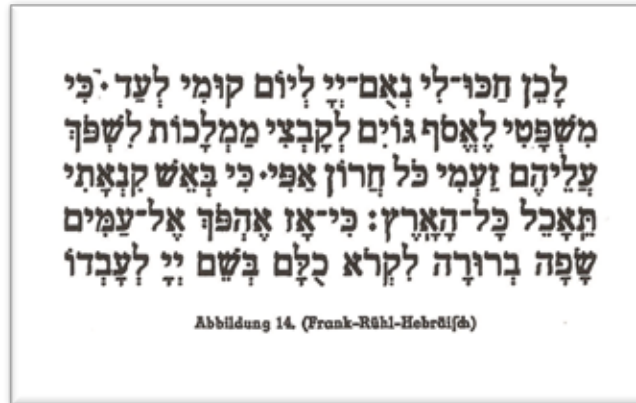

Fig. 4.42: Raphael Frank's Frank-Rühl specimen (From *Über Hebräische Typen und Schriftarten* (Berlin: Schriftgiesserei H. Berthold Abt. Privatdrucke, 1926, p. 27)

The termination on the middle stroke of the shin points to the left, which is not a characteristic of Le Bé's typefaces, and the junction of the descender and horizontal stroke of the lamed is very nearly a right angle. There is evidence in the Bomberg editions that the lamed was kerned and cut off manually to allow room for the vowels above as can be seen on lines 3, 12 and 16 in figure 4.43. The extended final mem has rounded not square corners. It is worth noting the circumcellus, which is used as a *signe de renvoi* to indicate variant spellings in the margin as for example in lines 4, 8, 16 and 17 in the Bomberg third Rabbinic Bible 1548 specimen.⁶⁴³



Fig. 4.43: Hb33 (S) Assembled alphabet from Bomberg third *Rabbinic Bible* 1548 Actual size (Leo Baeck Library)



Fig. 4.44: Hb33 (S) Assembled alphabet from Bomberg third *Rabbinic Bible* 1548 enlarged to x-height of 6.4 mm (Leo Baeck Library)

⁶⁴³ See Ginsburg, *Introduction to the Massoretico-critical edition of the Hebrew Bible*, p. 936 for discussion of *Keri* vs *Ketiv* spellings (i.e. read vs written).

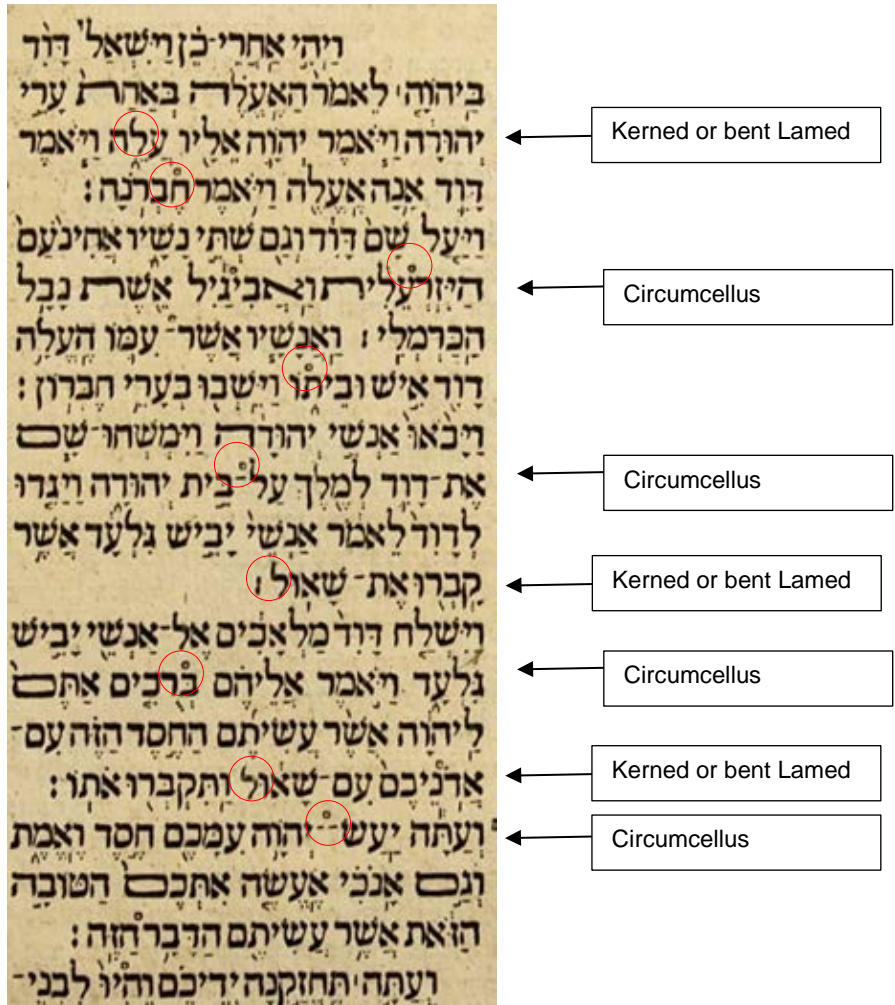

Fig. 4.45: Hb33 (S) Specimen of 20 lines from Bomberg third *Rabbinic Bible* 1548 Actual size (Leo Baeck Library)



Fig. 4.46: Page from Robert Bellarmine, *Institutiones linguae Hebraicae*, Vidua & Moretus, Antwerp, 1596 showing possible use of Hb33 (S). Actual size (Freimann Collection of the University of Frankfurt)

Attributions for this typeface in printed editions:

- *Babylonian Talmud - Masechet Makkot*, Venice, Bomberg, 1520 (Kalman)
- *Babylonian Talmud - Masechet Sota*, Venice, Bomberg, 1520 (Kalman)
- *Babylonian Talmud - Masechet Horayot*, Venice, Bomberg, 1521 (Kalman)
- *Pirkei Avot*, Venice, Bomberg, 1521 (Kalman)
- *Babylonian Talmud - Masechet Nedarim*, Venice, Bomberg, 1522 (Kalman)
- *Pentateuch (Tanach)*, Venice, Bomberg, 1524-26 (Kalman)
- *Pentateuch*, Venice, Bomberg, 1525-33
- *Babylonian Talmud - Masechet Keritut*, Venice, Bomberg, 1528 (Kalman)
- *Recognitio veteris Testamentis veritatem*, Venice, Aldus, 1529
- *B'eurim al Perush Rashi*, Venice, Giustiniani, 1545
- *Sefer Michlol*, Venice, Bomberg, 1545 (Kalman)
- *Even Bohan*, Venice, Adelkind, 1546
- *Pesikta Zutarta*, Venice, Bomberg, 1546
- *Sefer Dikdukim*, Venice, Bomberg, 1546 (Kalman)
- *Mirpe Lashon veDarkhei Na'im*, Bomberg, Venice, 1546 (Kalman)
- *Sefer Igeret HaKodesh*, Rome, Isaac de Lattes, Benjamin d'Arignano and Antonio Blado, 1546?
- *She'elot uTsehuvot Rabeinu Nissim Girondi*, Rome, Isaac de Lattes, Benjamin d'Arignano and Antonio Blado, 1546?
- *Sefer Agur*, Venice, Giustiniani, 1546/7
- *Sefer HaShorashim*, Venice, Giustiniani, 1547
- *Sefer Ha Shorashim*, Venice, Giustiniani, 1547
- *Sefer Sha'arei Dura*, Venice, Parenzo, 1547
- *Sefer Sha'ar Hashamayin*, Venice, Parenzo, 1547
- *Sefer HaKuzari*, Venice, Parenzo, 1547
- *Mishnayot MiSeder Nashim*, Venice, Querini, 1548
- *Mikraot Gedolot*, Venice, Bomberg, 1548
- Robert Bellarmine, *Institutiones linguae Hebraicae*, Antwerp, Vidua & Moretus, 1596?

Hb34 (R)

Appears on: Rés-X-1665, folios 7, 7v, 8, 8v, 9, 9v, 21v

Size: English or Saint-Augustin

Type Classification: Rashi Script unpointed

Measurements: x-height of 2 mm; 20:86

Date of creation: Unknown

Punchcutter: Unknown

Materials preserved: MPM, MA 82c

Type Specimens: Le Bé, Rés. X 1665, folios 7, 7v, 8, 8v, 9, 9v, 21v; Omont, 1887, 6; Index Characterum, 1657, folio A3, Plantin Specimen c. 1585 (Cursive sur la petite Augustine), Harry Carter, *Essai de Fonte*, 82;

Literature: Fuks, *Hebrew Typography in the Northern Netherlands*

First occurrence: *Sefer Ketuvim im HaTargum*, Venice, Bomberg, 1516-17?

Le Bé identifies this typeface in his annotation on Folio 7 of Rés-X-1665 as a ‘glose des Bombergues de Venise’, and once again on folio 7v of the same document as a ‘glose, impression des Bombergues de Venise’. Finally on folio 21v he identifies the Glose as a ‘petite glose dont sont faites des additions à la grand Bible des Bombergues de Venise telle quelle’. There is little doubt that this typeface was one of the first Hebrews cut at the beginning of Bomberg’s activities in Venice and used quite commonly both by Bomberg and other printers in Venice, as well as outside of Italy.

It was also one of the Hebrew founts brought back to Antwerp after Christophe Plantin’s return from Venice and was used by Plantin from 1566. It first appears in the Inventory of 1572, together with 14 other founts described as ‘et toutes les matrices de l’Hebrieu et Syriac tant creues que justifies, qui sont ensemble en vne boîte et chez Plantin’, and later in the 1590 Leiden Inventory, where it is probably described as *Coronelle ou petit Hebrieu*.⁶⁴⁴ The Plantin Moretus Museum holds 33 matrices (MA 82c). The two specimens below are from proofs in the MPM archives and from a set of proofs cast by Harry Carter in 1954.⁶⁴⁵ The Carter specimen mixes MA 82c and MA 164a, a *Vrai texte Hebreu*, dated to the sixteenth century without any attribution.⁶⁴⁶

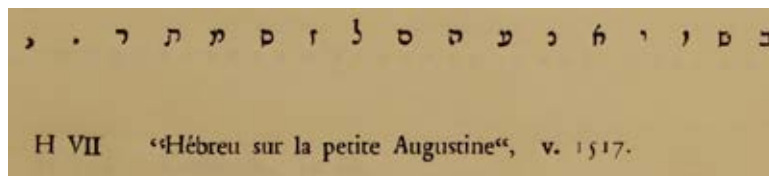

Fig. 4.47: Hb34 (R) From the *Catalogus Letterbeelden Proeven* (Museum Plantin-Moretus/Prentenkabinet)

⁶⁴⁴ Parker, Melis, and Vervliet, *Typographica Plantiniana II*, pp. 35, 45, 96

⁶⁴⁵ Harry Carter, *Essai de fonte dans les matrices conservées au Musée Plantin-Moretus*, (Oxford Printed for private circulation at the University Press 1954)

⁶⁴⁶ Plantin-Moretus Museum, *Inventaris van de stempels en matrijzen van het Museum Plantin-Moretus. Inventory of the Plantin-Moretus Museum punches and matrices. Engff. viii. 170.* Antwerpen, 1960), p. 112



Fig. 4.48: Hb34 (R) From the Specimen Types from Matrices at the Plantin-Moretus Museum, 1954, p. 7

Fuks called this Rashi as 'Raph. Ital. 1' and identified it as coming from the printing material Plantin brought with him to Antwerp, 'including eight different Hebrew founts'. It was used in two of the Leiden imprint examined for this thesis.

The key identifying factors in this Rashi type are the final nun, which has a distinctive right-facing termination and the lamed where the termination to the ascender has an angled stroke. The typeface as whole is very vertical in stress.



Fig. 4.49: Hb34 (R) Assembled alphabet from 1665 folio 8. Actual size



Fig. 4.50: Hb34 (R) Assembled alphabet from 1665 folio 8. Enlarged about 200%



Fig. 4.51: Hb34 (R) Specimen of 20 lines from 1665 folio 8. Actual size

Attributions for this typeface in printed editions:

- *Sefer Ketuvim im HaTargum*, Venice, Bomberg, 1516-17
- *Teshuvot*, Venice, Bomberg, 1519
- *Babylonian Talmud*, Venice, Bomberg, 1520
- *Talmud*, Venice, Bomberg, 1520-23
- *Sefer Dikduk*, Venice, Bomberg, 1523
- *Pentateuch*, Venice, Bomberg, 1525-33
- *HaMeturgeman*, Isny Fagius, 1541
- *Bible*, Venice, Bomberg, 1544
- *Sefer Michlol*, Venice, Bomberg and Adelkind, 1545
- *Rabbenu Bahya*, Venice, Bomberg, 1546
- *Even Bohan*, Venice, Adelkind, 1546
- *Pesikta Zutarta*, Venice, Bomberg, 1546
- *Sefer Igeret HaKodesh*, Rome, Isaac de Lattes and Benjamin d'Arignano, and Antonio Blado, 1546?
- *Sefer Agur*, Venice, Giustiniani, 1546/7
- *Rabbi Levi ben Gershom*, Venice, Bomberg, 1547
- *Mikraot Gedolot*, Venice, Bomberg, 1548
- *Ḥamishah ḥumshe Torah*, Antwerp, Plantin, 1566
- *Proverbia Salmonis*, Antwerp, Plantin, 1566
- *She'alot*, Venice, di Gara., 1574
- *Sefer Tehilim*, Antwerp, Plantin, 1581
- *Biblia Hebraica*, Antwerp, Plantin, 1582
- *Sefer Mikrae Kodesh*, Venice, Bragadin and Parenzo, 1586
- *Tsemach David*, Venice, Ioannis de Gara, 1586
- *Hinukh, hoc est Cathecheis*, Leiden, Officina Plantiniana apud Franciscum Raphelengium, 1591
- *Shenem asar Derashot*, Venice, di Gara and Bragadin, Parenzo, 1593
- *Shnem asar Derashot*, Venice, Di Gara, 1596
- *Pithu Sha'arim*, Basle, Waldkirch, 1599
- *Sefer Harukh*, Basle, Waldkirch, 1599
- *Machzor*, Venice, Bragadin and di Gara, 1599

- *Sefer Hakavanot*, Venice, Lorenzo Bragadin, 1620?
- *Sefer Tehilim, Psalterium*, Leiden, Raphelengius, 1615

Hb35 (S)

Appears on: Rés-X-1665, folios 7v, 8v, 9, 13v, 15v, 16, 16v, 17, 17v, 18, 18v, 20, 20v
Size: Textin des Bombergues, Mediane Hébreu (Long Primer or Petit-romain)
Type Classification: Square Sephardic pointed and unpointed
Measurements: x-height of 1.9 mm; 20:99 (vocalized); 20:86 (unvocalized)
Date of creation: Unknown
Punchcutter: Unknown
Materials preserved: MPM Augustine vieille Hebreu (MA164b) Mediane Hébreu; MA164c Double Augustine Hebreu vowels, intonations
Type Specimens: Le Bé, Rés. X 1665, f. 4; Omont, 1887, 6; Plantin's 1567 *Index Characterum*, Folio A3 (No. 20), Plantin's c. 1585 Folio Specimen No. 78 (Sur la Garamonde & Bible)?
Literature: Parker/Melis/Vervliet 1960, p. 133, *Inventaris van de stempels en matrijzen van het Museum Plantin-Moretus*, 1960, p. 117
First occurrence: *Talmud*, Venice, Bomberg, 1520-23?

This Bomberg Square Sephardic raises a number of interesting questions.

There is a set of 29 strikes (MA 164b) in the Plantin Moretus Archives which also includes 'a piece of a broken punch'.⁶⁴⁷ There is also a set of 24 strikes and 2 matrices in MA164c, which are mostly cantillation marks. The comments on these strikes notes that 'two matrices are from MA34 with which they appear in c. 1580 Specimen and also probably from the 1567 *Index Characterum*'. The comments continue that 'the matrices are not completely justified, and they fit punches from ST51 and must originally have been part of this set'.⁶⁴⁸ MA 164c is attributed to Hand A, an early or mid-sixteenth-century punchcutter, and notes that 'two of the faces for which his punches were used (No. 195, 205) are Hebrews connected with the Bombergs'.⁶⁴⁹ Neither of these two sets is listed in any of the Plantin inventories.⁶⁵⁰

It is extremely difficult to attribute precisely separate punches or matrices of vowels or cantillation marks, but there appears to be a strong likelihood in this case that MA164b and MA164c were intended to be used together. The Atnach or Etnachta (🕒) on the bottom line of MA164c is similar in size and style for example to the same sign in the bottom line of 1665 folio 16.

Did these strikes come to Antwerp with Bomberg, or were they acquired by some other means? Why were they never justified, hence not used in the Plantin oeuvre? Yet it is worth noting that it is precisely this typeface that Plantin sent to Le Bé as a specimen of the type of letter that he wanted Le Bé to cut for him.⁶⁵¹ Harry Carter noted that this typeface 'is one that had been used in Venice by Daniel Bomberg and, no doubt, brought into the stock of the company headed by Plantin when Cornelius

⁶⁴⁷ *Ibid.*, p. 116

⁶⁴⁸ Plantin-Moretus., *Inventaris van de stempels en matrijzen van het Museum Plantin-Moretus. Inventory of the Plantin-Moretus Museum punches and matrices. Eng.*, p. 111

⁶⁴⁹ *Ibid.*, p. 156

⁶⁵⁰ Parker, Melis, and Vervliet, '*Typographica Plantiniana II*', p. 133

⁶⁵¹ Res X 1665, f. 16v. This request is undated, and Carter writes that 'it is not possible to tell the date of the request'.

van Bomberghe joined it in 1563. Le Bé put several specimen-pages of this type into his albums; but he did not name it'. He concludes that 'it must therefore have been one of Daniel Bomberg's types'.⁶⁵² If we accept Carter's thesis as to its origins, then it remains to ask why only one possible specimen of this typeface was found in any of the Plantin editions examined for this thesis.⁶⁵³ One hypothesis is that Plantin never found a wider applicable use for it in his Hebrew editions, or perhaps that it did not find favour with him, hence the reason why he asked Le Bé to cut him a newer version. Le Bé's annotation on this specimen indicates that he was not able to fulfil Plantin's request, as he 'n'euz lors loisir de faire'. Yet there is little doubt that the reason behind Plantin's request was that he wanted a small pointed typeface for the text of one of his Hebrew Biblical editions, such as the 16mo *Biblia Hebraica* which he printed in 1576 and 1580/81, as he asked Le Bé to cut him a type with a full complement of vowels, cantillation marks and extended characters.

Harry Carter also draws attention to the similarity of the design to the types attributed to Jean Arnoul dit le Picard le Jeune. The early appearance of this typeface in the Bomberg editions would cast doubt on this idea, as Arnoul's dates of activity are much later (i.e. 1539 to 1545).⁶⁵⁴ Hb35 (S) is in fact similar to other attributed Bomberg typefaces in the Le Bé documents,⁶⁵⁵ and thus the most logical conclusion is that the same punchcutter was responsible for all of them. Harry Carter also writes that this typeface is shown as a '[Hebrieu] Sur la Garamonde et Bible' in the Plantin Folio Specimen of 'about 1579', which is in fact number 78 in the c. 1585 specimen.⁶⁵⁶ The 1567 *Index Characterum* also contains a specimen on folio A3 which is attributed to the same Bomberg typeface. Whereas the style characteristics in these specimens are similar to Hb35 (S), the x-heights are not the same.

Le Bé identifies it clearly as a 'textin des Bombergues' (1665 f. 9) and indeed it is found in various Bomberg editions, as well as many others. 'Textin' is not a French name for a type size, thus it is most likely that Le Bé was referring to the Italian size 'Testino', which is equivalent to the English Brevier or French Petit-Texte. Mediane would be the Dutch Mediaan, here equivalent to Cicero. The x-height of Hb35 (S) is 2 mm, yet in Vervliet's *Conspectus*, the closest equivalent is Long Primer or Petit-Roman. As we are left with a confusion of possible sizes, it appears best to stick with Le Bé on this typeface and call it a *Textin*.⁶⁵⁷

The key recognition factor for this typeface, where it occurs, is the aleph/lamed ligature, with its vertical upright stroke, distinctive 45 degree straight bottom stroke

⁶⁵² Carter, 'A Message from Plantin to Guillaume Le Bé', p. 60

⁶⁵³ The identification of Hb35 (S) in the 1573 *Plantin Hamishah Humshe* Torah is uncertain, but plausible. This is the 1573 Octavo Hebrew Bible, No. 652 in Voet and Voet-Grisolle, *The Plantin Press, 1555-1589: a bibliography of the works printed and published by Christopher Plantin at Antwerp and Leiden*, pp. 329-330

⁶⁵⁴ Vervliet, *French Renaissance Printing Types: A Conspectus*, p. 41

⁶⁵⁵ For example Heb/SS/37 and Hb37 (S)

⁶⁵⁶ Dreyfus, *Type Specimen Facsimiles II Nos 16-18*, pp. 2, 11

⁶⁵⁷ See Giuseppina Zappella, *Il libro antico a stampa (Parte Prima)* (Milano: Editrice Bibliografica, 2001), pp. 161-163 and Vervliet, *French Renaissance Printing Types: A Conspectus*, pp. 52-53

and curved side stroke. It can be seen on the bottom line of the Plantin Moretus Augustine vieille Hebreu specimen and in the Giustiniani 1548 specimen. The Lamed is also distinctive with the vertical ascender and large termination flag, and finally the Tsadde has a straight angled stroke which meets the base stroke in a sharp angle.

The specimens on folios 17, 17v, 18, 18v are cropped pages 40 and 41 (*Tractate Demai*) from the *Jerusalem Talmud* (Talmud Yerushalmi) printed by Daniel Bomberg in Venice in 1523.⁶⁵⁸ The lower specimen on folio 16v is also from the Bomberg *Jerusalem Talmud*, whereas the upper specimen is most probably from the Ben Asher *Pentateuch* printed by Bomberg in 1546, and 'is a commentary on Gen. 25: 29-34'.⁶⁵⁹ As with the Bomberg *Biblia Rabbinica* of 1548, the leaves are bound into the album, which explains the loss of text in the middle sections. There are no annotations by Le Bé on these specimens, but as they follow the specimen sent by Plantin (Folio 16v), one may assume that Le Bé was aware of the common origins of these typefaces.

The engraved opening word in the Bomberg *Jerusalem Talmud* is of interest. This is not technically a typeface cast in a hand mould, but characters engraved in wood. They are referred to in French as 'lettres grises' or 'lettres fleuries'. Wolf notes the first appearance of this term in 1550 in Paris.⁶⁶⁰ This was a very common practice in Hebrew manuscript and later book production, and was no doubt no influenced by the type of highly decorated wood engraving introduced by Geoffrey Tory.⁶⁶¹

The distribution of Hb35 (S) shows a wide usage, predominantly Venetian in the sixteenth and seventeenth centuries, but was also found in the 1629 edition of *Behinat HaOlam/L'Examen du Monde*, printed by Jean Lacquerhay in Paris.



Fig. 4.52: Hb35 (S) Assembled alphabet from the Le Bé specimen and the Giustiniani *Halakhot Gedolot* 1548 Actual size (UCLSC, SR Mocatta Quarto 1548 H1)



Fig. 4.53: Hb35 (S) Assembled alphabet from Le Bé specimen and Giustiniani *Halakhot Gedolot* 1548 Enlarged 1.5x (UCLSC, SR Mocatta Quarto 1548 H1)

⁶⁵⁸ Folio נכ verso, page 22 of <http://aleph.nli.org.il/nnl/dig/books/bk001936038.html>.

⁶⁵⁹ Wytze Gerbens Hellinga, Gerrit Willem Ovink, and D. A. S. Reid, *Copy and Print in the Netherlands. An atlas of historical bibliography ... With introductory essays by H. de la Fontaine Verwey and G. W. Ovink. (Translator, D. A. S. Reid.) [With plates.]* (Amsterdam: Federatie der Werkgeversorganisatiën in het Boekdrukkersbedrijf, 1962), p. 178

⁶⁶⁰ Wolf, *Terminologische Untersuchungen zur Einführung des Buchdrucks im französischen Sprachgebiet*, p. 64

⁶⁶¹ Sirat and De Lange, *Hebrew Manuscripts*, p. 148. See also Norma Levarie, *The Art & History of Books* (New York: J.H. Heineman/Da Capo Paperback, 1968), p. 190

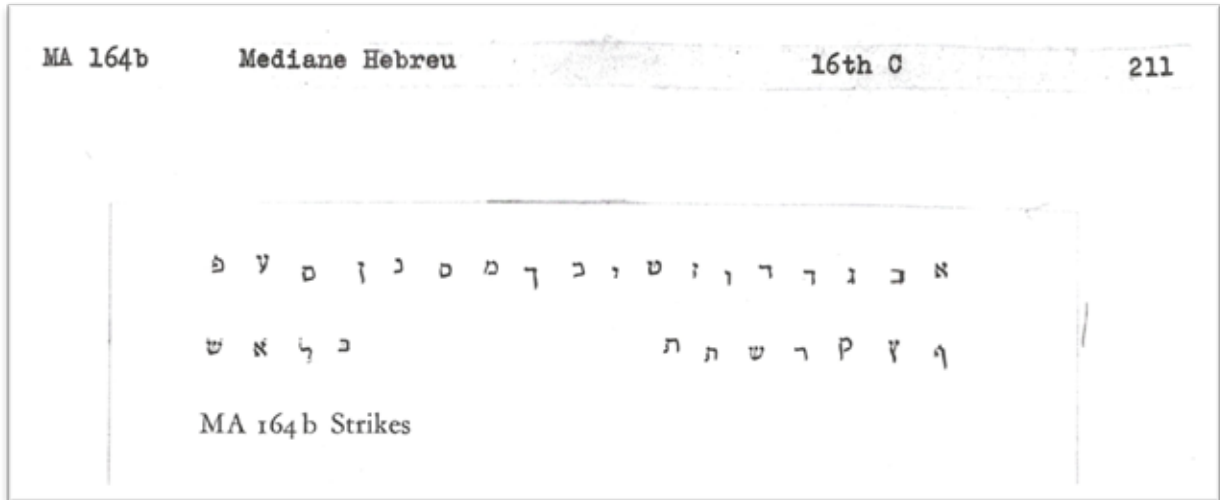

Fig. 4.54: MA 164b strikes Actual Size (Museum Plantin-Moretus/Prentenkabinet)

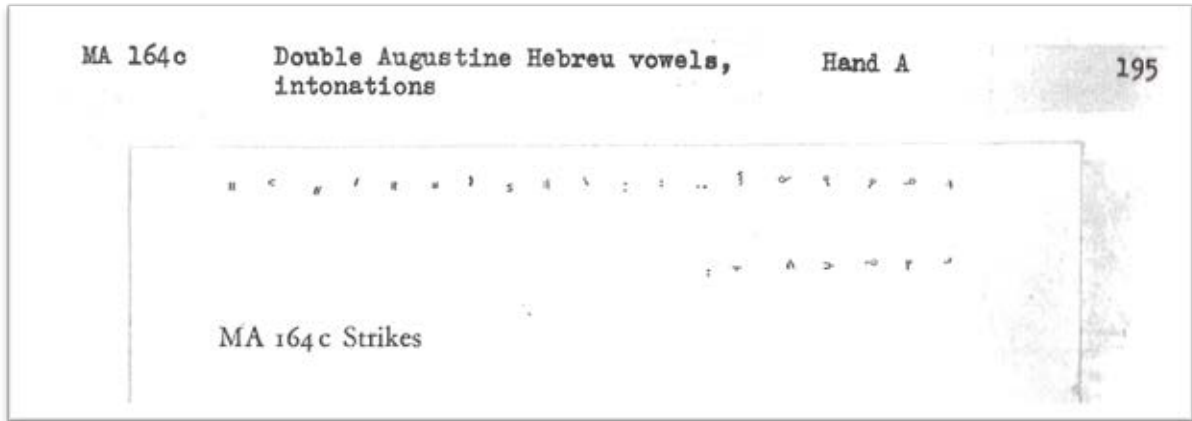

Fig. 4.55: MA 164c strikes Actual Size (Museum Plantin-Moretus/Prentenkabinet)

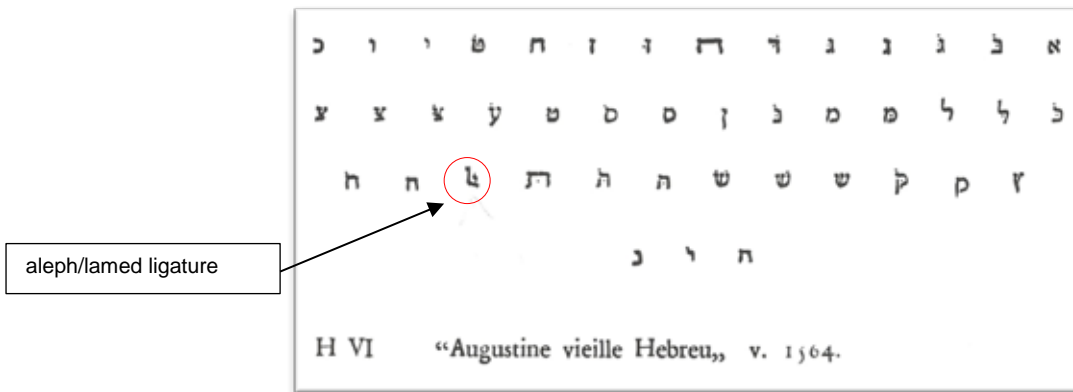

Fig. 4.56: Hb35 (S) Proofs from strikes Actual Size (Museum Plantin-Moretus/Prentenkabinet)



Fig. 4.57: Hb35 (S) as used in 1548 by Giustiniani (UCL/SC, SR Mocatta Quarto H1)



Fig. 4.58: Hb35 (S) from 1665 folio 16

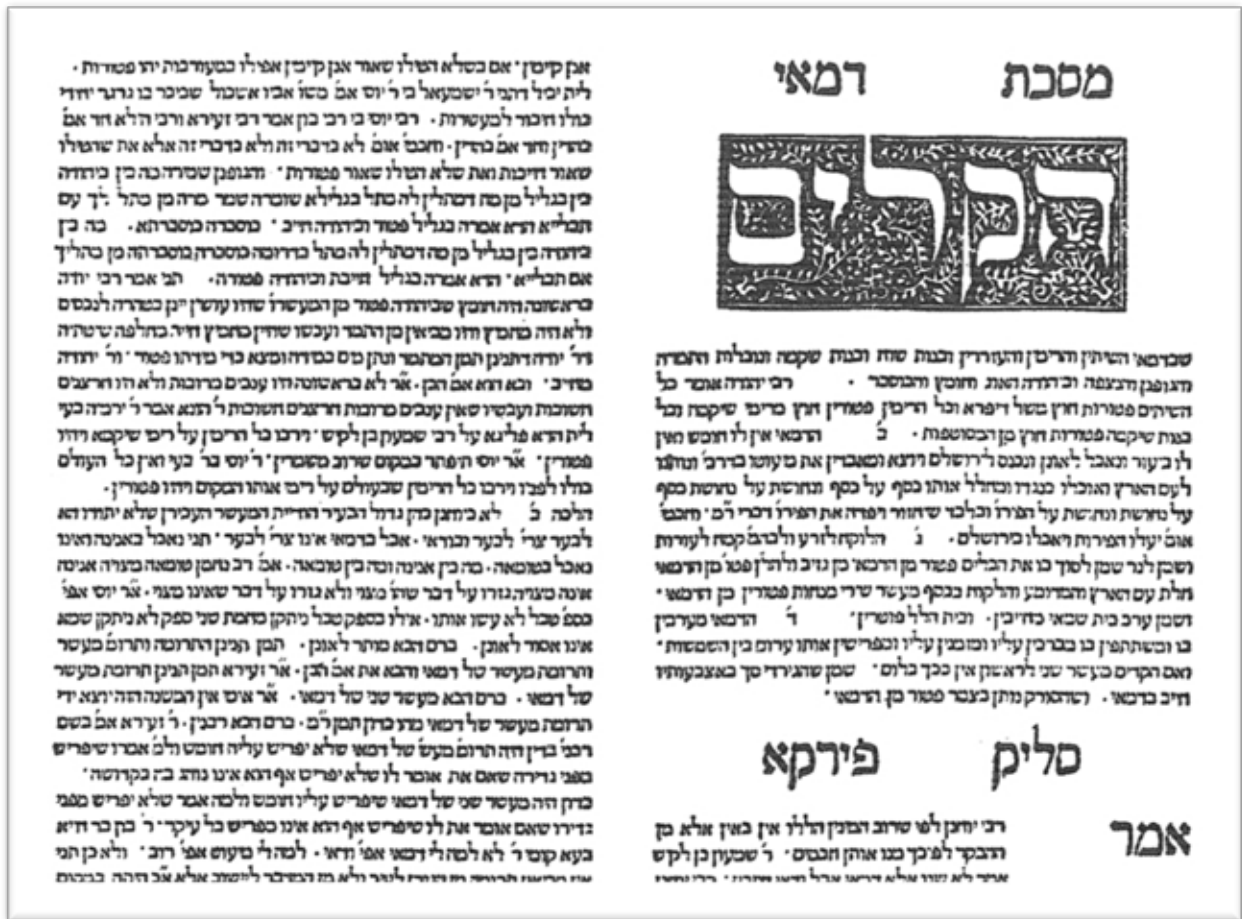

Fig. 4.59: Bomberg Jerusalem *Talmud*, 1523, top part of page 41, showing folios 17 and 17v from Res-X 1665. (Reduced 90 per cent) Note the example of *Lettre grise* in the right-hand column.

Attributions for this typeface in printed editions:

- *Talmud*, Venice, Bomberg, 1520-23
- *Babylonian Talmud*, Venice, Bomberg, 1520
- *Peculium Abrae*, Venice, Bomberg, 1523
- *Talmud Yersushalmi*, Venice, Bomberg, 1523
- *Perush HaTorah*, Venice, Di Gara/Adelkind, 1544
- *Perush Ba'al HaTurim al HaTorah*, Venice, Giovanni dei Farri and Cornelio Adelkind, 1544
- *Be'ur al HaTorah*, Venice, Giustiniani, 1545
- *Midrash Rabot*, Venice, Giustiniani, 1545
- *Be'ur al HaTorah*, Venice, Giustiniani, 1545
- *Seder Olam Raba*, Venice, Giustiniani, 1545
- *Igrot leha-ma'or ha-gadol, ha-ner ha-ma'aravi*, Venice, Giustiniani, 1545
- *Sefer Michlol*, Venice, Bomberg and Adelkind, 1545

- *Avodat Halevi*, Venice, Giustiniani, 1545/46
- *Even Bohan*, Venice, Adelkind, 1546
- *Be'ur al ha Torah*, Venice, Giustiniani, 1546
- *Rabbenu Bahya*, Venice, Bomberg, 1546
- *Otiot shel Rabi Akiba*, Venice, Giustiniani, 1546
- *Even Bohan*, Venice, Adelkind, 1546
- *Pesikta Zutarta*, Venice, Bomberg, 1546
- *Sefer Agur*, Venice, Giustiniani, 1546-7
- *Rabbi Levi ben Gershom*, Venice, Bomberg, 1547
- *Mikraot Gedolot*, Venice, Bomberg, 1548
- *Halakhot Gedolot*, Venice, Giustiniani, 1548
- *Sefer Mashal HaKadmoni*, Venice, Parenzo, 1550?
- *Sefer Birkat Avraham*, Venice, Bragadin, 1552
- *Sefer Hazut Kashah*, Sabionetta, Foa, 1552
- *Sefer Arba'ah Turim*, Cremona, Conti, 1558?
- *Sefer Tanhuma*, Mantua, Rufinelli, 1563
- *Rabenu Bahye*, Venice, di Cavalli, 1566
- David ben Joseph Abudarham, *Leperush Tefilot HaShana*, Venice, Di Cavalli, 1566
- *Shulhan Arukh*, Venice, di Cavalli, 1567
- *Sefer Kol Bo*, Venice, di Cavalli, 1567
- *Bible*, Antwerp, Plantin, 1573
- Yosé ben Halaphta, *Seder 'Olam rabba: Seder 'Olam zuta*, Basle, Ambrosius Frobenius, 1580
- Abraham Zacuto, *Sefer Yuchasin*, Cracow, Prostitz, 1580-1?
- Koppelman, *Sefer Misle Su'alim*, Freiburg im Breisgau, Zifroni, 1583
- Gerondi, *Sefer Chaje Olam*, Freiburg im Breisgau, 1583
- Benjamin Tudela, *Masa'ot shel Rabi Benjamin*, Freiburg im Breisgau, Zifroni, 1583?
- Koppelman, *Ohel Ya'akov*, Freiburg im Breisgau, Zifroni, 1583/84
- *Sefer Toledot Aharon*, Freiburg im Breisgau, Zifroni, 1584
- Koppelman, *Targum shel Chamesh Megilot*, Freiburg im Breisgau, Zifroni, 1584

- *Sefer Toledot Aharon*, Venice, Bragadin, 1591
- *Sefer Tiferet Israel*, Venice, Zanetti, 1599
- *Machzor*, Venice, Bragadin and di Gara, 1599
- *Bible/Pentateuch*, Bragadin, Venice, 1590
- Judah Aryeh Leone da Modena (?), *Tzemach Tzadik*, Venice, Zanetti, 1600
- *Sefer Urim ve Tumin*, Venice, Zanetti, 1603
- *Sefer Arba'ah Turim*, Hanau, Hans Jakob Henne, 1610
- *Haggadah*, Daniel Zifroni, Venice, 1620
- *Behinat HaOlam*, Laqueray, Paris, 1629

Hb36 (R)

Appears on: Rés-X-1665, folios 7v, 21v
Size: Petite Glose (Garamonde or Petit Romain)
Type Classification: Rashi Script unpointed
Measurements: x-height of 1.2 mm; 20:55
Date of creation: Unknown
Punchcutter: Unknown (Strikes produced by François Guyot in Antwerp in 1565)
Materials preserved: MPM MA135c
Type Specimens: Le Bé, Rés. X 1665, 7v, 21v; Omont, 1887, 7
First occurrence: Unknown

This Rashi Script glose appears twice in Rés. X 1665 and both are identified by Le Bé as coming from a Bomberg edition.⁶⁶² The first occurrence (in Folio 7v) is from the third Bomberg *Biblia Rabbinica* (*Mikraot Gedolot*) of 1548 and is used to provide commentary on individual words. The second occurrence (folio 21v) is in too small a specimen to identify precisely, but it looks very much like a part of the same Rabbinic Bible, but showing what is possibly a commentary by the Ba'al ha-Turim, a medieval rabbinic authority, known for his influential work on the halakha (Jewish law), the *Arba'ah Turim* ('Four Rows').

A set of 29 strikes to be found in the Plantin Moretus Museum and known as MA135c is identified as this typeface. It is found in three inventories. The first is in the 1572 inventory, where it was put together with 14 other matrices (et toutes les matrices de l'Hebrieu et Syriac tant creues que justifiées ...). In the second, the 1590 Leiden inventory, it is combined with MA135a and 135b (103 matrices in total) and labelled 'Cursives Hebraiques', and finally in the third, the 1652 inventory written by Balthasar II Moretus, where it is called 'Bybel Cursijf Hebreusch, onghejusteert'. In this last inventory, 38 matrices are noted, and it is not clear what the additional nine matrices would be. The strikes were struck by François Guyot in 1565, the Parisian-born punchcutter who was active in Antwerp from about 1539 to 1570, and was 'Plantin's regular type founder from 1558'.⁶⁶³ Guyot called these strikes a 'cleyn glost corsijf' and one may assume that he had in his possession the original Bomberg punches.⁶⁶⁴

This Rashi script was not used by Plantin in any of his Hebrew editions, and an examination of the strikes shows clearly that they were not justified, nor was the distance to the head of the matrix from the character baseline adjusted to make for a correct alignment in the mould. It was provisionally identified in two Roman Hebrew editions in 1546, printed by Isaac de Lattes and Benjamin d'Arignano, in collaboration with Antonio Blado: *Sefer Igeret HaKodesh* and *She'elot uTsehuvot Rabeinu Nissim Girondi*. The trail of this Bomberg type from Venice to Rome has yet to be clarified.

⁶⁶² 'Petite glose dont sont faictes des additions a la grand Bible des Bombergues de Venise telle quelle.

⁶⁶³ Vervliet and Carter, *Sixteenth-century printing types of the Low Countries*, pp. 26-27

⁶⁶⁴ Parker, Melis, and Vervliet, *Typographica Plantiniana II*, pp. 48, 96, 118.



Fig. 4.60: MA135c Photograph of strikes Actual size (Museum Plantin-Moretus/Prentenkabinet)

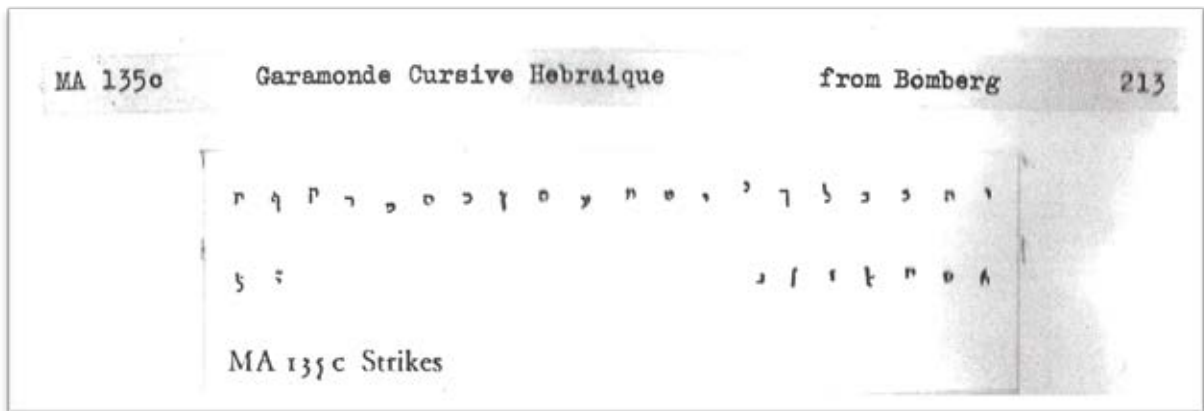

Fig. 4.61: Hb36 (R) From Inventaris van de stempels en matrijzen van het Museum Plantin-Moretus, 1960 (Museum Plantin-Moretus/Prentenkabinet)

This Rashi Script has the characteristic final nun and straight ascender of the lamed of other Bomberg Rashis. The Plantin Moretus specimens also show a distinctive final Tsadde where the descender curves slightly to the right.



Fig. 4.62: Hb36 (R) Partial assembled alphabet (Actual size) from Le Bé specimens



Fig. 4.63: Hb36 (R) Partial assembled alphabet (Enlarged 2x) from Le Bé specimens

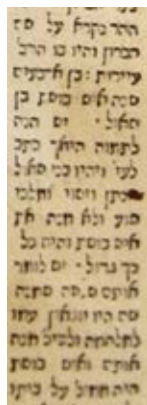

Fig. 4.64: Example of Hb36 (R) from Bomberg 1548 Third *Biblia Rabbinica* Actual size (Leo Baeck Library)

Hb37 (S)

Appears on: Rés-X-1665, folios 8, 8v, 9, 13v

Size: Moyenne (Petit texte)

Type Classification: Square Hebrew Sephardic pointed

Measurements: x-height of 2.3 mm; 20:115 (vocalized)

Date of creation: Unknown

Punchcutter: Unknown

Materials preserved: MPM, MA24 and ST56 (4 punches)

Type Specimens: Le Bé, Rés. X 1665, f. 4; Omont, 1887, 6; *Index Characterum* 1567, Folio A3 (No. 7 Ex Proverbiis Salomonis); Plantin's Folio specimen c. 1585 (No. 84) Sur le petit Texte

Literature: *Inventaris van de stempels en matrijzen van het Museum Plantin-Moretus*, pp. 114-115, 119; Parker, Melis, Vervliet, *Typographica Plantiniana II*, 1960, pp. 42; Fuks, *Hebrew Typography*, 1984, p. 12 (Raph. Sq. 5); *Type Specimen Facsimiles II*, p. 2

First occurrence: Bomberg, *Vetus Testamentum hebraice*, Venice, 1517, *Sefer Ketuvim im HaTargum*, Venice, Bomberg, 1516-17?

This is a well-documented and represented typeface, identified by Le Bé on folios 8, 9 and 13v as a ‘moyenne des Bombergues’. The previous use of this size has been discussed,⁶⁶⁵ but is called a Petit Texte (or also Kleine Text) in the 1572 Inventory, and ‘Cleyntext Hebreusch’ in the 1652 Inventory (pp. 35, 42, 114).⁶⁶⁶ In the Folio specimen of c. 1585 it is called ‘Sur le Petit Texte’.⁶⁶⁷ Fuks identifies it as Raph. Sq. 5 and writes that ‘it is the most commonly used Hebrew fount, both by Plantin in Antwerp and the firm in its Leiden days. Plantin first used it for his three Hebrew bible editions in 4to, 8vo and 16mo, all of which appeared in 1566’. He adds – and not correctly on the attributions – that they ‘were brought from Venice by Cornelis van Bomberghen, who started to work for Plantin in 1563. The types had been cut for Daniel van Bomberghen in Venice by Guillaume Le Bé’.⁶⁶⁸

Cornelis van Bomberghen was indeed a partner in the ‘compagnie d’Imprimerie’ founded in 1563, but his role was that of ‘comptable de association’ (accountant). Cornelis (or Corneille II) was an active supporter of the Protestant cause and was banished from the Spanish Netherlands in 1567.⁶⁶⁹ Le Bé makes no direct claim in the two documents to have cut this typeface, nor any other, for Bomberg. Fuks cites Omont, but this is clearly a misreading of Omont’s text.⁶⁷⁰

The specimen proofs found in the Museum Plantin Moretus are shown in the following pages and are inconsistent in the number of matrices shown. The actual number of matrices held is 90, including 10 which are marked as fitting the punches in ST56. These are part of what is labelled the ‘Hebrew Pool’ which comprises 18

⁶⁶⁵ See page 91 of this thesis.

⁶⁶⁶ Parker, Melis, and Vervliet, *Typographica Plantiniana II*, pp. 35, 42, 114

⁶⁶⁷ Dreyfus, *Type Specimen Facsimiles II Nos 16-18*, pp. 2, 11

⁶⁶⁸ Fuks and Fuks-Mansfeld, *Hebrew typography in the Northern Netherlands*, p. 12

⁶⁶⁹ van Ortroy, *Contribution à l’histoire des imprimeurs et des libraires belges établis à l’étranger*, p. 103. See also Bomberghen, *Généalogie de la famille van Bomberghen*, pp. 139-143

⁶⁷⁰ Fuks and Fuks-Mansfeld, *Hebrew typography in the Northern Netherlands*, p. 12

punches and one matrix.⁶⁷¹ Four of the punches, presumably the two versions of the extended characters, the final mem, the lamed and the heh, which can be seen in the matrices, are those produced by Robert Granjon. He was active in Antwerp for some seven years before his return to Paris in 1570, and the MPM archives record that Plantin paid him for producing these characters in January 1565.⁶⁷² The MPM example of MA24 shows a total of 90 characters including vowels and cantillation marks, whereas the specimen sheet HV shows only 75 characters, vowels and cantillation marks. Harry Carter's *Essai de fonte* shows 29 characters and no separate vowels, and confuses the direction of the aleph/lamed ligature.

It should be noted that the handwritten note in the MA24 box relates that ten of the matrices marked with a green stroke fit the punches in ST56. This may indicate replacement characters, as well as the additional extended characters, which were ordered by Plantin.

Hb37 (S) has several distinctive recognition characters, in addition to the size. The middle stroke of the aleph/lamed ligature meets the upright stroke at a right angle, and the smaller upright stroke is also at a right angle. The lamed has a slightly angled ascender with a distinct termination flag, and the shin has a vertical middle stroke joining midway on the bottom stroke. The final tsadde has the ascender angled to the right and the middle stroke of the tet almost touches the bottom stroke.

It is not possible to tell precisely from the struck matrices how the punches were cut, i.e. whether they were stepped or separate. A microscopic examination of the matrix for the shin shows double upper points, which could be a sign of a Portmanteau sort. The two upper points were most likely struck with the main character, yet the dagesh point in the centre shows clear signs of being finished by hand with some kind of file. The contours of the character also look like they were finished in the same way. Thus we have here a good example of a matrix formed partially by a combination of direct strike and hand finishing.

⁶⁷¹ Plantin-Moretus., *Inventaris van de stempels en matrijzen van het Museum Plantin-Moretus. Inventory of the Plantin-Moretus Museum punches and matrices. Eng.* , p. 119

⁶⁷² Vervliet and Carter, *Sixteenth-century printing types of the Low Countries*, p. 31. See also Parker, Melis, and Vervliet, *Typographica Plantiniana II*, p. 42



Fig. 4.65: Magnified photo of the matrix for shin in the MA24 (Museum Plantin-Moretus/Prentenkabinet)



Fig. 4.66: MA24 Full listing of 90 matrices Shows 90 matrices in total Actual size (Museum Plantin-Moretus/Prentenkabinet)



Fig. 4.67: HV Kleine Text) MA24 Full listing of 90 matrices (Actual size) Shows 75 matrices in total (Museum Plantin-Moretus/Prentenkabinet)

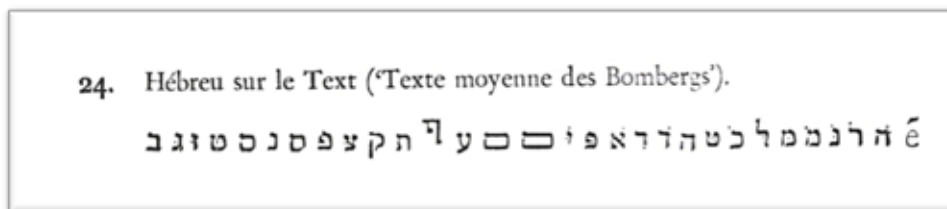

Fig. 4.68: From Harry Carter's Specimen types from Matrices at the Plantin-Moretus Museum, 1954 Actual size Shows 29 characters in total (Museum Plantin-Moretus/Prentenkabinet)



Fig. 4.69: MA24 showing complete matrices in their box. Reduced 80 per cent (Museum Plantin-Moretus/Prentenkabinet)



Fig. 4.70: Hb37 (S) Specimen 20 line setting from Bomberg *Sefer Ketuvim im HaTargum*, Venice 1516-17 (UCL/SC, SR Lewis Trust 5)

In the study of Bomberg's Hebrew editions, Ruth Kalman identifies Hb37 (S) as Type A Square and notes that it was found in 11 Bomberg editions, starting from 1514 until 1546, that is for the entire period of Bomberg's activity in Venice. She makes a note of three extended characters – the aleph, heh and tav – and three forms of the character lamed, but this is more likely to be due to broken or bent kerned ascenders than to differently cut characters.⁶⁷³ The specimens of Hb37 (S) on 1665 folios 8 and 8v are from the same edition, as they are printed back to back on the same sheet and bound into the album, not pasted. It is most likely that they are from the 1516 or the 1521 Bomberg Quarto Bible, as they contain only the Biblical text and the Haftarah of parashat *Va-era*, but the exact location has yet to be determined.⁶⁷⁴

The distribution of this fount as seen in the volumes examined for this thesis appears to be limited to Venice and the Netherlands. The trail of the Bomberg founts to Antwerp and Leiden via Plantin is clear enough, yet other printers may well have used it or indeed used it as a model for their own typefaces. This was the case in certain Hebrew editions by Jacob Marcaria in Riva di Trento in the 1550s and 1560s.

The high estimation with which the Bomberg Hebrew editions were held during the sixteenth century can be seen in the dialogue written by the Portuguese-born Jewish

⁶⁷³ Kalman, *The Bookcraft of Daniel Bomberg's Press*, pp. 93-94 (Ketav Merooba Aleph)

⁶⁷⁴ Ginsburg, *Introduction to the Massoretico-critical edition of the Hebrew Bible*, pp. 948-956. I am grateful to Mrs. Pauline Malkiel of the Valmadonna Library in London for clarification on this point.

scholar and writer Immanuel Aboab (c. 1555 – 1628).⁶⁷⁵ He wrote that ‘even that much is owed to Christophe Plantin, who printed with such clarity this Bible in the year 5326 (1565 or 1566), and not least is owed to Daniel Bomberg, whose types were used to print it, as can be seen from the authority on the title page’.⁶⁷⁶

It has to be said that these Bomberg types are somehow rougher and more crudely fashioned than those cut by Le Bé, but they nonetheless found favour with a wide public. This success can be partially attributed to the accuracy of the Bomberg Hebrew editions and the way in which Bomberg tailored his editions to his two most profitable markets: Jewish and Christian. He added certain features, such as adding additional Nekudot to make the volumes more readable to Christian students or printing his editions in smaller easier-to-handle formats. Bomberg’s reputation was well known north of the Alps, as can be seen in the comment by Nicolaus Cleynaerts⁶⁷⁷ and the records of Georg Spalatin, the superintendant of the ducal library in Wittenberg, who ‘made annual trips to purchase published Greek, Latin, and Hebrew books for universities on German lands’ and especially so from Bomberg. Bomberg also catered for the widely spread Jewish congregations in regions bordering the Mediterranean, and printed their Machzorim, as well as printing for example a volume of *Pesakim* (Rabbinical decisions or judgements) for the Venetian Rabbinate. Thus it can be said that the high approval and acceptance of his Hebrew types was allied in some way with the actual reputation of his editions.⁶⁷⁸

Attributions for this typeface in printed editions:

- *Sefer Ketuvim im HaTargum*, Venice, Bomberg, 1516-17
- *Pentateuch*, Venice, Bomberg, 1525-33
- *Sefer Dikduk*, Venice, Bomberg, 1523
- *Bible*, Venice, Bomberg, 1544
- *Kohelet/l’Ecclesiaste di Salome*, Venice, Ziletti, 1571
- *Iosuae Imperatoris Historia*, Antwerp, Plantin, 1574
- *Sefer Tehilim*, Antwerp, Plantin, 1581

⁶⁷⁵ He was the grandson of the noted fourteenth century Spanish scholar Isaac Aboab. See ‘Aboab’(<<http://www.jewishencyclopedia.com/articles/344-aboab>> [Accessed 14 March 2008]

⁶⁷⁶ Imanuel Aboab and Ischak Lopes, *Nomologia o Discursos legales*. Segunda edicion. Coregida y emendada por ... Ischak Lopes. (Amsterdam, 1727). The original Spanish reads: ‘Aun que se deve mucho à Christophoro Plantino, que imprimió con tanto cuydado esta Biblia en el año 5326 (1565 or 1566), no se deve menos à Daniel Bomberga, con cuyos moldes se hizo la estampa; y por su mandato, como se vé en el titolo’.

⁶⁷⁷ The Hebrew books which Bomberg prints in Venice are shipped by sea to Jews in all parts of the world, in Africa, Ethiopia, the Indies, Egypt and to other parts of the world’. Cited by Nielsen from Nicolaus Clenardus and Alphonse Roersch, *Correspondance de Nicolas Clénard. Publiée par Alphonse Roersch. Lat. & Fr* (Bruxelles: Palais des Académies, 1940)

⁶⁷⁸ For more detailed discussion of these issues see Nielsen, ‘Daniel van Bomberghen, a Bookman of Two Worlds’, in *The Hebrew book in early modern Italy*, ed. by Hacker and Shear (Philadelphia, Pa.: University of Pennsylvania Press, 2011), pp. 67-74

- *Biblia Hebraica*, Antwerp, Plantin, 1582
- *Hinukh hoc est Catechesis*, Leiden, Raphelengius, 1591
- *Pentateuch*, Venice, Bragadin and di Gara, 1597
- *Biblia Hebraica*, Leiden, Raphelengius, 1613
- *Sefer Tehilim*, Leiden, Raphelengius, 1615
- *Sefer Tehilim/Psalterium*, Leiden, Raphelengius, 1615
- *Samuelis libri duo*, Leiden, Le Maire, 1621
- *Samuelis libri duo*, Leiden, Johannes Le Maire, 1621
- *Grammatica Ebraea Generalis*, Leiden, Raphelengius and Le Maire, 1621
- *Samuelis libri duo*, Leiden, Johannes LeMaire, 1621
- *hoc est Arcanum punctationis revelatum*, Leiden, Le Maire, 1624

Hb38 (S)

Appears on: Rés-X-1665, folios 11vface, 11v revers, 15v,

Size: Petit texte

Type Classification: Square Hebrew Sephardic pointed

Measurements: x-height of 1.9 mm; 20:87 (vocalized)

Date of creation: Unknown

Punchcutter: Unknown engraver for the mint (Graveur de Monnaye et cachetz), Venice for Marco Antonio Giustiniani

Materials preserved: None

Type Specimens: Le Bé, Rés. X 1665, folios 11vface, 11v revers, 15v; Omont, 1887, 7;

Literature: None

First occurrence: *Machzor* (Daily Prayers), Venice, 1545

Le Bé attributes this typeface to a 'graveur de monnaye et cachetz', meaning an engraver of coinage and seals and adds that it was cut for the printer and publisher Marco Antonio Giustiniani. This attribution is of itself of interest, as it answers the question of how and by whom many of the unattributed typefaces in the Le Bé documents might have been cut. Engravers of coinage and medals are well known in late medieval and early modern Europe and, in the case of France, they were highly organised and controlled. The techniques involved in producing coinage and medallions would have been very similar to those involved in cutting and striking punches and matrices for type, and it would have been quite natural for craftsmen to move into the new crafts created by the invention of printing. As an example, the punchcutter Nicolas Jenson was a 'maître et tailleur de la monnaie de Tours' and was sent by Charles VII in 1458 to Mainz to learn the craft of printing by 'poinçons et carractères', and later established himself in Venice where he became celebrated for his Roman types.⁶⁷⁹ A further example is the Basle printer Johann Amerbach (1440 – 1513) who used the services of a Strasbourg goldsmith, Hans van Unkel, in the 1490s to produce punches and matrices.⁶⁸⁰

Le Bé also notes that this type is 'de Justinian' and it does appear in six Giustiniani editions in 1546 and 1547. Le Bé arrived in Venice towards the end of 1545 and his first type – Hb1(S) – is dated to this period. It may be that Hb38 (S) was commissioned and produced before Le Bé's arrival. In addition, Le Bé did not produce a similar-sized vocalised Square Sephardic until 1579 in Paris, which may point to his awareness of only cutting those Hebrews which were lacking in Venice. We also note that on occasion he was commissioned to cut a particular size, as with the request from Plantin.⁶⁸¹ This was the pattern of some of his types, notably those

⁶⁷⁹ Rondot and de La Tour, *Les Médailleurs et les Graveurs de monnaies, jetons et médailles en France*, pp. 15-16, 153-154. See also Alex W. White, 'Nicolas Jenson's Typographic Contributions' (2010) <<https://tdc.org/articles/nicolas-jensons-typographic-contributions/>> [Accessed 27 September 2012]]

⁶⁸⁰ Johannes Amerbach and Barbara C. Halporn, *The correspondence of Johann Amerbach: early printing in its social context, Recentiores: later Latin texts and contexts*. (Ann Arbor: University of Michigan Press, 2000), pp. 85-86

⁶⁸¹ 1665 f. 16v

produced for Giustiniani, Meir di Parenzo, Adrian Le Roy, Robert I Ballard and Christophe Plantin. Later in his life he appears to have cut typefaces for his own pleasure and not with a particular client in mind.

This typeface is somewhat condensed in its 'set', and this characteristic can be seen in the ayin and the aleph. As Biblical Hebrew does not allow for word breaks, the extended characters for the aleph, heh and final mem, and tav were also provided. Another recognition element is the shin, which has the termination flag on the middle stroke pointing left. This is certainly not seen in any of the Bomberg or Le Bé typefaces.



Fig. 4.71: Hb38 (S) Assembled alphabet from the Le Bé specimens (Actual size)



Fig. 4.72: Hb38 (S) Assembled alphabet from the Le Bé specimens (Enlarged 2x)



Fig. 4.73: Hb38 (S) Page from the 1546 Giustiniani Pentateuch (BL 1944b5)

The specimen in the Le Bé documents are from the 1546 Giustiniani Pentateuch (*Sha'ar bet H. he-hadash: ... Humash im Targum va-Hamesh megilot ve-Haftarot*), verses from Genesis 9:9-27 (Folio 11vface) and Genesis 8:13-22 and Genesis 9:1-8 (Folio 11v revers). Curiously, the copy in the British Library has the same Biblical

text, yet the side references appear on the right hand margin, the pagination mark is missing, and the catch line has been altered. These are indications of a re-impression, but only a comparison between multiple editions would provide a clue as to the printing order of the editions.

In addition to the Venetian imprints, Hb38 (S) was also found in Hebrew editions from Cracow and Geneva. The attributions are provisional, as the founts were poorly cast and thus irregular in their alignment, nonetheless many of the key recognition factors are the same.

In the course of the examination of the Hebrew editions for this thesis, there emerged a further three unattributed Hebrew founts. These unattributed founts have striking similarities with Hb38 (S) and a provisional conclusion is that these two types were cut by the same 'graveur de monnaie et cachetz' who cut Hb38 (S). The first fount is a 6 mm, and the second a 3 mm Square Sephardic and both appear without vowels. The third has an x-height of 2.5 mm and is pointed. They were found in the following editions, but are not found in either of the two Le Bé documents:

- Jeshua ben Joseph, *Sefer Halikhot Olam*, Venice, Adelkind and dei Farri, 1544 (BL 1956b19)
- Jacob ben Asher, *Perush HaTorah*, Venice, Adelkind and dei Farri, 1544 (BL 1984bb4)
- Joseph Albo, *Sefer Ikarim*, Venice, Giovanni dei Farri, 1544 (BL 1932e3)
- *Pirkei Rabi Eliezer*, Venice, Adelkind and dei Farri, 1544 (BL 1954)
- Isaac Abravanel, *Sefer Zevach Pesach*, Venice, Giustiniani, 1545 (BL 1974c1)
- *Seder Tefilot mi-khol ha-Shanah*, Venice, 1545 (BL 1973a19)
- *Sefer Rosh Emunah*, Venice, Giustiniani, 1545? [BL 1952d9 (5)]
- *Nachalat Avot*, Venice, Giustiniani, 1545 (BL 1952f5)
- *Machzor*, Venice, 1545? (BL 1973a19)
- *Sefer Agur*, Venice, Giustiniani, 1546/7 (Hebrewbooks.org)

The similarities of these unattributed Hebrews to Hb38 (S) are the ayin in both the 6 and 3 mm founts with the same condensed set. The shin shows the same left pointing flag on the middle stroke. Likewise, the tet, lamed, tsadde and final nun are similar.



Fig. 4.74: 6 mm assembled unattributed alphabet from BL editions



Fig. 4.75 3 mm assembled unattributed alphabet from BL editions

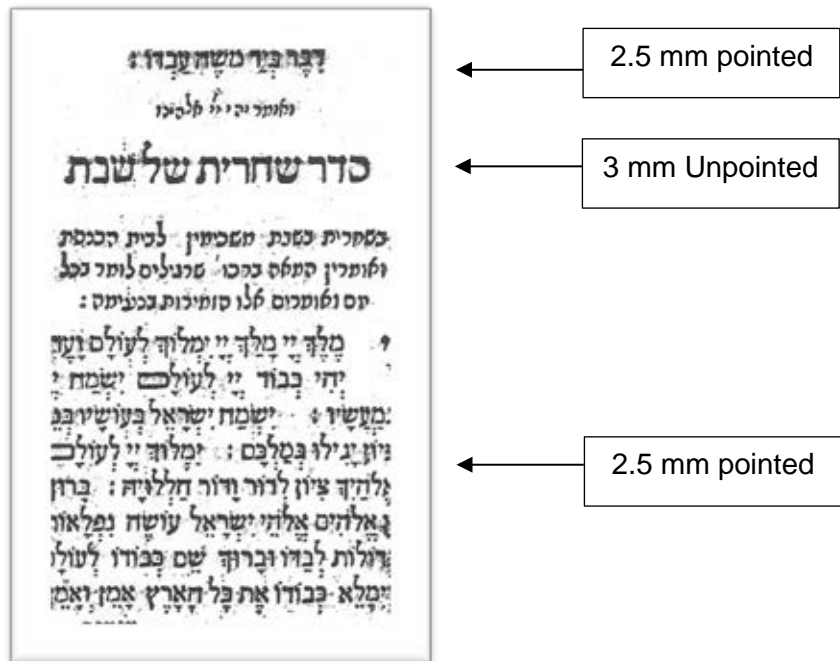

Fig. 4.76: Page from *Seder Tefilot mi-khol ha-Shanah*, Venice, 1545 showing 3 mm unpointed and 2.5 mm m pointed setting Actual size (BL 1973a19)

A similar Hebrew was also seen in the *Sefer menorat haMoar* of R. Isaac Aboab the Elder and in the *Pirkei Rabi Eliezer*, both printed by Giovanni di Farra in 1544. The x-height of this Hebrew is 2.9 mm. It has the same tell-tale angle on the left hand stroke of the ayin, the bulbous upper termination on the lamed; the angled join of the baseline and oblique stroke of the tsadde, and the left facing termination on the middle stroke of the shin.



Fig. 4.77: Specimens of the 2.9 mm Hebrew from the *Menorat HaMaor*, Di Farra, Venice, 1544 Actual Size (BL 1935g8)

Attributions for this typeface in printed editions:

- *Machzor* (Daily Prayers), Venice, 1545
- *Sha'ar bet H. he-hadash: ... Humash im Targum va-Hamesh megilot ve-Haftarot*, Venice, Giustiniani, 1546
- *Seder tefilot mi-kol ha-shanah*, Venice, Giustiniani, 1546
- *Sefer HaShorashim*, Venice, Giustiniani, 1547
- *Sefer Meir Iyov*, Venice, di Cavalli, 1567
- *Sefer Kol-Bo*, Venice, di Cavalli, 1567

- *Sefer Haguda*, Cracow, Prostitz, 1571?
- *Sefer Ne'im Zemirot*, Cracow, Prostitz, 1576?
- *Biblia sacra, Hebraice, Graece, & Latine*; Geneva, Officina Sanctandrea, 1587?
- *Bible/Pentateuch*, Venice, Bragadin, 1590
- *Pithu Sha'arim*, Basle, Waldkirch, 1599

Hb39 (S)

Appears on: Rés-X-1665, folio 13
Size: Great Primer (Gros-Romain)
Type Classification: Square Hebrew Sephardic pointed
Measurements: x-height of 2.5 mm; 20:115 (vocalized)
Date of creation: 1532?
Punchcutter: François Gryphius?
Materials preserved: None
Type Specimens: Le Bé, Rés. X 1665, folio 13, Omont, 1887, 6
Literature: Vervliet, *Conspectus*, 404 (No. 386 Hb 2.5)
First occurrence: Jan van Campen, *Psalmorum omnium iuxta Hebraicam veritatem paraphrastica Interpretatio*, Claude Chevallon, Paris, 1532

Omont first attributed this typeface to Jean Picard, whereas Vervliet in his *Conspectus* has attributed it to the Parisian printer and punchcutter François Gryphius with a first appearance in Jan van Campen's *Psalmorum omnium iuxta Hebraicam veritatem paraphrastica Interpretatio*, printed by Claude Chevallon in Paris in 1532.⁶⁸² Vervliet notes that Gryphius, 'the younger brother of the well-known Lyons printer, Sebastian Gryphius, has hitherto not been recognized as a punchcutter', and bases this conclusion on the fact that Gryphius 'used only typefaces that, as a rule, no other printer had used before him'.⁶⁸³

Le Bé describes Hb39 (S) as 'vielle lettre mal faicte', meaning either crudely cut or justified and attributes it to the *libraire/imprimeur* Martin le Jeune.⁶⁸⁴ This almost certainly does not mean that it was cut by Le Jeune, but was used by him for his various Hebrew editions. It has none of the elegance of Le Bé's typefaces, although it is not a difficult face to read. The similar pairs, such as Chet/heh (ח/ה), bet/kapf (ב/ב) and dalet/resh (ד/ד) are reasonably well differentiated. The extended characters are over heavy and stand out from the surrounding text. There is little doubt from the evidence of the setting of the specimens that the characters with ascenders and descenders were kerned to allow as close a fit as possible with the vowels and cantillation marks. The text in the specimen is from Psalms 119:40-51 and is from Martin Le Jeune's edition of *Torat HaMashiach (Evangelium secundum Matthaeum)* of 1551.

Martin Le Jeune's use of Hb39 (S) may be related to his publication of at least four works by the orientalist Guillaume Postel (*De Universitate Liber*, *De Foenicum Literis* and *Compendaria Grammatices Hebraicae Introductio*, all printed in 1552 and *Les*

⁶⁸² Omont, *Specimens de caractères hébreux gravés à Vénise et à Paris par Guillaume Le Bé, 1546-1574*, p. 6

⁶⁸³ Vervliet, *French Renaissance Printing Types: A Conspectus*, pp. 38-39

⁶⁸⁴ Philippe Renouard, Jeanne Veyrin-Forrer, and Brigitte Moreau, *Répertoire des imprimeurs parisiens, libraires, fondeurs de caractères et correcteurs d'imprimerie depuis l'introduction de l'Imprimerie à Paris (1470) jusqu'à la fin du seizième siècle* (Paris: Lettres modernes, 1965), pp. 261-262

Premiers Eléments d'Euclide chrestien in 1579).⁶⁸⁵ Martin Le Jeune was active as a printer in Paris from 1548 through 1584, and his press was initially situated in the 'rue Saint Jean de Latran, à l'enseigne du Serpent', thus a close neighbour of Guillaume I Le Bé.⁶⁸⁶ Le Jeune also published some 68 editions which use Hebrew type from 1549 to 1584, and this large production would have required a reasonable stock of Hebrew types. Lyse Schwarzfuchs notes that Le Jeune had three Hebrew types which can be attributed to Claude Chevallon/Charlotte Guillard and Robert I Estienne. We may now add the name of François Gryphius to the list.⁶⁸⁷ The Hebrew alphabet from Génébrard, *Hebraicum alphabetum*, Martin le Jeune, Paris, 1564 is a provisional attribution, given the vagaries of ink squash.



Fig. 4.78: Hb39 (S) Assembled alphabet from the Le Bé specimen and the *Evangelium secundum Matthaenum* Actual size (BL 218b12)



Fig. 4.79: Hb39 (S) Assembled alphabet from Le Bé specimen and the *Evangelium secundum Matthaenum* Enlarged 1.5x (BL 218b12)



Fig. 4.80: Hb39 (S) Page from the *Evangelium secundum Matthaenum* Actual size (BL 218b12)

⁶⁸⁵ Postel, *Les Ecrits de Guillaume Postel publiés en France et leurs éditeurs 1538-1579*, pp. 66-68

⁶⁸⁶ Renouard, Veyrin-Forrer, and Moreau, *Répertoire des imprimeurs parisiens, libraires, fondateurs de caractères et correcteurs d'imprimerie*, pp. 261-262

⁶⁸⁷ Schwarzfuchs and Coron, *Le livre hébreu à Paris au XVIe siècle*, pp. 55-56, 251



**HEBRAEORVM LI-
TERAE VIGINTIDVAE,
QVARVM HAEC SVNT,**

<i>Nomina</i>		<i>potestas</i>	<i>figura & ordo.</i>	
אֱלֶפְ	áleph	<i>spiritus tenuis</i>	א	1
בֵּית	beth	b. β	ב	2
גִּמְלֵל	Gimél	g γ	ג	3
דָּלֶת	dáleth	d δ	ד	4
הָא	he	h <i>asper</i>	ה	5
וָו	vau	v	ו	6
זָיִן	záin	z	ז	7
חֵת	hbeth	hh <i>spiritus asper duplex.</i>	ח	8
טֵת	teth	t <i>durum.</i>	ט	9
יֹד	iod	i	י	10
כָּף	caph	c χ	כ	11
לָמֶד	lámed	l	ל	12
מֶם	mem	m	מ	13
נּוּן	nun	n	נ	14
סָמֶךְ	sámech	s <i>vulgare</i>	ס	15
עָיִן	áin	* G <i>frangulum.</i>	ע	16
פָּא	pe	p φ	פ	17
צָדִי	tsaddí	ts	צ	18
קָף	coph	k q α	ק	19
רֵשׁ	resh	r	ר	20
שִׁין	shin	sh	ש	21
תָּו	tau.	t & ϑ	ת	22.

A ii Ll.

Fig. 4.81: Hb39 (S) Page from Gilbert Génébrard, *Hebraicum alphabetum*, Martin le Jeune, Paris, 1564 (Gallica.fr French books before 1601; 489.3)

Attributions for this typeface in printed editions:

- Jan van Campen, *Psalmorum omnium iuxta Hebraicam veritatem paraphrastica Interpretatio*, Paris, Claude Chevallon, 1532
- Johannes Vallensis, *Opus de prosodia Hebraeorum in quatuor libros diuisum*, Paris, Jacques Bogard, 1545
- Jean Cassien, *De incarnatione Domini Libri VII*, Paris, Pierre Gaultier pour Jean Barbé et Claude Garamont, 1545

- Jean Cinquearbres, *De re grammatica Hebraeorum opus*, Paris, Martin le Jeune, 1549
- *Evangelium secundum Matthaeum*, Martin le Jeune, Paris, 1551 (See BL 218b12 *Evangelium Secundum Matthaeum*, f. Aviii)
- Gilbert Génébrard, *Hebraicum alphabetum*, Paris, Martin le Jeune, 1564?
- Jean Cinquearbres, *De notis Hebraeorum liber*, Paris, Martin le Jeune, 1582

Hb40 (S)

Appears on: Rés-X-1665, folio 14 and 20
Size: Petit-texte (Picard's Pica Hebrew B Hb 1.6 or Cicéro)
Type Classification: Square Hebrew Sephardic pointed and unpointed
Measurements: x-height of 1.6 mm; 20:78
Date of creation: c. 1545
Punchcutter: Jean Arnoul dit Picard le jeune
Materials preserved: None
Type Specimens: Le Bé, Rés. X 1665, folio 14 and 20, Omont, 1887, 5
Literature: Vervliet, *Conspectus*, 391 (No. 370 Hb 1.6)
First occurrence: *Sefer HaKuzari*, Venice, Parenzo, 1547

On the specimen for folio 14, there is an annotation which was overlooked by Omont in his first analysis of the documents. It reads: 'ce petit texte est de Jehan Picard a (ou de) Paris decedé a Lyons'. The page is from a 1549 edition of the *Mishnah* printed by Meir di Parenzo for Carlo Querini in Venice, and the actual text is from Chapter 5 of the Pirkei Avot (פרקי אבות). The specimen page is from the Mishnaic tractate of *Avot*, which is usually the final tractate in the order of *Nezikin* in the Talmud. The second specimen appears on Folio 20, and is clearly a printer's specimen, as it includes three lines of vocalised setting, followed by four lines of random words and characters in alphabetic order. Le Bé also attributes this typeface to 'Jehan Arnoul, dit Picard, decedé a Lyon, duquel j'euz la presente frappe que je vendis a Venise a Maz de Parense'.

It seems likely that this typeface was cut by Jean Arnoul dit Picard, either in Paris or in Lyons, who gave the strikes to Le Bé before he left for Venice. Once settled in Venice, Le Bé sold them to Meir Parenzo, who had served as a kind of foreman or perhaps 'prote' to both Bomberg and later Alvise Bragadin, before issuing at least five editions under his own name. Marx commented that Parenzo's types were 'generally very small types, well printed, cleanly and evenly, and always clearly legible'.⁶⁸⁸

This description is indeed well suited to Hb40 (S), which is highly legible, given its small appearing size. The shin is a key recognition character, where the middle stroke joins the baseline at the juncture of the left hand stroke and the baseline at a very sharp angle. There were also extended characters, which can be seen in the specimen below from the 1547 *Sefer HaKuzari*. They do not appear on the specimen on Folio 20, so possibly they were added later.



Fig. 4.82: Hb40 (S) Assembled alphabet (Actual size)

⁶⁸⁸ Jacob Rader Marcus and Marc Saperstein, *The Jew in the Medieval World: A Source Book, 315-1791* (Cincinnati: Hebrew Union College Press, 1999), pp. 461-462. See also Marx, *History and annals of Hebrew printing*, the section on Meir Parenzo. 'im allgemeinen sehr Kleine Typen. Sehr schoen, sauber und gleichmaessig, und immer klar leserlich gedruckt'.

אבגדהווחטיכהלמסננספפצץקרשת:

Fig. 4.83: Hb40 (S) Assembled alphabet (Enlarged 2x)

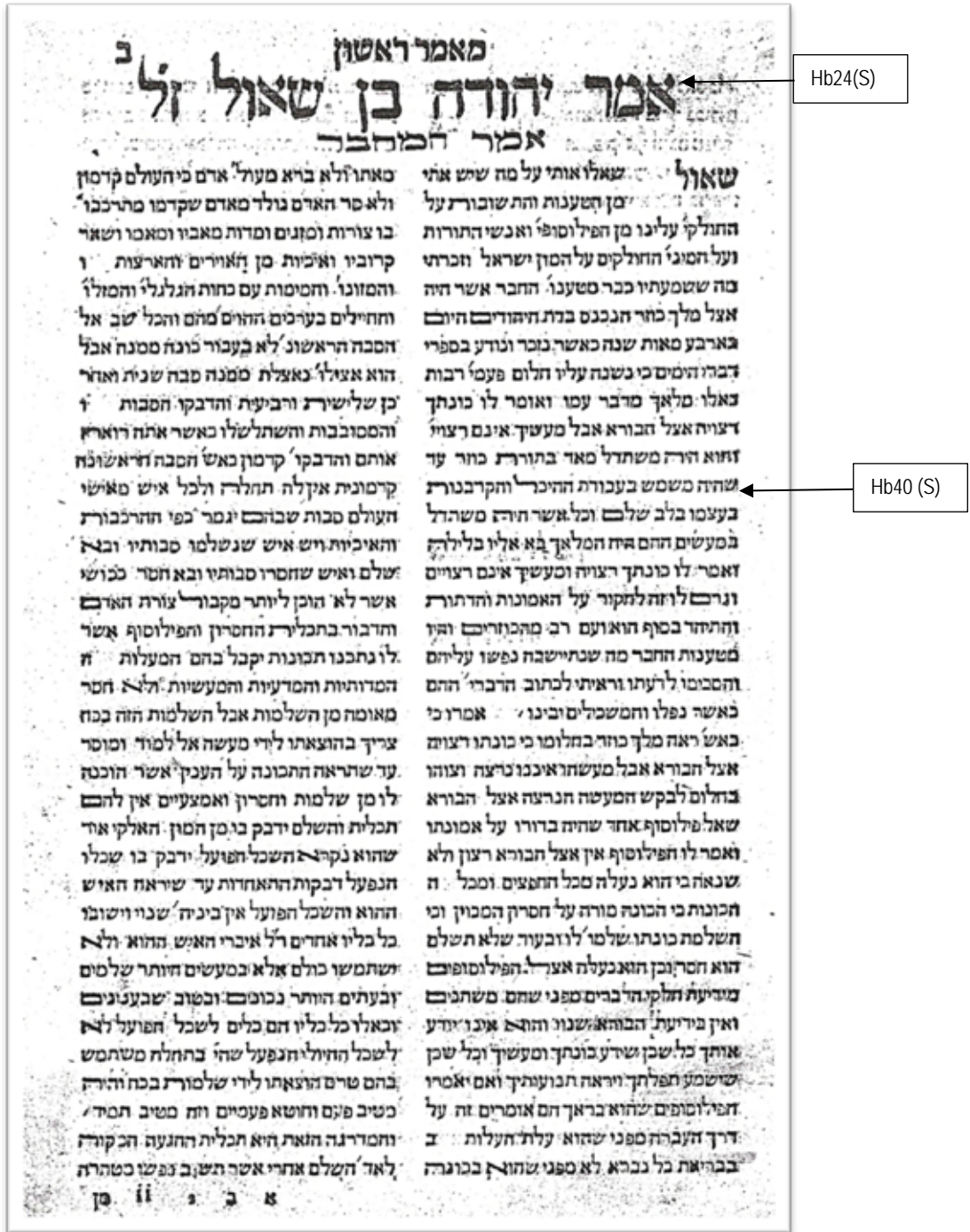

Fig. 4.84: Hb40 (S) used as text face from a page from *Sefer HaKuzari*, Venice, Parenzo, 1547 showing additional extended characters (BL 1932d10)

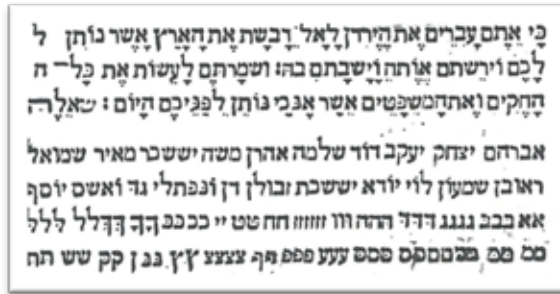

Fig. 4.85: Hb40 (S) from 1665 folio20 (Actual size)

Attributions for this typeface in printed editions:

- *Sefer HaKuzari*, Venice, Parenzo, 1547
- *Sefer Sha'ar HaShamayin*, Venice, Parenzo, 1547
- *Sefer Sha'arei Dura*, Venice, Parenzo, 1547
- *Mishnayot Meseder Mo'ed*, Venice, Parenzo, 1548-49
- *Mishnayot Meseder Kadoshim*, Venice, Parenzo, 1548-49
- *Mishnayot Meseder Nashim*, Venice, Parenzo, 1548-49
- *Sefer Kaftor vePerach*, Venice, Parenzo, 1549?
- *Sefer Arba'ah Turim*, Cremona, Conti, 1558?

Hb41 (S)

Appears on: Rés-X-1665, folio 15

Size: Petit texte?

Type Classification: Square Hebrew Sephardic unpointed

Measurements: x-height of 1.9 mm; 20:89

Date of creation: Unknown

Punchcutter: Unknown

Materials preserved: None

Type Specimens: Le Bé, Rés. X 1665, folio 15

Literature: None

First occurrence: *De Literis Hebraeorum*, Basle, Typis Martini Wagneri, 1643?

This folio is once again clearly a proof of a type specimen, showing 20 lines of unvocalized setting, and including four lines of various sorts set in alphabetic order. The Biblical text in the specimen is from Leviticus 1:1-10. There is no annotation on the specimen to indicate who cut it, nor where it came from. The fifteen handwritten characters below the specimen show a hand well familiar with Hebrew calligraphic letterforms, and could point to suggested corrections to the sorts already cut. The alphabetic lines show a variety of sorts with dagesh points, but no indication of vowels or cantillation marks. There are also extended characters for the aleph and the final mem, and more were available as can be seen from the page from the *Liber Cosri*.

The immediate recognition factors for this fount are the ayin, the tsadde, the final tsadde and the shin. The ayin has a distinctive angle to the left hand stroke, the final tsadde has a sharply angled downstroke to the descender, and the shin shows the three upper terminations all pointing left. These characteristics might link it to the anonymous unknown engraver for the mint (Graveur de Monnaye et cachetz) already identified by Le Bé in Hb38 (S), which could indicate a Venetian origin in the 1540s, but, if so, the unexplained question is why the first unambiguous use found to date is from Basle in the seventeenth century.



Fig. 4.86: Hb41 (S) Assembled alphabet from 1665 folio 15 (Actual Size)



Fig. 4.87: Hb41 (S) Assembled alphabet from 1665 folio 15 (Enlarged 2x)

אל משה וידבר יהוה אליו מאהל מועד לאמר דבר
אל בני ישראל ואמרת אליהם אדם כי יקריב מכם
קרבן ליהוה מן הבמה מן הבקר ומן הצאן תקריב
אבן קרבנכם אם עולה קרבנו מן הבקר וזכר תמים
יקריבנו אל פתח אהל מועד יקריב לתו לרצונו
לפני יהוה וסמך ידו על ראש העולה ונרצה לו לכפ
עליו ושחט את בן הבקר לפני יהוה והקריבו בני
עאהרן הכהנים את הדם וזרקו את הדם על המזבח
סביב אשר פתח אהל מועד והפשיט את העולה
ונתח אתה לנתחיה ונתנו בני אהרן הכהן וש
על המזבח וערכו עצבים על האש וערכו בני אהרן
הכהנים את הנתחים את הראש ואת הפרט על הע
העצבים אשר על האש אשר כל המזבח וקרבו וקרעו
ירחץ במים והקטיר הכהן את הכל המזבח זה פולה
אשר ריח ניתח ליהוה ר ואסמן הצאן קרבנו מן
הכבשים או מן הפזים לסולה זכר תמים אאאא
אאאא אאאא אאאא אאאא אאאא אאאא אאאא אאאא
אאאא אאאא אאאא אאאא אאאא אאאא אאאא אאאא
אאאא אאאא אאאא אאאא אאאא אאאא אאאא אאאא
אאאא אאאא אאאא אאאא אאאא אאאא אאאא אאאא
אאאא אאאא אאאא אאאא אאאא אאאא אאאא אאאא

Fig. 4.88: Hb41 (S) Specimen from 1665 folio 15 (Actual Size)

P R A E F A T I O

מכתב רב הסראי בן יצחק מכ למלך אלכור :

אפודת גור לשבט מושלים הממלכה הנחלארה . נועם ה עליה . ושלום בכל
מחוקקיה ורב צבאה . ישע תלבושת על מלוכה ומועדה ומקראיה : חילי צמאה
ושלטי הגבורים יעונו ביד המפלארה : שומי מרכותיה ורוכביה כל יסוגו אחור ברוח
נכאה : דגלי מפסדיה ודרוכי לחמיה יעטו גאה גאה : את חיצו רכיה וברק
חניתיה בכבוד משאה : יפלחו לב אויבי אדני המלך למען רבות תלארה : בצאוני
מרבבותי ילין עוז ורגש ויראה : רוכביה ישעון ובשלוה ישובו מארץ נוראה :
יחידתי לזאת תשתפך אשרי עין שרואה : צאת המלך ביום קרב בחמה זרוחה ופליאה :
חיליו כברקים ירצון שנים לרבה זאחד למאה : קמיהם יעיקון כאשר תעיק העגלה
המלארה : בינו נא מצוקי ארץ ומי שמע כזאת ומי ראיה : רדות שריד באמרים
ינסו ויסתירו עיר ומלוארה : עוז זרוע עלין אלים גם עורם ותהי לתשווארה : זאת
פעלת שדי ומנת גמולו בממלכה החטאה : רבות את הוד ותפארת ניר לאום מני
בטן נשווארה : אוכרה אותות מני קדם ורוב עברה ורעל אגמאה : בהיותה דבוצה
על עדניה ועל שמריה קפוארה : רק רגולה היתה וזנה זרויה לכל רוח זפארה : שמש
שזפה ותלך עליה ומנוח לא מצארה : פדה לא נפדתה ואת עת הדורור לא בארה :
רצוצה ברצועת און ואל חופש לא יצארה : ונותרה בעניה ושבורה ומשכר לא
סבוארה : טורפיה השגוה וממקדש הקדש הוציאוה : ארכו העתים ונמשכו הימים
ומופת לא נראה : נחתם חזון ונביא ולא נפרץ רוח ולא מראה : חזוניה איש
חמודורה לא יגלו ולא נותר כל נבוארה : אל אל אילותי אפרש כפי כנפס צמאה :
פזורי קצות פזורי אפסידים לאסוף מארץ משוארה : גוני המועד או לאל יבעו העת
שקוינהו והניה בארה : נצח קרית מלך רב תקיאים כאשר קארה : רוממות מעת
תראינה עיני שארית הנמצאה : וממלכת בן ישי בסוד חזות הנבוארה : קרנך אישם
ברזל לנצח מהיום ההוא והלאה :

Fig. 4.89: Portion of Page from Johann Buxtorf, *Liber Cosri, Continens colloquim seu disputationem de religione*, Georg Decker, Basle, 1660. Actual Size (John Rylands University Library, Manchester. Teltscher J193)

Attributions for this typeface in printed editions:

- *De Literis Hebraeorum*, Basle, Typis Martini Wagneri, 1643
- Buxtorf, *Liber Cosri*, Basle, Georg Decker, 1660

Hb42 (S)

Appears on: Rés-X-1665, folio 15
Size: Petit texte?
Type Classification: Square Hebrew Sephardic unpointed
Measurements: x-height of 2.1 mm; 5:19
Date of creation: Unknown
Punchcutter: Unknown
Materials preserved: None
Type Specimens: Le Bé, Rés. X 1665, folio 15
Literature: None
First occurrence: Unknown

This specimen is found on the same folio as Hb41 (S) and has no annotation to indicate either punchcutter or origin. It is slightly larger in appearing size than Hb41 (S) and has several characters with similar characteristics: the shin with the termination flag on the middle stroke pointing left, the final tsadde with a pronounced right angle to ascender, the tsadde with a 45 degree angle to the juncture of the oblique stroke and baseline. It is a darker typeface, with less differentiation between the thin and thick strokes, but the fact that Le Bé placed it on the same folio as Hb41 (S) may indicate a common origin. It was not found in any of the editions examined for this thesis.

The actual text is a puzzle, as it appears to be a mélange of correct and nonsense Hebrew. It was not located in any Biblical text or commentary following a comprehensive search of the Bar Ilan online Responsa Project.⁶⁸⁹ The incorrect use of final characters is evidence that it was made as a proof of the typeface to demonstrate the range of characters that had been cut.



Fig. 4.90: Hb42 (S) Assembled alphabet from Le Bé specimen (Actual size)



Fig. 4.91: Hb42 (S) Assembled alphabet from Le Bé specimen (Enlarged 2x)

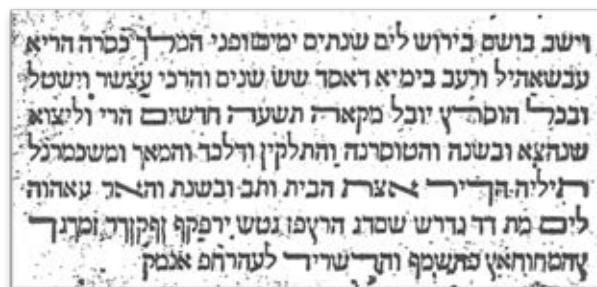

Fig. 4.92: Hb42 (S) Le Bé specimen from 1665 folio 15 (Actual size)

⁶⁸⁹ 'Online Responsa Project' (<<http://www.responsa.co.il/default.aspx>> [Accessed 6 November 2013])

Hb43 (R)

Appears on: Rés-X-1665, folio 19v

Size: Glose Hebraïque

Type Classification: Rashi Script unpointed

Measurements: x-height of 1.9 mm; 5:19

Date of creation: Unknown

Punchcutter: for Cornelio Adelkind?

Materials preserved: None

Type Specimens: Le Bé, Rés. X 1665, folio 19v

Literature: Omont, 1887, p. 6

First occurrence: Unknown

Le Bé describes this fount on his annotation as a ‘glose hébraïque de messer Cornelio, chrestien baptise, correcteur en l’imprimerie des Bombergues, bien antique et taillée d’un bon maistre’. The ‘messer Cornelio’ is without any doubt Cornelio Adel Kind, who was the foreman of Bomberg’s press as well as being his corrector. Amram writes that ‘the Bomberg press since its establishment had employed the family of Adelkind, father, sons and grandsons, another family who under different circumstances might have established a famous press like that of the Soncinati. Most prominent among the clan of the Adelkinds was Cornelio the friend and associate rather than the subordinate of the master, in whose press room he served for upwards of three decades. So great was his merit as a printer that Bomberg permitted their names to be associated on the title page of many books and in some even allowed Cornelio’s to appear alone’.⁶⁹⁰ Adelkind worked for at least three Venetian printers during and following his association with Bomberg: Giovanni dei Farri in 1544, Marco Antonio Giustiniani from 1545 to 1552, and finally for Tobiah Foa in Sabbioneta from 1553 to 1554.⁶⁹¹

Le Bé’s comment about Cornelio Adelkind’s conversion to Christianity – or apostasy as viewed from the Jewish perspective, seems to be confirmed by Adelkind’s epitaph to the 1546 Bomberg edition of Eliahu Levita’s *Dikdukim*, in which he writes that ‘Israel was my name and as Cornelio I will be remembered’. This was not unusual at the time nor for the Bomberg press, as he had used the services of three Jews who had converted to Christianity: Felice da Prato (Felix Pratensis), Jacob ben Hayyim and Isaiah Parnas.⁶⁹²

The fact that Le Bé attributes this typeface to Adelkind does not mean that it was cut by him. It is worth noting Le Bé’s phrase ‘bien antique et taillée d’un bon maistre’, which implies that it was cut by a skilled punchcutter. It is also different from the other Rashi Scripts used in the Bomberg oeuvre and is not listed in the analysis of the

⁶⁹⁰ Amram, *The makers of Hebrew books in Italy*, pp. 180-183

⁶⁹¹ Avraham Meir Habermann, *HaMadpis Cornelio Adel Kind u-Beno Daniel (In Hebrew)* (Jerusalem: Rubin Mass, 1980) in English summary

⁶⁹² Amram, *The makers of Hebrew books in Italy*, pp. 186, 189

Bomberg types compiled by Kalman.⁶⁹³ The typeface is more calligraphic in its character and also has more differentiation between the thick and thin strokes. The distinctive features are the bet with an extended and angled baseline, the final nun, the gimmel with the lengthened vertical stroke meeting the baseline at a 90 degree angle, and the 'hook' on the final tsadde. It also has a smaller version of the kapf which can be seen on line one of the specimen below, which is similar to the kapf used by Le Bé in Hb18 (R). The text of the specimen is most likely from an as yet unidentified edition of Rashi's *Siddur*, Chapter 502? (תקב). This fount was not found in any the specimens examined for this thesis.



Fig. 4.93: Hb43 (R) Assembled alphabet from Le Bé specimen (Actual size)



Fig. 4.94: Hb43 (R) Assembled alphabet from Le Bé specimen (Enlarged 2x)

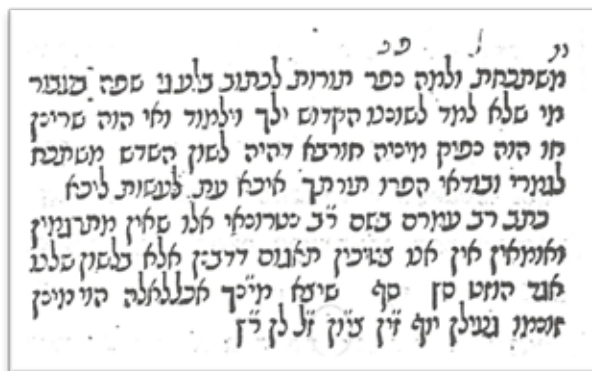

Fig. 4.95: Hb43 (R) Le Bé specimen from 1665 folio 19v (Actual size)

⁶⁹³ Kalman, 'The Bookcraft of Daniel Bomberg's Press', pp. 94-100

Hb44 (R)

Appears on: Rés-X-1665, folio 19 and 19v
Size: Glose
Type Classification: Rashi Script unpointed
Measurements: x-height of 2 mm; 20:90
Date of creation: Unknown
Punchcutter: From Constantinople
Materials preserved: None
Type Specimens: Le Bé, Rés. X 1665, folios 19 and 19v
Literature: Omont, 1887, p. 7
First occurrence: *Mishnayot*, Soncino, Naples, 1492?

The two specimens for this typeface on folios 19v are taken from the edition of *Sha'arei HaTeshuva*, printed by Gershom Soncino in Fano in 1505/6. The text is from the *Sefer Sha'arei Teshuva* (the Gates of Repentance), by the thirteenth-century Catalan rabbi and moralist Yonah ben Abraham Gerondi.

An earlier appearance for this same Rashi is to be found in an edition of the *Arba'ah Turim*, printed in December 1493 at the press of David and Samuel Ibn Nachmias in Constantinople. Adri Offenberg has analysed this edition and its history, the first 'book printed in the Near East, and also the first product of the printing press in South-East Europe'. Offenberg is quite certain that 'the type with which are printed the titles in its various parts, chapters and paragraphs, as well as the decorative initial at the beginning of the text, are undoubtedly of Spanish origin'. He is also quite certain that the 'ordinary typeface in which the *Arba'ah Turim* is printed, formerly referred to as "rabbinical" or "Rashi letter", but nowadays more prosaically called semi-cursive, obviously comes from Naples'. This type is Hb44 (S), the specimen in the Le Bé document 1665, folios 19 and 19v.⁶⁹⁴ Offenberg also adds that this Rashi Script/semi-cursive type is 'identical with the text type of Joshua Soncino, last used by him in his grandiose *Mishnah* edition of 8 May 1492'.⁶⁹⁵ He makes the very logical assumption that the Nachmias Brothers had connections with the Soncino family, and this would explain the fact they had the Soncino Rashi types 'at their disposal'.

It is not known who cut the punches for this type. Le Bé does not say and only notes that the specimen came from Constantinople. Offenberg writes that 'twelve years later they (i.e. the Nachmias Brothers) were using apparently the same type on a smaller body, making it probable that at the same time they had the use of the matrices and possessed their own typefoundry'. He also notes that the edition of the *Arba'ah Turim* shows extended letters (*Litterae dilatabiles*), which 'are not found in

⁶⁹⁴ A. K. Offenberg, 'The printing history of the Constantinople Hebrew Incunable of 1493: A Mediterranean voyage of Discovery', *British Library Journal*, 22 (1996), pp. 223-224

⁶⁹⁵ According to Amram's list of the Soncino editions, this would be the *Mishnah* with Maimonides, printed in Naples. See Amram, *The makers of Hebrew books in Italy*, p. 140

the Soncino editions'.⁶⁹⁶ The Le Bé specimen and the edition in which it is found do not have any extended letters, but it does have the aleph/lamed ligature. A possible specimen seen in the c. 1515 Constantinople edition of *Mishpatei HaCherem, veHanidui, ve Hanezipha*, which does contain examples of *litterae dilatabiles*.⁶⁹⁷

Are there any clues in the writings on or about Gershom Soncino as to the origin of this typeface? Soncino left a lengthy biographical note on the title page of his edition of Kimchi's *Michol*, printed in Constantinople in 1533. He writes of his work of 'editing texts' and of his travels to France and Switzerland to seek out 'books which have ... been concealed dark and obscure'. He does not mention specifically any details of his presses, his type or the paper used. Moses Marx maintains that Soncino 'assumed all the editorial tasks ...read proofs, and certainly, at all times had his eyes upon the whole of the business as well as his hands in everything'. Soncino, unlike his rival Daniel Bomberg, hardly mentioned the names of his editors, assistants or associates during 'the whole period of his activity as a printer of Hebrew from 1485 to 1534'.⁶⁹⁸ It is possible that he had a hand in cutting his own types. Marx cites the Renaissance writer and humanist Alessandro Gaboardo da Torricella, who remarked that Soncino 'has a good name as a printer, that he prints with particularly beautiful types, and that his books are marked by their outward elegance'.⁶⁹⁹

This Soncino Rashi is indeed a highly legible typeface, with a strong horizontal emphasis. The down strokes are lighter than the base and upper strokes. There is also attention given to the 'side bearings' of the characters so the individual characters are clearly differentiated. Note the final nun with the left facing termination flag, and the angled vertical stroke of the gimmel. The final peh is not seen in the Le Bé specimen, but has the distinctive 'bishop's crook' shape to it.

The inclusion of this Incunabula typeface in the specimen is further evidence of Le Bé's knowledge of the historical varieties of Hebrew printed letterforms. He could have acquired such specimens during his period in Venice,



Fig. 4.96: Hb44 (R) Assembled alphabet from Le Bé specimen 1665 folios 19 and 19v (Actual size)



Fig. 4.97: Hb44 (R) Assembled alphabet from Le Bé specimen 1665 folios 19 and 19v (Enlarged 2x)

⁶⁹⁶ Offenberg, 'The printing history of the Constantinople Hebrew Incunable of 1493', pp. 26-227

⁶⁹⁷ Kestenbaum & Company, 'Fine Judaica: Printed Books, Manuscripts, Autograph Letters, Graphic & Ceremonial Art To Be Auctioned On Thursday, January 31st', p. 56

⁶⁹⁸ Moses Marx, 'Gershom (Hieronymus) Soncino's Wander-Years in Italy, 1498-1527 Exemplar Judaicae Vitae', *Hebrew Union College Annual*, XI (1936), pp. 484-498

⁶⁹⁹ *Ibid.*, p. 496

מן העולם הזה כי הרשעים יעשנו כצור וייסורין או במותי וכן יעשנו במשפט על מעשי
 בעולם הבא לקץ ומן אכל אויבי השם המשיח לחלבי הקטנים ושמונים שאור נתן
 נכלה בעשן ולא המשיח לבשר הכרים כי יעשה גחלת וישאה האפר על כן אפר
 בעשן כלו כאשר חלבי הכרים כלים בעשן כן יכלו אויבי השם כי תכלה נפשם ותא
 מן העולם הבא וז' פוקד עין אבות על בנים על שלמים ועל רשעים וענין שונאי
 במצא לפעמים גם באנשים שהם עשוי המצות ומוקרים מכל עבירה במעשה וכלאן
 בפשם רעה ובקרב לבם יקצה להם כאשר חביריהם עושים בתור' וירע בעיניהם לה
 בני אדם עובדי את השם ויריאים מלפניו כאשר תאמר על האים אשר לא יתפון זיב
 בני אדם את המלך וז' עבדו כי הוא שונא את המלך כש'אם הציאו מחשבתם הרעם
 הפעל זה מניאים את לב בני אדם מעסק התורה ומן המצות כי הם שונאי השם
 האנשים אשר עינם צרה בכבוד תלמידי חכמים ישרים והדיוקים ושונאים עט
 תפארתם או ירע לבדם אם עדיהם תאתה ובבאה ממאלת הדור' וכן כתוב כי לא
 מאסו בי אם אותי מאסו ממלך עליהם וכל שכן אם יבקשו כבודם לכלמה או יא
 וכן אם יאהבון בבדור הרשעים ומשלים יבל עפר כי אלה באמת שונאי השם ואין
 בקיום עבודתו ולא יחפז בהדרת קדש יראתו ואשר ירבון מאד עבדיו ויריאי וכן
 המחבלים כרם השם כמו המונסרות ומחטיאי הרבים הנה הם שונאי השם כאשר ת
 כי האנשים המאחיתים ערי המלך או כרמינו ופרדסיו כי הם שונאי המלך וכן כ
 צבאות בית ישראל ובית יהודה נטע שעשועיו וז' על עמך יערימוהו וז' כי נוע
 יחדיו עליך ברית יכרותו וז' ורזונים נשדו יחד על ה' ועל מציחו על כן אצל כי המה
 נשחטאו וקחטיאו את הרבים יורדין לביהם ונדוכין שם לדורי דורות וכת' קנותי ח

Fig. 4.98: Hb44 (R) Specimen of 20 lines from Le Bé specimen 1665 folio 19 (Actual size)

שהיא בעצמה צותה לעבוד אותה או מי שיאמר שהקבה צוה לי בבדור
 יסוד דבר אלהם וכש'אמר שובחיה אחת מושגי העדות האלה וז' עידן
 עליו עדים כפי שג' בתורה דינו שיהרב בחנק כמו שאמר הקבה וז' כפי
 ההוא או חולם החלום ההוא יומת ואין לנו להביט להתחשן לב וזה
 ולא נבקש מומנו אות' וז' יעשה מן האותיות והמופתים לקח ס' ל
 הנבואה מה שלא שמוענו מושלמים מהם יחנק ואין להביט לאור גתיו
 ש'ועתה קינ' האותיות ההם הוא שאמר הסת' כי מנסה ה' לריכס' תבס
 וז' השכל המוכיב ערניהו יות כאמן מעד העין שהוא רואה או תותו
 שסבר כתבאר במופת' אבל בעלי השכל שאין לסבר ולעבוד זו ה' ה
 האחד המומיאל כל הנמנאים וקתאחים במכלל השלמות:
 והמתכבא בשם יחלקבם כן לשני חלקים
 שיתכבא בשם האל ויקרא ההמונ להחמיין
החלק הראשון
 בו ויצוה על עבודתו ויאמר שהקבה הוסיף
 במצות מנוה או ברע מנוה מכלל המצות שאסף חנות שש' התורה
 ואין הש' בין שיהיה ויגרע על השפוק וכן שיהיה ויגרע על השר'
 המקובל ועב'ן שיהיה או יגרע מן הסתוב כבון שיאמר שהקבה אמר
 אלי כי הערלה היא שתי שנים ואחר שתי שנים מותר לאכל הפירות
 הכטועות או שיאמר הקבה אמ' לי שהערלה אשר לאכל אותה ד שנים
 חלק מה שאמר הקבה שלש שנים יהיה לכה ערלי וכדומה לו או יענה
 בקבלה כג' ואש' יסייענו פשט הכת' כבון שיאמר שזה האומר בתורה

Final Peh

Fig. 4.99: Hb44 (R) Specimen of 20 lines from the 1492 Soncino *Mishniot* From the Hebrew University Digitized Book Repository, F. 1v (Actual size)

Attributions for this typeface in printed editions:

- *Mishniot*, Naples, Soncino, 1492
- *Arba'ah Turim*, Constantinople, 1494
- *Hamishah Humshei Tora*, Constantinople, Nachmias, 1505
- *Sha'arei Ha Teshuva*, Fano, Gershon Soncino, 1506
- *Mishpatei HaCherem, veHanidui, ve Hanezipha*, Constantinople, c. 1515?
- *Teshuvot*, Venice, Bomberg, 1519
- *Teshuvot HaRav*, Constantinople, Soncino, 1547
- *Pentateuch*, Venice, Bragadin and di Gara, 1597

Hb45 (S)

Appears on: Rés-X-1665, folio 19v
Type Classification: Square Hebrew Sephardic unpointed
Measurements: x-height of 3.5 mm
Materials preserved: None
Type Specimens: Le Bé, Rés. X 1665, folio 19v
First occurrence: *Sha'ari Teshevot*, Soncino, Fano 1506?

This typeface appears as cross headings in an edition of *Sha'arei HaTeshuva*, printed by Gershom Soncino in Fano in 1505/6. The text is from the *Sefer Sha'arei Teshuva* (the Gates of Repentance), by the thirteenth century Catalan rabbi and moralist Yonah ben Abraham Gerondi in which this typeface is used as cross headings.

Le Bé attributes the gloss in this specimen to a Constantinople source and it was found in four Constantinople imprints dating from 1494 to 1547.⁷⁰⁰ The square Sephardic on the specimen was not found in any other of the Soncino imprints from the Fano period that were available for examination.⁷⁰¹ There is also a pointed Square Sephardic which was used by the Soncino press for the text of the Hebrew Bible printed in Pesaro during the years 1511 to 1517. The similarities between certain key characters in both founts, such as the gimmel, shin, the lamed, the ayin, and the tsadde are close enough to demonstrate that they are most probably the same typeface, with the addition of extended characters and vowel points at a later date.⁷⁰² Another interesting feature of this typeface is the close 'fit', which is especially apparent in the Soncino Bible with vowels and cantillation marks. This setting also uses a combination of extended characters and the repetition of the initial character from the following line to achieve justification of the lines, a characteristic of earlier Hebrew scribal practice.⁷⁰³

The differences in the forms of the vowel points and cantillation on this edition raise the question whether they were inserted by hand. If this hypothesis is confirmed, this would explain their unusually close fit to the main characters and the differences between different versions of the same sign. The colophon makes no mention of this point and only says that 'I have seen the completion of the printing of the Four and Twenty (Bible) with vowels, accents and corrected.' There is no indication that the Soncino Press ever used such a technique, in addition to the fact that it would have

⁷⁰⁰ The edition was examined in a digitised format at <http://www.hebrewbooks.org/45260> and the volume is held in the Chaim Elozor Reich Renaissance Hebraica Collection. See also page 312 in this thesis.

⁷⁰¹ Amran lists seven imprints for Soncino from 1503 to 1506 from Fano. See Amram, *The makers of Hebrew books in Italy*, p. 141

⁷⁰² Edition examined from the JNUL Digitized Book Repository. http://aleph.nli.org.il:80/F/?func=direct&doc_number=001295061&local_base=NNLALL There is also an copy at the BL 1901.d.10

⁷⁰³ Malachi Beit-Arié, *Hebrew Codicology: tentative typology of technical practices employed in Hebrew dated manuscripts* (Jerusalem: The Israel Academy of Sciences and Humanities, 1981), pp. 88-89

been an extremely consuming process and would have limited the print run. An examination of other Soncino imprints, for example the 1518 edition printed in Ortona of Galatino's *On the Mystery of Catholic Truth* shows the use of a similar pointed Hebrew on the title page.⁷⁰⁴ There is enough differentiation in the placement and treatment of some of the vowel points (e.g. the kamatz and the Patach) to raise the question of how they were inserted or indeed whether they were type set at all.⁷⁰⁵



Fig. 4.100: Hb45 (S) Partially assembled alphabet from *Sha'ari Teshevot*, Soncino, Fano 1506 (enlarged 2x)



Fig. 4.101: Hb45 (S) Partial assembled alphabet from *Arba'ah ve esrim*, Soncino, Pessaro 1511-17 (enlarged 2x)



Fig. 4.102: Hb45 (S) Partial assembled alphabet from *Sha'ari Teshevot*, Soncino, Fano 1506 (Actual size)



Fig. 4.103: Hb45 (S) Specimens from Rés X 1665 f. 19v (Actual size)

⁷⁰⁴ I am grateful to Scott-Martin Kosofsky for this suggestion. See Heller, *The sixteenth century Hebrew book*, p. 41 (Vol I) and Marx, 'Gershom (Hieronymus) Soncino's Wander-Years in Italy',

⁷⁰⁵ *Opus toti christian[a]e reipublic[a]e maxime utile de arcanis catholic[a]e ueritatis contra obstinatissimam Iudeoru[m] ... p[er]fidiam / [auctore, P. Columna]. See also Amram, *The makers of Hebrew books in Italy*, pp. 124-126*

Actual Specimen

חלק החמישי
 המתלונן בדבר ספתים על המעשים וסדורים לא
 סיכונו להם כלבו אך מדרך שמוחים ללא דבר ולא
 וחוק שהחוקים צמיים טגורם לזו מתה סיון וסכרות אל לך סיון אומם אכר כל אגק בו
 לא יחכס פירש לך איז סיון אומם איז אכר כל אגק בו לא יחכס כמו ואזי תפלק איז
 תפלה ורננה כי מתה סיון גורם לטלה דברים רעים אחר לקיות האיז מתלונן וסני
 לקיות אומה ובעל דברים ואמר זל כל המרבה דברים מביא לידי חטאי וזקול כסיל
 ברב דברים וסליסי כל אגק בו לא יחכס ודע כי לא יסיה מנאב סליצמת קבוע כנסם
 האדם עד סקא פרק על סמים מעליו על כן יעבש לתת עליו על היסורין מרס כנגד
 מרס אבעתה אל תתלונן סן יחוקו ממסריכס ואמר זל אמר רבי אלעזר כל המתלונן
 ייסורין באין עליו אבא' סן יחוקו ממסריכס ואמכמים סיו מוסרים לתלמידיקס סלא
 לתלונן גם על דרך מקרס ועראי ועל סחלק סום סנרכו להסור כי רבים יכאלו בו
 על דרך מקרס "

וזס דכר כת סקלים עבין סכת סזו סחלק לתפעס חלקים

חלק האחד
 איז כזכ אכר תורה עוכ וירע ויסחית כמעגס סיו כמ
 סמכס בעמיתו כסקרן או כסאמת יד או כסכר סכיר
 סל לא תכסו ולא תסקרו איז בעמיתו וכן סענה ברעסו עד סקר וזל לא תענה ברעך
 עד סקר ומן סחלק סום בכלל סתרמית וסלונכאות כמסחרים וכסותפנות וזל לא תננו אים
 את עמיתו וזל לא ימים מרסכס תוך ומרמס ונקרא איז און ונקרא כליעל והוא ככד שן
 ככתות סרסעי כאשר סקדמס כסערי יראת חטא ומרז' זס איז סאון סקנא קורן בעיניו
 מולל באככשיתו כמז' אכרס כליעל איז און ונג קורן בעיניו נגמר "

חלק השני
 סמסקר ואין כעס ססקר כוק וספסד לחכרו אך יתכן כו
 לעשות סכס סכוקול סרע כמ סמתעס את סכרו יסאמין
 כו כי קוא אהכ ורע נאמן עמו ומתכוין כזס כדי יכטס כו ולא יסמר ממנו ויזכל לקדיח
 עליו רעס כצין אכסיו אלום את רעסו ידכר וכקרב יזיס ארכר וזל אחריו סעל אלק
 אכאפק נאס ס' אים כגוי אשר כזס לא תתקס כסאי ואלס אזי סחלקים עבסס על סני
 דכרים על ססקר ועל סכוק סכרר ככסיו כי ססקר מלכד כר סכוק קוא סעבת ס' סנא'
 סס סכס אכ' ס' לב חורס מחסכות און עינים רמת לסון סקרי וז' וסי תפסכות סכאתי
 ונאמ' אף כי נתעב ונאלס איז סותס כמים עולה ואף כסר ודס כתעב ססקר להס סנאמר
 תועבת מלכיס אפתי סקר "

חלק השלישי
 סכא בערמה ודכרי מרמס לממע טוכ בעליו להעביר
 סאכס אליו לא לבזול מחכרו דכר סהוא אלו ולא לחמסו
 אכל יתן עימו כעכס סעתידיה לכא לידי סכרו ונודה אותה לקחתה אליו כסקר מלית און
 יסככ כסקרית לו אשר יתן סכרו מתת ועקר עבשו על ססקר אכן יגדל עונס ססקר כאשר

Hb45 (S)

Hb44 (R)

Hb45 (S)

Hb45 (S)

Hb45 (S)

Fig. 4.104: Hb45 (S) Full page *Sha'ari Teshevet*, Soncino, Fano 1506 (Actual size) showing the actual specimen from Rés-X-1665, folio 19v



Fig. 4.105: Hb45 (S) as used in the *Tanach/Bible*, Soncino, Pesaro 1511 -1517 (Reduced 70 per cent). The opening verses of Genesis. Reproduction from JNUL Digitized Book Repository

Hb46 (S)

Appears on: Rés-X-1665, folio 20

Size: Coronelle Hebreu or Grosse Nompaille

Type Classification: Square Hebrew Sephardic unpointed

Measurements: x-height of 1.1 mm; 5:19

Date of creation: Unknown

Punchcutter: Unknown

Materials preserved: MPM ST 55 and MA83a

Type Specimens: Le Bé, Rés. X 1665, folio 20; Omont, 1887, p. 8; See Plantin Folio Specimen c. 1585 Hebreu sur la Coronelle (No. 77)

Literature: None, but see Vervliet/Carter, Type Specimens II, p. 77, Inventaris van de stempels en matrijzen van het Museum Plantin-Moretus, 1960, p. 118

First occurrence: O.T. (*Hamishah Humshe Torah*. 1573-74). Plantin, Antwerp

This is yet another specimen that was sent by Christophe Plantin to Le Bé, with the request ‘pour luy en fayre un plus petit’.⁷⁰⁶ Le Bé records that he had not seen anything similar ‘a Venise, ny Rome, by autrepert’. The specimen is a pointed text from a printed edition, and luckily the specimen in 1665 f. 20 is pasted on one side only, so the reverse side is visible. This shows a signature mark *iii 2*, which indicates that this was the verso page. This type of signature seems to have been found mainly in Italian Hebrew editions, but this particular edition has yet to be found, and neither were any occurrences of Hb46 (S) found in any of the editions examined for this thesis, which may confirm Le Bé’s comment in the annotation.

The best assumption is that this specimen comes from what is called an *enchiridii forma*. The word *enchiridion* comes from the Greek for handbook or manual, and it was a format used by Robert Estienne in his various catalogues.⁷⁰⁷ This particular edition would most likely have been a small pocket-sized prayer book – 16mo or 32mo – given the lack of cantillation marks. The actual text is from Psalms 34:19-23, followed by Psalms 90-91:1. This is the introductory liturgy for Sabbaths and festivals, where Psalm 90 follows Psalm 34, and thus ‘it could come from either a weekly siddur (including Sabbath and holiday prayers) or a holiday Machzor’.⁷⁰⁸

This request from Plantin to Le Bé resulted in the punches (ST55) and matrices (MA83a), now in the MPM. They are labelled as ‘Grosse Nompaille petit Hebreu de G. le be’ or ‘Hebreu sur la Coronelle’.⁷⁰⁹ These punches contain examples of an extended aleph, heh, mem and tav, which Le Bé included in Hb 15 (S).⁷¹⁰ A similar size Square Sephardic Hebrew was used in two Hanau editions printed in 1610 by Hans Jakub Henne. They are not pointed and there are differences in some of the characters, which may be due to ink squash. The punchcutter of this typeface is not

⁷⁰⁶ The first instance is HB17 (S) on page 209.

⁷⁰⁷ Fredric J. Mosher, 'A New Estienne Catalogue', *Library*, s6-I (4) (1979), pp. 365-366. I am grateful to Lyse Schwarzfuchs for her clarification on this point.

⁷⁰⁸ This information is from Dr. Jay Rovner, Manuscript Bibliographer at the Library of the Jewish Theological Seminary in New York. I am most grateful to him for supplying these details.

⁷⁰⁹ Parker, Melis, and Vervliet, *Typographica Plantiniana II*, pp. 38, 98

⁷¹⁰ See page 214 of this thesis.

known, but what it does show is that the need for smaller sized Hebrews remained a desideratum.



Fig. 4.106: Page from *Hamishah Humshe Torah*, Hans Jacob Henne, Hanau, 1610. Actual Size (BL 3408bbb1)

The typeface itself has three characteristics which may link it to the unknown punchcutter of Hb41 (S): the sharp angle of the juncture of the baseline and oblique stroke for the tsadde, the left pointing termination flag of the middle stroke of the shin, and the sharp angle in the ascender of the final nun. But otherwise it is lacking in the elegance of line which are typical of Le Bé's typefaces.



Fig. 4.107: Hb46 (S) Assembled alphabet from Le Bé specimens (Actual size)



Fig. 4.108: Hb46 (S) Assembled alphabet from Le Bé specimens (Enlarged 2x)



Fig. 4.109: Hb46 (S) Specimen from 1665 f. 20 Front side (Actual size)



Fig. 4.110: Hb46 (S) Specimen from 1665 f. 20 Rear side (Actual size)

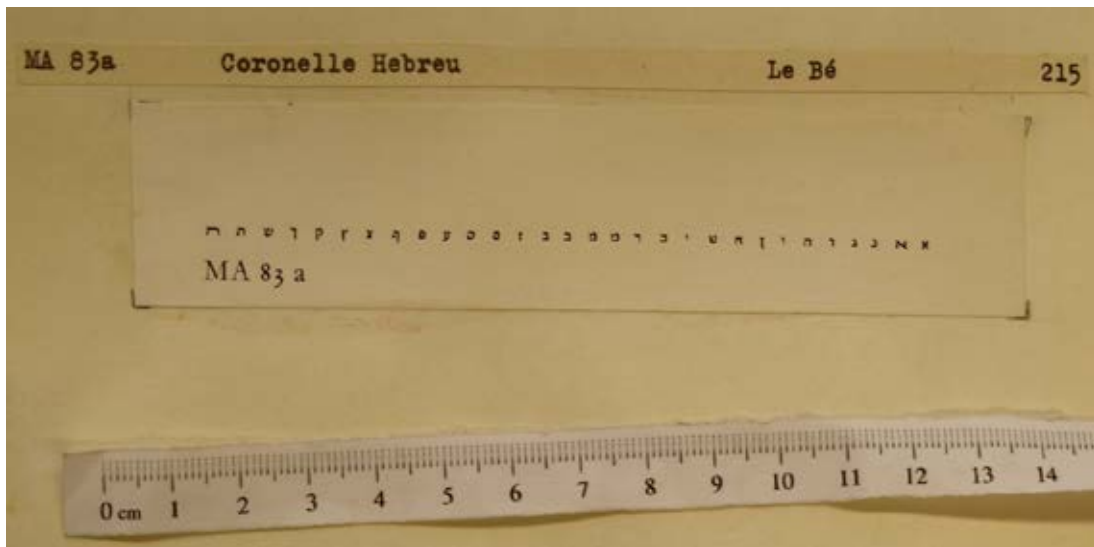

Fig. 4.111: Le Bé's Typeface (HB 15 (S)) which was the result of this request.

Hb47 (R)

Appears on: Rés-X-1665, folio 20v
Size: Moyenne Glose
Type Classification: Rashi Script unpointed
Measurements: x-height of 1.6 mm; 10:43
Date of creation: Unknown
Punchcutter: Unknown
Materials preserved: None
Type Specimens: Le Bé, Rés. X 1665, folio 20v; Omont, 1887, p. 6;
Literature: None
First occurrence: *Sefer HaShorashim*, Bomberg, Venice 1529?

Le Bé calls this typeface a ‘moyenne glose des Bombergues’ and comments that is ‘très belle et bien taillée, avec meilleur art que celles du Justinian et aultres’. We have already examined a Bomberg Rashi – Hb34 (R) – which has a slightly larger x-height of 2 mm and was used for commentary text. This Bomberg Rashi is very similar in style, but seems to be used mainly for cross references in the margins of the text.

Le Bé also correctly notes that the specimen from the Bomberg edition of what he calls the ‘Sepher Hassarasim’, which is in fact the *Sepher HaShorashim* (the Book of Roots) by David Kimchi. Bomberg printed two editions of this work, in 1529 and 1546.⁷¹¹ There are three separate specimens pasted on the bottom of Folio 20v, and in spite of different appearing sizes to the top specimen, they are most probably the same type, possibly from different copies. The differences can be explained by ink squash or different impressions. The main typeface for the text is Hb35 (S), and the glose has been cast on a larger body so that the lines of marginal glose and text align. This is same in both the 1529 and 1546 edition.

A cursory comparison of the two editions seems to indicate that they are virtually identical, except for different catchwords and possibly different title pages. In the sixteenth century it is very unlikely that type would have been standing over such a long period, thus the later edition was probably completely reset from the earlier model. Only a detailed comparison using a device such as the McLeod Portable Collator would bring out the exact differences between the two editions. What is clear is that same typeface were used in both editions.⁷¹²

It is difficult to agree completely with Le Bé about the aesthetic qualities of this typeface. Smaller Hebrew typefaces rarely bring out the best either in legibility or letterforms, unless they are engraved with what Fournier called *gros oeil*, which is basically a larger appearing size on the same body as a standard size (*oeil*

⁷¹¹ The British Library has both of these editions. The 1529 edition is shelfmark 1936e20 and the 1546 edition is shelfmark 1936e2. See British Museum Dept. of Printed Books, Johnson, and Scholderer, *Short-title catalogue of books printed in Italy and of Italian books printed in other countries from 1465 to 1600 now in the British museum*, p. 211

⁷¹² McLeod, 'ALTVM SAPERE', in *La Bible imprimée dans l'Europe moderne (XVe-XVIIIe siècle)*, ed. by Schwarzbach (Paris: Bibliothèque nationale de France, 1999)

ordinaire).⁷¹³ Le Bé's own attempts at Rashi script, such as Hb5(R), seem more successful in terms of legibility in small sizes. The Rashi on the Estienne type specimen (Hb31 (R)) is also highly legible, in spite of a its 'darker' overall colour.

אָבִיבִידֶה נִזְחֵט יִכְלֵמְסֵנֶפּ בְּקִרְשֵׁת זָאָא

Fig. 4.112: Hb47 (R) Assembled alphabet from Bomberg *Sefer HaShorashim*, 1529 Actual size (BL 1936e20)

אָבִיבִידֶה נִזְחֵט יִכְלֵמְסֵנֶפּ בְּקִרְשֵׁת זָאָא

Fig. 4.113: Hb47 (R) Assembled alphabet from Bomberg *Sefer HaShorashim*, 1529 Enlarged 2x (BL 1936e20)

Fig. 4.114: Page containing specimen of Hb47 (R) from 1529 *Sefer HaShorashim*, Bomberg, reduced 75 per cent (BL 1936e20)

⁷¹³ Pierre-Simon Fournier, 'Manuel Typographique Tome I'(1764) <<http://jacques-andre.fr/ed/index.html#fournier>> [Accessed 6 November 2013], p. 6

Hb48 (S)

Appears on: Rés-X-1665, folio 21
Size: Saint-augustin?
Type Classification: Square Hebrew Sephardic unpointed
Measurements: x-height of 2.3 mm
Date of creation: Unknown
Punchcutter: Unknown
Materials preserved: None
Type Specimens: Le Bé, Rés. X 1665, folio 21
Literature: None
First occurrence: Unknown

This fount is found on the printed specimen on folio 21. The source of this specimen has not yet been identified and there are not enough characters in the specimen to produce an assembled alphabet.



פרקאין עומדין

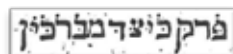

פרקאין עומדין



גמרא

Fig. 4.115: Hb48 (S) Specimen from 1665 folio 21 (Actual size)

Hb49 (R)

Appears on: Rés-X-1665, folio 21
Size: Petit-texte?
Type Classification: Rashi Script unpointed
Measurements: x-height of 1.3 mm; 20:56
Date of creation: Unknown
Punchcutter: Unknown
Materials preserved: None
Type Specimens: Le Bé, Rés. X 1665, folio 21
Literature: None
First occurrence: Unknown

The specimen on folio 20 is a page from what is most likely an index to an as yet unidentified edition of the *Mishnah*. Le Bé adds no annotation to indicate either origin or printer. This typeface is not found in any of the Bomberg editions and was probably not a Bomberg typeface, which is confirmed by the left-pointing termination flag of the final nun. The mem is also distinctive and has a right-hand stroke protruding well below the baseline.



Fig. 4.116: Hb49 (R) Assembled alphabet from Le Bé specimen (Actual size)



Fig. 4.117: Hb49 (R) Assembled alphabet from Le Bé specimen (Enlarged 2x)



Fig. 4.118: Hb49 (R) 20 line specimen from Le Bé specimen (Actual size)

Hb50 (A)

Appears on: Rés-X-1665, folio 22v
Size: Not given
Type Classification: Square Hebrew Ashkenazic pointed and unpointed
Measurements: x-height of 6 mm
Date of creation: Unknown
Punchcutter: Unknown
Materials preserved: None
Type Specimens: Le Bé, Rés. X 1665, folio 22
Literature: Priejs, *Die Basler Hebräischen Drucke*, 1964, p. XV-XXI
First occurrence: *Sefer Tehillim*, Froben, Basle, 1516?

Guillaume I Le Bé produced some 20 Hebrew types following the Sephardic model and cut no types using the Ashkenazic model, the other dominant Hebrew scribal tradition that was represented in print. The only Ashkenazic examples he included in his specimens are those which are found on folios 22v and 23. This preference requires some explanation.

The Ashkenazic script – *Ashkenaz* is the medieval Hebrew word for Germany – originated in northern Europe and was used in the Rhineland, Germany, central and northern France, England, later central and eastern Europe (Poland and Bohemia). The oldest Ashkenazic manuscript dates from the eleventh century.⁷¹⁴ The characteristics of the Ashkenazic style were heavily influenced by the northern European Gothic style, as in the straight strokes, sharp angles, and strong contrast between the thick and thin strokes, and these characteristics varied between the German, French, English and Italian styles.⁷¹⁵

Carlo Bernheimer wrote that ‘the earliest printers took as a model the manuscripts, which they reproduced or imitated the various scripts according to their own taste and the region in which they resided’.⁷¹⁶ There was in fact a mixture of influences in many parts of Italy which led to, for example, the Ashkenazic model being adopted for certain headings, a Sephardic or Italian model for the text and a cursive model for the notes or commentaries.

Gershon Soncino came from a family of German Jews who had settled in Italy in the mid-fifteenth century and took the surname Soncino from the town where Israel – his grandfather – first set up his Hebrew printing press in 1483.⁷¹⁷ However it does appear that the Soncino editions by the mid-1480s were set in mostly Sephardic or Italian style Hebrews. Other early printers, such as Abraham Conat or Meshullam

⁷¹⁴ Trzcinski, ‘*Badania paleograficzne nad pismem hebrajskim sredniowiecznym i nowozytnym (Palaeographic Studies on Medieval and Modern Hebrew Writing)*’, p. 71

⁷¹⁵ Sirat and De Lange, *Hebrew Manuscripts*, pp. 195-203

⁷¹⁶ Bernheimer, *Paleografia ebraica*, p. 107

⁷¹⁷ Marx, ‘*Gershon (Hieronymus) Soncino's Wander-Years in Italy*’, p. 427

Cusi, used types which are much closer to the Ashkenazic model, and it is not clear whether they themselves were of Italian or German origin.⁷¹⁸

Solomon Birnbaum's work is mostly concerned with Hebrew palaeography, but he does comment on the scribal influences in early print. He wrote that:

The type cutters reproduced the letterforms of the contemporaneous manuscripts as closely as possible. Thus the typeface differed according to the type to which the manuscripts belonged. The printers and type cutters would naturally deal with the manuscripts written in the script of their own group, so that from central Italy we would get typefaces of the Italian type, from southern Italy of Sephardic type, and from northern Italy they would generally be of the Ashkenazic type. To reproduce a manuscript meant also to reproduce the style of that manuscript, if it was in Mashait, it was printed in the same style, and if each of its pages contained both Square and Mashait, the printed copy did likewise. The first book in Hebrew characters was printed in Mashait.⁷¹⁹

After some time the Ashkenazic and Italian founts disappeared. Why they did so has still to be explored. The reasons are not to be sought in the script itself but are obviously of another kind. Since then all Jewries have been using the Sephardic type for printing, although the overwhelming majority of books and printers have been and are Ashkenazic.⁷²⁰

Birnbaum's observation that 'Ashkenazic and Italian founts disappeared' applies to Italy and partially to France,⁷²¹ but certainly not to the German-speaking lands and the comment that 'the overwhelming majority of books and printers have been and are Ashkenazic' is debatable. Jews may have followed local traditions, but there were also strong connections among the various Jewish communities.

A curious exception to this finding is the example of a Hebrew alphabet in Palatino's 1540 writing book.⁷²² It is very clearly Ashkenazic in style and the question needs to be asked why an Italian writing master working in Rome in the mid sixteenth century would have chosen this model above a Sephardic one. One possible clue comes from a series of sixteenth-century Jewish gravestones examined in Padua. The author observed that 'in the sixteenth century the square lettering characteristic of the Ashkenazic hand reigned supreme in the Padua cemetery'. And indeed in one gravestone, one can observe the same decorative dots in the thin vertical strokes. It

⁷¹⁸ Freimann and Marx, *Thesaurus typographiae Hebraicae saeculi XV*, pp. 14, 19, 18, 22

⁷¹⁹ For discussion of the term 'Mashait' see page 52 of this thesis.

⁷²⁰ Birnbaum, *The Hebrew scripts*, pp. 270-271

⁷²¹ Note the persistence of Ashkenazic founts in Hebrew printing in Lyons. See Schwarzfuchs, *L'hébreu dans le livre lyonnais au XVIe siècle*

⁷²² Giovanni Battista Palatino, *Libro di M. Giovambattista Palatino cittadino romano : nelqual s'insegna à scriuer ogni sorte lettera, antica & moderna, di qualun que natione, con le sue regole, & misure, & essempli : et con vn breve et vtil discorso de le cifre* (Roma, 1550)

may well be that Palatino had seen similar gravestones in Rome and copied the style as being suitably monumental for his Hebrew alphabet.⁷²³



Fig. 4.119: Hebrew alphabet from the 1550 edition of Palatino's writing book

⁷²³ David Malkiel, 'Renaissance in the Graveyard: The Hebrew Tombstones of Padua and Ashkenazic Acculturation in Sixteenth-Century Italy', *AJS Review* (2013), p. 351



Fig. 4.120: Detail from Jewish gravestone in Padua (Detail of Asher Meshullam tombstone (1.10, d. 1532).

The decline in use of the Ashkenazic model in Italy may also be a reflection of the growth of the new humanistic learning in the Renaissance.⁷²⁴ A. F. Johnson made an important connection between the introduction of roman types and the influence of Humanistic learning and scholars. He noted that ‘by 1480 only ten roman founts are recorded in the presses of Germany, but that their numbers began to increase rapidly after 1490, the printers of Basle in particular leading the way’. He also notes as important that ‘Aldus had no gothic types’.⁷²⁵ A further reason for the persistence of the Gothic form in the German-speaking lands was the connection between the Lutheran Bible in the sixteenth century and use of Texturalis⁷²⁶ as the ‘standard letter in Germany for Bibles and service books’.⁷²⁷

The early use of the Gothic typefaces can also be explained on mechanical grounds. Theodore DeVinne argued that the Gothic character ‘was not so quickly cut, but its broad face, free from hair lines was more readily founded’. He also argued that ‘it could be inked with facility and printed with more evenness of color, and it would not show wear as soon as Romans’. The persistence of Gothic characters in Germany, he

⁷²⁴ For discussion of Humanist interest in Hebrew and in particular the example of Pico della Mirandolo and his Jewish mentors see Manuel, *The broken staff*, pp. 36-44

⁷²⁵ A. F. Johnson, *Type designs: their history and development*. 2nd ed. (London: Grafton, 1934), p. 56

⁷²⁶ The term *textura* or *textur* is related to *Textualis*, which is used to refer to a Gothic book script or black-letter script’. See Michelle Brown and Patricia Lovett, *The historical source book for scribes* (London: British Library, 1999), pp. 87-94. The typographic term used in Germany is *Fraktur*.

⁷²⁷ Johnson, *Type designs: their history and development*, p. 9

maintained, was due to the 'strong prejudice against Roman customs and fashions of all kinds'. This argument does appear to have some bearing on the Hebrew Ashkenazic typefaces, although it does have to be said that they are generally less elegant and aesthetic than those based on the Sephardic model.⁷²⁸

The rapid acceptance of the Italian roman model in France can also be attributed to the influence of Italian culture at the court of François I. It has been said that 'l'Italie est la clef du règne de François I' (1515 – 1547). His role as a patron of the arts has been well documented, and in particular with regard to printing and books.⁷²⁹ The activities of his ambassador in Venice during the years 1540 to 1542, Guillaume Pelicier the Archbishop of Montpellier, present a good example of this keen interest. Pelicier spent enormous energy and funds in seeking out and commissioning manuscript copies of Greek and Hebrew works.

This royal preference for Italian models and his desire to 'emulate the Italian patrons of learning'⁷³⁰ are indicative of the desire to encourage all aspects of classical learning during the reign of François I.⁷³¹ As an illustration, the gallery of François I at Fontainebleau shows the King in classical armour where he is holding 'dans sa main la grenade de l'unité ou bien il chasse l'ignorance de son royaume, afin d'instaurer la règne des arts et des lettres'.⁷³² No one better epitomises this trend than Robert Estienne, under whom Guillaume I Le Bé was apprenticed from the age of 15 in 1539 or 1540.⁷³³ It is recorded that François I was on extremely good terms with Estienne, who was appointed *typographus regius* in 1544.⁷³⁴ Estienne indeed was referred to as 'Robert Estienne, nostre imprimeur ordinaires ès lettres hebraïques, grecques et latines'.⁷³⁵ Vervliet notes that 'in Paris the romanization of vernacular printing started at the very end of the 1520s' and 'it has been suggested that the French court was involved in this change'.⁷³⁶ It thus follows that the Roman letter form began to predominate in this period. It also follows that a 'Latinized' model as opposed to a 'Germanic' model for Hebrew letters would have been the obvious choice for someone such as Le Bé to follow.

Yet another, but perhaps more distant reason for the French preference for Italianized letter models was tied to the wider developing conflict between the Catholic and Protestant worlds in the first half of the sixteenth century. Despite the relatively

⁷²⁸ DeVinne, *The Invention of Printing*, pp. 516-517

⁷²⁹ Jack Lang, *François Ier* (Paris: Editions Perrin, 1997), pp. p. 23 and Chapter V Le Souffle du Minerve, pp. 104-129

⁷³⁰ Linton C. Stevens, 'The motivation for Hellenic studies in the French Renaissance', *Studies in Philology*, 47 (1950), p. 119

⁷³¹ See Arthur Tilley, 'Humanism under Francis I', *The English Historical Review*, 15 (1900) for more discussion of this subject.

⁷³² Gabriel-André Pérouse *et al.*, *L'homme de guerre au XVIe siècle: Actes du colloque de l'Association RHR Cannes 1989* (Saint-Etienne: Publications de l'université de Saint-Etienne, 1992), p. 368

⁷³³ Le Bé, *The Le Bé memorandum*, p. 21

⁷³⁴ Armstrong, *Robert Estienne: Royal Printer*, p. 124

⁷³⁵ *Ibid.*, p. 147 See Chapter V, Estienne at Court for more discussion on this appointment.

⁷³⁶ Vervliet, *The Palaeotypography of the French Renaissance: Selected Papers on Sixteenth-Century Typefaces*, pp. Early Sixteenth-Century Parisian Roman Types, p. 13

strong Calvinist party in France, it has been remarked that 'François n'avait aucun motif politique de soutenir la cause réformée' and 'contrairement à ce que suppose le grand Michelet, cela n'avait que très peu de rapports avec l'esprit de la Renaissance'.⁷³⁷ Furthermore, Henri-Jean Martin has written that 'chacun sait que l'Allemagne et la France divorcèrent, typographiquement parlant, au début du XVI^e siècle' and also notes 'la division de l'Europe typographique en deux mondes qui tendirent désormais à s'ignorer'.⁷³⁸ This offers some explanation as to why Le Bé ignored the Ashkenazic Hebrew model in his documents.

Royal patronage of typography did however occur at the same time in the Holy Roman Empire. The Emperor Maximilian I is said to have arranged a contract with a printer in Augsburg 'pour tailler secrètement un nouveau caractère afin de souligner la spécificité allemande face à l'écriture humanistique'.⁷³⁹ The printer was Johann Schönsperger who was active in Nuremberg and Augsburg and the type was the first appearance of *Fraktur*, used to print a royal prayer book (*Gebetbuch*).⁷⁴⁰ It is interesting that this royal patronage of a 'German' typeface should have occurred *before* the Reformation and is also indicative of the cultural split between the Romance and Germanic worlds.⁷⁴¹ This split was also mirrored in Hebrew typography.

The influence of the Gothic *Textualis* script on the Ashkenazic model is clear. Friedlaender calls the Ashkenazic model the 'hebräische Gotisch'⁷⁴² and Adi Stern calls this an example of the Latinization of Hebrew.⁷⁴³ This term is misleading, yet it may be correct to say that 'the first time Latin script influenced Hebrew was most probably during Gothic times'. The Hebrew Ashkenazic hand, with its strong horizontal stress and diminished vertical strokes, closely reflects the gothic tendency

⁷³⁷ Lang, *François Ier*, p. 165

⁷³⁸ Henri-Jean Martin, 'Politique et typographie à la Renaissance: Histoire d'une divorce', in *Les trois révolutions du livre: actes du colloque international de Lyon/Villeurbanne (1998)*, ed. by Frédéric Barbier and Société des bibliophiles de Guyenne (Genève: Droz, 2001), pp. 71,79

⁷³⁹ *Ibid.*, p. 78

⁷⁴⁰ See also Albert Kapr, *Fraktur: Form und Geschichte der gebrochenen Schriften* (Mainz: Verlag Hermann Schmidt, 1993) for further discussion of this theme.

⁷⁴¹ '1508 erteilte der an das Schriftbild der Fraktur gewöhnte und überaus bibliophile Kaiser dem Augsburger Drucker Johannes Schönsperger den Auftrag, auch eine derartige Type zu schneiden, die dann erstmals 1513 im Maximilianischen » Gebetbuch « zur Anwendung kam. Die monumentale gotische Druckschrift dieses von Albrecht Dürer illustrierten, privaten Breviers für den Kaiser geht auf den Entwurf eines Kalligraphen im Skriptorium des Augsburger Benediktinerklosters zu St. Ulrich und Afra namens Leonhard Wagner alias Würstlin (oder Würstlin, geboren 1453 in Schwabmünchen, gestorben 1522 in Augsburg) zurück. Schon 1507 hatte Meister Leonhard dem Kaiser seine großartige » Proba centum scripturarum una manu exaratarum « gewidmet, einen Kanon von einhundert Schriftarten der mediävalen » lettera antica « und gotischen » lettera moderna «, unter denen auch die » fractura germanica « und eine » semifractura « präsentiert wurde'. See Wolfgang Beinert, 'Fraktur' (2013) <<http://www.typolexikon.de/f/fraktur.html>> [Accessed 29 May 2010]

⁷⁴² Friedlaender, *Die Entstehung meiner Hadassah-Hebräisch*, p. 19. See also Brown, *A guide to western historical scripts from antiquity to 1600*, pp. 80-91 for descriptions of the various categories of the *textualis* hand.

⁷⁴³ Stern, 'Aleph=X, or contemporary Hebrew bad type',

to reduce vertical strokes which leads to a blurring of key recognition factors such as between the letters resh and dalet, heh and chet, kapf and bet. A comparison of the similarity between the Ashkenazic writing hand and textualis is shown in the figure below:⁷⁴⁴

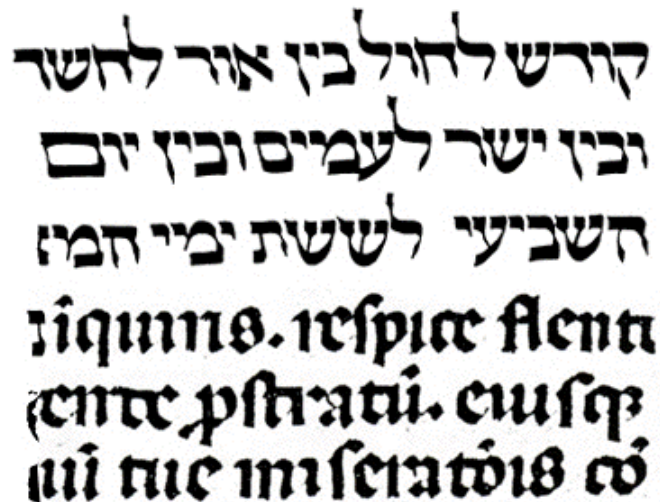

Fig. 4.121: Fourteenth-century Ashkenazic scribal and sixteenth-century printing compared (From Adi Stern, *Aleph=X, or contemporary Hebrew bad type*, 2004)

A further comparison of the close similarity between a fourteenth-century Ashkenazic manuscript hand and a sixteenth-century Ashkenazic printing type (1527) is shown in the figure below. The same strong horizontal stress is present, but the baselines of the letters have been flattened out and the left hand slant made less prominent.⁷⁴⁵



Fig. 4.122: Comparison between Ashkenazic scribal hand and printing type (Friedlaender, *Die Entstehung meiner Hadassah-Hebräisch*, p. 18) Reduced

Malachi Beit-Arié described the influence of the scribal models used in early Hebrew typefaces as follows: ‘the local Italian scripts, the square one which was rooted in the Ashkenazic type of script, and the semi-cursive one which was introduced by the

⁷⁴⁴ *Ibid.*

⁷⁴⁵ Friedlaender, *Die Entstehung meiner Hadassah-Hebräisch*, p. 18

Sephardic-Provençal printer Avraham Conat, were rapidly rejected from Italian Hebrew printing, which adopted the Sephardic types of script, introduced by the Ashkenazic printers of the Soncino family'.⁷⁴⁶ This involved making a selection and choice of locally available models, and this selection 'was not influenced by the printer's own origins and handwritings'.⁷⁴⁷

Evidence for the predominance of the Sephardic scripts has come from yet another source. A study of 150 surviving Talmudic and Midrashic manuscript fragments which were found in Italian Archives and libraries has shown that Sephardic scripts accounted for nearly 55 per cent of the total. Ashkenazic hands accounted for 25 per cent, oriental hands accounted for two per cent, whereas Italian hands accounted for 18 per cent. These manuscripts fragments date from the tenth to the fifteenth centuries and consist of recycled pages which were used as bindings or reinforcement for books and registers, generally in the 1550s, following the confiscations and burnings of the Talmud in 1553. One conclusion from these findings is that there was a clear preference in Italy for the Sephardic hand, even prior to the advent of print.⁷⁴⁸ It is also interesting to note that three major Hebrew scribal hands – Italian, Sephardic and Ashkenazic – are found in the manuscript fragments found in the bindings of north central Italy, whereas in the recycled fragments found in Germany the hands are exclusively Ashkenazic, and in the Sephardic regions they are all in the Spanish or Sephardic style.⁷⁴⁹

What was known as the 'Gothic' style, a pejorative name perhaps indicating an Italian view of its origins,⁷⁵⁰ became a very widespread script in many countries including England, northern France, the Netherlands, the German speaking lands, Italy and Spain, whether it was known in its various permutations as Textura, Lettre de forme, Fere Humanistica, Gotico-Antiqua, Rotunda, Littera Moderna, Bastarda, Lettre Bâtarde, Schwabacher or Fraktur.⁷⁵¹ One of the major factors which appears to have altered the preference to Roman is the association with the New Humanistic learning, particularly in Italy, where it became known as the 'littera antiqua', a description still used in German typography to refer to Roman.⁷⁵² Hebrew types mirror this trend, but coming from different sources. The critical period was the early sixteenth century and typographic developments in Paris, which relate directly to the typefaces produced by Guillaume I Le Bé.

⁷⁴⁶ Malachi Beit-Arié, *The makings of the medieval Hebrew book: studies in palaeography and codicology* (Jerusalem: Magnes Press, Hebrew University, 1993), p. 260

⁷⁴⁷ *Ibid.*, p. 255

⁷⁴⁸ Mauro Perani and Enrica Sagradini, *Talmudic and midrashic fragments from the Italian Genizah: reunification of the manuscripts and catalogue* (Firenze: La Giuntina, 2004), pp. 7-13, 18, 125, 127

⁷⁴⁹ Mauro Perani, 'The death and rebirth of the Hebrew Manuscripts: their reuse as book bindings and recent rediscovery', in *The Italian Genizah. General Survey and Case Studies* (Leiden - Boston: Brill, 2008), p. (p.8)

⁷⁵⁰ Kapr, *Fraktur: Form und Geschichte der gebrochenen Schriften*, p. 13

⁷⁵¹ Johnson, *Type designs: their history and development*, pp. Chapter 1, Gothic Types, pp. 5-47

⁷⁵² *Ibid.*, p. 48

The Le Bé specimen on Folio 22v is the entirety of page 70 from the 1529 edition of Nicolas Clénard's *Tabula in grammaticen hebraeam*, printed by Theodore Martens in Louvain.⁷⁵³ The author, Nicolas Clénard (c. 1494 – 1542), was a Flemish humanist, traveller, Hebraist and Arabist. He was also known as Nicolas Cleynaerts or Nicolaus Clenardus.⁷⁵⁴ This 6 mm Hebrew typeface used by Martens is most probably what Prijs calls Qa and which was first used in Konrad Pellikan's *Sefer Tehillim* printed by Johann Froben in 1516.⁷⁵⁵

Theodore Martens, also known by his Flemish name of Dirk or Thierry Martens, was active as a printer from the 1470s until his death in 1534 in Alost, Antwerp and Louvain. In his long career, he was possibly the first to introduce Greek type in the Low Countries in 1512 and printed at least two works using Hebrew.⁷⁵⁶ The first was the *Grammatica hebraica* of Jan Van Campen d'Overysse (Joannis Campensis) in 1528 and the second the work by Nicolas Clénard. Van Iseghem maintained that Martens cut at least some of his founts, but Vervliet does not support this claim. The Hebrew used in the Le Bé specimen is of Swiss origin, and it is not clear where the Romans used on the page came from.

The distribution of this Hebrew fount, at least in the Frobenius Hebrew editions in Basle, appears quite frequently during the sixteenth century. The fact that Martens had it in his press in Louvain in 1529 shows the speed with which types could be spread. It is also worth comparing this Hebrew to the Ashkenazic Hebrew used in the first edition of Johannes Reuchlin's *De rudimentis hebraicis*, printed by Thomas Anshelm in Pforzheim in 1506. It is identical in size, but not in detail. For example, the left hand stroke of the mem in the Pforzheim edition does not touch the baseline stroke, whereas it descends below it in the Martens example, and note difference in treatment to the ascender termination of the lamed. However it is possible that the Pforzheim type was a model for the example shown in Le Bé.⁷⁵⁷

⁷⁵³ See Charles Henry Timperley, *A Dictionary of Printers and Printing, with the Progress of Literature, ancient and modern: bibliographical illustrations, etc* (London, 1839), p. 258. See also A. F. van Iseghem, *Biographie de T. Martens d'Alost ... suivie de la bibliographie de ses éditions* (Malines: P.J. Hanicq, 1852), pp. 46-51. See also Vervliet and Carter, *Sixteenth-century printing types of the Low Countries*, pp. 57, 238-239, 292-293

⁷⁵⁴ See Abel Lefranc, 'Nicolas Clénard, humaniste belge, et les commencements du Collège de France', *Comptes-rendus des séances de l'Académie des Inscriptions et Belles-Lettres*, 85e année, N. 5 (1941) and Alastair Hamilton, *William Bedwell the Arabist, 1563-1632* (Leiden: Published for the Sir Thomas Browne Institute by E J Brill, 1985), p. 70

⁷⁵⁵ Joseph Prijs, *Die Basler hebräischen Drucke, 1516-1828* (Basel: Sopher-Verlag, 1952), pp. XVIII-XIX

⁷⁵⁶ van Iseghem, *Biographie de T. Martens d'Alost ... suivie de la bibliographie de ses éditions*, p. 164

⁷⁵⁷ Kestenbaum & Company, 'Fine Judaica: Printed Books, Manuscripts, Autograph Letters, Graphic & Ceremonial Art To Be Auctioned On Thursday, January 31st', p. 62



Fig. 4.123: Hb50 (A) Assembled alphabet from *Tabula in grammaticen hebraeam*, 1516. Actual size (Amsterdam University Library Special Collections, RON A-4732)

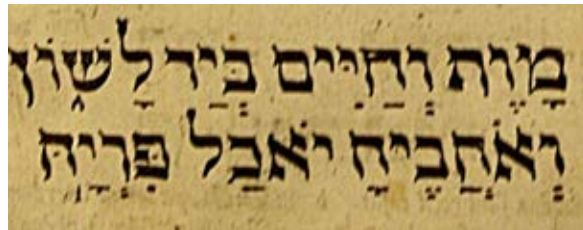

Fig. 4.124: Hb50 (A) Lines of pointed setting from the colophon of *Tabula in grammaticen hebraeam*, 1516. Actual size (University of Amsterdam Special Collections, RON A-4732)

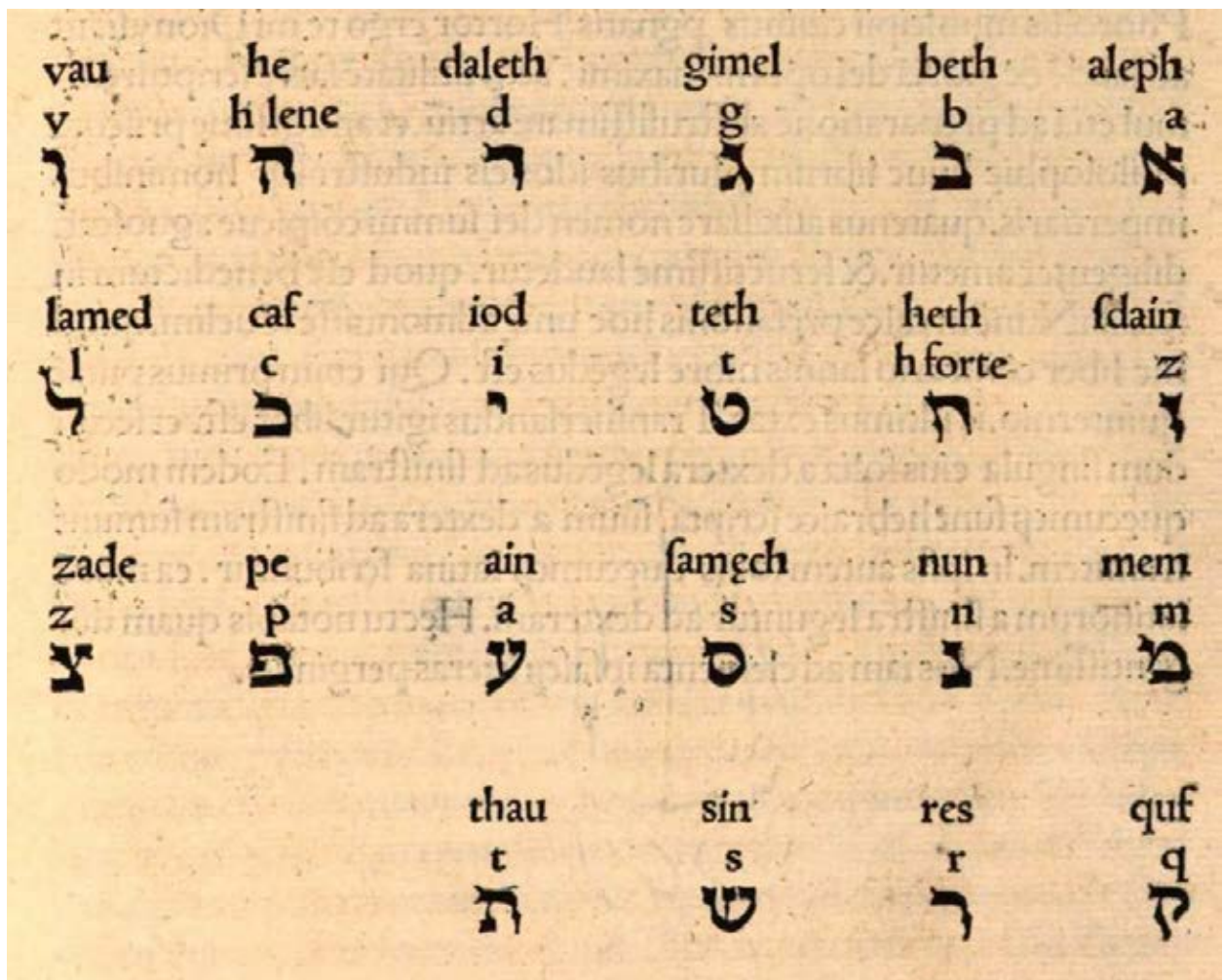

Fig. 4.125: Hebrew Alphabet from Reuchlin, *De rudimentis Hebraicis*, Thomas Anshelm, Pforzheim, 1506, p. 5 (VD16 R 1252) reduced to same size as Hb50 (A)

Attributions for this typeface in printed editions:

Sefer Tehilim, Basle, Johannes Froben, 1516 (e-rara)

Sefer Tehilim, Basle, Johannes Froben, 1523 (e-rara)

Mikre dardeqe/Dictionarium hebraicum, Basle, Johannes Froben, 1525 (e-rara)?

Qohelet/Ecclesiastes, Basle, Johannes Froben, 1523 (e-rara)?

Kitsur HaDikduk/Compendium Hebr. Grammaticae, Basle, Johannes Froben, 1527 (e-rara)?

Sebastian Münster, *Arukh/Dictionarium Chaldaicum non tã[m] ad Chaldaicos interpretes*, Basle, Johannes Froben, 1527 (Prijs, No. 26)

Nicolas Clénard, *Tabula in grammaticen hebraeam*, Louvain, Theodore Martens, 1529

HaVikuach/Christiani hominis cum Iudaeo pertinaciter prodigiosis suis opinionitus, Basle, Johannes Froben, 1529 (e-rara)

Sefer Hadikduk/Grammatica Hebr. Eliae Levitae Germani, Basle, Johannes Froben, 1532 (e-rara)?

Arba'ah veEsrin, Basle, ex officina Frobeniana, 1536 (e-rara)?

Sefer Hadikduk/Grammatica Hebraea Eliae Levitae Germani, Basle, apud Hieronymum Frobenium et Nicolaum Episcopium, 1537 (e-rara)

Sefer Tehilim, Basle, apud Hieronymum Frobenium et Nicolaum Episcopium, 1538 (e-rara)

Isagoge elementis perquam succinta in hebraicam linguam, Basle, per Hieronymum Frobenium et Nicolaum Episcopium, 1540 (e-rara)?

Sefer Tehilim, per Hieronymum Frobenium et Nicolaum Episcopium, Basle, 1563 (e-rara)

This list is taken from the Swiss digitized libraries site e-rara, and is by no means comprehensive, but gives an indication of its use. Prijs in *Basler Hebräischen Drucke* is much more comprehensive in his coverage.

Hb51 (A)

Appears on: Rés-X-1665, folio 22

Size: Not given

Type Classification: Square Hebrew Ashkenazic pointed

Measurements: x-height of 4.5 mm, 20:177 (Unpointed), 20:166 (vocalised)

Date of creation: Unknown

Punchcutter: Unknown

Materials preserved: None

Type Specimens: Le Bé, Rés. X 1665, folio 22

Literature: De Rossi, *Annales Hebraeo-typographici* sec. XV, p.

First occurrence: *Selihot*, Piove di Sacco, Meshulam Cusi, c. 1475?

This type specimen, if that is what it is, may prove to be the oldest type specimen of Hebrew that has been found to date. This typeface is first seen in the editions printed by Meshulam Cusi and his sons in Piove di Sacco in 1475.⁷⁵⁸ The edition of *Arba'ah Turim* is dated precisely in the colophon to the 3rd July 1475 and the edition of *Selihot* to about 1475. It is probably the oldest dated Hebrew Incunabula known and one can see that he used an Ashkenazic scribal hand as the model for this typeface.⁷⁵⁹ There is, for example, a Hebrew Bible produced in Germany in 1294 and written in an Ashkenazic square script which contains both the aleph/lamed and 'Yehovah' ligatures shown in the Le Bé specimen.⁷⁶⁰ The aleph/lamed ligature persisted as a common sort well into the nineteenth century, and indicated both the name of God (El), as well as being used as a contraction for example in the Hebrew spelling of Israel. The ligature for the name God as seen in some Incunabula editions appears to be an early form of the abbreviation *Yod-Yod* (יוד) and does not seem to have lasted much beyond the Incunabula period. This is an abbreviated form of the Tetragrammaton (יהוה), 'the divine name associated with the attribute of mercy'.⁷⁶¹

⁷⁵⁸Piove di Sacco is a small village in the region of Veneto, about 25 kilometres southwest of Venice and about 20 kilometres southeast of Padua.

⁷⁵⁹ See for further details and discussion

'Incunabula' (<http://www.jewishvirtuallibrary.org/jsource/judaica/ejud_0002_0009_0_09521.html> [Accessed 4 October 2012], A. K. Offenbergh and C. Moed-van Walraven, *Hebrew incunabula in public collections: a first international census, Bibliotheca humanistica & reformatrica* ; v.47. (Nieuwkoop: de Graaf, 1990) and Herrmann Meyer, 'Bibliographical notes on the historical development of Hebrew typography', in *Thesaurus typographiae Hebraicae saeculi XV = Hebrew printing during the fifteenth century (Ha-Qtsar li-melekhet ha-defus ha-'ivri ha-rishonah ad shenat r"ss)* ed. by Aron Freimann and Moses Marx (Jerusalem: The Universitas Booksellers, 1969)

⁷⁶⁰ This is MS. Urb. Ebr. 1 in the Vatican library. See Eugene Tisserant, *Specimina codicum orientalium, Tabulae in usum scholarum* (Bonnae: A. Marcus et E. Weber, 1914) and Benyamin Richler, *Hebrew Manuscripts in the Vatican Library: Catalogue* (Rome: Bibliotheca Apostolica Vaticana, 2008). These two ligatures are also used in the British Library *Ashkenazi Haggadah*, which is dated to the mid-fifteenth century. See Goldstein, Simeon, and Worms, *The Ashkenazi Haggadah*, p. 15

⁷⁶¹ Savage, *A Dictionary of the Art of Printing*, pp. 311-321. See also John J. Parsons, 'Rabbinical Halakhah - Regarding writing the Hebrew Names of God' (<http://www.hebrew4christians.com/Names_of_G-d/About_Writing/about_writing.html> [Accessed 7 April 2014] and Jeremy Schonfield, *Undercurrents of Jewish prayer* (Oxford: Littman Library of Jewish Civilization, 2006), pp. 118, 130

The type was used by Soncino for his edition of *Selichot* printed in Barco, with the addition of vowels either printed or added by hand.⁷⁶² The fount was also cast on a smaller body, as the 20 line count for this vocalised setting is 20:166. Both ligatures can be seen in this edition. Giovanni de Rossi described the types in the *Arba'ah Turim* as being 'all square and German', meaning Merooba and Ashkenazic.⁷⁶³ He says nothing more about the origin of the type, nor does Meshullam Cusi in the colophon to *Arba'ah Turim*. Cusi wrote that he had produced this volume 'without a pen stroke' and 'without a scribe'.⁷⁶⁴

The possible appearance of this type in André Wechel's Frankfurt Bible edition of 1575 is curious and raises questions as to how this typeface could have survived for such a long time and how Wechel might have obtained it. He uses it in the third volume (*Bibliorum pars tertia*) as initial letters for Lamentations 1 and 3, and apparently nowhere else in the other five parts. One possible hypothesis is that Wechel obtained this type in Frankfurt after he re-established himself there, following his escape from Paris, and had none of his Paris Hebrews to hand.

The text for the Le Bé specimen is from Jeremiah 4: 1-2.



Fig. 4.126: Hb51 (A) Assembled alphabet from Le Bé specimen and Piove di Sacco edition 1475 (Actual size)

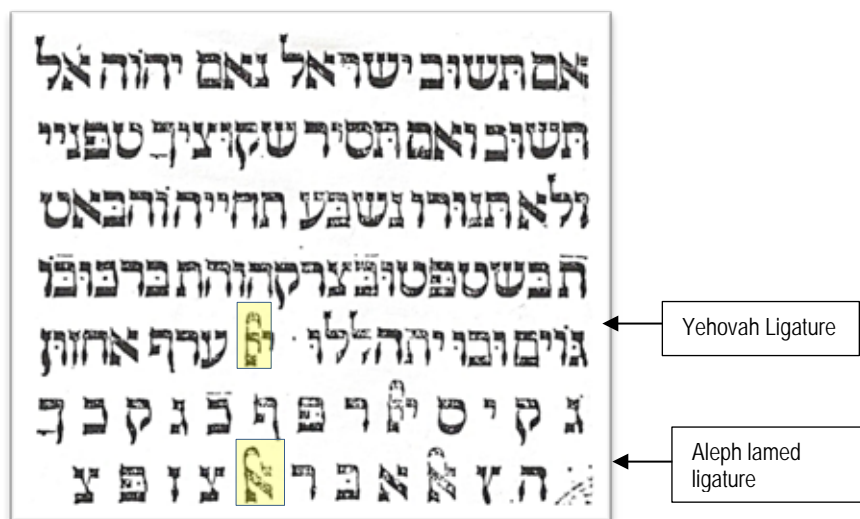

Fig. 4.127: Hb51 (A) Le Bé specimen folio 22 (Actual size)

⁷⁶² See discussion of this possibility on page 316.

⁷⁶³ Giovanni Bernardo De Rossi, *Annales Hebraeo-typographici sec. XV* (Parmae, 1795), p. 6 'Tres occurrunt characteres, quadrati omnes et germanici, alter minusculus, non adeo inflexus nec inelegans, quo textus, major alter, rudior et incomptior, quo tituli et prima verba, tertius intermedius ac rarior, quo initialia quaedam praefationum vel constitutionum vocabula sunt exarata'.

⁷⁶⁴ Amram, *The makers of Hebrew books in Italy*, pp. 25-26



Fig. 4.128: Page from MS. MS. Urb. Ebr. 1 in the Vatican library (From Tisserand, *Specimina codicum orientalium*, 1914) Note highlighted aleph/lamed and yehovah ligatures, and the 'nun afukh' used to fill out lines. (Actual size)

לך ית' הצדקה ולנו בושת הפנים מה נת
נתאוננו ומה נאמר מה נדבר ומה נצ
נעטרק נחפשה דרכינו ונחקורה ונשובה אל
אליך כי ימינך פשוטה לקבל שבים
לא בחסד ולא במעשים באנו לפניך כדלים
וכרשים דפקנו דלתיך דלתיך דפקנו רחום ו
רחימו נא אל תשיבנו ריקם מלפניך מלפניך
מלבינו ריקם אל תשיבנו כי אתה שומע תפ
תפילה

שומע תפילה עדיך כל בשר יבאו יבא כל
בשר להשתחוות לפניך ית' יבאו וישתחו
לפניך ית' ויכבדו לשמך באו נשתחוה ונברע
נברכה לפני ית' עושינו באו שעריך בתורה ח
חצרותיו בתהילה הודו לו ברבו שמו הנה ב
ברכו את ית' כל עבדי ית' העומדים בבית ית'
בלילות שאי ידיכם קודש וברכו את ית' ברכו
ית' מלאכיו גבורי כח עושי דברו לשמוע בק
בקול דברו ברכו ית' כל עבאיו משרתיו עושי
דעונו ברכו ית' כל מעשיו בכל מקומות ממ
ממשלתו ברכו ית' וכל קרבי את ש
שם קדשו ית' אלהי גדלת מאד הוד והדר לב
לבשת כי שם ית' אקרא הבו גודל לאהינו נב

Fig. 4.129: Hb51 (A) Example from Meshullam Cusi's *Selihot*, c. 1580. From Freimann, *Thesaurus typographiae Hebraicae saeculi XV*, Plate A3,1. Note the use of both ligatures, one of them possibly damaged.

אזא השם הנכבד והגורא סלחנא לעוונ עם זי יצרת תהלתך
לספרת בעבוד כבוד שמך הטה אונך אל התפלה ואל
התחנה אשר עבדיך מתפללים לפניך " גשתי ביום זה להודות
לשמך ולהתודות הטאתי וחטאת עמך " דברי תחנתי בתפילי
מול ארון בריחך " ואתה תשמע השמים מבון שבתך " הן
עמדתי מונג מדעיד מפני כבוד עוונותי כי רבו פשעי ועצמו
חטאתי " ולקחתי דברים עמי שהורית לעניו מקרם בהם ל
לרצותך מעונה אלהי קרם " זעקת תחנתי תבא נא עדיך ולא
תשיב פני קטן של שליח צבור עבדיך " חנון חתר צה לקול זעקת
מחנניך תבין לבם תקשיב אונך " טוב דרכי רחמיך לא
תמצע ממנו בגודל חסדך התנהג עמנו " יחשבנא בקרבן לפניך
צום תעניתנו והצילנו וכפר על חטאתינו " כפר נא למתוודים
לפניך חטאתם גקם וטהרם מפל טומאותם " לא יבושו מסברם
כל המפילים לפניך תחנתם ושמעת מן השמים את תפלתם
מחל נא למבקשים היום לפניך מחילה ותשליך כל חטאתם
בעמקי מצולה נא באז לאיש חמורות הקשבת שוועה בן עתה
תפלת עבדיך ון שמעה " סלח נא ושא נא לפשע עמך ושוב
מהרון אפך ושכך מהם זעמך עבוד ידעו כל באי עולם כי ע
עמך הסליחה חטאת מבקשי פניך ון סלחה " פקוד נא
ברחמים את סגולתך לא תבוזה ולא תשקץ ענות עניי עררך
ציון תרחם ובירושלים עוד תבחר ון הקשיבה ועשה אל תאחר
" קבץ נא נפוצי צאנך ופקוד גפן זאת וכנה אשר גטעה ימינך
רומה והגשא לאסוף גרתי לא למענינו כי אם למענך אלהי
שמע נא והאזינה לקול שועתנו והעתר לנו בתפלתנו " תשוב

Fig. 4.130: Hb51 (A) Example from Soncino's *Selihot*, c. 1596. Note the highlighted ligatures. Actual size (From Freimann, *Thesaurus typographiae Hebraicae saeculi XV*, Plate A83,1)

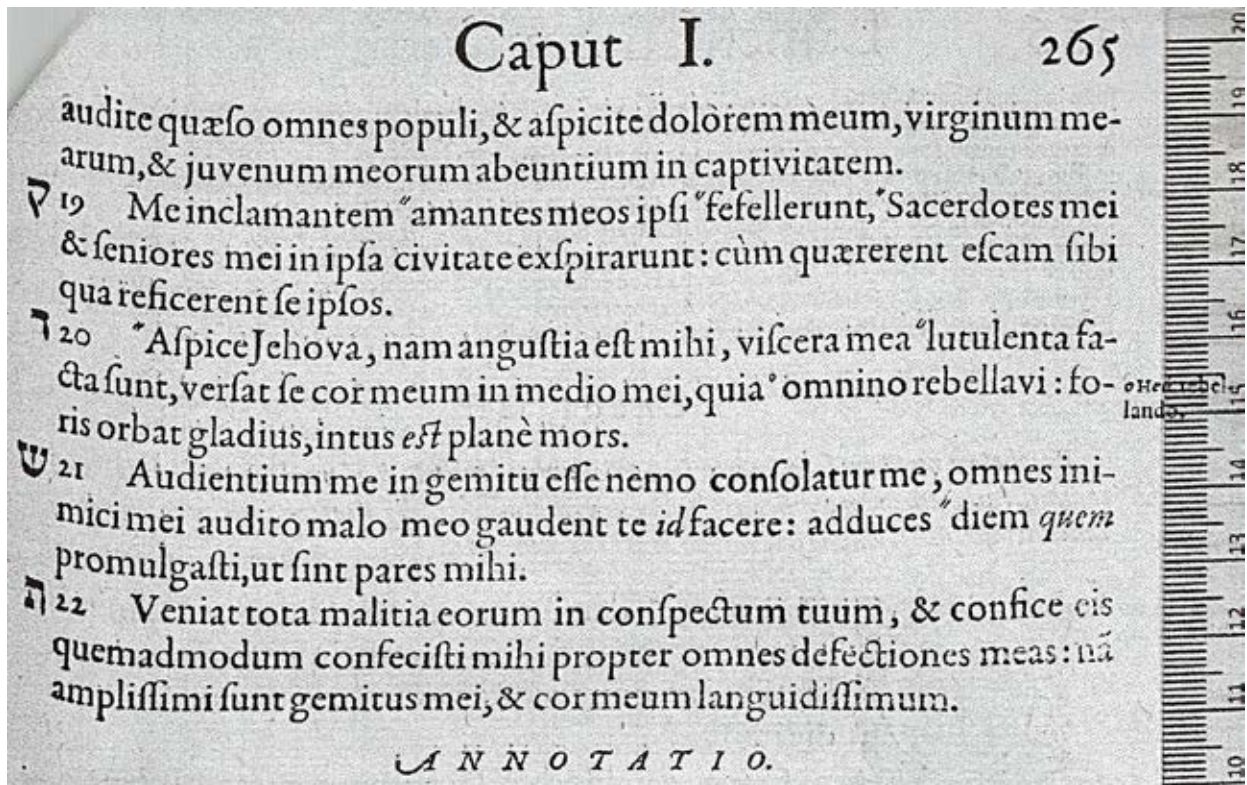

Fig. 4.131: Part of page from Wechel's *Bibliorum pars tertia*, showing the use of Hb51 (A) as initial letters in the margin. (BL 463c8)

Attributions for this typeface in printed editions:

- *Selihot*, Piove di Sacco, Meshulam Cusi, c. 1475
- *Arba'ah Turim*, Piove di Sacco, Meshulam Cusi, July 1475
- Eldad HaDani, *Sefer Eldad*. Piove di Sacco, Meshullam Cusi and sons, c. 1480
- *Selihot*, Barco, Moses b. Gershom Soncino, 1496
- *Bibliorum Pars Tertia*, Frankfurt, André Wechel, 1569?

Hb52 (A)

Appears on: Rés-X-1665, folio 23

Type Classification: Square Hebrew Ashkenazic pointed hand

Measurements: x-height of 5 mm

Materials preserved: None

Type Specimens: Le Bé, Rés. X 1665, folio 22

Literature: Birnbaum, no. 343, Beit-Arié, Sirat, and Glatzer, *Codices Hebraicis litteris exarati quo tempore scripti fuerint exhibentes*, Vol. IV, Manuscript 91

This specimen is not a typeface at all, but an example of a calligraphic hand. Le Bé has not added any annotations to these two specimens, so we are left to speculate as to why he included them in this document. These two documents are assembled collections, and in that sense Le Bé inserted specimens of type and scribal hands which he had collected over the years and which appealed to him. This particular scrap of manuscript is from an Ashkenazic Machzor and is a fragment from the *selihah* אל דביר קדשך ידינו נשואות (To your holy sanctuary our hands are raised).⁷⁶⁵

This hand is closest to Birnbaum's number 343, which he classifies as a thirteenth-century Square Ashkenazic hand. The thick and thin strokes are strongly differentiated, and the terminations are thin 'flicks' made with the side of the pen. Note the gimmel and the tsadde in the Le Bé specimen, which are very close in style to the Birnbaum 343.⁷⁶⁶ This hand is also very close to MS Bologna, *Biblioteca Universitaria* 2209/2208, which is dated in its colophon to 1193. The close similarity to the Le Bé specimen can be seen in the squared termination to the lamed, the gimmel, the fine vertical termination to the chet, and the oblique downstroke of the tsadde.⁷⁶⁷



Fig. 4.132: Hb52 (A) Specimen from Le Bé, Rés. X 1665, folio 22 (Actual size)

⁷⁶⁵ See glossary. I am grateful to Malachi Beit-Arié, Ludwig Jesselson Professor emeritus of Codicology and Palaeography at the Hebrew University of Jerusalem for this identification and clarification of this text, as well as for the identification of Hb53 (A).

⁷⁶⁶ Birnbaum, *The Hebrew scripts*

⁷⁶⁷ Malachi Beit-Arié, Colette Sirat, and Mordechai Glatzer, *Codices Hebraicis litteris exarati quo tempore scripti fuerint exhibentes = Otsar ha-mitshafim ha-ivriyim: kitve-yad bi-khetav ivri mi-yeme ha-benayim be-tsiyune ta'arikh. Tome IV, De 1144 à 1200* (Turnhout: Brepols, 2006), pp. 108-115

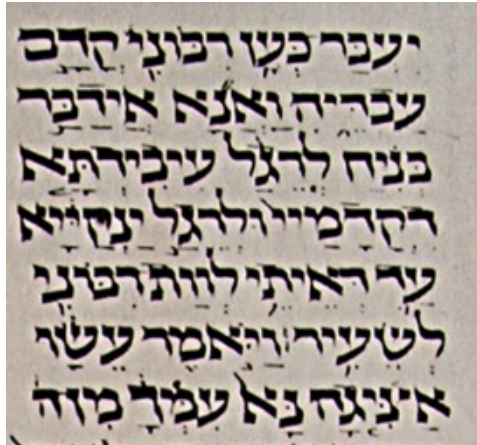

Fig. 4.133: Sample from Birnbaum, No. 343 (Actual size)

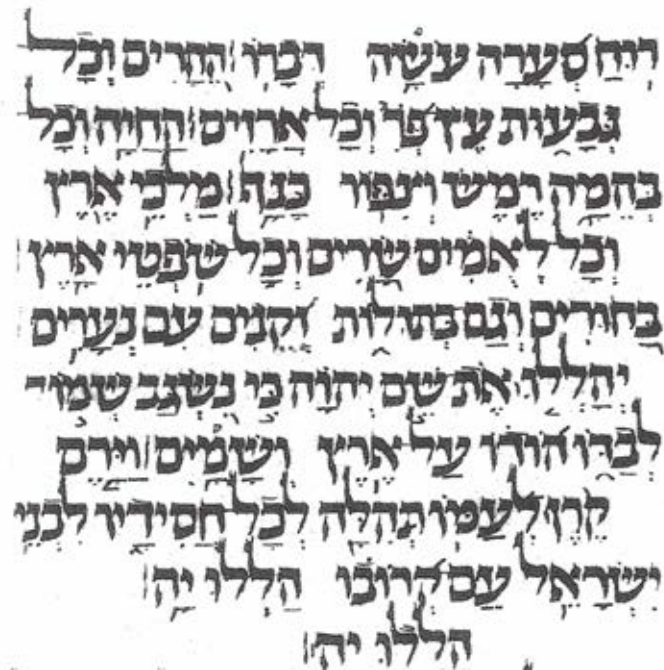

Fig. 4.134: Detail from f. 43v of MS 2209, 2208 from the Biblioteca universitaria, Bologna. Actual size (From Beit-Arié and Sirat, *Codices Hebraicis litteris exarati quo tempore scripti fuerint exhibentes*, Manuscript 91, p. 114.)

Hb53 (A)

Appears on: Rés-X-1665, folio 23

Type Classification: Square Hebrew Ashkenazic pointed hand

Measurements: x-height of 3 mm

Materials preserved: None

Type Specimens: Le Bé, Rés. X 1665, folio 22

Literature: Birnbaum, no. 343

The second calligraphic specimen on this folio shows an example of a fifteenth-century semi-cursive script. The closest model for this hand are the various samples of Ashkenazic semi-cursive script shown in Birnbaum. The text is once again a fragment of an Ashkenazic selihah for Yom Kippur similar to אלו אזכרה⁷⁶⁸

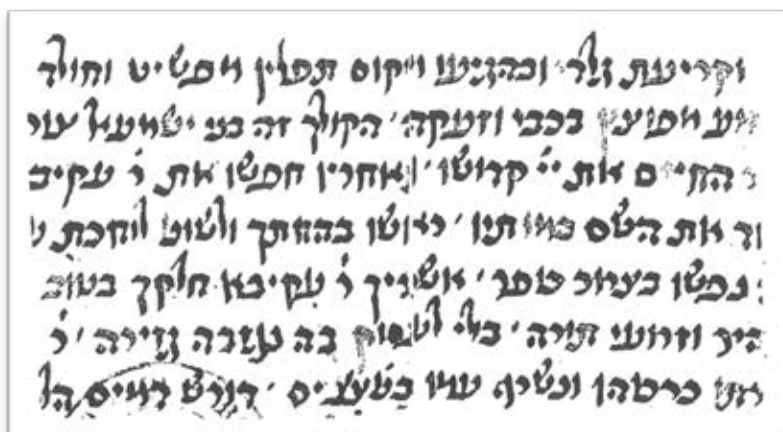

Fig. 4.135: Hb53 (A) Le Bé specimen (Actual Size)

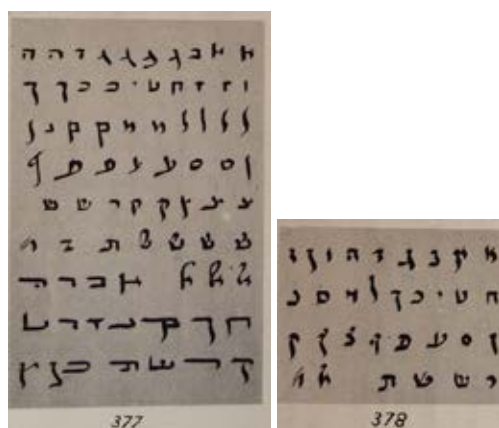

Fig. 4.136: Samples of an Ashkenazic semi-cursive Script from Birnbaum, *The Hebrew Scripts*

⁷⁶⁸ 'Those I will remember' in Hebrew

Chapter 5: Synthesis and Discussion

The main object of this thesis has been to examine and analyse the Hebrew types found in the two documents compiled by Guillaume I Le Bé which are held in the Bibliothèque nationale de France in Paris. The aim of this final chapter is to summarise these findings and put forward some tentative hypotheses for the career of Guillaume I Le Bé as a punchcutter, and his *modus operandi* as a type founder, paper merchant, printer and businessman.

In addition, one further goal of this thesis has been to locate Guillaume I Le Bé in his historical context. This desideratum was described by Geneviève Guillemint-Chrétien, conservateur en chef at the Bibliothèque nationale de France, when she wrote about Le Bé that ‘cependant, l'étude à travers les documents d'archives de leur situation sociale, familiale et même professionnelle reste largement à faire. Si leur réputation repose sur leur fonderie et son influence sur l'art typographique européen, c'est le commerce du papier qui assure leur enrichissement au XVI^e siècle et permet à Guillaume I Le Bé de prendre rang par les personnalités notables des métiers du livre, d'accroître peu à peu son patrimoine immobilier et détenir des créances sur les principaux libraires de son temps. Cette aisance financière explique la capacité des Le Bé à acquérir poinçons et matrices des autres graveurs parisiens’.⁷⁶⁹ The 1598 *Inventaire après décès* provides some answers to these questions, however provisional.

This comment also raises the question to what degree Le Bé based the success of his typefoundry on his business as a paper merchant. The *Le Bé Memorandum* contains a comment that Guillaume I Le Bé paid a visit to Robert Estienne in Geneva on his return to Paris from Italy in 1550. On that occasion Estienne gave him ‘lettres de Recommandation aux amis quil cognoissoit en France et mesme apporta lettres de Recommandation a Guillaume le bé son père, marchand papetier à Troyes’. The message of these letters was a request to Guillaume I Le Bé’s father in Troyes that he continue to supply paper to Estienne’s sons Robert and Charles, who had remained in Paris.⁷⁷⁰ Thus we have very solid evidence that Guillaume I Le Bé intended to operate at least partly as a paper merchant once settled in Paris.

The searches conducted by Philippe Renouard for documents relating to the Parisian printing trades also show a total of 71 individuals identified as *Papetiers*, and 68 as *Parchemeniers*.⁷⁷¹ Although the period sampled – between 1450 to 1600 – covers both the earlier Incunabula period and the more technically advanced sixteenth century, these numbers appear to confirm the assessment that ‘manuscripts continued to be written and illuminated long after the press arrived in Paris in 1470’

⁷⁶⁹ Pascal Fouché, Daniel Péchoin, and Philippe Schuwer, *Dictionnaire encyclopédique du livre. Volume 2, E-M* (Paris: Cercle de la librairie, 2005), p. 702

⁷⁷⁰ Le Bé, *The Le Bé memorandum*, pp. 21-22. The author of this memorandum, Guillaume II Le Bé, adds that he had kept this letters for a long time, but had destroyed them, ‘ne jugeant pas estre nécessaires’.

⁷⁷¹ See also page 24 in this thesis.

and that ‘it was the *libraire* who was the critical figure linking the world of the manuscript book and the printed book era’.⁷⁷² Paper had been manufactured in Europe from the late twelfth century and yet, well until the fourteenth century many countries in Western Europe were dependent on Italian paper mills’.⁷⁷³ There is a document from 1432 which records the purchase of some 20 reams (*rames*) of paper from a Milanese merchant to a merchant in Avignon. The first French paper mills in Troyes are mentioned in a document from 1348 and Alibaux writes that ‘c’est d’Italie sûrement que nous est parvenu cet art nouveau (i.e. le papier) sur presque tous les points où il s’est implantés au XIVE siècle’.⁷⁷⁴ The availability of paper was thus well established when printing appeared, and in Britain at least ‘the price of paper had in effect halved by the middle of the century (i.e. 1450) and then halved again by 1500’.⁷⁷⁵

Renouard’s listings of paper merchants makes mentions mainly of those who were a *papetier*, *marchant papier*, or *papetier-juré en l’Université*. The main links to other book trades are the occasional combined mentions of a *marchand libraire et papetier* – for example Etienne Bourdon, Jean Canyvet, Jean Ricouard and Guillaume Roulard – or the mention of Guillaume I Le Bé, as a *papetier et fondeur* in 1572. Yet the dominant *métier* is not always clear and in several instances Renouard admits that ‘nous ne savons si ce fut comme imprimeur, libraire, relieur ou papetier’, thus underscoring the fluidity of professions during the sixteenth century. As previously discussed, Le Bé’s entry into the profession of punchcutter was no doubt through his family connections to the Estienne family.⁷⁷⁶

It is relevant at this point to examine Le Bé’s output as a punchcutter compared with his contemporaries in the sixteenth century. The most comprehensive and authoritative analysis to date is that of Hendrik Vervliet’s *Conspectus*. He studied and listed the output of 17 major French punchcutters including Guillaume I Le Bé, and another 11 minor punchcutters, whose work ‘has not been identified for certain or not included in his review’. The 17 major punchcutters are as follows with their known birth and death dates or dates when they were known to be active (*fl.*):⁷⁷⁷

<i>Punchcutter</i>	<i>Dates</i>	<i>Total Production</i>
Jean Vatel	<i>fl.</i> 1513 to 1522	3
Simone de Colines	<i>c.</i> 1490 to 1546	25
Maître Constantin	<i>c.</i> 1500 to 1533	6

⁷⁷² Rouse and Rouse, *Manuscripts and their makers*, pp. 229, 331

⁷⁷³ Erik Kwakkel, 'A New Type of Book for a New Type of Reader: The Emergence of Paper in Vernacular Book Production', *The Library*, 4 (3) (2003), p. 120

⁷⁷⁴ Henri Alibaux, *Les Premières Papeteries françaises* (Paris: Les Arts et le Livre, 1926), pp. 106-109, 192

⁷⁷⁵ R.J. Lyall, 'Materials: The Paper Revolution', in *Book production and publishing in Britain, 1375-1475*, ed. by Jeremy Griffiths and Derek Pearsall (Cambridge [England] ; New York: Cambridge University Press, 1989), p. 11

⁷⁷⁶ Renouard, *Documents sur les imprimeurs, libraires, cartiers, graveurs, fondeurs de lettres*

⁷⁷⁷ Vervliet, *French Renaissance Printing Types: A Conspectus*, pp. 35-49. Vervliet restricts the typefaces he examined to those produced within ‘the borders of France during the major part of the sixteenth century’ and thus does not cover the Le Bé Hebrews produced in Venice.

<i>Punchcutter</i>	<i>Dates</i>	<i>Total Production</i>
Antoine Augereau	c. 1500 to 1534	4
François Gryphius	fl. 1531 to 1545	28
Claude Garamont	c. 1510 to 1561	34
Michel du Boys	c. 1510 to 1561	19
Jean Arnoul dit Picard	fl. 1539 to 1545	8
Pierre Haultin	c. 1510 to 1578	32
Robert Granjon	c. 1510 to 1590	±90
Guillaume I Le Bé	c. 1523/24 to 1598	18
Charles Chiffin	fl. 1545 to 1549	5
Nicholas II de Villiers	c. 1530 to 1613	10
Phillippe I Danfrie	c. 1531 to 1610	1
Julien Du Clos	fl. 1564 to 1584	4
Jacques I de Sanlecque	c. 1570 to 1648	9
Guillaume II Le Bé	c. 1570 to 1645	1

Fig. 5.1: Major sixteenth-century punchcutters according to Vervliet's *Conspectus*

The analysis of these major punchcutters shows that Le Bé was not the most prolific punchcutter of his age, certainly if one compares his output to that of Robert Granjon, for whom Vervliet makes a tentative attribution of nearly 90 typefaces.⁷⁷⁸ Le Bé was unusual in his concentration on Hebrew typefaces, but he was by no means the *only* punchcutter to have cut what are called ‘exotic’ typefaces, such as Hebrew, Arabic, Syriac or even Georgian.⁷⁷⁹ It is difficult to estimate from these figures if a particular punchcutter worked solely in this craft, and this seems improbable given the length of time required to cut, justify and cast a fount of type.⁷⁸⁰ If one assumes a production rate of roughly two founts per annum, then a total output of 28 typefaces over a working life of 14 years as in the case of François Gryphius is about correct. It is also true to say that most of the punchcutters active in the sixteenth century had more than one *métier*, as we have seen with Guillaume I Le Bé. Other examples are Robert Granjon was also a *libraire* and *imprimeur*, professions he may well have inherited from his father Jean Granjon, who was a *libraire juré* in Paris. Granjon is known for his frequent travels to Lyons, Antwerp, Frankfurt and finally Rome, thus confirming the pattern already discussed for Guillaume I Le Bé in his travels to Venice and Rome. Danfries was also a ‘graveur d’armoiries, graveur general des monnaies de France, cannonier ordinaire du Roi’. And finally Simones de Colines was a *libraire juré* as well as a noted *imprimeur*.⁷⁸¹

⁷⁷⁸ See *ibid.*, pp. 43-44

⁷⁷⁹ György Haiman and Elizabeth Soltész, *Nicholas Kis: a Hungarian punch-cutter and printer 1650-1702* (San Francisco: Jack W. Stauffacher, 1983), pp. 405-437

⁷⁸⁰ See page 120 of this thesis for more discussion on this point.

⁷⁸¹ Renouard, *Répertoire des imprimeurs parisiens, libraires, fondateurs de caractères et correcteurs d'imprimerie*, pp. 4-5, 181-183

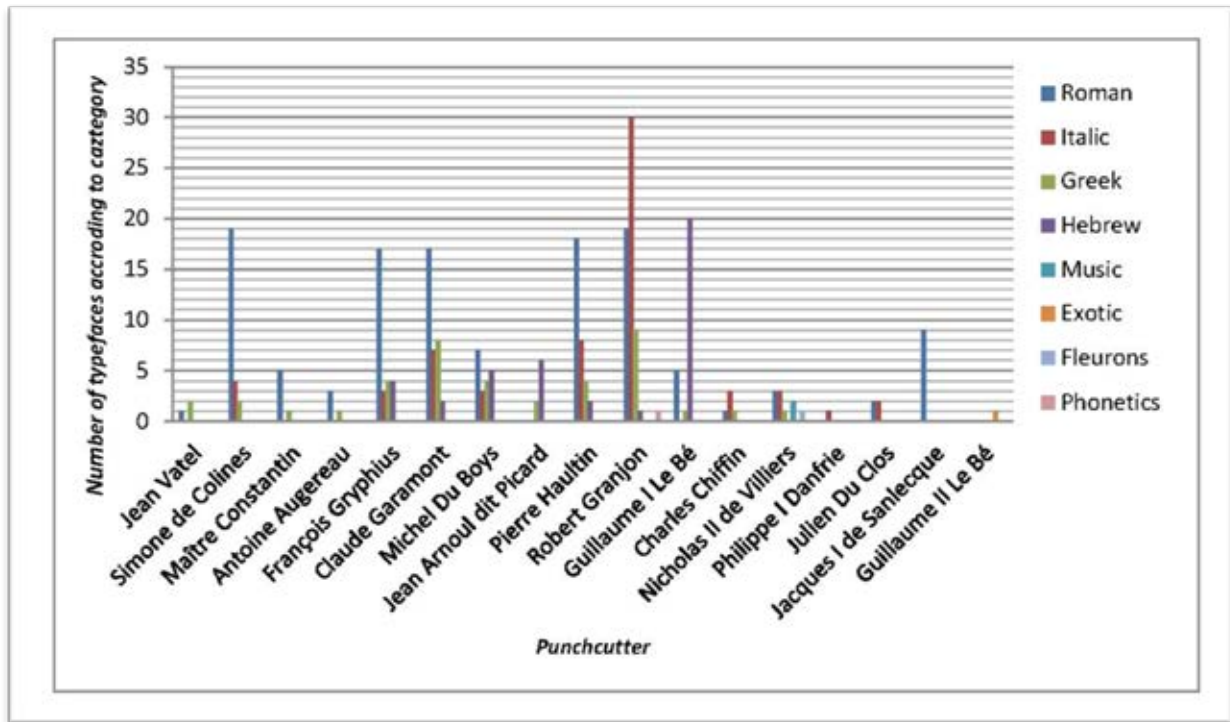

Fig. 5.2: Comparative output of sixteenth-century punchcutters based on Vervliet's *Conspectus*

Three further documents from the Minutier Central throw additional light on Guillaume I Le Bé's activities as a paper merchant. The first is dated the 18th of July 1551, and records that 'il prend en location un ouvroir repondant sur les rues Saint Jean de Beauvais et Saint Jean de Latran .. moyennant 50 lt par an'.⁷⁸² He is listed on this document as a 'papetier (marchand), Imprimeur et Libraire'. A document from the 10th November 1551 for an apprenticeship in which Le Bé appears as a witness, lists him only a 'libraire'.⁷⁸³ This can be compared to another document for Anselme Lebigot who was apprenticed to Claude Garamont (*sic*) on the 13th May 1551, in which Garamont is listed as a 'fondeur de Lettres, Paris'.⁷⁸⁴

The third document is dated the 26th of June 1560 and records that 'Guillaume Le be, le jeune, papetier, bourgeois de Paris, loue à son pere Guillaume le Bé, aîné, deux corps d'hotel et deux ouvroirs dans la maison ou il demeure au coin des rues Saint Jean de Beauvais et Saint Jean de Latran'.⁷⁸⁵ The wording 'prend en location un ouvroir' (rents a workshop) indicates that le Bé had rented these premises (which he later bought) for the purpose of either cutting types or storing paper. The second document speaks of him as renting two workshops to his father, and here one can assume that it was for the purpose of storing paper from the Le Bé paper mills in

⁷⁸² Minutier Central: ET/LXXIII/17

⁷⁸³ Minutier Central: ET/LXXIII/45

⁷⁸⁴ Minutier Central: ET/LXXIII/45

⁷⁸⁵ Minutier Central: ET/LXXIII/25

Troyes for sale in Paris. Annie Parent concludes that le Bé was ‘à la fois dépositaire du papier fabriqué à Troyes par son père, imprimeur et libraire’.⁷⁸⁶

It therefore appears very likely that Le Bé returned to Paris with the idea of establishing himself as an agent for his family’s paper mills in Troyes, at the same time continuing to cut type. His first type in Paris is dated ‘este (ete) 1551’ and Le Bé records that it was cut in Garamont’s house in the rue des Carmes. It is possible that Le Bé was mistaken in this date, and the date is more likely 1550, as we know that he was already established in the rue Saint Jean de Latran by this date. He did indeed continue to cut types after his return to Paris, but it is safe to say that he did not base his finances solely on his punch cutting nor supplying type to other printers. There may be confusion in the various entries between the old and new style calendars which would explain the difference in the dates.⁷⁸⁷

The evidence found to date is not conclusive enough to enable us to reach a definitive answer on the extent of his activities as a paper merchant during his lifetime. As previously mentioned, the *Inventaire après décès* of 1598 contains an inventory and appraisal of ‘toute la marchandise de pappier’ by Lois Rion, but this document has not survived and thus we cannot say with any certainty what stocks of paper were held by Le Bé on his death and where they might have come from. However, an inventory of the paper stocks would only have been undertaken if they had been sizeable and of commercial value to Le Bé’s heirs.

One might also expect that there would be have been a major amount of business between Le Bé and Christophe Plantin, yet there is only one mention of six reams of paper supplied by Le Bé to Plantin in March 1570 in a letter from Gilles Bey, Plantin’s son-in-law, then in Paris.⁷⁸⁸ Furthermore, in the period 1563 to 1567, Le Bé is not named as a supplier of paper whereas his kinsman Nicholas Le Bé *is* named, but he is listed only third in the list of French paper merchants from whom Plantin bought paper. Le Bé is mentioned for the period 1568 to 1576, but once again he is mentioned as seventh in a comparative listing. The amount of paper he supplied is just over 429 florins, which is quite small when compared to the amounts supplied by the Troyes paper merchant Jean Gouault, who is credited with supplying over 5,570 florins worth of paper. For the period 1586 to 1589 Jean Gouault is once again mentioned, but Guillaume Le Bé is not. It should be stressed that the lists compiled by Voet are from the extant Plantin ledgers, which are not complete. Voet notes that

⁷⁸⁶ Parent, *Les métiers du livre à Paris au XVIe siècle (1535-1560)*, p. 66. The first document cited is ET/LXXIII/17 and the second ET/LXXIII/25.

⁷⁸⁷ See definition of Old and new style calendars in the glossary.

⁷⁸⁸ Plantin, Denuce, and Rooses, *Correspondance de Christophe Plantin*, p. 132 (Vol. II). It has to be said that this is a small amount of paper, as it is a roughly the amount of paper required to feed one press per day. See Parent, *Les métiers du livre à Paris au XVIe siècle (1535-1560)*, pp. 56-57

'many deliveries of French papers seem not to have been recorded in the accounts either'.⁷⁸⁹

In the names of creditors mentioned in the 1598 *Inventaire après décès*, there are at least fourteen *imprimeur* and *imprimeurs libraires* mentioned who can be identified as being active in Paris in the period described by the various *ceddullles*, *brevets* or *sentence des juges* between the years 1587 and 1596.⁷⁹⁰ These notes are for monies still owing to Le Bé at the time of his death, and only one of them actually specifies what the expense was for: 'pour vente de fonte dimprimerie' and not for the supply for paper. Thus we do not have more detailed information for Le Bé's activities as a paper merchant for over 30 years: i.e. between the years 1550 and 1587. Yet one certain assumption is that Guillaume I Le Bé would have acted at least in part as an agent for his family's paper mills. There were seven paper merchants from the Le Bé family who were active during the period of Guillaume I Le Bé's lifetime and no doubt he would have patronised them out of family loyalty.⁷⁹¹

Inventories relating to the Le Bé Typefoundry

There are a series of inventories relating to the Le Bé Foundry, some of which have been found and examined, and others which once existed but have since disappeared.

It is important to examine the connection between these two documents – in particular NAF 4528 – and the surviving Le Bé foundry inventories. It can be assumed that any of the Hebrew types mentioned in the inventories would relate to the Le Bé Hebrews cut after his return to Paris, as he did not retain possession of those Hebrews punches or matrices which he had cut in Venice. This is confirmed by the attributions found for the earlier Venetian types and those for the later Parisian ones.⁷⁹² In addition the named punchcutters in the 1730 inventory are all French, which would indicate that the types in the Le Bé foundry were either cut or acquired in France, and not in Italy. Furthermore, the names (i.e. sizes) in the 1730 inventory differ from many of those in the two documents, and are evidence for a later listing when type sizes had become more standardised. Thus it does not seem likely that the two documents were ever used as a reference listing for the foundry during Le Bé's lifetime. They are not mentioned in the documents listed in the 1598 *Inventaire après décès*, but then they are not legal documents as such and contain no mention

⁷⁸⁹ Voet, *The Golden Compasses*, pp. 27-31. See also Christophe Plantin and Max Rooses, *Correspondance de Christophe Plantin, Uitgaven der Antwerpsche Bibliophilen ; nr. 12, 15, 26, 29-34*. (Nendeln, Liechtenstein: Kraus, 1968), pp. 189-190 (Vol. VI)

⁷⁹⁰ The names mentioned who are identified or known as printers and booksellers are: Jehan Richet (Jean I Richet), Denis Binet, Estienne Prevosteau, Pierre Fieffe, Pierre Luillier (Pierre Lhuillier), Leger Delas (Léger de Las or Delas), Michel Souyns (Michel I Sonnius ?), Arnoul Cottrier, Philippes Dupin, Jehan Corbon (Jean I Corbon or Corbom), Denis Duval, Mamert Patisson, Guillaume Anuray, and Adrian le Roy. See Renouard, *Répertoire des imprimeurs parisiens, libraires, fondateurs de caractères et correcteurs d'imprimerie* for cross references. See also Appendix F on p. 520.

⁷⁹¹ See p. 49 of this thesis.

⁷⁹² See discussion on page 363 and Appendix G on page 549.

of outstanding monies owed. They were still in the possession of the Fournier family in the eighteenth century, as we know that one of the documents was in the possession of Jean-Pierre Fournier l'aîné.⁷⁹³

The 1561 Garamont Inventory

This inventory was cited by Jean-Pierre Fournier (Fournier l'aîné), in his letter to the *Mercure de France* of May 1756 as proof that 'Plantin, après la mort de Garamond, acheta seulement des frappes et autres ustensiles de la fonderie dudit Garamond; mais ce fut Guillaume Le Bé qui en acheta les poinçons'. Fournier describes the document as 'l'inventaire, la prisée et la vente que Guillaume Le Bé et Jean le Sueur, autre fondeur de caractères, firent de la fonderie de Garamond après son décès, le 18 novembre 1561, à la Requête de Dame Isabeau Lefevre, veuve de feu sieur Claude Garamond, en son vivant, Graveur de lettres, & Maître Fondeur à Paris, & de sieur André Wechel, Marchand Libraire, Juré audit lieu, executeurs du Testament dudit défunt'. Fournier l'aîné claimed that he had the original of this document and maintained that it was 'Guillaume le Bé qui acheta les poinçons, & presque toute la fonderie de Garamond'.⁷⁹⁴ This document has never been found. It can be assumed that Fournier was referring at the least to the 18 sets of matrices and seven sets of punches attributed to Garamont in the 1730 inventory.⁷⁹⁵

Number	Size	Fount	Punchcutter	Number of matrices	Number of punches
1.	Gros Canon	Romain	Garamond	147	
2.	Petit Parangon	Romain	Garamond	161	
3.	Gros Romain	Romain	Garamond	207	
4.	Gros Romain	Italique	Garamond	216	
5.	Gros Romain	Italique	Garamond	146	
6.	Saint Augustin	Romain	Garamond	212	
7.	Cicero	Romain	Garamond A	205	
8.	Cicero	Romain	Garamond B	161	
9.	Cicero	Romain	Garamond C	220	
10.	Cicero	Romain	Garamont Premiere Taille	136	
11.	Cicero	Italique	Garamond	144	
12.	Cicero	Italique	Telle quelle Garamond	138 (cuime = cuivre)	
13.	Petit Romain	Romain	Garamond A	204	
14.	Petit Romain	Romain	Garamond B	157	
15.	Petit Romains (s. just)	??	Garamond	181	
16.	Petit texte	Romain	Garamond A	200	
17.	Petit texte	Romain	Garamond B	203	
18.	Petit Romain	Lettres 2 points	Garamond	23	
19.	Gros Canon	Romain	Garamond		140
20.	Gros Parangon	Romain	Garamond		148
21.	Gros Romain	Romain	Garamond		174
22.	Cicero	Romain	Garamond		225

⁷⁹³ Fournier and André, 'Lettres polémiques sur la typographie', p. 143. In his letter of January 1757 he cites Fr. Nouv. Acq. 4528 f. 9 on the sale of punches to Plantin 'à bon marché à cause des troubles'.

⁷⁹⁴ *Ibid.*, p. 94

⁷⁹⁵ Fournier and Morison, *L'Inventaire de la Fonderie Le Bé*. The inventory refers to various sets labelled Garamond A, B and C, as well as 'premiere taille'. The spelling follows the order and style of the inventory.

23.	Petit Romain	??	Garamond		196
24.	Gros Romain	Italique	Garamond		112
25.	Petit Romain	Lettres 2 points	Garamond		?

Fig. 5.3: Table of Garamont typefaces from the 1730 *Inventaire après décès*

The *Inventaire après décès* of 1598

The 1598 *Inventaire après décès* of Guillaume I Le Bé Mentions a ‘description et prisée par Jacques Duclos et Jacques de Sanlecque faite des matrices, moules, poinçons et autres ustancilles servans a la fonte de lettres dimprimeries, trouvés apres le decez dudit deffunct’. This inventory was not included in the main document at the express wishes of the executors of the will – Guillaume II Le Bé and Claude Andrenas – and was dated 20 July 1598. This document appears not to have survived.⁷⁹⁶ The ‘1730’ inventory may well be an accurate copy of the 1598 inventory.⁷⁹⁷

The Le Bé *Inventaire après décès* c. 1617

James Mosley mentions two documents associated with this date. The first may have run to more than 32 pages and ‘was clearly far more extensive than the document of 1730, of which it was presumably an edited summary’. The second was a ‘summary transcription of eight pages made from the inventory originally compiled by Guillaume II Le Bé in about 1617’. It is this copy that was included in the sale document of the Le Bé foundry to Jean-Pierre Fournier of 13 December 1730.⁷⁹⁸ This inventory was reproduced and described by Stanley Morison in 1957 in *l’Inventaire de la Fonderie Le Bé* and he maintained that it represented the state of the Le Bé foundry in c. 1598.⁷⁹⁹ The original is in the Archives nationales in the Minutier central des notaires.⁸⁰⁰ This document states specifically which types were cut by Guillaume I Le Bé and other punchcutters such as Haultin, Garamont, Granjon, Picard, Colines, and de Villiers. The total number of matrices listed is 120, of which 74 are roman or italic, 14 are Greek, 9 are Hebrew and 23 music. The total number of punches listed is 82, of which 30 are roman or italic, 4 are Greek, 6 are Hebrew and 11 are music. There is also heading for ‘poinçons et matrices séparées’, but most of these appear to be matrices. The inventory also lists 170 moulds. Each matrix or punch has a distinct sign which can be best described as almanac, planet or medical signs, but it is not clear what the purpose of these marks was. The Le Bé punches examined in Antwerp do not carry any such signs, so they were probably not a maker’s mark, but rather an identification sign used on each box or container.⁸⁰¹ In addition, each item has a number listed at the end (a total of 71), which are no doubt

⁷⁹⁶ Archives Nationales, Minutier Central, ET/LVX/161, p. 29

⁷⁹⁷ See page 142 of this thesis for further discussion.

⁷⁹⁸ Mosley, *Documents relating to the foundry of Guillaume Le Bé*, pp. 2-3

⁷⁹⁹ Fournier and Morison, *L’Inventaire de la Fonderie Le Bé*, p. 12

⁸⁰⁰ ET/LXV/229

⁸⁰¹ This material was stored in boxes (*boîtes*), as can be seen in the surviving probably later boxes in the Plantin Moretus. Some of the seventeenth-century punches in the Athias Cabinet in Amsterdam were stored in small circular medicinal containers, with the punches inserted into folded paper strips.

the numbers of the drawers in which the boxes were stored. The relevant parts relating to the Hebrew types are shown below.

	Name	Number of matrices	Box number	Probable equivalent typeface in the Le Bé Documents
1.	Hebreu Canon mon pere	37 m	32	HB14 (S)
2.	Hebreu Canon mon pere	90 m	33	HB14 (S)?
3.	Hebreu parangon encor (i.e. mon pere)	61 m	33	Hb13 (S)?
4.	Hebreu Gros Romain mon pere	95 m	33	Hb11 (S)
5.	Hebreu St Augustin mon pere	101 m	33	Hb19 (S)
6.	Glose Hebraique G. Romain mon pere	44 m	34	Hb22 (R)
7.	Glose Hebraique St Augustin mon pere	44 m	34	Hb18 (R)
8.	Glose Hebraique St Augustin encore de meme	44 m	34	Hb18 (R)
9.	Glose Hebraique Petit texte mon pere	35 m	35	Hb 16 (R)

	Name	Number of Punches	Box number	Probable equivalent typeface in the Le Bé Documents
1.	Hebreu Canon, mon pere	35 p	57	HB14 (S)
2.	Hebreu parangon mon pere	52 p	57	Hb13 (S)?
3.	Hebreu St Augustin mon pere	59 p	57	Hb19 (S)
4.	Glose Hebraique G. Romain mon pere	43 -p	57	Hb22 (R)
5.	Glose Hebraique St Augustin mon pere	42 p	58	Hb18 (R)
6.	Glose Hebraique Petit texte ou nomp. mon pere	n/a	58	Hb 16 (R)

Fig. 5.4: Table of Typefaces from c. 1617 Le Bé *Inventaire après décès* (AN ET/LXVI/229)

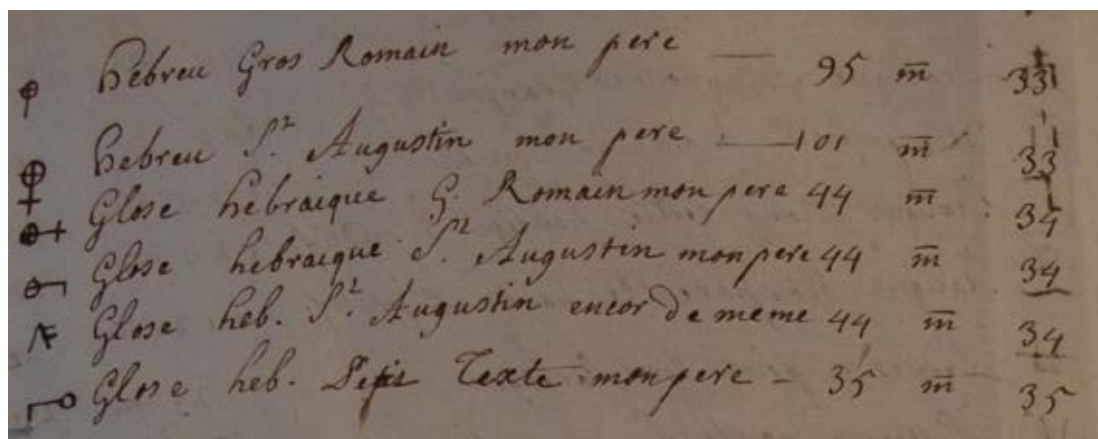
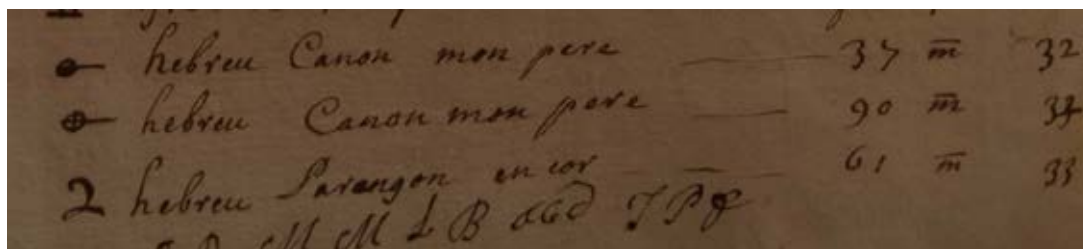

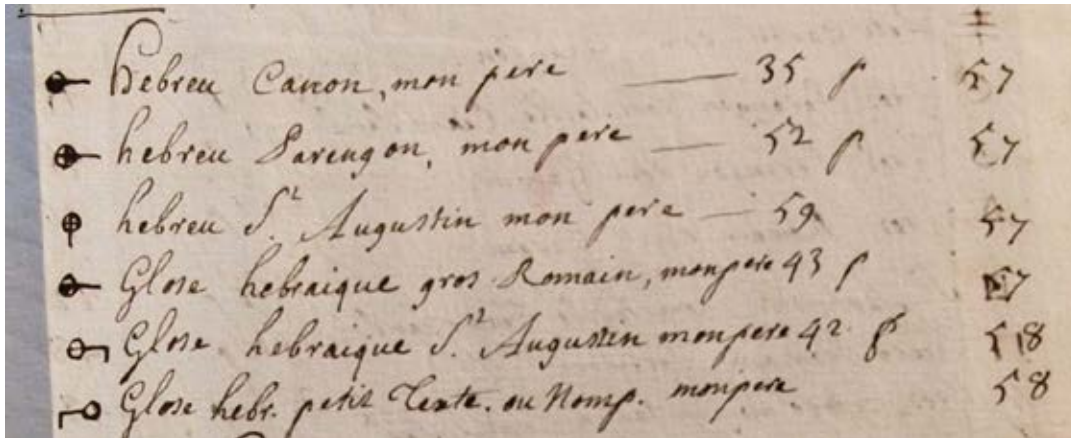

Fig. 5.5: Hebrew matrices and punches as listed in Archives nationales ET/LXVI/229

The Guillaume III Le Bé *Inventaire après décès* 1685

This document came to light after the publication of the 1617 inventory by Morison.⁸⁰² The estimation was carried out by Philippe Cottin ‘fondeur de Lettres Dimprimerie et Marchand Libraire A Paris’ and is held in the Archives nationales in Paris. Harry Carter studied it and produced a summary and transcription of the original document (OUP archives). This listing does not attribute types to specific punchcutters, except for the Guillaume II Le Bé Arabic, yet it does reproduce the signs (often *signes d’Almanachs et planettes*), which can be used to match similar the same typefaces in different inventories.

Name	Matrices or strikes	Number of Matrices or punches or strikes	Punchcutter according to Harry Carter	Probable Equivalent on 1617 inventory	Possible equivalent typefaces in the Le Bé documents
Hébreu Canon	Matrices Justifiées	37	Le Bé	Hebreu canon mon pere (37 or 90 matrices)	Hb14 (S)
Hébreu Parangon	Matrices Justifiées	80	Le Bé	Hebreu parangon encore (61 matrices)	Hb13 (S)?
Hébreu Parangon	Frappes	80	Le Bé?	Hebreu parangon encore (61 matrices)?	Hb13 (S)?
Hebreu rabbinis (sic) St Augustin	Frappes	44	Le Bé	Glose hebraique St Augustin de meme (44 matrices)	Hb18 (R)?
Hébreu de gros romain	Matrices partie Justifiées	106	Le Bé	Hebreu Gros Romain mon pere (106 matrices)	Hb11 (S)?
Hébreu Glose G. Rom.	Matrices Justifiées	47	Le Bé?	Glose Hebraique G. Romain mon pere (44 matrices)?	Hb22 (R)?
Hébreu Glose petit texte	Matrices Justifiées	35	Le Bé	Glose heb. Petit texte mon pere (35 matrices)	Hb 16 (R)?
Hébreu de St. Augustin	Matrices Justifiées	101	Le Bé	Hebreu St. Augustin de mon pere (101 matrices)	
Hébreu de St. Augustin	Matrices Justifiées excepté	92	Le Bé	Hebreu St. Augustin de mon pere (101 matrices)	

⁸⁰² 11 September 1685 (ET/LXX/182)

Name	Matrices or strikes	Number of Matrices or punches or strikes	Punchcutter according to Harry Carter	Probable Equivalent on 1617 inventory	Possible equivalent typefaces in the Le Bé documents
	dix matrices				
Hébreu sur le cicero	Matrices Justifiées	25	?	??	
Hébreu sur le cicero	Frappes non Justifiées	32	?	??	
Arabic LB sur le corps de Gros Parangon	Matrices Justifiées et non Justifiées	84	Le Bé II?	n/a	
Hébreu un petit de St Augustin	Poinsons	n/a	Le Bé	Hebreu St Augustin mon pere (59 punches)	
Hébreu de petit texte	Poinsons	n/a	Le Bé	??	
Hébreu et signes	Poinsons	n/a		??	

Fig. 5.6: Table of Hebrew and Arabic typefaces from Guillaume III Le Bé *Inventaire après décès* (11 September 1685 ET/LXX/182)

Lebreux

Item En une boîte marquée a costé hebreux Canon dans la quelle six bade
 En un an hebreux marqué \odot & costé parangon celui canon contient 24
 matrices justifiées Et le parangon contient 20 matrices aussy justifiées
 les deux frappes prises ensemble la somme de 20 ^{ll}

Item deux frappes dans une petite layette costé hebreu parangon, Et
 hebreu rabiny, St Augustin sans justifier marqué L lequel hebreu
 parangon contient 20 matrices Et celui de St Augustin contient 14 matrices
 les deux frappes prises ensemble la somme de 15 ^{ll}

Item une frappe hebreu de gros rom en une boîte marquée & contenant
 106 matrices partie justifiées Et l'autre qui ne est pas prise la somme de 10 ^{ll}

Item En une boîte costé hebreu globe g. rom Et globe petit sixte un marqué
 Et l'autre \rightarrow celui de gros rom contient 14 matrices justifiées Et
 de petit sixte En un paquet dans ladite boîte contenant 25 matrices
 justifiées tout pris ensemble dans ladite boîte la somme de 12 ^{ll}

Item En une boîte marquée \oplus Et il se trouve deux hebreu de St
 Augustin, un contenant 101 matrices justifiées Et l'autre 92 matrices
 justifiées excepté dix matrices qui ne sont pas justifiées tout
 pris ensemble la somme de 16 ^{ll}

Item deux frappes d'hebreux en paquets dans une petite layette costé
 deux frappes d'hebreu qui se font sur le cicero Et justifiées Et l'autre sans
 justifiées celui qui est justifiées contient 25 matrices Et l'autre qui ne
 est pas justifiées contient 32 matrices les deux prises ensemble la somme de 8 ^{ll}

Item une frappe arabe en une boîte costé arabe LB contenant
 84 matrices partie justifiées Et l'autre qui ne est pas sur le corps
 de gros parangon prise ensemble la somme de 15 ^{ll}

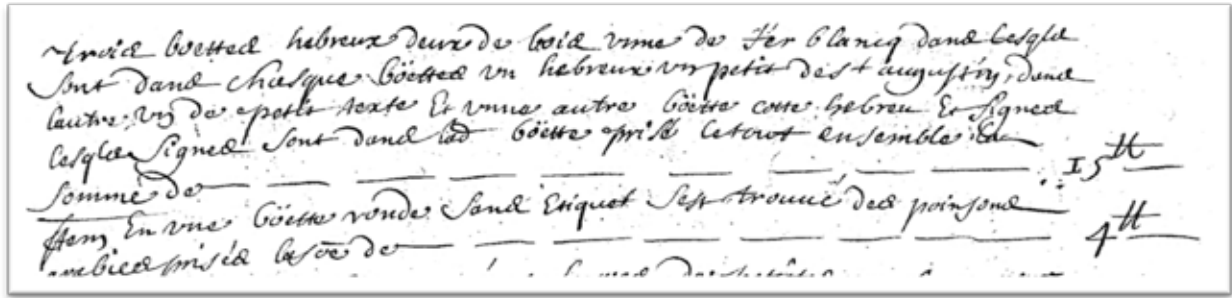

Fig. 5.7: Hebrew matrices and punches as listed in Archives nationales ET/LXX/182

The second Letter of Fournier l'aîné 1757

This final letter written by Fournier l'aîné to the *Mercure de France* of the 'Polemiques typographiques' series provides a partial listing of his foundry for purposes of self-advertisement. The relevant section reads as follows:⁸⁰³

De Garamond: Le Petite Texte, Petit Romain, Cicero, S. Augustin, Gros Romain, Petit Parangon & Gros Canon &c.

De Granjon Les italiques toutes ces corps: Un gros Cicero romain, Un petit Canon romain & italique, Mais surtout les caractères grecs de ce Graveur & d'autres, j'en ai depuis la Nompaille jusques & compris le Parangon. J'ai fourni le caractère grec de S. Augustin sur le corps de Texte & le grec de Petit Romain pour le Sophocles qui s'imprime actuellement.

De Guillaume Le Bé: la Grosse Nompaille, le Triple Canon, le Gros Canon gras, des notes de plain chant, rouge & noir, huit hébreux & rabbinique, & un arabe.

De plus il a conduit Jacques Sanlecque dans la gravure d'un Gros Parangon. De ce dernier, j'ai le beau S. Augustin, le Cicero moyen.

Je possède encore nombre de poinçons & matrice de différents Graveurs, comme Nompailles à gros œil & a petit œil, signes de toutes sortes &c, Caractère de Civilité, gothique sur tous les corps. J'ai gravé des notes de plain-chant, & grave tout ce qui m'est nécessaire en romain & italique. J'ai fait des moules à reglets de tous corps & grandeur, simples, doubles & triples, enfin on trouve dans ma fonderie tout ce dont on a besoin.

A further source of Le Bé's activities as a punchcutter comes from a series of letters published in a number of French learned journals from 1742 to 1759. The main protagonists in these letters appear to be the two Fournier brothers, Jean-Pierre Fournier (1706-1783) known as the elder (l'Aîné) and Pierre-Simon (also known as Simon Pierre) Fournier (1712-1768) known as the Younger (Le Jeune), both the sons of Jean-Claude Fournier (?? – 1729). It was Jean-Pierre Fournier l'Aîné who became the principal and later sole owner of the Le Bé foundry of which his father Jean-Claude Fournier had been manager to Guillaume III Le Bé. The 1730 inventory was

⁸⁰³ Lettre de M. Fournier l'aîné, Graveur & Fondateur de caractères d'Imprimerie, à Paris, rue S. Jean de Beauvais ; à l'auteur du *Mercure de France* Janvier 1757, pp. 85-95

part of the deed of sale of 20 December 1730 in which Jean-Pierre Fournier l'Aîné became the owner of the entirety of the former Le Bé foundry.⁸⁰⁴ His brother Pierre-Simon Fournier (le Jeune) is the author of the *Manuel Typographique* of 1764-1766.

The correspondence which sparked off this debate on the transmission and ownership of the Le Bé Hebrew types first appeared in the learned journal, the *Journal des Sçavans*, of February 1756 in which a second 'Lettre sur l'Imprimerie' by an 'auteur anonyme', and claimed that Garamont and Le Bé had supplied Christophe Plantin with the punches and matrices which with 'il a établi une fonderie celebre qui subsiste encore aujourd'hui'. The anonymous author of the letter was most probably Pierre-Simon Fournier le jeune.⁸⁰⁵

The riposte to this assertion was signed by Jean-Pierre Fournier l'Aîné and appeared in the *Mercure de France* of May 1756. The reply read in part as follows:

Il est vrai, Monsieur, que Plantin vint puiser à cette source; c'est-à-dire dans les fonderies de Claude Garamond et de Guillaume Garamond et le Bé lui ont fourni les poinçons et les frappes avec lesquelles il a établi une fonderie célèbre qui subsiste encore aujourd'hui.⁸⁰⁶ Ce sont les caractères Hébreux de ce dernier qui ont servi pour la Bible de 1569 dont l'impression fit tant d'honneur à Plantin dans le monde littéraire, et lui valut des récompenses honorables de la part de Philippe II, roi d'Espagne, par l'ordre duquel il l'avait entreprise. Le Bé, les beaux caractères dont il forma sa fonderie; *mais ni Garamond ni Le Bé ne lui fournirent point leurs poinçons, comme l'avance sans aucune preuve l'auteur de la lettre anonyme.* (my italics) Plantin, après la mort de Garamond, acheta seulement des frappes et autres ustensiles de la fonderie dudit Garamond; *mais ce fut Guillaume Le Bé qui en acheta les poinçons:* (my italics) ce qui se justifie par l'inventaire, la prisée et la vente que Guillaume Le Bé et Jean le Sueur, autre fondeur de caractères, firent de la fonderie de Garamond après son décès, le 18 novembre 1561, à la Requête de Dame Isabeau Lefevre, veuve de feu sieur Claude Garamond, en son vivant, Graveur de lettres, & Maître Fondeur à Paris, & de sieur André Wechel, Marchand Libraire, Juré audit lieu, executeurs du Testament dudit défunt. J'ai entre les mains cet inventaire en original, et l'on y voit que ce ne fut point Plantin, amis Guillaume Le Bé qui acheta les poinçons, et presque toute la fonderie de Garamond. *Le même Guillaume Le Bé vendit à Plantin des frappes de matrices de ses caractères hébreux, mais il en garda les poinçons:* (my italics) ce qui se justifie premièrement par l'inventaire de la fonderie de G. Le Bé, dressé par son fils, dans lequel inventaire on lit ces mots page 32, & en la même boîte (où est l'hébreu canon) est l'hébreu parangon: il est gras comme celui de la Bible in-4o de Robert Estienne: & celui-ci est celui de la

⁸⁰⁴ Archives Nationales, Paris ET/LXV/229. See also Allen Hutt, *Fournier, the compleat typographer* (London: Frederick Muller Ltd, 1972)

⁸⁰⁵ Fournier and André, 'Lettres polémiques sur la typographie', p. 41

⁸⁰⁶ See Fournier and Morison, *L'Inventaire de la Fonderie Le Bé*, p. 10. Morison confirms this point in his introduction.

grande Bible de Plantin, mon Pere lui en ayant vendu une frappe. La Bible de M. le Jay en est imprimée. Cette frappe-ci est garnie de points & d'accens..... Les poinçons sont céans. On voit par cet inventaire, *dont je suis possesseur*, que les poinçons des caractères hébreux qui servirent à imprimer la belle Bible de Plantin, ne furent point vendus à Plantin, *mais qu'ils passèrent au fils de Guillaume Le Bé, aussi-bien que presque tout.* (my italics)

How can one assess these two contradictory assertions, with the actual evidence that the Plantin Moretus Museum holds the following punches for the Le Bé Hebrew founts?

- ST 50: Hb12 (S) Le Bé's tenth dated 1559
- ST52: Petit texte Hebreu, probably recut by Le Bé, but does not appear in either of the BnF Documents.
- ST55: HB 15 (S) Le Bé's 15th dated 1569/70

ST50 was indeed sold by Le Bé to Plantin 'à bon marché à cause des troubles' as we know from Le Bé's annotation on NAF 4528 f. 9, and ST55 was also cut for Plantin in 1569 or 70, yet Le Bé obviously retained neither the punches nor the matrices, as he notes that 'je n'en ay peu recouvrer d'autre espreuve'. For ST52 we have evidence from the various MPM inventories that this Hebrew was 'retailé de Bé'. In addition to these sets of punches, there are also six sets of matrices of the Le Bé Hebrews in the MPM:

- MA6: HB12 (S) Le Bé's tenth dated 1559
- MA18: HB14 (S) Le Bé's 12th dated 1565/1566
- MA40: Hb13 (S) Le Bé's 11th dated 1565/1566
- MA83c: Vowels and cantillation marks possibly cut by Le Bé; to fit MA40
- MA72: Hb11 (S) Le Bé's 9th dated 1551
- MA82a: HB 15 (S) Le Bé's 15th dated 1569/70

What this list plainly shows is that Le Bé *did* sell punches as well as matrices to Plantin in Antwerp, but that he only sold the punches when he was in a difficult position financially or when he was directly commissioned to produce a type. If we look at the complete list of his transactions as set out in the annotations of the BnF Documents, the conclusion for his early period in Venice is that he had little control over the punches and matrices, and he did not bring them back with him on his return to Paris in c. 1550. He mentions several changes of location in Venice and this fact alone would not have allowed him to keep a large stock of punches or indeed matrices with him. It is likely that the material for the Hebrews, Greeks and Romans he cut in while in Venice would have remained with the printers themselves or have been sold on to other printers. The comment that he sold matrices to the Florentine

printer Lorenzo Torrentino and the Venetian printer Tommaso Giunta is a sign of his growing reputation and wider connections with the printing trade.⁸⁰⁷

<i>Where cut and date</i>	<i>No. of typeface in this thesis</i>	<i>Cut for</i>	<i>Strikes or matrices sold to</i>	<i>Le Bé Nos.</i>
Venice 1545-46	Hb1 (S)	Giustiniani		1
Venice 1546	Hb4 (S)	Giustiniani		2
Venice 1548	Rm 1			Le Bé for Christophe Zanetti
Venice 1546/47	Rm 2	??	Lorenzo Turentin in Florence and Tomaso Jontha in Venice	Le Bé and Jehan Arnoul
Venice 1547	Hb5 (R)	Meir di Parenzo	Matrices used without permission by Giustiniani? Resulting in Lawsuit	3
Venice 1547	Hb6 (S)	Meir di Parenzo and Carlo Querini		4
Venice 1547	Hb7 (R)	Meir di Parenzo and Carlo Querini		5
Venice 1547	Hb8 (R)	Meir di Parenzo		6
Venice 1548	Gk 1			Le Bé for Christophe Zanetti
Venice 1548	Gk 3			Le Bé for Christophe Zanetti
Venice 1549	Hb9 (S)	Meir di Parenzo	The punches and matrices sold to a German, from Dantzig?	7
Venice 1548/49	Hb10 (S)	Meir di Parenzo		8
Paris 1551	Hb11 (S)	Claude Garamont	The matrices and moulds bought by Plantin after the sale of Garamont's effects; The punches bought by Andre Wechel and taken to Germany LB bought a set of matrices from Wechel's widow	9
Paris 1555	Ms 1	Adrien Le Roy and Robert Ballard		
Paris 1555	Ms 2	Adrien Le Roy and Robert Ballard		
Paris 1559	Hb12 (S)	Le Bé	The punches, matrices and moulds sold to Plantin in 1562.	10
Paris 1559	Ms 5	Adrien Le Roy and Robert Ballard		
Paris 1566?	Hb13 (S)	Le Bé	Set of matrices sold to Plantin	11
Paris 1566	Hb14 (S)	Le Bé		12
Paris 1570	Hb 16 (R)	Le Bé	A set of matrices or strikes sent to Venice	13
Paris ??	Hb18 (R)	Le Bé	Set of matrices sold to Plantin	14
Paris	Hb 15 (S)	Plantin		15

⁸⁰⁷ Ascarelli and Menato, *La tipografia del '500 in Italia*, pp. 235-236, 328-329

Where cut and date	No. of typeface in this thesis	Cut for	Strikes or matrices sold to	Le Bé Nos.
1569/70				
Paris 1579	Hb18 (R)			16
Paris 1579?	Hb22 (R)	Le Bé for Carlo Querini in Venice		17
Paris 1573	Hb 17 (S)	Le Bé and Michiel Du Boys		18 (Unnumbered)
Paris 1591	Hb20 (R)	Le Bé		19 (Unnumbered)
Paris	Hb22 (R)	Le Bé		20 (Unnumbered)

Fig. 5.8: Table of Le Bé typefaces and their recipients

Once back in Paris and established in the rue Saint-Jean-de-Latran, Le Bé was able to begin to accumulate a stock of both punches and matrices. The purchase of the Garamont material in 1561 could well have been the crucial date in this regard. What then does the 1730 inventory tell us of the range of his typefoundry at the end of his life, as this inventory is generally taken to represent the inventory as it stood on the death of Guillaume I Le Bé in 1598.⁸⁰⁸ The inventory lists a total of 150 matrices and a surprising number of 170 moulds. These two figures are close enough to allow a working hypothesis that each separate set of matrices or size would have been supplied with its own mould during this period. If we then analyse the punchcutters listed by name for the matrices, 98 are by known punchcutters, whereas 52 are unattributed. The largest number of matrices are attributed to Robert Granjon (33), followed by Claude Garamont (20), Pierre Hautin or Haultin (16), Guillaume I Le Bé (11), Villiers (7), Simone de Colines (4), Philippe I Danfrie (2), with one each for Antoine Augereau, Hendrik van den Keere, Picard, Jean Micard and Jacques I de Sanlecque. In the section in the inventory on punches, 51 are listed in total, with 42 attributed to specific punchcutters and 9 unattributed. The largest number of punches are attributed to Sanlecques (13), followed by Le Bé (11), Granjon (9), Nicolas II de Villiers (8), Claude Garamont (7), with one each to Colines, Danfrie, Hautin and Jean Arnoul dit le Picard.⁸⁰⁹

An analysis of the type sizes offered by the Le Bé foundry shows a nearly a complete range of the most common text type sizes from Nompaille (Nonpareille) up to Grosse Nompaille, with Deux Points de Saint-Augustin, but only a range of four titling sizes. In addition there are 44 matrices for music (Nottes Plainchant, Grad. et Antiph, Tablature de luth et Guitarre) and five matrices for fleurons.⁸¹⁰ The list of

⁸⁰⁸ Fournier and Morison, *L'Inventaire de la Fonderie Le Bé*, p. 12

⁸⁰⁹ The inclusion of types by Jacques I de Sanlecques in this inventory is curious, as his assumed dates (c. 1570 to 1648) would place him towards the end of Le Bé's career. It is also been said that Sanlecques was apprenticed to Le Bé, and hence these types could be from his earliest period of activity as a punchcutter. Vervliet lists nine Romans possibly attributed to Sanlecque starting in 1583 to 1598. See Vervliet, *French Renaissance Printing Types: A Conspectus*, p. 47. See also Werdet, *Histoire du Livre en France depuis les temps les plus reculés jusqu'en 1789. Tom. 1-4*, p. 147 (Tome II)

⁸¹⁰ Antip. is a plainchant type for the large format of choirbooks and Grad. is a note intended for the *Graduale Romanum*, a liturgical book of the church containing chants. See Mary Kay Duggan, 'A

type sizes, based on Vervliet's comparative table of sizes is shown below.⁸¹¹ This is compared with the figures taken from David Shaw's analysis of four major styles of founts – Textura, Rotunda, Bastarda and Roman – which are taken from the index initially compiled by Col. Frank Isaacs of early printed books in the British Museum: from the invention of printing to the year MD. Shaw has identified what he calls clusters of common sizes. While the numbers are not by any means identical, they do point to similarities in commonly held founts sizes in sixteenth-century Parisian type foundries.⁸¹²

Type Size	Number of founts held in the Le Bé foundry	Overall number of Parisian type sizes (1501-1520) from the BMC VIII
Nompareille	4	43
Mignonne	6	47
Petit Texte	9	53
Petit Romain	13	64
Philosophie	2	75
Petit Cicero	1	
Cicero	16	81
Gros Cicero	2	
Saint Augustin	14	100
Gros texte		106
Gros Romain	11	114
Petit Parangon	1	
Parangon	1	
Gros Parangon	3	180
Petit Canon	1	225
Moyen Canon		240
Canon	2	
Gros Canon	3	
Double Canon	1	
Grosse Nompareille	1	
Gros Double Canon	1	
Lettres 2 pt. x petit texte	1	
Lettres 2 pt. x Gros Parangon	1	
Lettres 2 pt. x Petit Romain	3	
Lettres 2 pt. x Saint Augustin	1	
Total	98	1328

Fig. 5.9: Table of type sizes in the Le Bé typefoundry

This enumeration of the matrices and punches in the Le Bé typefoundry in the later years of the sixteenth century raises interesting questions as to the extent of Le Bé's activities as a punchcutter. The numbers of either punches or matrices attributed to Le Bé himself are quite small when compared to those from other punchcutters, such as Garamont and Granjon. This balance is confirmed by the attributions to named punchcutters in the MPM collections, which lists 11 types for Le Bé (all Hebrews), 20

System for Describing Fifteenth-Century Music Type', *Gutenberg-Jahrbuch* (1984), p. 71 and David Hiley, *Western plainchant: a handbook* (Oxford: Clarendon Press, 1993), p. 76ff

⁸¹¹ Vervliet, *French Renaissance Printing Types: A Conspectus*, pp. 52-53

⁸¹² David Shaw, 'Standardization of Type Sizes in France in the early Sixteenth Century', *The Library*, s6-111(4) (1981), p. 333

for Garamont, 49 for Granjon and 11 for Haultin.⁸¹³ This suggests that Le Bé had far less time to devote to punch cutting following his return to Paris, due to his increased involvement in managing the Paris branch of Le Bé family paper business. The tempo of types from the Venice years (eight in some five years) was not duplicated in the subsequent years in Paris, where he produced another 12 numbered types from 1551 to c. 1591 (a period of some 40 years).

Yet another question that needs to be asked is why Le Bé never issued a complete type specimen sheet during his lifetime, when he was the possessor of such a large selection of types? Guillaume II Le Bé did send a set of 11 separate specimens (including nine Hebrews) to Jan Moretus in Antwerp in 1598, following the death of his father. They contain handwritten annotations by Guillaume II, but are basically duplicates of the material in the two BnF documents and they could not be considered as a full specimen sheet.⁸¹⁴ As previously discussed, the idea of issuing such specimen sheets was not unknown in the sixteenth century. Plantin issued two type specimen sheets during his lifetime, the *Index sive specimen Characterum Christophori Plantini* of 1567 and the Folio Specimen of c. 1585 and later Konrad Berner issued his *Specimen Characterum seu Typorum Probatissimorum* in Frankfurt in 1592. The purpose of the 1567 specimen may have been to convince the Spanish Court that Plantin had the wherewithal to produce the Polyglot Bible. Plantin was not short of praise for the breadth of his collection, when he wrote that 'I do not think that elsewhere could be found in all Europe a collection to equal it for number, beauty and condition; and several of the printers and other good judges of the matter in France, Germany and Italy have written and confessed as much many times, and in my absence'.⁸¹⁵

If one can compare the 1592 Konrad Berner type specimen sheet to the earlier Plantin specimens, what is interesting is that Berner is setting out specimens of his types 'for the benefit of all those who use a pen, but principally for the particular advantage of authors of printer's copy, so that they may judge in what type their work may best be done; but equally useful to type-casters and printers as showing what may be of service in every printing-office and business'. He also writes that 'and you may have all manner of strikes, German, Latin, Greek and Hebrew, for hire or for sale, notwithstanding that all are at hand for casting'.⁸¹⁶ This differs in no way from the uses of modern type specimens. And what is striking as well is that they are being offered for sale or hire, so it can be said that the evolution to a fully formed typefoundry was complete by this date, at least in Germany.

This question touches in fact on one of the crucial questions of this thesis: Can we consider Guillaume I Le Bé to have been mainly a punchcutter or a type founder?

⁸¹³ Parker, Melis, and Vervliet, *Typographica Plantiniana II*, pp. 136-139

⁸¹⁴ MPM Arch. 153, f. 20 a through m. See also Lane, Vervliet, and Library, *Early type specimens in the Plantin-Moretus Museum*, pp. 239-250

⁸¹⁵ Dreyfus, *Type Specimen Facsimiles II Nos 16-18*, p. 1. See also Plantin, Denuce, and Rooses, *Correspondance de Christophe Plantin*, pp. 50-51 (Vol. I)

⁸¹⁶ Dreyfus *et al.*, *Type specimen facsimiles 1-15*, p. 3

The answer is that there is not enough documentary evidence to be able to point to a conclusive answer. John Lane has written on this point: 'Le Bé may have been one of the first typefounders in the modern sense, but the transition to supplying cast type instead of punches or matrices surely came gradually over the decades', and he added that 'evidence for local sales of cast type are less likely to survive, however, making it more difficult to document this evolution'.⁸¹⁷ This is indeed what we are seeing in the documentary evidence which has come to light so far. A thorough examination of the types used in the printed work of the printers and publishers named in the 1598 *Inventaire après décès* would probably determine whether any of the types from the Le Bé foundry were used or whether these contracts referred to the supply of paper only. Yet it seems clear to this researcher that Le Bé was able to offer no less a broad and useful selection of types than was boasted of by Plantin at the *Officina Plantiniana* in Antwerp. The absence of a formal type specimen sheet from the Le Bé foundry could well point to the conclusion that Guillaume I Le Bé and his successors had no need to issue such a specimen and that their reputation and contacts within the Paris printing world were enough to bring them in sufficient work and financial reward. On this point, Harry Carter's wrote that 'the punchcutters of the sixteenth century appear to have issued few collected specimens of their types, and hardly any survive. They dealt in matrices rather than in founts, and it was not until typefounders could offer printers a choice of cast type that the practice of issuing specimens became common'.⁸¹⁸

The conclusion of this researcher is that the Le Bé documents in the BnF were not intended to be used as type specimens for his clients, but rather as a personal record of the types cut by Guillaume I Le Bé or of other types which were of interest to him. Their 'personal' nature is emphasised by the fact that they contain mostly Hebrews and very little of the Roman, Italic and Greeks types mentioned in the inventories. Yet they do contain two unique type specimens: the Estienne Hebrews on Res X 1665, f. 4 and the possible Piove di Sacco specimen in Res X 1665 f. 22.

Analysis of the editions examined for this thesis

As discussed in Chapter 1, one of the major aspects of this research in this thesis was the examination of some 200 printed editions in various libraries, archives and repositories, either fully in Hebrew or with the occasional text in Hebrew. The object was to attempt to identify the use of the Hebrew types contained in the two BnF documents and from this analysis to formulate some hypotheses as to the spread of these types in the sixteenth century and beyond.

This examination is summarised in the following graph which shows the number of editions which contained one or more of the types in the Le Bé documents itemised by location. The major locations – Amsterdam, Basle, Leiden, Geneva, Paris and Venice - are indeed among the leading places for Hebrew printing in the sixteenth

⁸¹⁷ Lane, Vervliet, and Library, *Early type specimens in the Plantin-Moretus Museum*, pp. 239, 243

⁸¹⁸ See Delacolonge and Carter, *The type specimen of Delacolonge*, pp. 14-15..

and seventeenth centuries. It is useful to compare these findings to the data compiled by Stephen Burnett for the Christian Hebrew book market. For the period 1501 to 1560, he lists Paris, Basle, Venice and Lyons as the leading producers (from 21 to over 50 books), for the period 1561 to 1620, he finds Wittenberg, Paris, Geneva, Basle, Antwerp, Leiden, Lyons, Franeker, Leipzig, Nuremberg and Venice in this category, and finally for the period 1621 to 1660, this category includes London, Paris, Leiden, Amsterdam, Basel, Wittenberg and Leipzig. It should be noted that this compilation only includes 'Christian books containing a significant number of words and phrases in Hebrew type', and thus a different table might emerge if one took into account *only* books published in Hebrew for Jews, such as was used in Yeshayahu Vinograd's work.⁸¹⁹

The data prepared by Jean-François Gilmont for the sixteenth century is based on data from the *Index Aureliensis*. It also takes into account the nature of publishing in various parts of Europe, i.e. whether they were highly concentrated as in France, or more decentralised as in the Holy Roman Empire. Le Bé's main contacts during his lifetime were in France, Italy and the southern Netherlands, and the types he cut, being Sephardic, were less suited to the German-speaking lands, although some did get into these regions.⁸²⁰ Gilmont's data does not deal with Amsterdam, which only came into its own as a centre for Hebrew publishing in the early seventeenth century.

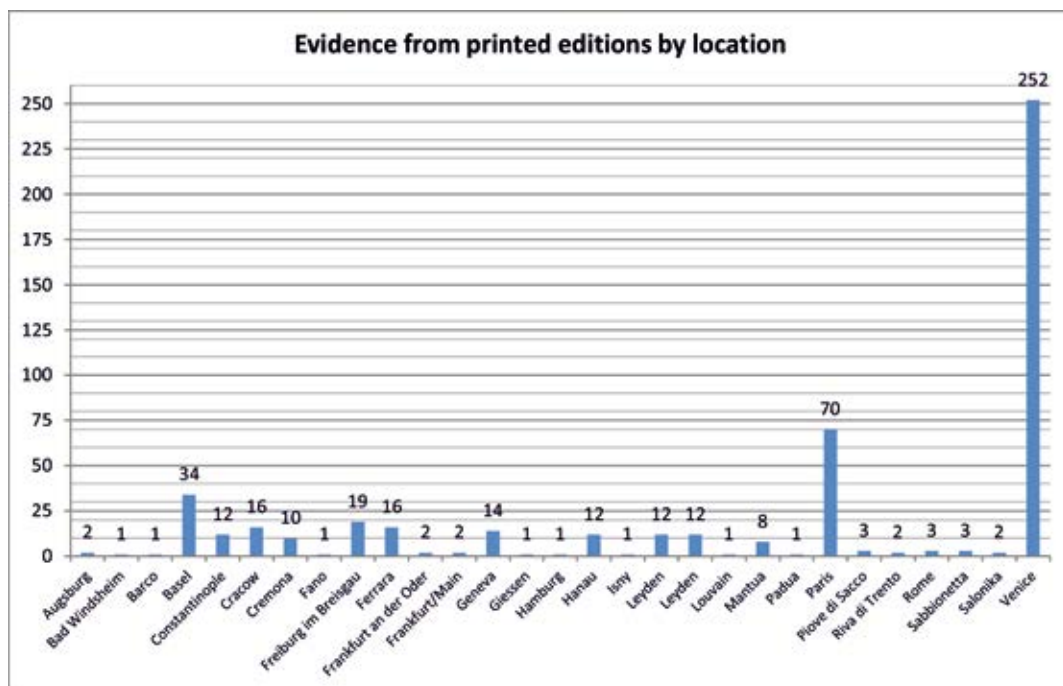

Fig. 5.10: Evidence from printed editions examined by location based on Jean-François Gilmont's data

⁸¹⁹ Stephen G. Burnett, *Christian Hebraism in the Reformation era (1500-1660): authors, books, and the transmission of Jewish learning*, *Library of the written word*, (Leiden: Brill, 2012), pp. 192, 199-200. See also Vinograd, *Otsar ha-sefer ha-Ivri*, *ibid*.

⁸²⁰ Jean-François Gilmont, 'Les Centres de la Production Imprimée', in *Produzione e commercio della carta e del libro secc. XIII-XVIII: atti della "Ventitreesima Settimana di studi" 15-20-aprile 1991 - Atti delle "settimane di studi" e altri convegni. Serie II ; 23.*, ed. by Istituto internazionale di storia economica F. Datini. Settimana di studi (23rd :1991: Prato Italy) and Simonetta Cavaciocchi (Firenze: Le Monnier, 1992)

<i>Region or country</i>	<i>Total number of editions 1501 to 1600</i>	<i>Main printing centres</i>	<i>Total Editions for main centres</i>	<i>Description of type of publishing centre</i>
German-speaking world	6744	9 (Cologne, Basel, Frankfurt am Main, Leipzig, Strasbourg, Wittenberg, Augsburg, Nuremberg, Tübingen)	6744	Totally unique situation: The nine main centres produced two thirds of the total output
Kingdom of France	6176	2 (Paris and Lyons)	6176 (90% of total production)	Model of high concentration
Italy	5849	5 (Venice, Rome, Florence, Milan, Bologna)	5849	Less radical type of concentration
The Netherlands Provinces and the Spanish Netherlands	1545	2 (Antwerp and Louvain)	1545	Less radical type of concentration
Iberian Peninsula	1050	N/a		Highly decentralised Large dispersal of printing offices
Great Britain	1016	1 (London)	1016	Model of high concentration
Central Europe	507	N/a		?
Switzerland Romande (Suisse Romande)	437	1 (Geneva)	437	Model of high concentration?
Outside Europe	31			?
Scandinavian Countries	25			?

Fig. 5.11: Publishing centres in the sixteenth century (from Jean-François Gilmont, 'Les Centres de la Production Imprimée', 1992)

The more comprehensive USTC (Universal Short Title Catalogue) presents a more up-to-date listing for the same period. The USTC accesses a much wider range of libraries, especially in France, but confirms in a more rigorous way the earlier findings of Gilmont. The Hebrew editions are probably an under estimation, as they appear to present mainly Christian Humanist editions, and not editions prepared solely in Hebrew for a Jewish audience, with the important exception of the Prostitz Cracow Hebrew editions.

<i>Region or country</i>	<i>Total number of editions 1501 to 1600</i>	<i>Main printing centres (in order of importance)</i>	<i>Total Editions for main centres</i>	<i>No. of Hebrew editions listed</i>
Balkans	208	10 (Bardejov, Trnava, Plavecký hrad, Bělá pod Bezdězem, Bratislava, Hlohovec, Nedelišče, Salonica, Hostie, Levoča)	106 for Bardejov	1
Bohemia and Moravia	1699	10 (Prague, Oloumouc, Litomyšl, Prostějov, Kralice, Plzeň, Mladá Boleslav, Ivančice, Mikulov, Náměšť nad Oslavou)	1260 for Prague	0
England	14,039	10 (London, Cambridge, Oxford, Sourthwark, Canterbury, Ipswich, Westminster, Worcester, Norwich,	13,288 for London and 204 for Cambridge	0

<i>Region or country</i>	<i>Total number of editions 1501 to 1600</i>	<i>Main printing centres (in order of importance)</i>	<i>Total Editions for main centres</i>	<i>No. of Hebrew editions listed</i>
		York)		
France	75,705	10 (Paris, Lyon, Rouen, Toulouse, Poitiers, Orléans, Tours, Troyes, Caen, La Rochelle)	44,290 for Paris and 21,116 for Lyon	47
Holy Roman Empire	94,192	10 (Wittenberg, Nuremberg, Cologne, Strasbourg, Leipzig, Frankfurt am Main, Augsburg, Erfurt, Magdeburg, Tübingen)	9406 for Wittenberg	93
Italian States	66,866	10 (Venice, Rome, Bologna, Florence, Milan, Naples, Brescia, Padova, Turin, Ferrara)	27,879 for Venice and 8859 for Rome	60
Low Countries	28,306	10 (Antwerp, Leiden, Louvain, Deventer, Amsterdam, Gent, Delft, Brussels, Douai, Den Haag)	13,524 for Antwerp	0
Poland	4183	10 (Cracow, Wrocław, Gdańsk, Poznań, Legnica, Toruń, Vilna, Brześć, Braniewo, Lwow)	2721 for Cracow	22
Portugal	1460	10 (Lisbon, Coimbra, Évora, Braga, Oporto, Goa, Viseu, Alcobaca, Almeirim, Faro)	925 for Lisbon and 385 for Coimbra	1
Scotland	367	3 (Edinburgh, St. Andrews, Stirling)	330 for Edinburgh	0
Spain	13,782	10 (Salamanca, Seville, Valencia, Alcalá de Henares, Madrid, Saragoza, Barcelona, Burgos, Toledo, Valladolid)	1999 for Salamanca	0
Swiss Federation	14,539	7 (Basle, Zürich, Bern, Fribourg, Geneva, Lausanne, Morgues)	7754 for Zürich and 3805 for Geneva	125

Fig. 5.12: Publishing centres in the sixteenth century (from the USTC database accessed 04/04/14)

The evidence from Chapter Two deals with Le Bé's types cut during his Venetian period from 1545 to 1550. The majority of attributions are, as might be expected, from Venetian printers, beginning with Le Bé's initial Venetian contacts Marco Antonio Giustiniani, Meir di Parenzo, and subsequently to other printers of Hebrew editions such as Giovanni di Gara, Alvise Bragadin, Giorgio di Cavalli, Giovanni Grypho and Cornelio Adelkind. There is no evidence that his types were used by Bomberg. In other Italian cities the Le Bé types were seen in Cremona (Vincenzo Conti), Ferrara (Samuel Usque), Mantua (Giacomo Rufinelli), Padua (Lorenzo Pasquati), Sabbioneta (Tobia Foa), and in Riva di Trento (Jacob Marcaria). Further afield, the Le Bé types were found in the editions of Konrad Waldkirch and Ambrosius Froben in Basel, Yitzhak ben Aharon Prostitz in Cracow, and in the

Hebrew editions of the Hanau Hebrew printers (Daniel Averi and Hans Jakob Henne). As previously noted, we know from Le Bé's annotations in NAF 4528 that Le Bé sold strikes of his Roman types to Lorenzo Torentino in Florence and to Tomaso Giunta in Venice, as well as Greeks to Christophoro Zanetti in Venice. This provides evidence in itself that Le Bé had wide ranging business contacts with printers, but did not necessarily record many of these transactions during his early period in Venice.

The evidence from Chapter three covers Le Bé's types cut after his return from Venice. The majority of the attributions are from Parisian printers, such as Guillaume Morel, Pierre l'Huillier, Jean Bienné, with later uses in the seventeenth century by Pierre Variquet, Jean Laqueray, Guillaume II Le Bé and Antoine Vitré (for the Paris Polyglot Bible of 1645). In addition there are the recorded uses by the *Officina Plantiniana* in Antwerp, and in Leiden by Franciscus Raphelengius and Johannes Le Maire. There are also some possible uses in Venice by di Gara and di Cavalli, with a more certain attribution to Zifroni's 1620 *Hagadah shel Pesach* printed in Venice in 1609. Lyse Schwarzfuchs has written that 'il est possible que la majorité des fontes utilisées à Paris aient été gravées d'abord par Jean Arnoul et puis par Guillaume Ier Le Bé', yet the data from the volumes examined seems to indicate that Le Bé had a lesser market for his own Hebrew types in the period following his return to Paris. He was no doubt concentrating more on his activities as paper merchant, or possibly began to sell types obtained from the sale of the Garamont foundry in 1651. There also appears to have been a decline in the number of both Hebrew and Aramaic grammars, and Hebrew Bibles printed in Paris from the mid-sixteenth century to the end of the century.⁸²¹ This may reflect the adverse cultural and economic conditions brought about by the various Wars of Religion, which began in 1562 and only ended in 1598 with the Edict of Nantes.⁸²²

Chapter four contains the analysis of the types from document Rés X 1665. The type specimens here are inserted in a non-chronological order and all are Hebrews, with seven repeats from NAF 4528. In this document, Le Bé has provided a wide selection of Hebrew typefaces cut by both identified and unidentified punchcutters. The range of dispersion of these types is thus quite wide, from Amsterdam, Antwerp, Leiden and Louvain in the northern and southern Netherlands, Frankfurt/Main, Frankfurt an der Oder, Giessen, Isny, and Hanau in the German speaking lands, Basle and Geneva in Switzerland, Cracow in Poland, Constantinople and Salonika in the Ottoman Empire, Paris in the Kingdom of France, and finally ten cities in Italy with the most occurrences as is to be expected in Venice.

It is useful to compare with these results with Yehoshua Vinograd's *Thesaurus of the Hebrew Book*, which is a major source for Hebrew editions in the sixteenth century. Vinograd's listing is limited to editions printed *entirely* in Hebrew, yet nonetheless the Vinograd data clearly demonstrates the predominance of Venice as a Hebrew publishing centre. A summary of the data presented by Vinograd for the sixteenth

⁸²¹ Schwarzfuchs and Coron, *Le livre hébreu à Paris au XVIe siècle*, pp. 52-54

⁸²² Wood, 'The Impact of the Wars of Religion: A View of France in 1581', p. 167

century illustrates the clear dominance of Italy. Several figures are worth noting: the almost total lack of Hebrew editions from Spain and Portugal, which illustrates the results of the expulsions from the previous century, and the relatively small number of editions from northern Europe during this period (Antwerp, Leiden and Amsterdam).⁸²³

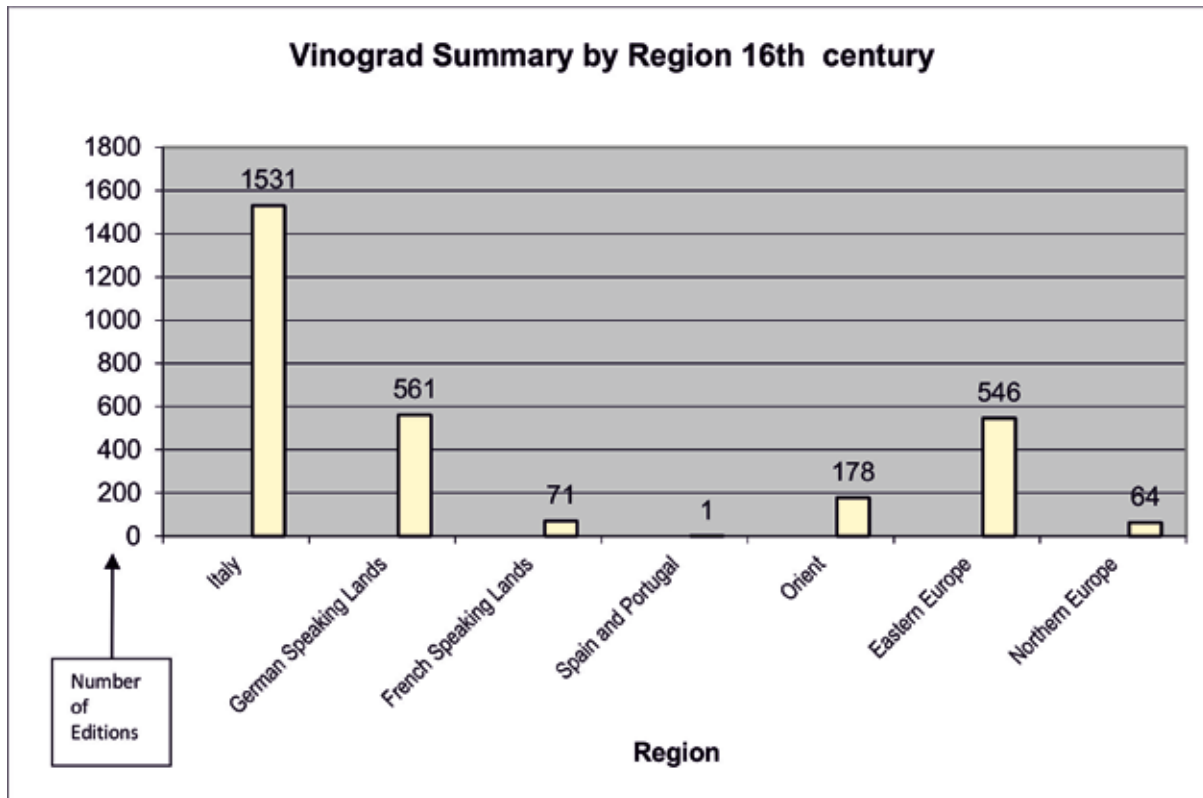

Fig. 5.13: Vinograd Summary by Region for the Sixteenth century

One of the interesting but not unexpected results from the attributions is the wide distribution of the Bomberg types, especially in Venetian editions, but also in Antwerp where they came into the *Officina Plantiniana* following Bomberg's return from Venice. Other types, such as HB24 (S), which Le Bé attributes to a 'Jacob de Mantoue' was found in over 40 examined editions from Cracow, Constantinople, Salonika, Mantua and of course in Venice, and one can only assume from such a wide distribution that multiple strikes were made from the original punches. One such set is to be found in the Museum Plantin Moretus in Antwerp (MA34). The sale or transfer of matrices is attested by a document dated 17 August 1559 found in the Archivio di Stato concerning the printers Meir di Parenzo and Abram Usque, which deals with 'quattro sorte de madre de lettere'.⁸²⁴

The full details of the evidence from the examined editions can be found in tabular form in Appendix G, on p.578.

⁸²³ Vinograd, *Otsar ha-sefer ha-Ivri*

⁸²⁴ Archivio di Stato, Venezia Notarile Busta 8246

Dispersals of the Le Bé Hebrew Types: Wechel, Zifroni, Prostitz and others

Several of the Le Bé types – for example Hb6 (S), Hb 10(S), and Hb11(S) – were found to have been used in Basle editions printed by Ambrosius Froben and Konrad Waldkirch during the period 1578 to 1583. The link to Le Bé here is via the Italian Jewish printer Daniel Zifroni (Sifroni). It is worth recounting something of his background.

Zifroni came from the town of Guastalla in Emilia Romagna according to his self-description on the imprint of his first imprint in Freiburg in 1583. It is thought that in his early years he worked for the printer Vincenzo Conti in Cremona, before moving to Basle to work for Ambrosius Froben.⁸²⁵ Conti was active in the publication of Hebrew works between the period 1556 to 1586 and five of the Le Bé types – HB2 (R), Hb5 (R), Hb6 (S), Hb 7 (R) and Hb10 (S) – were found in his editions.⁸²⁶ It is also known that following his period in Basle and Freiburg, Zifroni returned to Italy where he printed in Venice from 1588. He is known for a now rare edition of the Passover Haggadah from 1609.⁸²⁷ Zifroni was known as Israel ben Daniel, but there is also a mention of a 'Mosè ben Israel Elisciana Siforni', who from his dates and places of activity, appears to be the same person.⁸²⁸ It appears that that Zifroni was skilled in type casting as well as printing, and that he obtained several of the Le Bé matrices which he took with him to Basle.

Ambrosius Froben (1537-1602) was the grandson of the noted Basle printer Johannes Froben (Frobenius). In 1578 Froben applied for and received permission from the City of Basle to engage a Jewish master printer to supervise the printing of the expurgated version of the Babylonian Talmud, financed by the Frankfurt businessman and scholar Simon Günzberg. Post and Schumacher note that Zifroni brought the necessary Hebrew printing types with him from Italy and that possibly a new type for the Talmud edition was specially cast. They also note that Froben had in his press some nine Hebrew types: Hebrew, Aramaic and Yiddish, and that these types were passed on to Konrad Waldkirch after the period of printing in Freiburg was over.⁸²⁹ It is also known that Zifroni was accompanied by Jacob ben Isaac Luzzato, a scholar and author of various works, including the explanatory notes to

⁸²⁵ Post and Schumacher, '*Die Jüdische Drucker Israel Sifroni in Freiburg i. Br.*', p. 65

⁸²⁶ Giovanni Bernardo De Rossi, *Annali Ebreo-tipografici di Cremona* (Parma: Stamperia Imperiale, 1808)

⁸²⁷ Narkiss and Modena, *Seder Hagadah shel Pesach, Venetsyah 369 = The Passover Haggadah, Venice 1609*

⁸²⁸ Ascarelli and Menato, *La tipografia del '500 in Italia*, pp. 186, 442. He appears to have been active in Mantua in 1593.

⁸²⁹ Post and Schumacher, '*Die Jüdische Drucker Israel Sifroni in Freiburg i. Br.*', p. 66. The original text reads as follows: 'Die benötigten hebräischen Drucktypen brachte Sifroni zum größten Teil aus Italien mit, möglicherweise wurde speziell für den Talmuddruck eine zusätzliche Type neu gegossen. Insgesamt wurden in Frobens Offizn neun Drucktypen für hebräische-schriftliche (hebräische, aramäische und jiddische) Texte verwendet, die nach dem Freiburger Intermezzo von Froben und Sifroni an den Basler Drucker Konrad Waldkirch weitergegeben wurden'.

the Basle expurgated Talmud. Luzzato called himself a 'corrector', thus his role in Froben's press was probably that of proofing and correcting text.⁸³⁰ In 1583 Froben moved to Freiburg (in present-day) Germany where he printed some seven Hebrew editions during the next two years. Zifroni accompanied him to Freiburg, as Froben had to seek permission for Zifroni and his wife Bilha to dwell in the town.⁸³¹

If Zifroni's Hebrew type which he used in Basle and Freiburg was later transferred to Waldkirch on his departure, then it is likely that he had matrices with which he was able to cast fresh type for his 1609 *Hagadah* in Venice. Waldkirch used the Le Bé Hebrews in at least two editions of the writings of the English Hebraist Hugh Broughton which he printed in the late 1590s.⁸³² This may well be the pattern for many of the Le Bé type dispersions seen in this thesis.

Another possible link to Le Bé is through the press of André Wechel. Wechel was the son of Chrétien Wechel and was active in Paris from about 1535 until 1572, when he was forced to flee following the events of the St Bartholomew's Day Massacre. Wechel was clearly capable of striking matrices from punches, as is evidenced by the ban placed on him from casting the Garamont Grec du Roy in March 1562.⁸³³ He re-established his press in Frankfurt am Main and died in 1581.⁸³⁴ Wechel was clearly on close terms with Le Bé, and Le Bé notes in an annotation that Wechel had the punches for Hb11 (S) which he took with him to Frankfurt. An examination of the editions printed by Wechel in Frankfurt has not yet shown any use of this typeface, however Wechel did appear to have a set of Hb51 (A) which he used.⁸³⁵ The trail of Le Bé's Hebrews to Germany via Wechel and his heirs is still unclear, yet what information we do have points to a transferral or sale at some point.

Yet another link to the spread of Le Bé's Hebrews further afield in Poland comes from the Jewish printer Itzhak ben Aharon Prostitz. Prostitz came from a family of Italian Jews settled in the Moravian town of Prostitz (Prostějov) and was sent as young man to Venice to learn the trade of printing. There he worked for Giorgio di Cavalli and Giovanni Griffio (Griffo), and it has been variously claimed that Prostitz

⁸³⁰ Heller, 'Ambrosius Froben, Israel Zifroni and Hebrew Printing in Freiburg im Breisgau', p. 3. See also 'Luzzato' (<<http://www.jewishencyclopedia.com/articles/10203-luzzatto-luzzatti>> [Accessed 6 November 2013])

⁸³¹ Post and Schumacher, 'Die Jüdische Drucker Israel Sifroni in Freiburg i. Br.', p. 67

⁸³² For example: Hugh Broughton, *An epistle of an ebrew willinge to learne Christianity sent by him to London: & thence, by the Archb. of Canterburies aduise, to Basil: thence returned vwith [sic] some further spech vpon it vnto the Quene of Englandes most excellent maiesty* (Basel: Connadus VValdkirch, 1598) and Hugh Broughton, *Epistolae variae et variarum linguarum, de Byzantiacis hebraeis, discupientibus erudiri in Christi D. Sacro volumine, atque adeo de alio magno viro, quem nisi obliquè significare, Byzantij saltem non oportet, in re adhuc dubiâ. Argumennum docebit susius sequens pagina* (Basileae apud Conradum Waldkirch, 1599)

⁸³³ Lepreux, *Gallia typographica*, p. 417. The edict apparently was to prevent the damage to the punches by 'gens inexpetz qui ne se pouvoit faire sans les rompre, chose irréparable et dommageable au public'.

⁸³⁴ Lefanu, 'André Wechel', . See also the article on Chrétien and André Wechel in Pierre Bayle and Prosper Marchand, *Dictionnaire historique et critique* (Amsterdam, Leiden, 1730), pp. 490-491 (Tome IV)

⁸³⁵ See page 337 for discussion.

bought di Cavalli or Grypho's printing material (including his types) in 1568 when their presses were closed.⁸³⁶ Prostitz then moved back to Poland and established his press in Cracow in 1568 or 1569, where he was active until 1602. He was accompanied by Samuel ben Itzhak Boehm who had worked with Grypho as a proof reader. As Giorgio di Cavalli was still printing Hebrew texts in 1585 and Grypho's five Hebrew all date from the period 1566 to 1567, it seems more likely that Prostitz got his types from Grypho's press sometime in 1567, although no documentary evidence has been produced to support this claim.⁸³⁷ Grypho witnessed an amendment to the *Mariegole* (bye-laws) of the Venetian Guild of Printers and Booksellers in September 1571, so one may assume that he was still active at this date.⁸³⁸ Whatever the truth of this matter, at least four of Le Bé's Venetian Hebrews – HB2 (R), Hb6 (S), Hb7 (R) and Hb10 (S) – and two from other punchcutters – Hb24 (S) and Hb38 (S) – were found in the Prostitz Cracow editions and the assumption must be that these types were acquired by Prostitz at some period before his return to Poland.

A possible and as yet unconfirmed link to Le Bé is to the London printer Henry Bynneman, who was active in several locations near St Paul's Cathedral from about 1563 to his death in 1583. On his death a writ was issued listing all his possessions, as he owed £1000 to one Richard Hutton, an armourer. The articles of interest to this thesis are from the following lines in the inventory:⁸³⁹

- 18. Item one litle old hebrue alphabett ij^d (2d)
- 20. Item one older Richechling dictionarie hebrue ijs iiij^d (2/4d)
- 21. Item one older hebrue case farnished, wayeng thirtie pounds and one old case with Greeke in it wayeng thescore pounds xxxvij^s vj^d (37/6s)
- 45. Item one small case of hebrue and one case of hebrue poyntes wayenge fourteen pound net xiiij^s (14/-)
- 46. Item one hebrue mattriz iij^{li} (£3)
- 47. Item one mattris variorum vj^s viij^d (6/8d)
- 48. Item one double greke matts x^s (10/-)
- 49. Item one mattris of the olde hebrue romaine, one mattris of the pica Roman itallica and one other of diuerse sortes iiij^{li} (£4)

⁸³⁶ Friedberg, *Toldot ha-defus ha-Ivri be-Polanyah: me-reshit hivasdo bi-shenat 294 ve-hitpathauto ve ad zemanenu (History of Hebrew Typography in Poland)*, p. 5 and Krzysztof Pilarczyk, *Leksykon drukarzy ksiąg hebrajskich w Polsce: z bibliografią polono-judaików w językach żydowskich (XVI-XVIII wiek)* (Kraków: Wydawn. Antykwa, 2004), p. 70

⁸³⁷ British Museum Dept. of Printed Books, Johnson, and Scholderer, *Short-title catalogue of books printed in Italy and of Italian books printed in other countries from 1465 to 1600 now in the British museum*, pp. 806, 856

⁸³⁸ Brown, *The Venetian Printing Press*, pp. 82, 87, 251-252

⁸³⁹ P.S. Handover, *Printing in London, from 1476 to modern times. Competitive practice and technical invention in the trade of book and Bible printing, periodical production, jobbing, &c. [With facsimiles.]* (London: George Allen & Unwin, 1960), p. 30

- 55. Item one alphabet of Greke lettres iij^s iiij^d (3/4d)
- 57. Item seventeen seuerall sortes of moulds for seuerall sortes of lettres vj^s viij^d (6/8d)

The 'hebrue' and 'Greke' alphabets (items 18 and 55) are no doubt printed *alphabetum* of the sort produced by Robert Estienne and Plantin.⁸⁴⁰ The disparity in prices could be explained by condition, extent or rarity of the edition. The 'Richechling dictionarie hebrue' (item 20) must be Johannes Reuchlin's Rudiments of Hebrew [*Principium libri Ioannis Reuchlin ... de rudimentis hebraicis*], printed in Pforzheim in 1506 by Thomas Anshelm. All this material was probably meant to serve as a source or base for a projected Hebrew dictionary, which never materialised. What is of major interest are the set of matrices for an unknown Hebrew, valued quite high at £3, as compared to the Greek matrices which were valued at a sixth of the Hebrews. Bynneman also had seventeen moulds, which are far in excess of the total number of cases of type listed in the inventory, but one may assume that they related to specific sizes in the printed editions of Binneman's stock. The inventory lists some 1082 books owned by him 'at a shop in St Gregory's by St. Paul's'.⁸⁴¹ This item also tells us that many London printers of this period needed to cast their own type or indeed import from abroad, given the lack of evidence for any native English type foundries until at least 1597. Baines Reed notes that 'type was one of the latest of the printer's commodities to go into the public market' and that it was not until printing of Walton's Polyglot Bible in 1657 that the 'first important (Hebrew) fount was cut in this country'.⁸⁴² A further confirmation of this assertion comes from Harry Carter. He wrote that 'there is every sign that the mechanical part of English type founding was in the hands of resident aliens and that a demand for better designs was satisfied by imports or migrations of skilled men'.⁸⁴³

There are no known Hebrew editions printed by Bynneman and 'the lack of Hebrew type in England' in the sixteenth century has been noted by both Lloyd-Jones and Schper.⁸⁴⁴ Thus the most obvious source for these Hebrew matrices would have been either the Low Countries or France. One possible clue is found in Bynneman's 1579 edition of the *Profitable Art of Gardening*, in which he uses an Arabesque border which came from Plantin in 1567, and which was in fact in Binneman's stock of

⁸⁴⁰ See Appendix I on p. 563.

⁸⁴¹ This church stood at the south-west angle of St Paul's Cathedral and was destroyed during the Fire of London. It was not rebuilt. See James White, *The churches & chapels of old London: with a short account of those who have ministered in them* (London: Printed for private circulation, 1901), pp. 50-57

⁸⁴² Reed and Johnson, *History of the old English Letter Foundries*, pp. 55-57, 114, 118

⁸⁴³ Edward Rowe Mores *et al.*, *A dissertation upon English typographical founders and founderies (1778): with A catalogue and specimen of the typefoundry of John James (1782)*, Oxford Bibliographical Society publications. New series ; v.9 (Oxford: Oxford University Press, 1961), p. lxx. See also Frank Isaac, *English Printers' Types of the Sixteenth Century* (Oxford and London: Oxford University Press and Humphrey Milford, 1936), pp. 35-46, who confirms this point.

⁸⁴⁴ See Lloyd Jones, *The Discovery of Hebrew in Tudor England: a third Language*, p. 183 and Schper, 'Christian Hebraists in Sixteenth Century England', pp. 22, 278, 284, 286

borders.⁸⁴⁵ A further clue is item 45, a 'small' setting fount of pointed Hebrew, which could well have been Le Bé's HB 11 (S) dated 1551 or HB18(S) dated 1579. It is more than likely that the conduit for these Hebrews would have been the Flemish-born printer Reyner (Reginald) Wolfe, who had settled in London in about 1533 and had numerous continental contacts. In 1547 he became the King's printer for Latin, Greek and Hebrew. It is known that Binneman acquired printing material from Wolfe after his death in 1573.⁸⁴⁶ This remains for the present no more than a plausible hypothesis, until a specimen of one or more of Bynneman's Hebrews can be found.

The Influence of the Le Bé types

The final topic to be discussed in this summation chapter is the impact of Le Bé's types on the Hebrews of succeeding generations. Stanley Morison's assessment of Le Bé's Hebrew has already been cited in Chapter One, and Harry Carter was equally enthusiastic in his praise ('What magnificent letters!').⁸⁴⁷ Earlier assessments of Le Bé were also fulsome, such as that of Pierre-Simon Fournier le jeune in 1756, who wrote that 'Guillaume le Bé, disciple de Robert Etienne, perfectionna le caractère hébreu: pendant 4 ans ou environ qu'il fut dans cette ville, il l'enrichit de huit ou dix sortes de caractères tant hébreux que rabbiniques, tous parfaitement beaux, dont le Talmud et d'autres grands ouvrages ont été le fruit'.⁸⁴⁸

The examination of a sample number of printed editions from the sixteenth and seventeenth centuries shows wide distribution and use of the Le Bé Hebrews, with a concentration in either Venice or Paris, places where he was active and worked. The examination also showed extensive uses in Basel, Cracow, Antwerp and Leiden, places where there is evidence of a secondary transmission or actual commissions to Le Bé. There is little evidence for the use of the Le Bé Hebrews in the German-speaking world, which would have been greater had Le Bé actually cut any Ashkenazic Hebrews during his career. Le Bé showed only one page of Ashkenazic Hebrews in Res X 1665, a sign that he was not greatly interested in them or perhaps that he did not see much of a potential market for such Hebrews.

The influence of Le Bé can be seen in the northern Netherlands, which became the dominant centre of Hebrew printing in the seventeenth century. In 1627 in Amsterdam, the rabbi, author, and printer Menasseh ben Israel printed his first Hebrew edition, the *Seder Tefilot*, a daily prayer book according to the Sephardic rite. His proof reader, Isaac Aboab da Fonseca, wrote in the introduction to this work that:

⁸⁴⁵ Meynell and Morison, 'Fleuron anthology', in *Fleuron anthology. Chosen and with a retrospectus by Francis Meynell and Herbert Simon*, ed. by Meynell and Simon (Tonbridge, Kent and London, Toronto and Buffalo: Ernest Benn and University of Toronto Press, 1973), p. 29. See Handover, *Printing in London, from 1476 to modern time*, p. 28 for a facsimile of this title page.

⁸⁴⁶ See the entries for Henry Bynneman and Reyner Wolfe in the *Oxford Dictionary of National Biography*.

⁸⁴⁷ Carter, *A view of early typography up to about 1600*, p. 101.

⁸⁴⁸ Fournier and André, 'Lettres polémiques sur la typographie', p. 46

‘Menasseh ben Joseph ben Israel, seeing the Bomberg types worn out,⁸⁴⁹ and since nothing can be imperfect for the Holy Work, arose from within the community and went out, and came to the house of an artisan. And behold, he was standing there at his work, the tools of his trade in his hand. He said to him: behold, the money is given to you and the shapes of the letters to make as is good in the eyes of the honorable and respected Michael Judah, first among the scribes, may the Lord consummate his work and may his reward from the Lord God of Israel be complete. The man swore in real writing to make them for him and for no other man. He shaped them with a burin and made them good to look at and fine to read, as perfect as if cast in gold. And there were two men who were amazed to see the completeness of the work and its beauty. It lifted up their hearts to bring to the work of printing a little Siddur, the like of which had never been since there were printers on the earth.’

This description – for all its florid quality – is unique for a depiction of a punchcutter at work during the sixteenth or seventeenth century. The engraver was in fact the punchcutter Nicolaes Briot and the types he cut set the pattern for what came to be called the *Otiot Amsterdam* or Amsterdam Letters. There has been a suggestion that the Hebrew scribal models used for the Briot Hebrew fount were from the seventeenth-century scribe Sephardic scribe Eliah ben Michael Judah Leon who was active in Amsterdam, but this hypothesis does not appear to have sufficient evidence to support it.⁸⁵⁰ However the square Sephardic hand in a surviving and signed example of Michael Yehuda Leon’s hand from 1666 shows clear resemblances to the Briot Hebrew.⁸⁵¹ The interesting point is the relatively minor dissimilarities to the Le Bé Hebrews, which can be seen in the following comparative chart. The Le Bé Hebrews are lighter, perhaps more calligraphic in character and showing the square-edged pen strokes more clearly. The Briot versions are heavier, more ‘engraved’ in character, and with less distinction between the thin and thick horizontal and vertical strokes. Dr Emile Schrijver has noted that ‘the innovation does not seem to be impressive and leaves room ... for the assumption that part of the fame of Amsterdam printed Hebrew books of the seventeenth and eighteenth centuries goes back to the quality of the paper, of the design, of the illustrations in a number of the most famous books and on the great intellectual variety of their content, rather than on the famous *Otiyyot Amsterdam* alone’.⁸⁵²

⁸⁴⁹ The word used in the Hebrew original is (מתרפות) ‘mitrapot’, which means weakened or possibly broken. This could imply that there were Bomberg types in Amsterdam at the time, but they were in poor condition.

⁸⁵⁰ Fuks and Fuks-Mansfeld, *Hebrew typography in the Northern Netherlands*, pp. 102-103

⁸⁵¹ Yeshuot Meshiho of Amsterdam, ‘Letter by 24 members of the pious society Yeshuot Meshiho of Amsterdam to hail Shabtai Tzvi as Messiah. In the handwriting of Eliah ben Michael Judah Leon. Amsterdam (1666) <<http://www.etshaimmanuscripts.nl/portfolio/eh-47-a-11/>> [Accessed 6 April 2014]

⁸⁵² Emile G. L. Schrijver, ‘*Hebrew Manuscripts after Gutenberg*’, in *As it is written: Lectures on the Art of Hebrew Manuscripts and Books* (Metropolitan Museum of Art, New York, 2010). See also John A. Lane, ‘Nicolaes Briot and Menasseh ben Israel’s first Hebrew types’, in *Bibliotheca*



Fig. 5.14: Signature in Square Sephardic hand of Eliah ben Michael Judah Leon from letter dated 1666. From the Ets Haim Bibliothek, (EH 47A11). Enlarged to same appearing size as Briot Hebrew fount.



Fig. 5.15: The largest Hebrew cut by Briot for Menasseh ben Israel compared to Le Bé's texte Hébreu. (By permission of John A. Lane, from *Nicolaes Briot and Menasseh ben Israel's first Hebrew types*)

Rosenthaliana: Treasures of Jewish Booklore, ed. by A. K. Offenbergh (Amsterdam: Amsterdam University Press, 1994)



Fig. 5.16: The title page from the *Sefer Tefilot*, Menasseh ben Israel, Amsterdam, 1627. (Bodleian Libraries, University of Oxford, Opp. add. 12mo. 107)

It can be asked why Menasseh ben Israel or his patrons for this edition did not consider using any of the Le Bé Hebrews, which would have been available from Plantin in Antwerp or Raphelengius in Leiden, and which were surely known in Amsterdam. Note the reference to the ‘worn out Bomberg types’. For whatever reason, these new Hebrews appear to have become the model for future Hebrews in the northern Netherlands. The types in the Athias Kastje (Athias Cabinet) are a good example of this development, now kept in the University of Amsterdam Special Collections. They came from the press of Joseph Athias (c. 1634 – 1700) and later came into the possession of the press of Solomon ben Joseph Proops. The undated and unattributed specimen of the Hebrew Canon (Fig. 5.20) shows the same tendency towards what Henri Friedlaender once called the ‘Didot-Bodoni-Prinzip’, that is to say an increasing exaggeration of the thick-thin strokes, perhaps appropriate to Latin letterforms, but not so for Hebrew.⁸⁵³

Three Hebrew types in what are known as the Fell types of Oxford University Press were acquired in 1637. They came from Arentz Cornelisz van Hogenacker in Leiden and include a Double Pica unpointed Hebrew, a pointed and unpointed Brevier Hebrew, and a pointed and unpointed Nonpareil Hebrew. Harry Carter noted in 1927

⁸⁵³ Friedlaender, *Die Entstehung meiner Hadassah-Hebräisch*, p. 9

that he was not sure whether or not van Hogenacker actually cut these Hebrews, but he added that 'the three Hebrew faces of the Sheldonian Press are very close to the manner of Guillaume Le Bé'.⁸⁵⁴

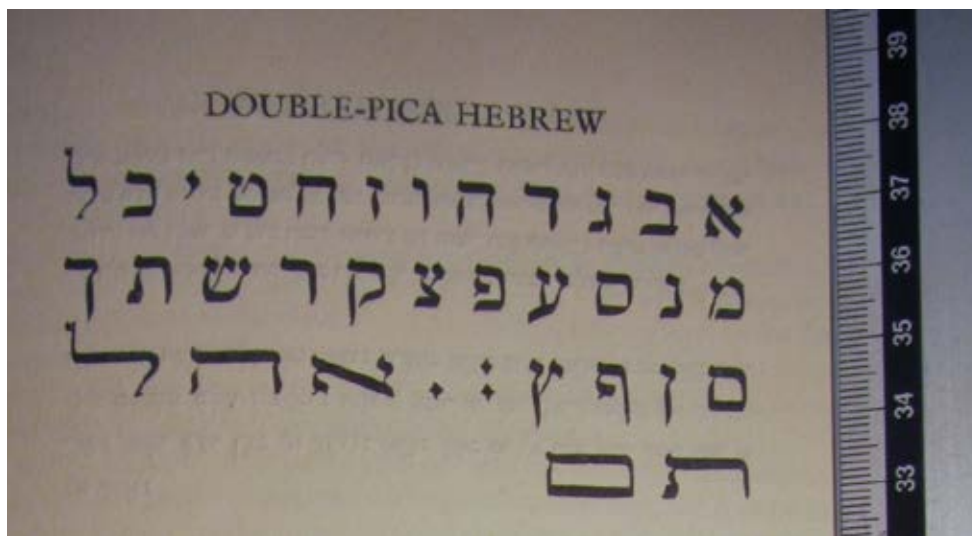

Fig. 5.17: The Fell Double Pica Hebrew. Actual size (OUP Archives)

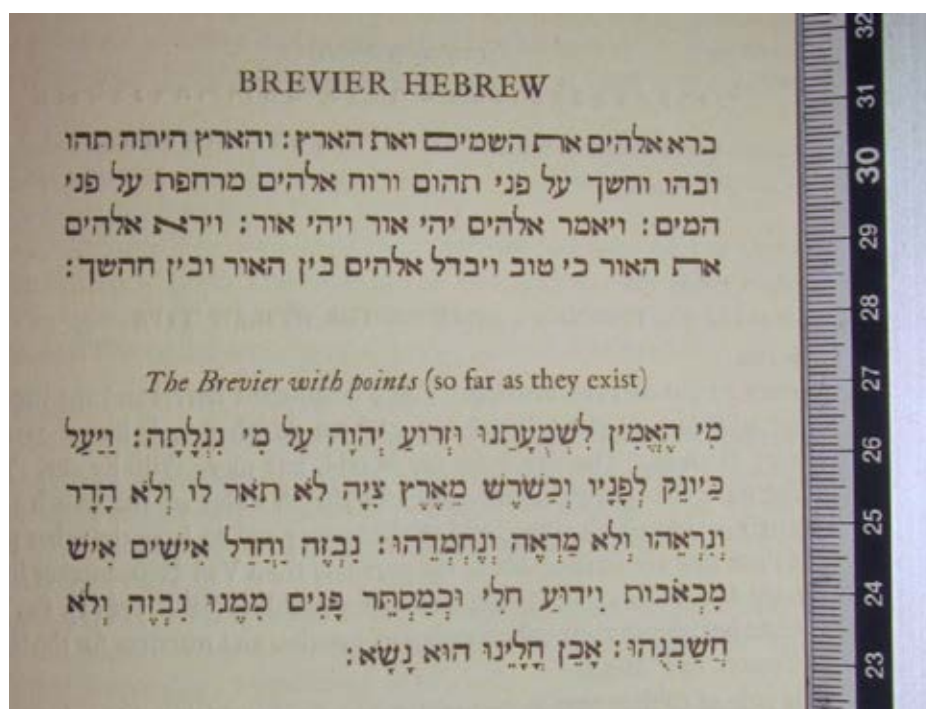

Fig. 5.18: The Fell Brevier Hebrew Pointed and unpointed text settings. Actual size (OUP Archives)

The Double pica Fell Hebrew is closest in size to HB14(S), but with distinct differences to the treatment of the shin which has a flattened base stroke, the final tsadde and the final peh. The Brevier and Nonpareil have quite differing treatments to the aleph/lamed ligature. Carter also comments that 'the Leyden types illustrate

⁸⁵⁴ Carter, *Notes towards a specimen of the Ancient Typographical Materials principally collected and bequeathed to the University of Oxford*, pp. 5-6

an early stage of the tendency to over-refinement and regimentation leading to modern Hebrew typography; they are less degenerate than the much-admired type of Menasseh b. Israel, cut about 1625 and reminiscent of the engraved models in the *Theatrum Artis Scribendi* of Judocus Hondius, published in 1594'.⁸⁵⁵

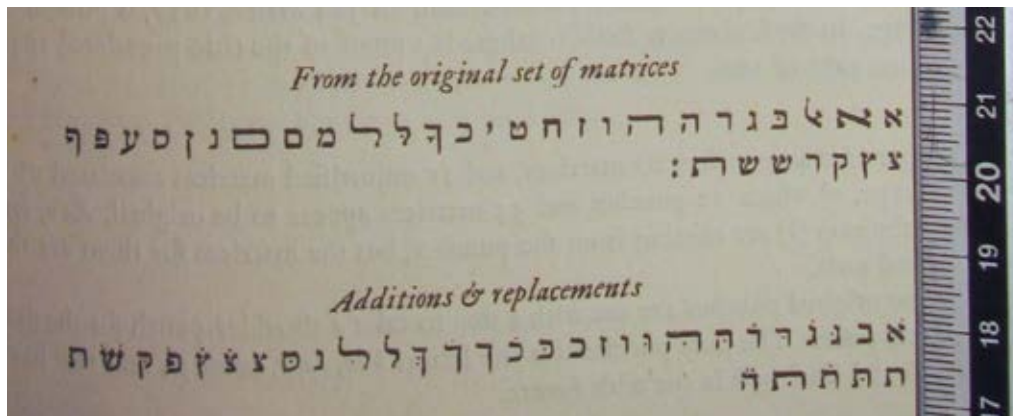

Fig. 5.19: The Fell Brevier Hebrew Alphabet from original set of matrices and additions and replacements. Actual size (OUP Archives)

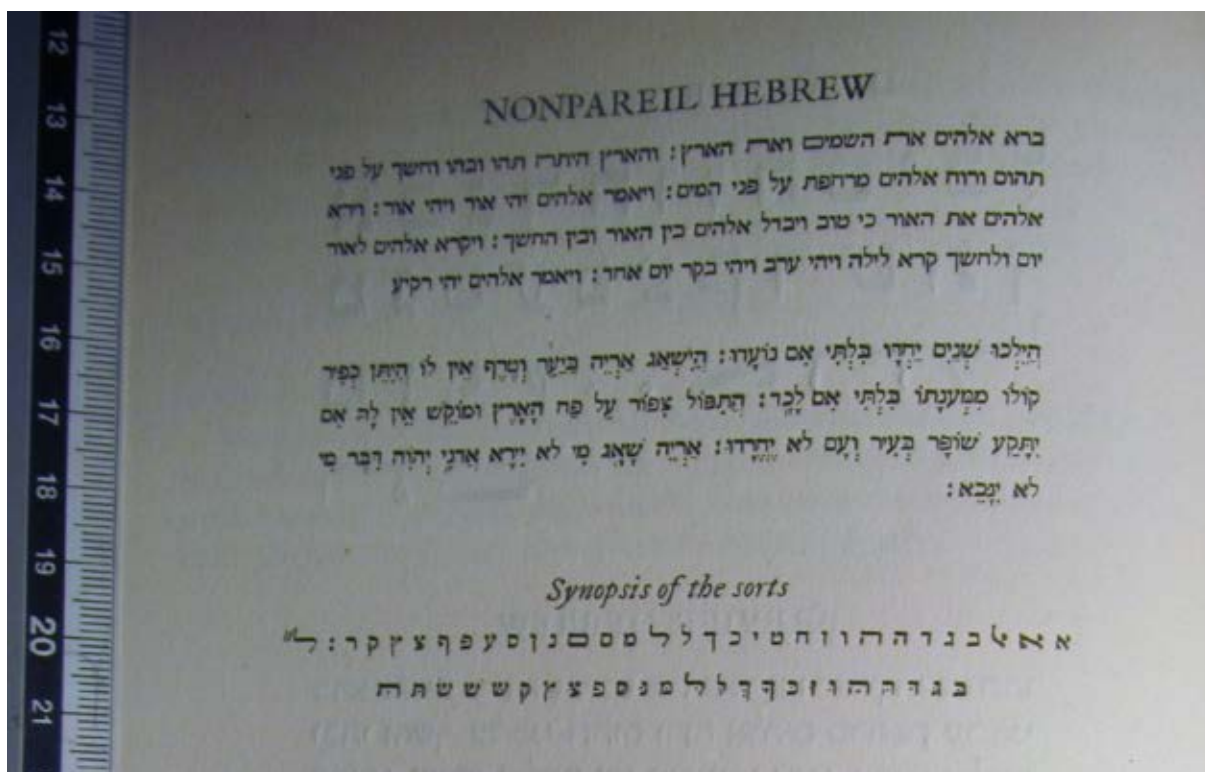

Fig. 5.20: The Fell Nonpareil Hebrew. Actual size (OUP Archives)

The influence of the Ben Menasseh Hebrews can also be seen in subsequent seventeenth-century Amsterdam Hebrews: such as the Athias Canon in the Athias Cabinet and the three Miklós Kis Hebrews from his 1685 Amsterdam specimen.⁸⁵⁶ In both these specimens it is worth noting that all upper termination strokes on the shin

⁸⁵⁵ *Ibid.*, p. 6

⁸⁵⁶ Haiman and Soltész, *Nicholas Kis: a Hungarian punch-cutter and printer 1650-1702*, p. 74

point to the left, as opposed to the Le Bé Hebrews, where the middle termination stroke always point right. This indicates a different model or a conscious attempt to differentiate these Hebrews from the Le Bé Hebrews.



Fig. 5.21: Hebrews from the 1585 Miklós Kis Amsterdam specimen. Actual Size (From Haiman and Soltész, *Nicholas Kis: a Hungarian punch-cutter and printer 1650-1702*, 1983)

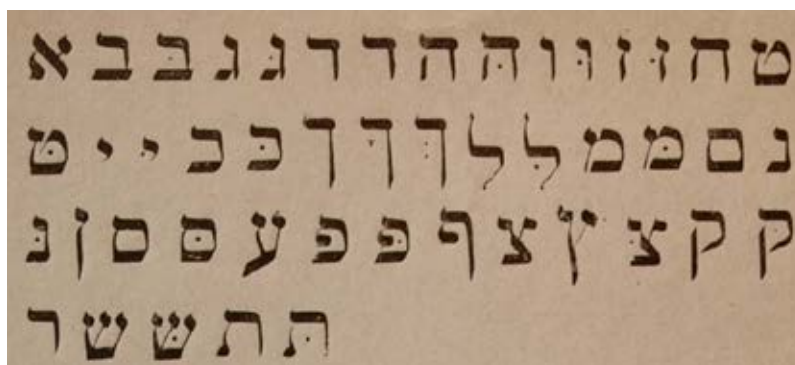

Fig. 5.22: Kanon Hebreuwsch from Drawer 35 of the Athias Cabinet. Actual Size (University of Amsterdam Special Collections)

A further example of the influence of the Le Bé types can be seen from an unexpected source: Hebrew manuscripts produced in the German-speaking lands in the eighteenth century. Here we see a scribe, the Jewish *sopher* (scribe) Aaron Wolf Herlingen, who was active in Pressburg (now Bratislava in Slovakia) and later in Vienna, where he became the 'Kaylerl. Königl. Bibliothec Schreiber in Wienn' and produced some forty known Hebrew illuminated manuscripts from about 1720. The point of interest here is that a Jewish Scribe from the Ashkenazic tradition produced illuminated manuscripts in which the lettering for the text and headings was 'inspired by Hebrews types used in Amsterdam – *be otiot Amsterdam* – using the Sephardic and *not* the Ashkenazic model for his hand. This was quite a common practice during the period beginning about 1710, whereas 'the first printers based themselves on handwritten letters, we now see the copyists following printed examples'. Aaron Wolf Herlingen appears to have followed the earlier Sephardic hands favoured by Le Bé and produced a manuscript very close in spirit to the Le Bé Hebrews.⁸⁵⁷



Fig. 5.23: Example of the title page heading from Aaron Wolf Herlingen, *Seder Hagadah shel Pesach*, Pressburg, 1726 (By permission of Adam Partridge Auctioneers & Valuers, The Cheshire Saleroom, Macclesfield Cheshire) Enlarged from original size.

⁸⁵⁷ Emile G. L. Schrijver, 'Be-Otiyyot Amsterdam: Eighteenth-Century Hebrew Manuscript Production in Central Europe: The Case of Jacob Ben Judah Leib Shamas', *Quaerendo*, 20 (1990), pp. 24, 33 and Schrijver *et al.*, *Schöne Seiten*, pp. 92-109. The Aaron Wolf Herlingen Hagadah of 1726 was recently discovered in a family home in Cheshire and I am grateful to Messrs. Adam Partridge Auctioneers & Valuers of the Cheshire Saleroom, Macclesfield Cheshire for permission to reproduce these images.



Fig. 5.24: Examples of headings and text from folio 9, Aaron Wolf Herlingen, *Seder Hagadah shel Pesach*, Pressburg, 1726 (By permission of Adam Partridge Auctioneers & Valuers, The Cheshire Saleroom, Macclesfield, Cheshire)

Originality and progression in the Le Bé Hebrews

In *An View of Early Typography*, Harry Carter made the observation about some of Le Bé's handwritten annotations that 'these comments amount to a complete negation of designing as we should understand it, and they come from one of the most skilful of artists-punchcutters of the greatest school, that of Paris in the sixteenth century'. He also commented that any discussion of it (i.e. typography) must bring to light the belief on the part of the engraver that his work was a branch of calligraphy'.⁸⁵⁸

Carter was most likely speaking from the perspective of the mid-twentieth century, when the creation of typefaces and the role of typeface designer had long since achieved the status of an independent discipline, and thus his view was that Le Bé's status was more of a skilled craftsman, who was following certain accepted calligraphic styles. These comments in fact fit in with Le Bé's oeuvre, but do not give enough credit for the sheer originality and consistency of his output. Vervliet's understanding of this statement is that Carter was 'referring to the art of imitation, which was fully accepted during the Renaissance'. Vervliet has written elsewhere that 'one should be aware that Renaissance aesthetics emphasized excellence over

⁸⁵⁸ Carter, *A view of early typography up to about 1600*, pp. 43-44. The Le Bé annotations he was referring to are in Res X 1665 folios 2, 4 and 19 and in NAF 4528 folio 14-16.

individuality and fully approved of skilful or superior imitation'.⁸⁵⁹ The true mark of Le Bé's originality is his use (and imitation) of the historical scribal Sephardic model as opposed to the Ashkenazic model of Hebrew letterforms, and his refinement of this model into an aesthetic whole and unified 'schriftbild'.⁸⁶⁰ Although Le Bé would no doubt have seen examples of the Ashkenazic model both during his early days in Paris and his stay in Venice, the evidence from Jewish scribal practice in Italy during the sixteenth century shows that it was the Sephardic model that predominated and suggests a further reasons why Le Bé would have favoured this model.⁸⁶¹

The idea of imitation as practised in the Renaissance was the use and observation of models from classical antiquity, as exemplified in the Latin terms *imitatio* and *aemulatio*.⁸⁶² It has been noted that 'copying, education by imitation, created a particular type of stylistic development in the Renaissance. The sharp, swift changes in style (and in content) of the twentieth century were, of course, unknown. Instead, one finds the slow, gradual transformation of one style into another. Whole generations of artists, in retrospect, can be seen pursuing similar stylistic and iconographic goals. From generation to generation, from pupil to master, there is change, but it is modulated and slow'.⁸⁶³ This description seems an apt way to put into perspective the transformations of Hebrew type in the sixteenth century and Le Bé's role in this process.

Carter put this idea into practice when he cut a specimen Hebrew typeface – called Bezalel – during his period as Deputy Chief Censor in Palestine during World War II. In an article he wrote for the *Palestine Post* in 1945 he wrote that 'in matters Hebrew, the Sephardim are always right. I adhere to the school which will have nothing to do with the Ashkenazic tradition in lettering'. He mentions Le Bé as 'one of the best Huguenot letter-cutters', but he is clearly harking back to the idea of imitation when he writes that 'we ought to give back to Hebrew letters what they have lost in beauty of form since the Renaissance'. He based his type on '15th and 16th century models written and printed in Southern Europe'. This would explain the two forms of the lamed, and the two versions of the shin, one with all three terminations pointing to the left, and one with the middle termination pointing right.⁸⁶⁴

⁸⁵⁹ Email correspondence 4 September 2013. See also Vervliet, *The Palaeotypography of the French Renaissance: Selected Papers on Sixteenth-Century Typefaces*, p. 165 (Vol. 161)

⁸⁶⁰ This untranslatable German term covers the 'image' of a typeface and the elements which distinguish it from other typefaces. See Jost Hochuli, *Das Detail in der Typographie* (München/Berlin: Deutscher Kunst Verlag GmbH, 1990), p. 15 where he speaks of a 'harmonische Schriftbild'.

⁸⁶¹ See page 351 of this thesis.

⁸⁶² 'Notes on Imitation and Forgery' (<<http://www.umich.edu/~engtt516/forgerysource.html>> [Accessed 4 September 2013])

⁸⁶³ Bruce Cole, *The Renaissance artist at work : from Pisano to Titian* (London: John Murray, 1983), p. 31

⁸⁶⁴ Harry Carter, 'Making a Printing-Type', *Palestine Post*, December 14 1945. The mention of Le Bé as a Huguenot is of interest, although not sustained by any evidence to date. See also Martyn Thomas, John A. Lane, and Anne Rogers, *Harry Carter, typographer* (Bath: Old School Press, 2005), pp. 18-21, *ibid*.

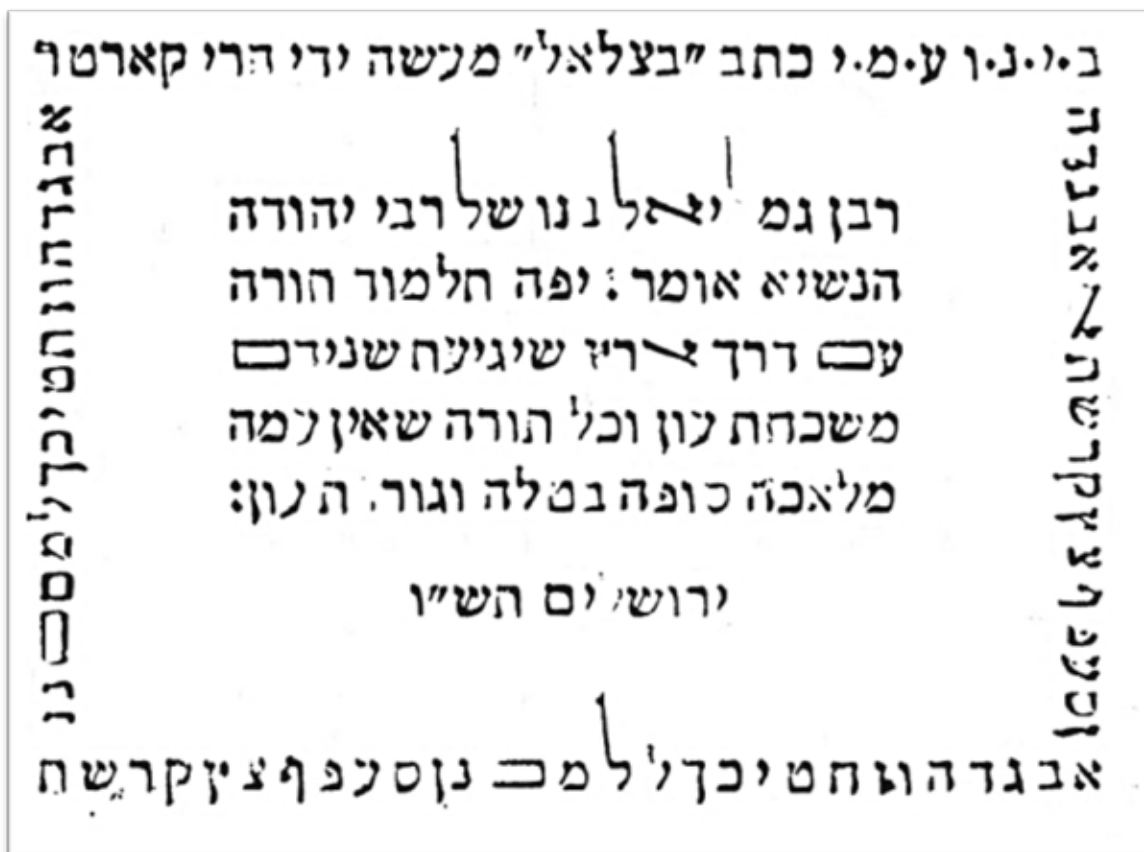

Fig. 5.25: Harry Carter's Bezalel Type (enlarged 4x) From *The Palestine Post*, December 1945.

Harry Carter's comment about the Ashkenazic tradition in lettering raises the question as to what are these traditions as seen by those Jewish scribes who write the Torah scrolls, the prayers placed in the phylactery (*tefillin* in Hebrew) or in the doorpost case (*Mezuzah* in Hebrew). These are all written by hand and follow certain very precise rules. A recent edition of these rules contains sections from five different texts describing the rules involved in writing the biblical texts and prayers.⁸⁶⁵ It should be noted that these are *not* historic alphabets based on scribal models, but are more contemporary in feel and show the influence of printed types in the flattening of the baselines. They also have the decorative 'tagin' on the upper strokes of the letters gimel, zayin, tet, nun, ayin, tsade and shin. Yet they do demonstrate the differences between the two hands and also the source of Le Bé's models which he drew on for his typefaces. The shin has the three termination strokes pointing left, a style never used by Le Bé. The Ashkenazic alphabet shows the altered angle of the pen (closer to 90°) and the increased differentiation between the horizontal and vertical strokes. It can be argued that Le Bé's contacts with Jewish scribes during his stay in Venice would have made him aware of these distinctions and provided him with reliable models to imitate. He may well have shared Harry Carter's opinion as to the aesthetic merits of the Ashkenazic tradition in lettering.

⁸⁶⁵ Rabbi Ts. Cahane, *Likut Sifrei Stam (the scribes' handbook)* (Jerusalem: Machon Daat Yosef, 1998)



Fig. 5.26: Sephardic (upper) and Ashkenazic (lower) scribal alphabets compiled from *Likut Sifrei Stam* (the scribes' handbook) 1998

One question which presents itself in such a study as this is whether there was a visible progression in the style or treatment of Le Bé's Hebrew typefaces during the course of his working career. The two diagrams which follow, showing the main recognition characters from the Le Bé production enlarged to a common viewing size and displayed chronologically, demonstrate a consistent approach to various important elements, such as ratio of vertical to horizontal stems, treatment of termination strokes, treatment of ascenders and descenders, and placement of the middle termination stroke in the character shin. The same holds for the Rashi characters, in particular the final nun, which is a key recognition factor to distinguish the Le Bé Rashi typefaces from those used by Bomberg in his editions. The final specimens – HB 17 (S) and HB20 (R) – do display differences in some of the elements, yet it needs to be stressed that they were engraved in wood by Mahiel du Boys, probably following the original designs by Le Bé. ⁸⁶⁶

⁸⁶⁶ I am indebted to the study of the late Kay Amert on Simone de Colines, for the idea of a comparative presentation of the differences between different typefaces, for which she used a superimposition method. This method was not possible, hence I used a more conventional means to demonstrate the similarities. See Kay Amert and Robert Bringhurst, *The scythe and the rabbit : Simon de Colines and the culture of the book in Renaissance Paris* (Rochester, New York: Cary Graphic Arts Press, 2012), pp. 139-149

Thus it can be said with some certainty, that Le Bé did *not* vary his basic concepts in his Hebrews from the beginning of his career in Venice until his later years in Paris. He may have seen this model as his trademark, and one which clearly differentiated his typefaces from others in use or circulation during his lifetime.



Fig. 5.27: Comparison of Le Bé's Hebrew Sephardic typefaces



Fig. 5.28: Comparison of Le Bé's Hebrew Rashi typefaces

Closing discussion

It is hoped that this thesis has been able to provide at least partial answers for some of the main questions relating to Guillaume I Le Bé. A major problem has been finding documentary evidence, especially concerning his apprenticeship, his stay in Venice and Rome, his court case against Giustiniani, his business links with other printers in Paris and the people to whom he supplied type either in the form of matrices or cast type. Due to lack of documentary evidence, provisional hypotheses have been made for many of these queries. As can be seen from the list of documents in Appendix E, there are more documents than originally known, which mention his name or family. Nevertheless much is still left to supposition. Given the present state of research and extant documentation, the best approach was to give as broad a picture as possible of his life, activities and contacts. The main aim of this thesis has been to provide a detailed description of the distinct Hebrew types identified in the two documents, which can give a firm basis for attributing Hebrew types found in

contemporary or subsequent publications by other printers of the sixteenth and seventeenth centuries. This follows the model set out by Vervliet in his major descriptive works.

His role was not only as a punchcutter, but also as a paper merchant, and to a lesser extent as a printer and publisher. These roles were continued by his son and successor, Guillaume II Le Bé. It is still not clear at what point the Le Bé foundry became a working entity, yet he appears to have juggled these various roles throughout his life.

By the next century Guillaume II Le Bé clearly viewed himself as a type founder. Three letters to founders in Lyons and Geneva dated from 1614 have survived in which Guillaume II Le Bé, Jacques de Sanlecque and Jean Méjat were actively attempting to protect the monopoly of Parisian type foundries against certain Booksellers who were trying to obtain type behind their backs.⁸⁶⁷ A further case was brought in December 1655 by 'les Syndic et Adjoints des Marchands Libraires, imprimeurs et relieurs de cette Ville de Paris' and Antoine Vitré (described as a 'imprimeur ordinaire du Roy et du Clergé de France') against Guillaume II Le Bé (described as a 'Marchand Libraire, fondeur de caractères d'imprimerie à Paris') concerning the prices of type at what was claimed to be a 'prix si exorbitant' that they would be forced to 'abandonner les presses et impressions'. This type of trade monopoly was not unknown in the sixteenth century and later, as can be seen in the complaints against the Ballard dynasty and their monopoly on the printing of music.⁸⁶⁸

It is also clear from his various properties outside Paris and his household contents that Guillaume I Le Bé had established himself in the Parisian bourgeoisie by the end of his life. Furthermore, he appears to have steered a middle path through the troublesome times of the French Wars of religion in the last part of the sixteenth century. He and his family led what was outwardly a 'catholic' existence, although he most certainly had both personal and professional contacts with people who were known Protestants.

The two documents are evidence of only one side of Guillaume I Le Bé's professional activities. His interest in Hebrew must have stemmed from his early years as an apprentice with Robert I Estienne and subsequent years in Venice, where he met and was exposed to Jews and their scribal traditions and practices. His skill in punch cutting became evident as soon as he established himself in Venice and produced his first Hebrews.

⁸⁶⁷ Lettres écrites par les Fondateurs de ceste ville de Paris, pour la conservation du Monopole fait entre eux, au preiudice des Marchands Libraires & Imprimeurs de ceste ville and Sentence du Lieutenant particulier relative à l'action indendée par Guillaume Le Bé, libraire et dondeur de lettres, contres Antoine Vitré, imprimeur ordinaire du Roi et du Clergé, et les syndic et adjoint', BnF, Collection Anisson, 22117 (Graveurs et Fondateurs de caracteres (1583-1764)

⁸⁶⁸ See page 148 of this thesis.

APPENDICES

Appendix A: Comparative chart of the Le Bé Hebrew typefaces sorted according to size

Type Number	Size in mm	Specimen alphabet
Hb 16 (R)	1.0	אבגדהוזחטיכךלמנסןסעפףצקרקשתא"ף
Hb 15 (S)	1.0	אבגדהוזחטיכךלמנסןסעפףצקרקשתא"ף
Hb8 (R)	1.1	אבגדהוזחטיכךלמנסןסעפףצקרקשתא"ף
Hb46 (S)	1.1	אבגדהוזחטיכךלמנסןסעפףצקרקשתא"ף
Hb36 (R)	1.2	אבגדהוזחטיכךלמנסןסעפףצקרקשתא"ף
Hb49(R)	1.3	אבגדהוזחטיכךלמנסןסעפףצקרקשתא"ף
Hb5 (R)	1.5	אבגדהוזחטיכךלמנסןסעפףצקרקשתא"ף
Hb40 (S)	1.6	אבגדהוזחטיכךלמנסןסעפףצקרקשתא"ף
Hb47 (R)	1.6	אבגדהוזחטיכךלמנסןסעפףצקרקשתא"ף
Hb30 (S)	1.8	אבגדהוזחטיכךלמנסןסעפףצקרקשתא"ף
Hb19 (S)	1.9	אבגדהוזחטיכךלמנסןסעפףצקרקשתא"ף
Hb35 (S)	1.9	אבגדהוזחטיכךלמנסןסעפףצקרקשתא"ף
Hb38 (S)	1.9	אבגדהוזחטיכךלמנסןסעפףצקרקשתא"ף
Hb41 (S)	1.9	אבגדהוזחטיכךלמנסןסעפףצקרקשתא"ף
Hb43 (R)	1.9	אבגדהוזחטיכךלמנסןסעפףצקרקשתא"ף
Hb2 (R)	2.0	אבגדהוזחטיכךלמנסןסעפףצקרקשתא"ף
Hb7 (R)	2.0	אבגדהוזחטיכךלמנסןסעפףצקרקשתא"ף
Hb34 (R)	2.0	אבגדהוזחטיכךלמנסןסעפףצקרקשתא"ף
Hb31 (R)	2.0	אבגדהוזחטיכךלמנסןסעפףצקרקשתא"ף
Hb44 (R)	2.0	אבגדהוזחטיכךלמנסןסעפףצקרקשתא"ף
Hb42 (S)	2.1	אבגדהוזחטיכךלמנסןסעפףצקרקשתא"ף
Hb6 (S)	2.1	אבגדהוזחטיכךלמנסןסעפףצקרקשתא"ף
Hb29 (S)	2.2	אבגדהוזחטיכךלמנסןסעפףצקרקשתא"ף
Hb37 (S)	2.3	אבגדהוזחטיכךלמנסןסעפףצקרקשתא"ף
Hb48 (S)	2.3	אבגדהוזחטיכךלמנסןסעפףצקרקשתא"ף
Hb4 (S)	2.3	אבגדהוזחטיכךלמנסןסעפףצקרקשתא"ף
Hb18 (R)	2.3	אבגדהוזחטיכךלמנסןסעפףצקרקשתא"ף
Hb39 (S)	2.5	אבגדהוזחטיכךלמנסןסעפףצקרקשתא"ף
Hb11 (S)	2.5	אבגדהוזחטיכךלמנסןסעפףצקרקשתא"ף

Type Number	Size in mm	Specimen alphabet
Hb24 (S)	5.5	אבגדהוזחטי כךלמסנזסע פףצץקרשת
Hb14 (S)	6.0	אבגדהוזחטיכךלמסם נזסעפףצץקרשת:
Hb50 (A)	6.0	אבגדהוזחטיכךל מסנזסעפףצץקרשת
Hb27 (S)	6.0	אבגדהוזחטיכךלמסנזסעפףצץקרשת-
Hb12 (S)	15	אבגדהוז
Hb20 (R)	17	אבגהוזק
Hb21 (S)	17	אבגדהוז
Hb 17 (S)	31	אבגד

Appendix B: Comparative table of text and titling Body sizes

This table is based on the following sources: H. D. L. **Vervliet**, *French Renaissance Printing Types: A Conspectus* (London: The Bibliographical Society, 2010); T. B. **Reed** and A. F. Johnson, *History of the old English Letter Foundries: with notes Historical and Bibliographical on the Rise and Progress of English Typography*. Revised and enlarged edn (London: Faber, 1952); Giuseppina **Zappella**, *Il libro antico a stampa (Parte Prima)* (Milano: Editrice Bibliografica, 2001); Friedrich Bauer, *Handbuch für Schriftsetzer ... Dritte neu bearbeitete Auflage, etc* (Frankfurt am Main: Verlag von Klimesch & Co., 1910); Dr. Leon **Voet** and Raymond H. Kaye, *The Golden Compasses. A history and evaluation of the printing and publishing activities of the Officina Plantiniana at Antwerp, etc*, Vol. 2, (Amsterdam: Vangendt & Co, 1972); Guillaume Le Bé, *Sixteenth-century French typefounders: the Le Bé memorandum*. ed. by Harry Carter, (Paris and Oxford: André Jammes, 1967), and Karl Lothar **Wolf**, *Terminologische Untersuchungen zur Einführung des Buchdrucks im französischen Sprachgebiet*, (Tübingen: Niemeyer, 1979), pps. 97-123. The sizes mentioned by Le Bé in his annotations and in the 1730 Inventory are given to provide a possible equivalency and the sizes in Pica points are intended only to show approximate size, as the actual sizes could vary quite widely. The colour coding refers back to the original source:

Old English	Old French	Italian	Dutch/Flemish	Le Bé	Size in UK/US Typographic points
TEXT FACES (Body types) SIZES					
Diamond	Diamant	Parigina	Robijn/Diamand		
Pearl	Parisienne /Sédanoise/Perle	Parmigianina	Joly/Jolie/Peerl		5/6.1
Nonpareil	Nonpareille	Nonpariglia or Nonpariglia	Nonparel or Nompareille	Nompareille	6/5.8
Minion	Mignonne	Mignona	Colonel /Coronelle	Mignonne	6.5
Brevier	Petit-texte	Testino	Brevier/ Bible	Textin?	7.5/7.6
Bourgeois	Gaillarde	Garamoncino	Burgeois/Galjart/ Colineus	Petit Texte/Textin?	8.5/8.6
Long Primer	Petit-romain	Garamone	Garmond / Garamonde /Bourgeoise/Petite Ascendonica	Petit Romain	9.5/9.4
Small Pica	Philosophie	Filosofia	Descendiaan /Philosophie/Descendiane	Philosophie	10.5/10.3
Pica	Cicéro	Lettura	Mediaan/ Mediane Petite Augustine	Cicéro/Moyenne?	11.5/11.3 12.3
English	Saint-Augustin	Silvio	Augustyn /Augustine	Saint Augustin	13/13.4
Large English	Gros-texte	Soprasilvio		Gros texte	15
			Nouveau Texte/Petit texte		15.5
Great Primer	Gros-romain	Testo	Text /texte/Vrai texte/Gros texte. Gros Romain	Gros Romain/Testino	16.5/16.6
			Petite Parangonne		17.7
			Reale		18.5
Paragon	Petit-paragon	Parangone	Parangon /Parangonne/Vraie Parangonne/Grosse Parangonne	Parangon/Petit Parangon	19/18.7
			Ascendonica		20 Voet
Double	Gros-paragon	Ascendonica	Dubbelde Descendiaan	Gros Parangon	20

<i>Old English</i>	<i>Old French</i>	<i>Italian</i>	<i>Dutch/Flemish</i>	<i>Le Bé</i>	<i>Size in UK/US Typographic points</i>
Pica					
Two-line Pica	Palestine	Canoncino	Dubbelde Mediaan		22.5
			Petit Canon		27.2
Two-line English	Petit-canon	Sopracanoncino	Dubbelde Augustyn	Petit canon	28.5
	Canon		Trismégiste/ Moyen Canon	Canon	
					32.2
Two-line Great Primer	Trismégiste	Canone	Kanon		36
Two-line Double Pica	Gros-canon	Corale	Groote Kanon/Gros Canon/Gras Canon	Gros Canon	42.5/41
			Canon d'Espagne		47.5
French Canon	Double-canon	Reale	Parys Kanon	Double canon/Gros Double canon	51
Five-line Pica					60
Six-line Pica	Triple-canon				72
Seven-line Pica	Grosse Nompaille			Grosse Nompaille	82
			La plus Grande Romaine		83
Eight-line Pica					95
Nine-line Pica					110
Ten-line Pica					123
Eleven-line Pica					136
			Gros Flamand		155
Twelve-line Pica					160
DISPLAY or TITLING SIZES					
Two-line Pearl	Deux-points de Parisienne				9.5
Two-line Nonpareil	Deux-points de Nonpareille				11.5
Two-line Minion	Deux-points de Mignonne				13
Two-line Brevier	Deux-points de Petit-texte			Lettres 2 points Petit-texte	15
Two-line Bourgeois	Deux-points de Gaillarde				16.5
Two-line Long Primer	Deux-points de Petit-romain			Lettres 2 points Petit-romain	19
Two-line Small Pica	Deux-points de Philosophie				20
Two-line Pica	Deux-points de Cicéro				22.5
Two-line	Deux-points de Saint-			Lettres 2 points St-	28.5

<i>Old English</i>	<i>Old French</i>	<i>Italian</i>	<i>Dutch/Flemish</i>	<i>Le Bé</i>	<i>Size in UK/US Typographic points</i>
English	augustin			Augustin	
Two-line Great Primer	Deux-points de Gros-romain				36
Two-line Double Pica	Deux-points de Gros-parangon			Lettres 2 points Gros-Parengon	42.5
Four-line Pica	Deux-points de Petit-canon				51
Five-line Pica	Deux-points de Gros-canon				60
Six-line Pica					72
Seven-line Pica					82
Eight-line Pica					95
Ten-line Pica					110
Eleven-line Pica					123
Thirteen-line Pica					136
Fifteen-line Pica					160

Karl Wolf gives a slightly different tabular listing of the type sizes commonly used in the sixteenth century, based on the descriptions and sizes as used in the Plantin Inventories. His comparative type sizes are in Didot points.⁸⁶⁹

<i>Designations and Size as used by Plantin</i>	<i>Typographic Points (Didot)</i>	<i>Designations and Size as used by in the 19th century</i>
	3	Diamant
	4	Perle
	5	Parisienne or sédanaise
Nompareille (Petite Nompareille)	5.3	
Jolie	5.6	
Coronelle (Mignonne, Grosse Nompareille)	6	Nonpareille
Bible (Petit Texte), Bréviaire, Gaillarde)	7	Mignonne
	7.5	Petit texte
Colineus (Bourjoise)	7.9	
	8	Gaillarde
Garamonde (Petit Romain, Petite Ascendonica, Bourjoise)	8.7	
	9	Petit Romain
Philosophie (Descendiane)	9.5	
	10	Philosophie
Mediane (Cicero)	10.5	
	11	Cicero
Petite Augustine	11.5	
	12	Saint-Augustin
Augustine (Vraie Augustine, Grosse Augustine)	12.5	

⁸⁶⁹ Wolf, *Terminologische Untersuchungen zur Einführung des Buchdrucks im französischen Sprachgebiet*, pp. 100-101

<i>Designations and Size as used by Plantin</i>	<i>Typographic Points (Didot)</i>	<i>Designations and Size as used by in the 19th century</i>
	13	Saint-Augustin.
	14	Gros texte
Nouveau Texte (Petit Texte)	14.5	
	15	Gros texte
Texte(Vrai Texte, Gros Texte, Gros Romain)	15.5	
	16	Gros Texte
Petite Parangonne	16.3	
Reale	17.3	
Parangonne (Vraie Parangonne, Grosse Parangonne)	17.5	
	18	Gros Romain
Ascendonica	18.5	
	20	Parangon
	22	Parangon
	24	Palestine
Petit Canon	25.5	
	26	Petit Canon
Moyen Canon	30.5	
	36	Trismégiste
Gros Canon (Gras Canon)	38.2	
	40	Gros Canon
Canon d'Espagne	44.5	
	48	Gros Canon
	56	Double Canon
	72	Double Trismégiste
La Plus Grande Romaine	78	
	88	Triple Canon
	96	Grosse nonpareille
	100	Moyenne de fonte
Gros Flamand Lettre	144	

Appendix C: Facsimiles, Transcriptions and Translations of the Le Bé document NAF 4528

This appendix contains a complete page-by-page facsimile of the Le Bé Document NAF 4528, together with a transcription of the annotations and a translation. The transcriptions are based on the two Omont articles of 1887 and 1889, but modified to make them more consistent with the actual spelling and style of the original.⁸⁷⁰ The transcription symbols used are a conflation of the 'Leiden' and 'Scriptorium' systems. Some symbols used by Le Bé are not available, such as the Renaissance 'et' sign, and thus other symbols have been substituted.⁸⁷¹

(xxx) = expanded abbreviations

<xxx> = textual omissions

((xxx)) = Textual interpolation

†xxx† = Problematical reading

[xxx] = cancellations

[[xxx]] = Accidental loss

/ signed used by Le Bé – most probably to indicate a comma (virgule), although it is not clear whether this was a typical characteristic of scribal hands in France in the sixteenth century.⁸⁷²

I have used in part the transcription of these annotations as transcribed by Harry Carter in an undated manuscript in the Harry Carter papers in St Bride Library.

These facsimiles are reproduced with the kind permission of the Bibliothèque nationale de France.⁸⁷³

⁸⁷⁰ Omont, *Specimens de caractères hébreux gravés à Venise et à Paris par Guillaume Le Bé, 1546-1574*, Omont, *Specimens de caractères hébreux, grecs, latins, et de musique gravés à Venise et à Paris par Guillaume le Bé, 1545-1592*.

⁸⁷¹ Brown, *A guide to western historical scripts from antiquity to 1600*, pp. 5-7

⁸⁷² See Gabriel Audisio and Isabelle Rambaud, *Lire le français d'hier: manuel de paléographie moderne, XVe-XVIIIe siècle*. Quatrième édition (Paris: A. Colin, 2008). See also Beáta Varga, 'Écrire: transcrire ou bien orthographier? Problèmes d'analyse phonétique des textes écrits du Moyen Âge et de la Renaissance', *Revue d'Études Françaises*, No 7 (2002), p. 96

⁸⁷³ Email dated 28 December 2011 from M. Philippe Bretagnon, Département de la reproduction (Pôle redevance), Bibliothèque nationale de France.

En l'An 1545. sous La Royne Catherine De Luy 1546. en La Cite de
Genève. Fay faillie par ce L'Hebreu ditte La Tete du
Talmud, qui est la premiere de tous ouvrages. de la Loy de Mo. avec
a huit pages.

הקולה היא הערך הגדול הכלילת יופי הקנה אלם ציטרל וסלימה בתורה
וכמעשים וכדבנת לבב וניהסים בעושר ובכספים. היא עיר גדלונק
המעטירה ויבא בית ק"ש הגדול הקניף הקדון היאש והגולה והכותרת
premiere I I

Hb2 (R)

חוקת הבתים והבורות והשינין והמערות והשובכות הנם
צאות ובית הברין בית השל קהת שלש שנים ואינה מויה
חין והעבדים וכל שהוא עושה פירות תדירחותקן שלש
ליות רבי ישמץ מאם רוחשנים מיום ליום שרח הבע
בראשונה ובאחרונה ושניה עשר חבש באמצע היות
חדש רביס עקיבא אומר חדש בראשונה וחדש באחרון
ויבחדש באמצע הרי יחדש מאבי ישוט מעאת באם
לבן אבל בשרה אילן כנחדשים תבואתו טסק את יתי
כנסך אתקייצו הם אילן אפזנ אט צגבף ספט בשרה נעפץ
גוליאלטום ליבי צרפתי : 1545. & +6

Hb1(S)

ידעו ונומד ולפטרו בלא כלום אי אפשר כי מנות המלך עלינו ומלאכת
שמים היא ומה לעשו אלא כהלך חושי ונעשה אכחנו את אשר תיבוא ידנו
ולא מנאנו כי אסבסדר מועד וכרר נעשים ועל צדאחרים חלו זקינו
פני חמנים הגדולים אשר צבסרקוסטה ישמרס נורס להעתיק ויבנו את
יועף לאמר אזר כא כנבר הלניך לעשות מנות גבירנו הגדולים אלופנו
מסובלים : ואני הנעיר בבית אבי יוסף בר יצחק כבת בן אלופלא
דנתי אכתי למלאת יוכו גבירי אלופי ומאמרס ולהעתיק הסדר הזהסבדר
מועד שמתו מונותי ובו כפלו הכלי כיד אלהי הטובה עלי ומאת האנשוכן
רדודו בהל מועד וידי לים וכוסלים סועד ויחזיק כל לב וזחל ורועד



Hb2 (R)

Fay commandé cette Lettre sur l'Hebreu ditte la Tete de la Lettre du Talmud
a Genève l'An MDCXLV. au temps de la regnante du Secondissime Roy
François Donat. Par le Magnifique Messie Mauro Antsonie Justmanyschitz
En luy imprimé en Hebreu six et sept au quatrain de Hebra. en la Rue des
Cinq, auprès la Maison de Dieu. Contente par My Luy Hebra profonice
aux frantz a ouvrages, l'Hebreu faulx que a unumoy araba au purlleant
trant a portants de l'Hebra - HEBRAÏQUE. a aux livres dicelle Langue avec
que sa resposseur fut de tous l'Hebra de l'Hebra de l'Hebra de l'Hebra

BIBL. NAT. 655
PARIS
SERVICE PHOTOGRAPHIQUE
BIBL. NAT. 655
PARIS
SERVICE PHOTOGRAPHIQUE
REPRODUCTION INTERDITE

Transcription of the annotation

(above) En l'an 1545, vers la fin, & au cōmencemē̄ de lan 1546, en la Cité de Venise, jay taille & grave ceste Lettre Hebraique ditte le Texte du Talmuth, qui est la premiere de mes ouvrages, Aage lors de 20 ans & huict moys.

(in another hand) premiere

(below) Jay commence ceste Lettre susditte dicte le Texte de la lettre du Talmuth a Venise, en Novembre 1545. au temps de la creation du Serenissime Duc Francois Donat. Pour le Magnifique Messer Marco Anthonio Justinian, gentiho (mme) venitien. En son Imprimerie hebraiq(ue), size p(ou)r lors au quartier de Realte. en la rue des Cinq, auprès la Justice vieille. Conduitte p(ar) un M(esse)r Leon, Hebreu, parsonnier au fraitz & ouvrages, hōme fantasque & aucunemeñ entendu aux meilleurs traitz et portraitz de lescripture –HEBRAIQUE, et aux livres d'icelle langue, encore que sa profession fust de tenir boutique de fripperie dhabitz vielz & neufz.

Translation of the annotation

Towards the end of the year 1545 and the beginning of the year 1546 in the city of Venice, I engraved and cut this Hebrew letter, called a Texte du Talmuth, which is the first of my works, when I was 20 years and eight months old.

I began the above characters, called the text of the Talmuth, in November 1545, at the time of the election of the most serene Duke Francesco Donato, for the most exalted master Marco Antonio Giustiniani, Venetian nobleman, in his Hebrew print shop, then situated in the Rialto quarter, in the Calle dei Cinque near the Giustizia vecchia. It was directed by a Master Leon ... a Jew and partner in the costs and the works, an extraordinary person and particularly knowledgeable about the best shapes and figures of Hebrew script and of books in that language, although by profession he maintains a used- and new-clothing shop.

Hebrew source:

Babylonian Talmud, the Tractate Bava Batra, Chapter 1, Midrash 1. Final line is Le Bé's imprint.

Cette autre Lettre est des plus rares La Muzette - 1 de 2
La seconde de nos ouvrages. Elle est aussi a double-pour
produit Signe M. Mauro (butonni) Justinauy de Lay
1546.

מזמור לאסף

2

Hb3 (S)

אלהם באו גוים בנחלתך טמאו ארת היכל
קדשך שמו את ירושלם לעיים נתנו זאת
נבלת עבדיך מאכל לעוף השמים בשר
הסידך להיותו ארץ שפכו דמם כמים
סביבות ירושלם ואין קבר היינו הרפה
לשכנינו לענו וקלם לסביבותינו עד מזה
יהודה האנף לנצח תבער כמו אש קנאתך
שפוך ח תך אל הגוים אשר לא ידעוך ועל
ממלכות אשר בשמך לא קראו כי אבל את
יעקב ואת נוהו השמו אל תזכר לנו עונת
ראשנים מהר יקדמונו רחמיך כי דלונו כאד
עזרנו אהי ישענו על דבר כבוד שמך והצילנו
וכפר על חטאתינו למען שמך למה יאמרו
הגוים איה איהם ודע בניים לעינינו נקמת
דס עבדיך השפוך תבא לפניך אנקת אסיר
כנדל זרועך הותרי בני תמותה והשב
לשכנינו ש תים אל חיקם הרפתם אשר
הרפוך יהוה ואנחנו עמל וצאן מרעיתך
גודה לך לעולם לדור והור גודה תהלתך

Hb4 (S)

גוליאלמו ליבי צרפתי 1546

2

Transcription of the annotation

**Ceste autre lettre cy dessoubz, nōmee La Moyenne /est la seconde de mes ouvrages.
Taillee aussi a Venise pour le predict Seign(eur) M(esser)/ Marco Anthonio Justinian
en l'an 1546**

Translation of the annotation

**The other character shown below called a Moyenne is the second of my creations,
also cut in Venice for the aforementioned Signor Master Marco Antonio Giustiniani,
in the year 1546.**

Hebrew source:

Psalms 79: 1-5. Final line is Le Bé's imprint.

La 3^e Lettre de Jay tailler & graveur de la Bible de
deffouly. Membre la Confrérie Mayenne / Tailler
pour Maye ou May de Parisse fils de Jacob de
Parisse Tailler avec deffouly le 1547

3

כונתי היתה לשמי כלכד : וכן איהו גבור שראוי שיתהלל בגבורתו הכובד את יצרו : שכל טוב ארך אפי מעבור
סבי הוי פיר' דקרא טוב ארך אפים הבא מעד הגבורה של כבוש היצר לא מעד רכות הטבע וכן מושל ברומן
כשבא מלכוד עיר מן העלך של אחר שבגש את העיר וכאן לידו האכסום המורד' בו מושל ברומן ואיהו הרגן :
איהו עשיר הראוי לו להתהלל בעשרו השמח בחלקו : איהו מכובד לפי ששלשה דבר' טובי הללו שכוכו
לעיל שהם החכמה והגבורה והעושר הזוכה בהם הוא ככד מעצמו בענין להים ואדם ואף אם הכדיות לא
יבדוהו בעבורם לכך חסד התב' לזה ואפי' שיש בו המד' הללו והוא ככד בעצמו מה ועשה ויהיה מכובד
מאשרי' מכבד את הכדיות : כי מכבדי אכבד והדבר' קו ומה הקב' שהוא מלך הכבוד וכל מה שבר' בעולמו
לא בר' לא לכבודו מכבד את מכבדיו קו לב' יאמנו ויקלו למדמו ענותמותו של הקב' לא אמר' וכו' אקלל לא
יקלו מעצמם וככבוד הכדיות הקפיד יותר שכל ומקללך יאמר : ב שמונה גורדת מנוה כך מנהגו של עולם
העו' מנוה אמת כוח לו לעשו אחר' והמתחיל בעביר' קשה לפרוש מהם ועוד ששכר מנוה מנוה שמן השמים
משיי' ומזויכו ביד מו שעשה מנוה אמת שיעש' אחרת' כדי לתת לו שכר על שתי' וכן שכר עביר' וכו' : פ' א'
שכר מנוה מנוה שכל מה שאד' משתכר ומתענג בעשיית המנוה כחשב לו למנוה בפני עצמו וכונטל שכר על
המנוה שעשה : ועל העונ' וההכאה שנהנה בעשייתה : ושכר עבירה עבירה והשכר וההכאה שמונע' לו לאדם
בעשיית העבירה כחשבת לו בעבירה בפני עממה ולוקה על העבירה שעשה ועל השכר וההכאה שקבל
בעשייתה : ג אל תהי' בו לכל אדם לומר מה יוכל פלו להזיק לי : ואל תהי' מפליג מרחיק לכל דבר שיש
לחוש עליו אל תאמר רחוק הוא סיהיה ואין לדאג ממנו : ד מאד מאד הוי שכל אדם אף על פי
שבשאר מדות הדרך האמצעית היא המשובחת בעדת הגאון אינו כן אלא יטה לקט' האדרון של שפלות

Hb5 (R)

Mayent par Justice cette Lettre pour la forme, Je may ay par fait
deffouly par devant may may just au deffouly avec aux parolites
ains au 15^e jour fevrie de l'année de ceste Lettre funder & tailler
& me fait ainsi est l'année de grand procès entre Saif' Mr Maye & Mr de

Transcription of the annotation

'La 3e Lettre q(ue) jay taille et gravee est la glose cy dessoubz. Nōmee la cursive moyenne / Taillee pour Mazo, ou May de Parensse, filz de Jacob de Parensse, hebreux, au dit Venise, en l'an 1547.

Nayant pas justifie ceste lettre pour la fonte, je nen ay fait despreuve, partant(pourtant?) mon nom nest au dessoubz cōme aux precedentes, ains cecy est d'un feuillet dun Livre de lad(itte) Lettre fondu p(ar) un Allemant et me fut cause ceste lettre d'un grand proces cōtre le seig(neu)r m(esse)r Marco Anthonio Justinian.

Translation of the annotation

The third character that I engraved and cut is the glose shown below, which is called a moyen cursive, cut for Mazo or May de Parensse (i.e. Meir di Parenzo) son of Jacob of Parenzo, a Jew and cut in [the city of] Venice in the year 1547.

Not having myself justified the matrix for casting, I do not have a specimen of it showing my name at the end as with the previous specimens. Thus this specimen is from a leaf of a book of the same character cast by a German and was the cause of a major court case against the Nobleman Master Marco Anthonio Giustiniani.

Hebrew source:

Mishnah, Tractate Avot, Chapter four, a commentary on the Mishnah by Ovadia of Bartenura,

Ce petit livre s'appelle est La 4. qui est fait en
Ceste grosse gloze est La 5. qui est aussi fait en
pour le traduire Maggu ou Mago. i. Mag de paraisa
1547

בשר שנמלח ושהה כדי מליחה ושמוהו בקדירה לבשל בלא הדחה
מותר שכבר פלט דמו ולא נשאר רק מעט דם מן המלח ואותו הדם
בטל בס' אין כך שום חתיכ' שנמלחה ושהתה כדי מליחה שלא יהא
בה ס' כנגד דם שעל המלח כדגש' שהמים שבקדיר כמוק מטורפין
לבטל הדם אבל אין

Hb10(S)

שהורח ונמלח ושהה **בשר**

מדי מליחה ואחר כך
הניחו אותה לבשל בלא הרחה מית'
אם יש ס' בהתיכ' ובמני ובתבשיל כנגד
לחלוה' דם ומלח שעל החתיכ' מבחוץ
לפי שאין חמלט הנרב' מבטוין נאסר
אם בשביל דן הנבלע בו אב' לא יאסר
יותר נאלו היה המרה הנרב' מבחוץ
כולו דם דהוי בטל בששים ולא שייך
בנין לדמורת לתבלין שלעו' דעבידן
טעמיה ולא בשישי' שגם המלחף

Hb6(S)

נריך מטורף המים כי
כחתיכ' עגמה יש ששים
דליכא למימר מלח ל
לטעמא עבודא וחעמ'
לא בטיל דהא לא שייך
אלא בדבר האיסור כ
כגון תבלין של עו' פ'ק
דחולין אבל מלח גושי
התר הוא: עוד הנה'
מאז' אי לא מסתפינא
מחכיריא אמונא מילת
הכי הכשר שנמלח ו

ושהה כשיער עליימו והוסס בקדירה בלא הדחה שהוא מותרת ש
שהחתיכה גושה ורוטב מבטלין אותו דם דכפיק מוכ מסוס דחתיכ'
שנמלחה פלטה כל הדם לחוץ וריא התורגמור ולא איסור אלף דם
שעליו לכך חתיכה גושה וכל מה שבקדוס מטורף לבטל האיסור בה
וכן כהגמיהם להתיר: ע' על תרי הגהו' אילנו מאז דאמאזו בבתרא
הצריך לנרף כל הה שבקדירה לבטל מה שאין כן בראשונה דחתיכה
ג' פא מבטלת בלתי שום טורף ויש לחלק בין חתיכה עבה דדמה
מרובה ומלחה מועט ובין חתיכה קלושה דמלחה מרובה ודמה מוע
עב': היינו שיעור מיל כרע' והרמבם וסמך לדבר במלח כגמט
מיל ושיעור מיל שליש שעה פחות חלק אחד והיינו דוקא לקדירה'
ואם לאו אף הקדירה אסור ואפי' אם הוסס רק בגלי תאשון שהוד
סלתו בו וכזו' יהיה אודם שהתחיל אלהכו יהודי נד בשטויהן מתין

Hb7(R)

בויניציאה גוליאלמו ליבי צרפתי 1547.
Est ce dans ces lettres, sous l'adieu de Magnifique (Mestre
Carlo Quirini, pour luy a les Mago de paraisa. et les maisons
au bout d'une telle regardant sur le pays de La Madona de Lucio

Transcription of the annotation

Ce petit texte suyvante est la 4e que jay taillee, et Ceste grosse glose est la 5e, q(ue) j'ay aussi taillee a Venise pour la predict Maggio ou Mazo, i(d est) May de Parense, cōme ap(er)t p(ar) mon nom au dessoubz, 1547'.

Ces deux lettres taillees soubz l'adveu du Magnifique Messer Carlo Quirinj, pour luy et les Mazo de parensa en une maison, size au bout dune ruelle regardant sur le quay de la Madona de lorto

Translation of the annotation

The following small text is the fourth which I cut and this large gloss is the fifth, which I also cut in Venice for the previously mentioned Maggio or Mazo, that is to say May de Parense (Meir di Parenso) as is shown by my name printed below

These two characters cut with the consent of the most excellent master Carlo Quirini, in a house situated at the end of a small street looking out of the quayside of Madonna dell'Orto.

Hebrew source:

Assembled text dealing with Halakhic rules of Kashrut and the salting of meat. Final line is Le Bé's imprint.

La petite glise de Soffouls est la .6.^e Autre d'entre
 Jay taillé a grande l'at p'uis l'ant^{re} de droite f'ainte a D'antse
 p'ome les May de p'uis l'ant^{re} de vno m'ic'ant Gambri
 que je trouue a l'usage a luy d'unt par m'ic'ant / ayant beau
 sur le Camp de St L'ieu a ceste de L'eglise 1548

este glise d'entre la p'etite Comp'agne
 le p'uy de la b'ille a le p'uy f'ont en Soffouls

6

רני אלעזר חומר

סכנה דכריס: בגולם וסכנה סכסס: חכס
 אינו מדבר לכי: מי גדול עתה סכסס
 וכו' וימי נכסס חתך דכרי סכסס ואינו
 נכסס: להשיב סוף חכסס סכסס חתך סוף
 כעין חכסס: סכסס: ואומר על סכסס ועל
 אחרון אחרון ועל סוף סוף אינו לא סוף
 מי חכסס: על סכסס חכסס: בגולם: סוף
 לאתק סוף: סכסס: חכסס: חכסס: חכסס
 כו' ויגידהו בוליאלמו לימי נרשע:

1548

Hb5(R)

Hb8(R)

Hb5(R)

BIBL. NAT.-655 N.A.F. 4528, f.5
 PARIS
 SERVICE PHOTOGRAPHIQUE
 REPRODUCTION INTERDITE

Transcription of the annotation

La petite glose cy dessoubz est la 6e lettre dont jay taillee et gravee les poinsons en acier, faicte a Venise pour ledit May de Parenza, en une [maison?] chambre que je tenoye a loyage a un ducat par moys/ayant veue sur le Camp de St.-Lio, a costé de l'église. 1548

Cette glose ditte la petite cursive; le nom de la ville et le mien sont au dessoubz

Translation of the annotation

The small gloss below is the sixth character for which I engraved and cut the punches in steel, made in Venice for Meir di Parenzo, in a room which I rented at one Ducat a month looking out on the Campo St Lio next to the church.

This gloss is called small cursive and the name of the city and my name are found below.

Hebrew source:

***Mishnah*, Tractate Avot, Chapter Heh (6)? Final line is Le Bé's imprint.**

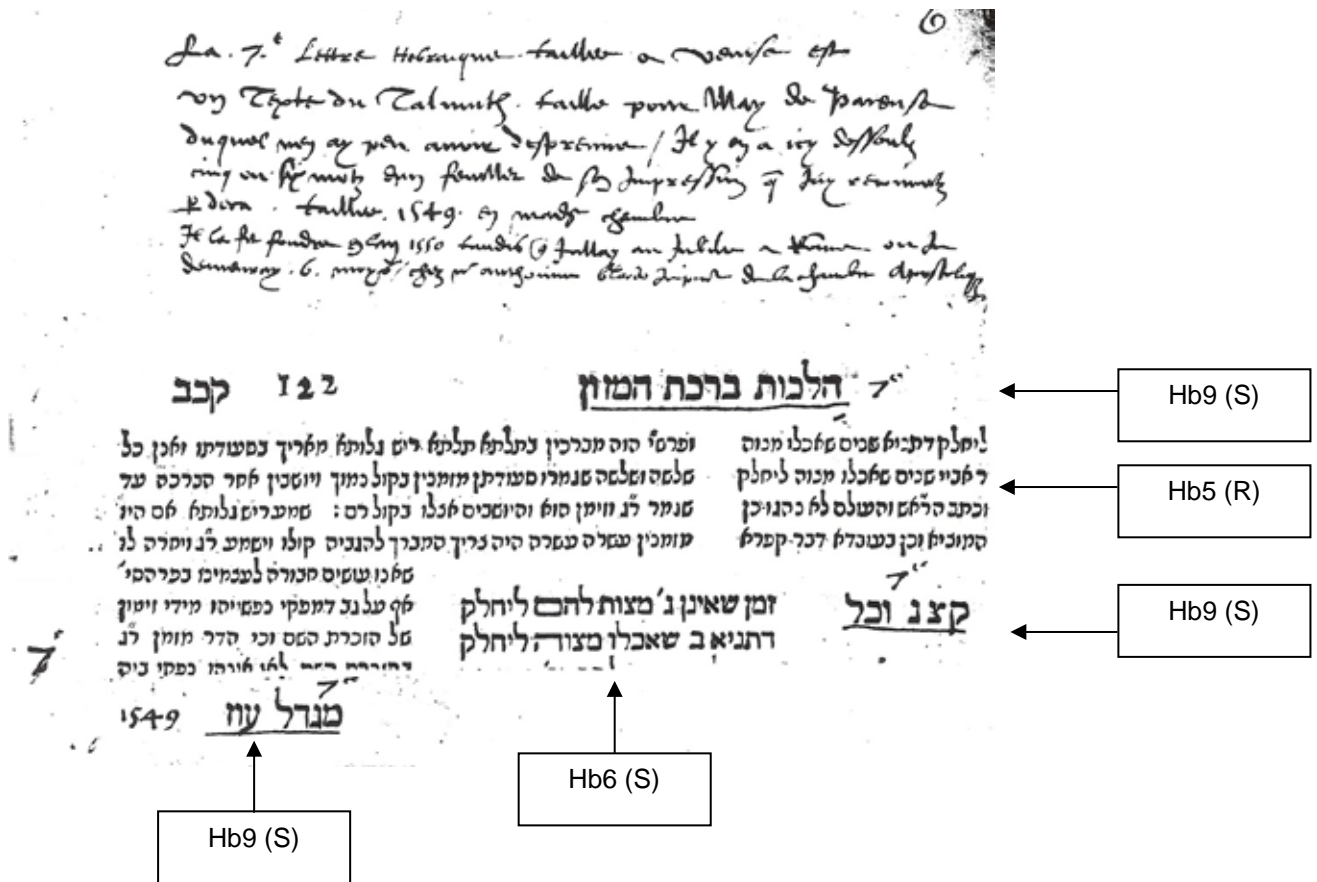

Transcription of the annotation

La 7e lettre Hebraique taillee a Venise est un Texte de Talmuth, taillee pour May de Parense, duquel nen ay peu avoir despreuves /Il y en a icy dessoubz cinq ou six motz dun feuillet de son impression, q(ue) j'ay recouvertz p(ar) deça. taillee, 1549, en maditte chambre.

Il la fit fondre en l'an 1550, tandis q(ue) jallay au Jubilee a Rōme, ou je demeuray 6 moys, chez M(onsieur) Anthoino Blade, imprimeur de la Chambre Apostolique.

Translation of the annotation

The seventh Hebrew character engraved in Venice is a Text for the Talmud, cut for Meir di Parenzo, for which there is no specimen. There are here below five or six words from a sheet printed by him (i.e. Meir di Parenzo) which I obtained from him [?]. Engraved in 1549 in my own chambers (workshop).

He had it cast in 1550 whilst I was away in Rome for the Papal Jubilee, where I stayed six months with Antonio Blado, printer to the Apostolic Chamber.)

Hebrew source:

A discussion of the Laws of the *Birkat Mazon* or the laws relating to the blessings and prayers recited before eating. The actual page consists of two specimens pasted down in the document, with the main body from *Sefer Orach Hayim* and a smaller bit containing the words *Migdal Oz* – a commentary on Maimonides by the thirteenth century Spanish Talmudist and cabalist Shem-Tov ben Avraham ibn Gaon.

8
 Cette lettre est une lettre primitive de Benjamin Petit Land
 et a été écrite pour moi le 1548 / 49 en l'année
 pour quand les lettres de Malte / on est en ce temps et taiten-ant
 La procédure de leur est...
 8"

יחי המלך

בְּאוֹר פְּנֵי מֶלֶךְ חַיִּים וְרִצּוֹנוֹ כְּעַב
 מִלְקוֹשׁ: חֶסֶד וְאַמֶּת יִצְרוּ מֶלֶךְ
 וְסֵעַד בְּחֶסֶד כְּסָאוֹ: מֶלֶךְ יִשְׁבַּע עַל
 כְּסֵא דִין מְזוּרָה בְּעֵינָיו כָּל רַע:
 פְּלִגֵּי מַיִם לֵב מֶלֶךְ בְּיַד יְהוָה עַל
 כָּל אֲשֶׁר יַחְפִּץ יִטְנוּ: יִרְא אֶת
 יְהוָה בְּנֵי וּמֶלֶךְ עִם שׁוֹנִימ אֵל
 תִּתְעַרְבּוּ: רִצּוֹן מַלְכִים שִׁפְתֵי
 צְדָק וּדְבַר יִשְׂרָאֵל יֵאָהֵב: חוֹיֵת
 אִישׁ מְדוּר בְּמִלְאֲכָתוֹ לִפְנֵי
 מַלְכִים יִתְיַצֵּב כָּל יִתְיַצֵּב לִפְנֵי
 חֲשָׁבִים: בּוֹיְנִיצִיָּא
 גּוֹלִיאֵלְמוֹ לִיבִי צִרְפְּתִי:

Hb10 (S)

1548. 49

BIBL. NAT. 655 U. L. F. 4528, f. 7
 SERVICE PHOTOGRAPHIQUE
 PARIS
 REPRODUCTION INTERDITE

Transcription of the annotation

8^e. Ceste lettre est une lettre nōmee en l'imprimerie Petit Canon, Taillee a Venise / Pour moy, en l'an 1548 / ou 49/ et justifiee quant et quant les lettres de Mazo /et a este ceste cy taillee avāt la precedente du texte d'un Talmuth p(ou)r ledit Mazo.

Translation of the annotation

8th. This character is a character called by printers Petit Canon [and] was cut in Venice by me in the year 15489 or 49, and justified by and by for the characters of Mazo, and was cut before the previous one [following the example?] on the text for the Talmud for the abovementioned Mazo.

Hebrew source:

Text composed of various verses from Proverbs 16 and 22. Final line is Le Bé's imprint.

Transcription of the annotation

L'an 1551, en esté ville de Paris, jay taille ceste lettre 9^e pour le s(ieur) Claude Garamond, taill(eu)r & graveur des lettres Grecques du Roy et ce apres mō(n) retour d'Italie et de Troye a Paris; taillee en sa maison, rue des Carmes
/†undeciphered text†

De ceste lettre ne sen est veu une belle ny bōne feuille imprimee, car laditte lettre estant bien fournie de lettres, Daguetz/ pointz et accents/ lettres cōmunes / Lettres Grandes, demy grandes et estroites pour faciliter la cōposition en la contraincte ès fins des lignes dautant q(ue les Hebr(eux) n'usent point de division et separatiō des motz en la fin de ligne / Les Imprime(u)rs ont indiferēment mesle lesdittes lettres en la besongne faisant servir a toutz rēcontres celles qui ne se doibvent mettre que en fin de lignes et m'enbrouliant et meslant le tout / Et est une lettre fort artiste^m faicte et bien limee et polie (sans vantise) et au cōtentemē(nt) de celuy q(ui) en sçavoit plus que moy.

A la vente de ses meubles le s(ieur) Christophe Plantain, en achepta les Matrices et les Mousles quil a portes a Envers et en a imprime la.

Et Andre Vechel en achepta les poinsons quil a transportes en Allemagne.

Et je en achepte une frappe de la vesve qui me presta les poinsons p(ou)r la fayre à mes despens avant q(ue) les vendre.

Translation of the annotation

In the summer of the year 1551 in the city of Paris, I engraved this ninth character for Monsieur Claude Garamond, cutter and engraver of Greek characters for the King, and this after my return from Italy and Troyes to Paris. This was done in his house in the rue des Carmes.

Of this character there is neither a beautiful nor good printed sheet, as this character is well provided with letters, dagesh points and accents, 'common' (i.e. normal width), large, extended and condensed letters to assist composition given the constraint of the ends of lines. Since the Jews do not divide words at the ends of lines, many printers have used these [additional] characters in an incorrect fashion for composition, using them in situations where they should not be placed except for ends of lines, thus adding confusion⁸⁷⁴ and mixing up the whole. And this is a character aesthetically made and well filed and polished (without boasting) and approved by those who understand more about it than me.

Upon the sale of his (Garamond?) household contents, Christophe Plantin bought the matrices and the moulds which he took to Antwerp to be used for his printing.

⁸⁷⁴ Omont transcribes this as 'm'enbrouliant', but it is more like that what Le Bé wrote was a variant of s'embrouiller, meaning mettre de la confusion, de l'obscurité. See <http://artfl-project.uchicago.edu/node/45> [Accessed 16 August 2011]

And André Wechel bought the punches which he took with him to Germany.

And I purchased a strike from his widow who loaned me the punches in order to make them before selling them on.

Hebrew source:

Musar HaSekhel (Ethics of Morality), thought to have been written by the tenth-century Jewish scholar and commentator Hai Ben Sherir Gaon of Pumbedita in modern Iraq (939 –1038).

L'ay 1569. Ay talle cime ce gros gros dulle. Cime Gabran
lequel ayme fait d'ours les premiers troubles de ay l'ordre les
prouisuns / La fraye des Mathurin / le Mouille / au for c'hy / huff
70 Comtoy / a buy mavege a cause des troubles

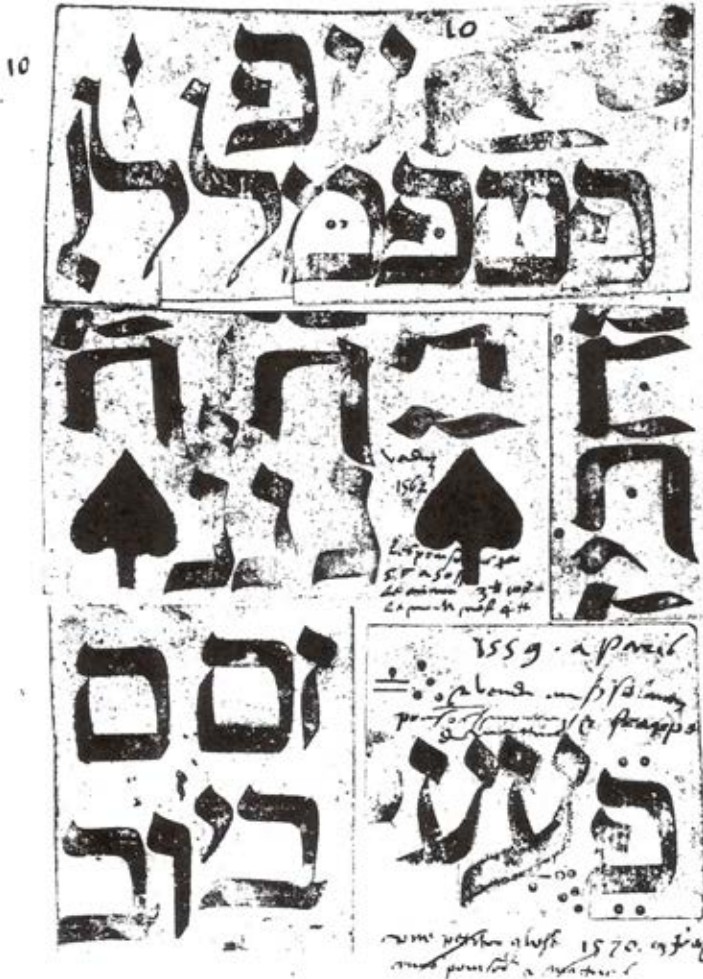

Transcription of the annotations

Lan 1559.⁸⁷⁵ Jay taille ceans ce gros duple canō(n) hebreu lequel estant faict durant les premiers troubles je ay vendu les poinsons/la frappe des Matrices/ et le Moule au s(ieur) Christoffe Plantain/ a bon marche a cause des troubles

Venduz 1562. – Les poinsons pour 5 escus à 50s. Le cuivre à 3 l. 10s. Le moule nef, 4 l.

1559 a Paris, et vendu au s(ieur) Plantain, poinsons. Moule et frappe de matrice.

Une petite glose 1570, cy je ay céans poinsons et matrices.

Translation of the annotations

In the year 1559 I engraved in this house (?) this large double Hebrew Canon which, being done during the first troubles, I sold the punches, the strikes and the mould to Christophe Plantin at a reduced price, due to the effects of the troubles.

Sold: 1562: The punches for 5 escus to 50 sous (?); the copper (i.e. strikes) at 3 livres 10 sous, the brand new mould at 4 livres.

1559 at Paris and sold to Monsieur Plantin, punches, mould and strikes of the matrices.

A small gloss (dated) 1570. I have the punches and matrices.⁸⁷⁶

Hebrew source:

Miscellaneous characters

⁸⁷⁵ The date 1562 was corrected by hand to 1559. See Omont, *Specimens de caractères hébreux, grecs, latins, et de musique gravés à Venise et à Paris par Guillaume le Bé, 1545-1592*, p. 11

⁸⁷⁶ This annotation appears to have added in error on this sheet, hence the two oblique deletion lines across the text. It relates to the specimen on f. 9v which follows.

13.
 La Falsification de l'acte pour faux tailleur est la petite
 gloze de desordres faicte en l'ay 1570 comme par
 ce qui est en l'acte de faux a' d'ouze

13

פירוק אבות

סכנה דברים כגולס ומכנס כחכם חכם
 אינו מדבר לפניו וזו פגדול וזונו כחכמי
 וזכרון וזינו כחכמי לזר דברי חכרו
 וזינו כחכמי להשיב שאל וזמיו פזונו
 וזמיו שזו כחכמי וזמיו כחכמי וזמיו
 על ראשו ראשו וזל חזרון חזרון ועל
 כל פזו חזרון כל פזו חזרון ועל
 פזו חזרון כחכמי :
 סכנה דברים כגולס ומכנס כחכם חכם
 אינו מדבר לפניו וזו פגדול וזונו כחכמי

Hb18 (R)

Hb16 (R)

REPRODUCTION INTERDITE
 SERVICE PHOTOGRAPHIQUE
 BIBL. NAT. 695 H.A.F. 41
 PARIS

Transcription of the annotation

La Treizieme ((13^e)) lettre que Jay taillee est la petite glose cy dessoubz faicte en Lan 1570, ceans pour moy, et en ay envoye une frappe a Venize.

Translation of the annotation

The 13th character that I engraved is this small gloss below, made in the year 1570, in this place for me, and of which a strike was sent to Venice.

***Note:* See the annotation on the previous folio (9) which relates to this specimen.**

Hebrew source:

***Mishnah* (Masekhet Avot, Chapter 4). Final line is Le Bé's imprint.**

Fay tailler a Paris dans les trois derniers jours de...
En papier de la ville de Paris de la fabrique de la ville de Paris...
Le papier de la ville de Paris de la fabrique de la ville de Paris...
 1566

ספר תהלים

12"

מכין הרים בחרו נאזר בנבירה : משביח שאון
 ימים שאון גליהם והמוז לאמים : וייראו ישבי
 קצורת מאותותיך מוצאי בקר וערב תרנין :
 פקדת הארצ ותשקקה רבת תעשונה פלג
 אלהים מלא מים תבין דגנם כי כן תכינה : 1566

11"

מוזן בעבור שהזכר הארץ הזכר ההרים בעבור שהם כמו עמודים וטעם
 נאזר בעבורה שגורמה גבורת השם ההרים הגבוהים שגור על כן נקראו
 הרוא ולפי דעתו שהזכר שהוא מכתם הדבר שאינו נראה וגבורתו נראית
 בעשות הגדולות : אשכית כמו תשכחם משקיט כדרך אתה מושל בנאות
 הים בעבור שהזכר וים רחוקים וטעם והמוז לאומים הגמולם למים כמו
 את מי הנהר העמומים והנה השם יוסיעם מהכבודת ומהגור : וייראו יושבי
 קצרות כנגד בית המקדש : מאותותיך והם גבורות המטר כמו עושה
 גדולות עד אין הקד וטעמו מוצאי בקר האותיות הנראות בבקר וכערב בעבור
 ירננו בני יודם והנה יהיה מלת תרנין יוצאה לשני פעולות ורבי משה אמר כי
 חמלת היום והלילה שסוף זה חמלת זה הם סבת הרננה : פקדת זה הכבוד
 לנאות על שנת כבודת היתה כבודת האויב לבא על בנין להביאה במבור
 והשם פקא ארצו שהיא ארץ ישראל ויש אומרים תשוקקיה כמו ותשקיה ואין
 זה נכון והעד ונפש שוקקה רק הוא כמו וירם תולעים ויבאש ונבר באש וככה
 רבים וכן הוא פקדת הארץ וכבר שוקקתה וכעבור זה הזכר פקדת :
 דניא ויוקיא גילנות פצית חוז לארץ ג'בא'א' גויס הלכה כאתר מגלח
 בפאריש גליאלמו' ל'בי' נרפתו עשה :

14"

1574

Cette copie finie dans le Fay 1574 et a 14" de haut
Soient que Fay tailler

BIBL. NAT. 655 N.A.F. 4528, f. 10
 SERVICE PHOTOGRAPHIQUE
 PARIS
 REPRODUCTION INTERDITE

Hb14 (S)

Hb13 (S)

Hb18 (R)

Transcription of the annotations

(Above) Jay taille a Paris p(ou)r moy ces trois lettres suyvantes, et premierement ce texte, grossi de la Bible in 4^{to} de Rob(ert) Estienne, est celuy duquel le s(ieu)r Plantain a imprime le texte de la grand Bible en cinq langues, du roy d'Espagne; est ma 11e. Et le canon duquel est l'intitulation est la 12e; faitz en lan 1566.

(Below) Ceste glose faicte ceans en lan 1574 est la 14e lettre hebraïque que Jay taillee.

Translation of the annotations

I cut in Paris the three following characters, and firstly this text, enlarged (?) from the Robert Estienne Quarto Bible, is the typeface in which Plantin printed his large Bible in five languages for the King of Spain. It is my eleventh typeface.

The Canon in which the titling is set is the twelfth, made in the year 1566.

This gloss made in my house in the year 1574 is the fourteenth Hebrew typeface which I engraved.

Hebrew source:

Psalms 65: 7-10. Final line is Le Bé's imprint.

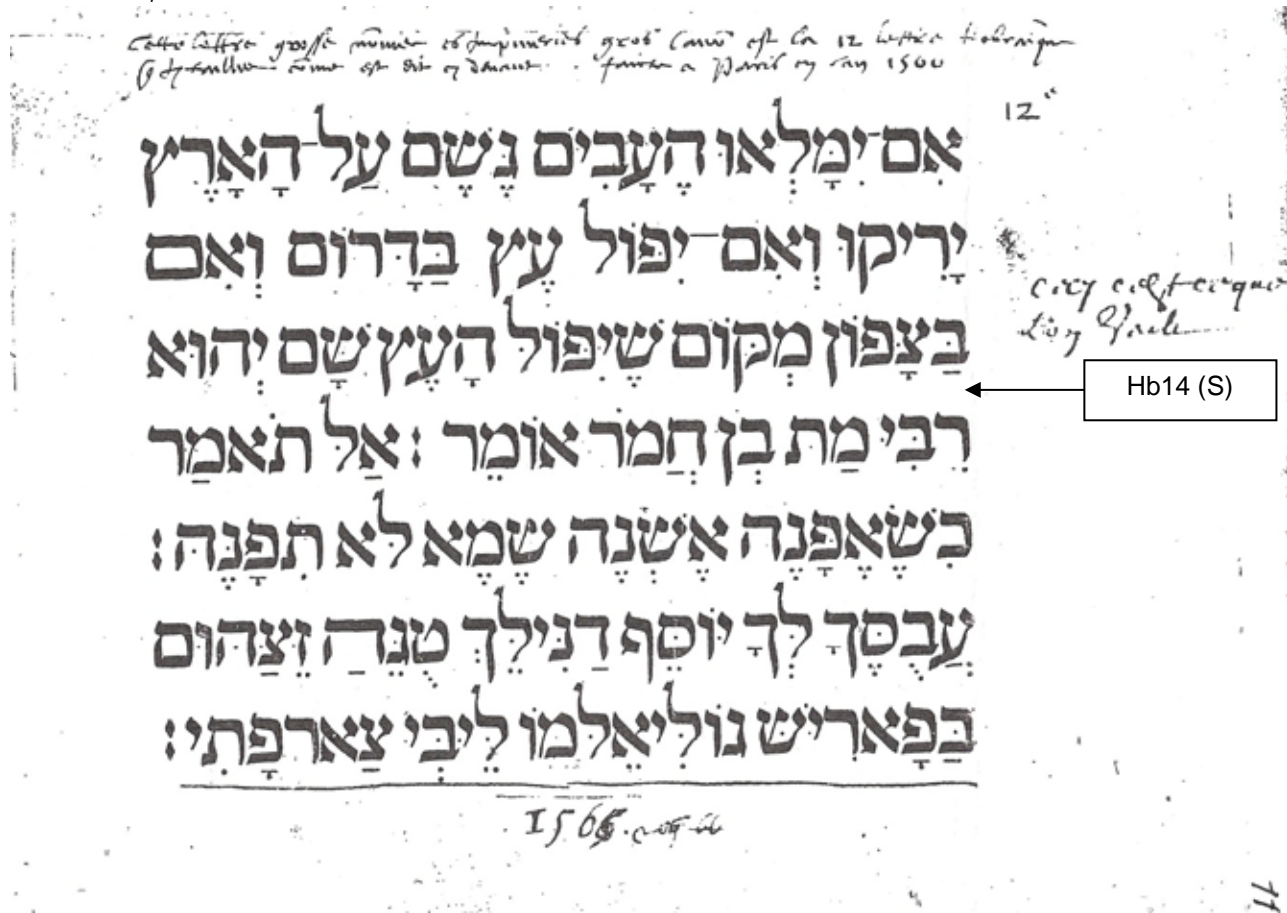

Transcription of the annotations:

Cette lettre grosse nōmee es imprimeries gros canō(n) est la 12e lettre hebr(aïque) q(ue) jay taillee, cōme est dit cy devant faicte a Paris en lan 1566.

Cecy est ce que l'on veult. (from a different hand)

Translation of the annotations

This large character called by printers large Canon is the twelfth Hebrew character which I engraved, and as is noted in the specimen was made in Paris in the year 1566.

This is what is wanted.

Hebrew source:

The first three lines are from Ecclesiastes 11:1. The fourth and fifth lines may be from the Mishnah, *Pirkei Avot* (Sayings of the Fathers) 2:5. Final line is Le Bé's imprint.

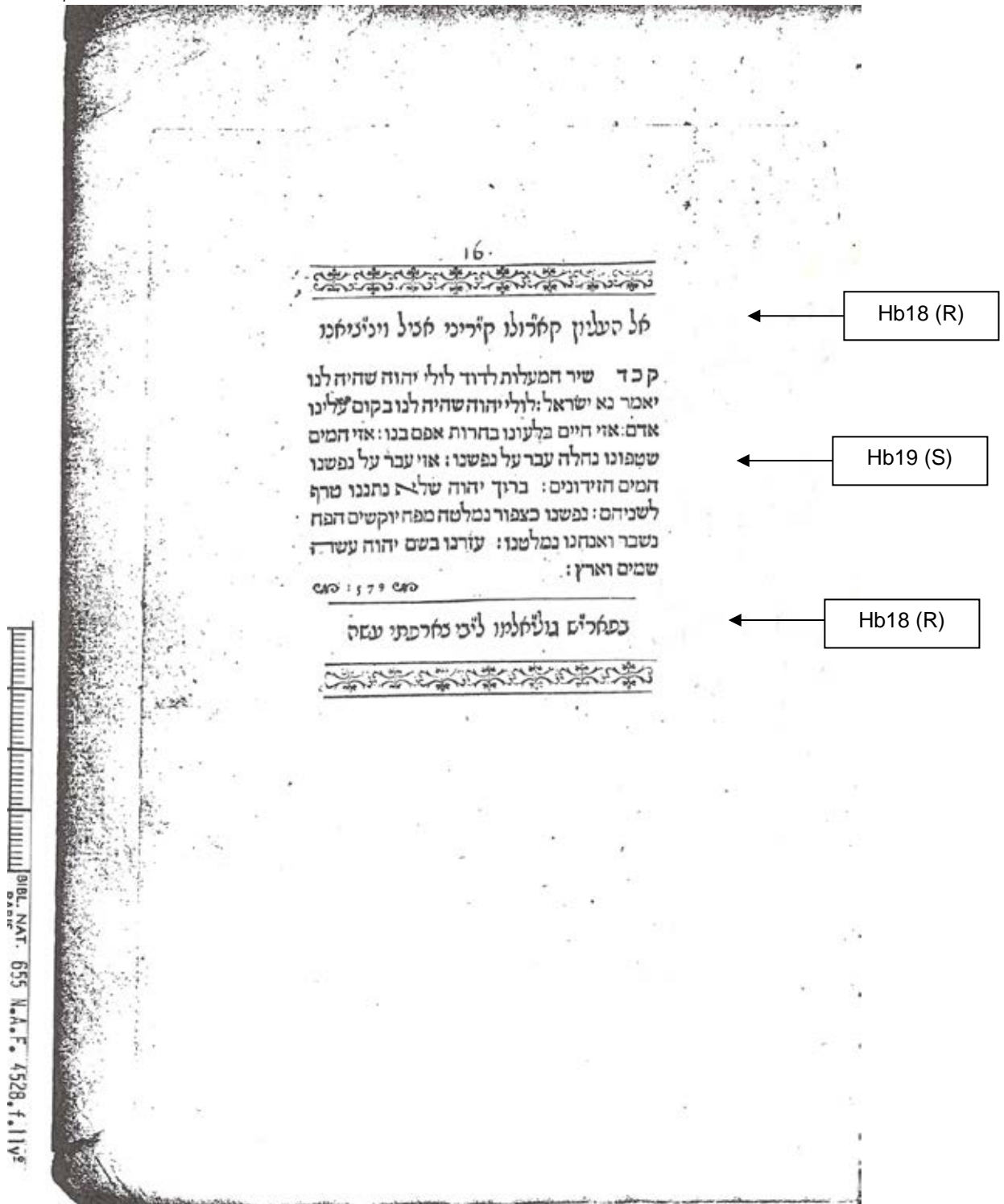

Hebrew source:
Psalms 124. Final line is Le Bé's imprint.

76
 L'ay 1569 et 70 par Marc Jay arseur de tailleur est
 un autre lettre Hebraïq par le Sr Christophle ploustain offiell
 est la. Quinziesme sorte de pousins de lettre Gubrayne
 de Jay tailleur et Hainmouit commande de la fuyre la plus petite
 que de pousins - se voy par exemple d'autre effray

15.

אברהם מאוניים בחלתך טמא את היכל קודש שמו
 את ירושלים לעיים: נתנו את כבלת עבודך מאכל לעוק
 השמים בשר חסידך לחירו ארץ: ששמו דמם בנים
 סביבות ירושלים אין קובר: דרייכו חרפה לשכנינו
 לענקים לסביבותנו: עד מה יהיה תאנה לצחח תבער
 במו אש קטנת: אא בגר הרחש יבד לטם
 בן ע ע פ א ק ר ש ת ר ת: חטור לאס:
 פשוטארהובסכתורחוראן קודך במאי נרוץ לנדלן
 רבאנתשת יקנכמווטרסטר: חטכשוניאקם ושם

A. Paris Par Guil. Iede. 1569 et 70
 en Mars.

Hb15 (S)

BIBL. NAF 55 N.A.F. 4528, f. 12
 PARIS
 SERVICE PHOTOGRAPHIQUE
 REPRODUCTION INTERDITE

Transcription of the annotation:

L'an 1569 et 70 en mars Jay acheve de tailler ceste petite lettre hebraique p(ou)r le s(ieu)r Christoffe Plantain laquelle est la Quinziesme sorte de poinsons de lettre hebraique q(ue) Jay taillee, et il m'avoit cōmande de la fayre la plus petite que je pourroye. Je n'en ay peu recouvrer dautre espreuve.

(By another hand) A Paris par Guil. Lebe 1569 & 70

Translation of the annotation

In the year 1569 or 70, in March, I completed the cutting of this small Hebrew character for Monsieur Christophe Plantin, which is the 15th type of punch of Hebrew letters which I have cut and he asked me to make it as small as I could. I was not able to obtain another specimen.

In Paris by Guillaume Le Bé 1569 & 70

Hebrew source:

Psalms 79:1-5 (A Psalm of Asaph)

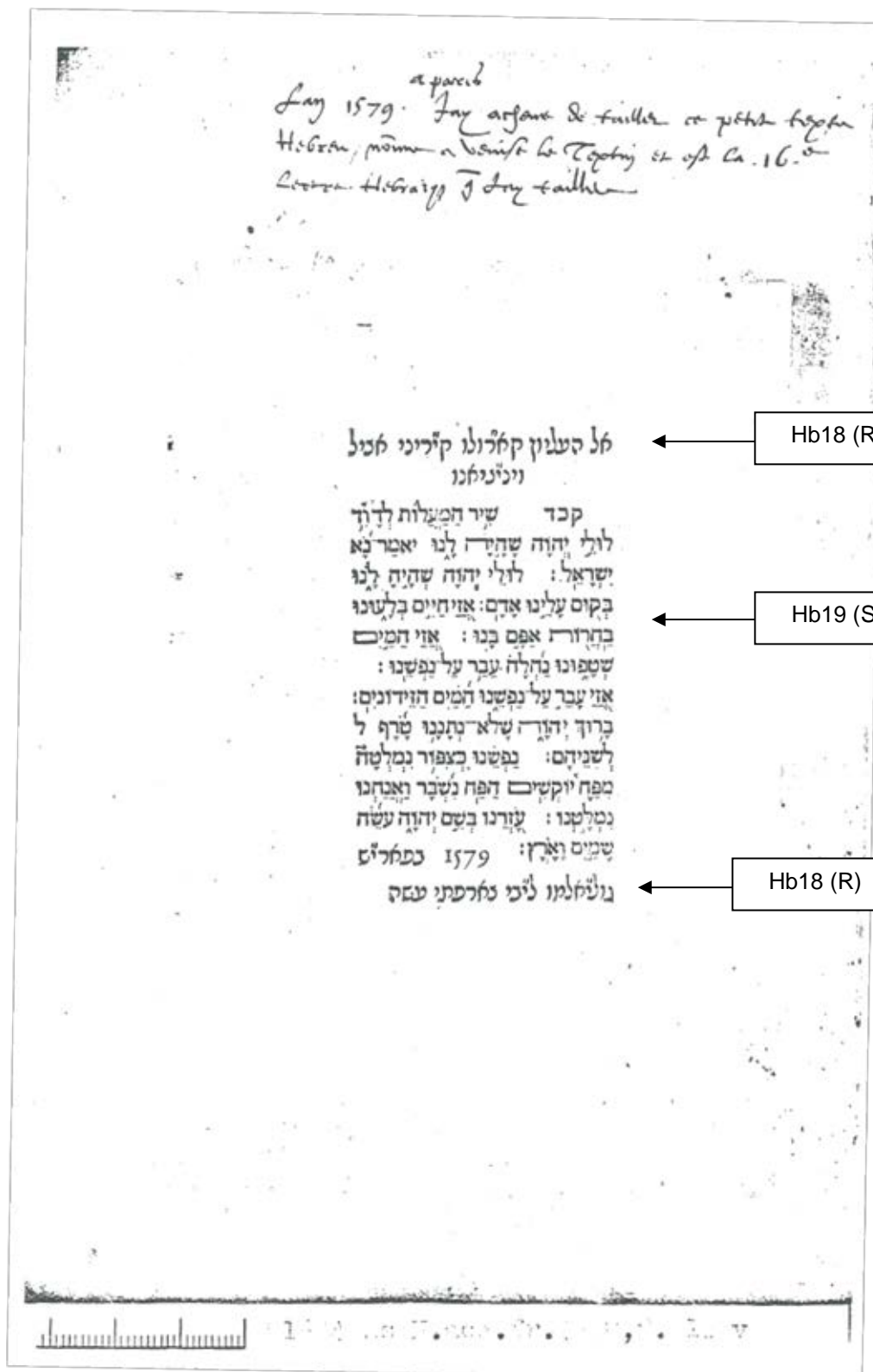

Transcription of the annotation:

Lan 1579 . Jay acheve de tailler ce petit texte hebreu, nōme a Venise le Textin, et est la 16e lettre hebraiqu(e) q(ue) Jay taillee.

Translation of the annotation

In the year 1579 in Paris. I completed the cutting of this small Hebrew text, called Textin in Venice, and which is the sixteenth Hebrew typeface which I cut.

Hebrew source:

Psalms 124. Final line is Le Bé's imprint.

L'any 1592 / en Juny a Juylliet Jay taulles une grosse
ghist-helvaugz qm est la 17^e festa de l'antre Sebrauz
Jay taulles toute a devises a Paris.
L'any se peut fonder par l'ordre sur la lettre de l'antre Sebrauz



זכריה

Hb14 (S)

וְהָיָה בַּיּוֹם הַהוּא לֹא יִהְיֶה אֹרֶךְ יָמִים
וְקִפְאוֹן וְהָיָה יוֹם אֶחָד הוּא יוֹדֵעַ
לִיהוּדָה לֹא יוֹם וְלֹא לַיְלָה וְהָיָה לַעֲתָ-
עֶרֶב יִהְיֶה אֹרֶךְ יָמִים

Hb13 (S)

וְהָיָה בַּיּוֹם הַהוּא בְּיוֹם שֶׁזָכַר שֶׁהָיָה בּוֹ הָאוֹת יִהְיֶה זֶה
הַעֲבִין שֶׁלֹּא יִהְיֶה אֹרֶךְ יָמִים וְקִפְאוֹן וְפִי' עַל דְּרֹךְ מִשְׁלַל
שֶׁלֹּא יִהְיֶה אֹרֶךְ הַיּוֹם הַהוּא בְּהִיר וְהוּא אֹרֶךְ יָמִים כְּמוֹ
וְיִרְחַק יִקְרָה הוֹלֵךְ וְלֹא אֹרֶךְ קִפְאוֹן וְהוּא קִפְאוֹן וְעַב שֶׁהוּא
כְּמוֹ חֲשָׁךְ וְפִי' שֶׁלֹּא יִהְיֶה הַיּוֹם הַהוּא כְּלוּ לֹא כְּאוֹר וְלֹא
כְּחֲשָׁךְ כְּלוּ' לֹא בְּרוּחָה וְלֹא בְּצַרָה כִּי שְׁתִּיהֶם יִהְיוּ בִּי וְכֵן
אֲמַר אַחֲרָיו וְלֹא יוֹם וְלֹא לַיְלָה וְיִתְּלֵא יִהְיֶה כְּהוֹרָא אֶהְיֶה
עֲדִי וּבְגִלְדִּי וְהָיָה יוֹם אֶחָד: אֹתוֹ הַיּוֹם יִהְיֶה יוֹם מִיּוֹחַד
לֵה' שִׁיּוּדֵעַ בְּבִצְרוּתוֹ וּבִפְלִאוֹתָיו שִׁיעֲשֶׂה בְּאוֹתוֹ
הַיּוֹם: לֹא יוֹם וְלֹא לַיְלָה: לֹא יִהְיֶה כְּלוּ יוֹם וְלֹא כְּלוּ לַיְלָה:
כְּלוּ' לֹא יִהְיֶה כְּלוּ צַרָה וְלֹא כְּלוּ רוּחָה וְהָיָה לַעֲתָ עֶרֶב
יִהְיֶה אֹרֶךְ יָמִים לַעֲתָ הַצַּרָה הַגְּדוּלָה שִׁיִּצְא הָעִיר בְּגוּלָה אִז
יִצֵּא ה' וְנִחַלְסָה בְּיוֹם הַהוּא:
בְּפִאֲרִישׁ גּוּלְיֵאלְמוֹ לִיבִי צְרַפְתִּי עֲשֵׂה' בְּחֹדֶשׁ נִסִּין בְּשַׁעַת
1592.

Hb22 (R)

Transcription of the annotation:

L'an 1592 /en Juin et Juillet, Jay taille une grosse glose hebraiq(ue) qui est la 17e sorte de lettre hebraiq(ue) que Jay taille, tant a Venise q(ue) a Paris, aagé de 68 ans, après le siège de Paris, pour passer l'ennui.

Laditte se peut fondre p(ou)r servir sur la lettre ditte le gros romain.

Translation of the annotation

In June or July of the year 1592, I engraved a large Hebrew gloss which is the seventeenth Hebrew typeface which I have engraved in Venice as well as in Paris. [It was done when] I was then 68 years old, after the siege of Paris, to overcome the boredom.

It may be cast to be used for the size called Gros Romain.

Hebrew source:

Zechariah 14:6-7. Final line is Le Bé's imprint.



Hb 17 (S)



Portrait & designe en lan 1573 & taillé en partie & le reste fait tailler p(ar) Machiel du Boys & austr. Sur le boys.

Drawn and carried out in the year 1573 and engraved in part (by myself) and the rest engraved by Machiel du Boys and others. On wood.

Hebrew source:
Hebrew alphabet



Hb 17 (S)

Hebrew source:
Hebrew alphabet

En Lan 1573 ^{aprez} Jay fait le deseing et portraict de l'alphabet Hebraique suyvant / en
 ensuyant les meilleurs traictz et les plus receuz de lantiquite au jugemen des plus
 experimentez es lettres Hebraiques p(ar) ceux de leur Religion et Nation / en la
 ville et cite de Venise ou Jay demeure Cinq ans et plus / suyvant les portraitz et
 brouillardz j'en fis lors q(ue) je y estoye.
 En ladite ville conversent plusieurs d'icelle nation ((judaique)), tant Italiens
 natifz q(ue) Allemagns, Hongrie q(ue) Orientaux de Pere en Constantinoble, de
 Salonic q(ue) autres lieux de la Turquie / tant rabbins q(ue) marchands, avec
 aulcuns a Romme aussi / en laquelle y en avoit lors peu sinon q(ue) de ceux qui
 trafiquent a la vente, friperie et usure.
 J'en ay taille une partie et le reste je lay fait tailler en boys p(ar) Machiel Du Boys,
 bien expert a observer le trait des lettres comme je les avoye portraites.

Transcription of the annotation:

En Lan 1573 Jay fait le deseing et portraict de l'alphabet Hebraique suyvant / en ensuyant les meilleurs traictz et les plus receuz de lantiquite au jugemen des plus experimentez es lettres Hebraiques p(ar) ceux de leur Religion et Nation / en la ville et cite de Venise ou Jay demeure Cinq ans et plus / suyvant les portraitz et brouillardz j'en fis lors q(ue) je y estoye.

En ladite ville conversent plusieurs d'icelle nation ((judaique)), tant Italiens natifz q(ue) Allemagns, Hongrie q(ue) Orientaux de Pere en Constantinoble, de Salonic q(ue) autres lieux de la Turquie / tant rabbins q(ue) marchands, avec aulcuns a Romme aussi / en laquelle y en avoit lors peu sinon q(ue) de ceux qui trafiquent a la vente, friperie et usure.

J'en ay taille une partie et le reste je lay fait tailler en boys p(ar) Machiel Du Boys, bien expert a observer le trait des lettres comme je les avoye portraites.

Translation of the annotation

In the year 1573 in Paris I undertook to design and draw the following Hebrew alphabet, by using the best and most acceptable forms from antiquity in the judgement of those most experienced in Hebrew letters of their nation and religion in the town and city of Venice, where I lived five years and more, and following the sketches and notes that I made when I was there.

In this town live many of this Jewish nation, some native Italians as well as Germans, Hungarian as well as Orientals from Pere (Galatia) in Constantinople, from Salonika as well as other places in Turkey, and as many Rabbis as merchants, with some from Rome, in which there had been few aside from those dealing in second hand goods, used clothes stalls and usury.

I engraved a part of the alphabet the rest was engraved in wood by Machiel du Bois, who was highly skilled in following the line of the letters as I had drawn them.

En l'an 1591 / apres le siege de la Ville de Paris durant les
 grandz troubles de par France a portraire ces deux lettres grosses
 Lune d'un texte et l'autre d'une glose qui est une lettre courante
 dont les Hebreux se servent en l'escripture de leurs comptes et affaires
 ordinaires / Ladite courante ou courante est un peu fardée
 suyvant celle de laquelle on imprime leurs cōmentaires ou gloses en leurs
 livres / suyvant celle des Orientaux Levantins au Espagnolz antiques
 mais celle qu'ils escrivent a la main n'est pas si fardée et arrondie
 mais sent plus sa chicanerie / coppie et courante

Ledit texte et glose ayant este mieus portraictz un peu
 comme la melancolie de luy le permettoit / ont este
 fort mal taillees par un qui n'a observe les traictz ny
 les corrections, n'ayant a cause du temps meilleur moyen
 de les fayre, se passerent aussi mal que le temps, et
 les despescha p(ou)r avoir de l'argent pour vivre. Je ne
 les ay point depuis fait raccoustrer, ayant la main trop
 pesante, aage de 67 a 68 ans.

Transcription of the annotation:

En lan 1591, apres le siege de la ville de Paris, durant les grandz troubles, je me suis amuse a portraire ces deux lettres grosses, Lune dun texte et lautre d'une glose qui est une lettre courante dont les Hebreux se servent en l'escripture de leurs comptes et affaires ordinaires /Ladite courive ou courante est un peu fardée suyvant celle de laquelle on imprime leurs cōmentaires ou gloses en leurs livres /suyvant celle des Orientaux Levantins au Espagnolz antiques mais celle qu'ils escrivent a la main n'est pas si fardée et arrondie mais sent plus sa chicanerie /coppie et courante.

Ledit texte et glose ayant este mieus portraictz un peu comme la melancolie du temps le permettoit /ont este fort mal taillees par un qui n'a observe les traictz ny les corrections, n'ayant a cause du temps meilleur moyen de les fayre, se passerent aussi mal que le temps, et les despescha p(ou)r avoir de l'argent pour vivre. Je ne les ay point depuis fait raccoustrer, ayant la main trop pesante, aage de 67 a 68 ans.

Translation of the annotation

In the year 1591, after the siege of Paris, during the great disturbances, I took pleasure in drawing these two large letters, one of a text and the other of a gloss which is the type of handwritten letter used by Jews for writing their accounts and for everyday business. This cursive or courante is not so 'painterly' i.e. calligraphic and rounded following the model with which they print their [biblical] commentaries or glosses in their books, and also from the model of the Oriental Jews or older Spanish. The script with which they write by hand is not so 'painterly' and rounded, but shows more its 'trickery', its flow and everyday origins.⁸⁷⁷

The text and gloss were better drawn, as much as the sad times would allow, and were very poorly engraved by someone who neither observed the flow of the lines nor the corrections, not having at the time any better ways of doing it and thus proceeded as badly as the time, dispatched them in order to obtain money to live. I have done nothing since to improve them due to my uncertain hands. Aged 67 to 68 years of age.

⁸⁷⁷ The meaning of this last sentence is difficult to understand. Le Bé does not appear to find the Jewish Courant hand very attractive and is perhaps trying to explain why he never used it as a model.

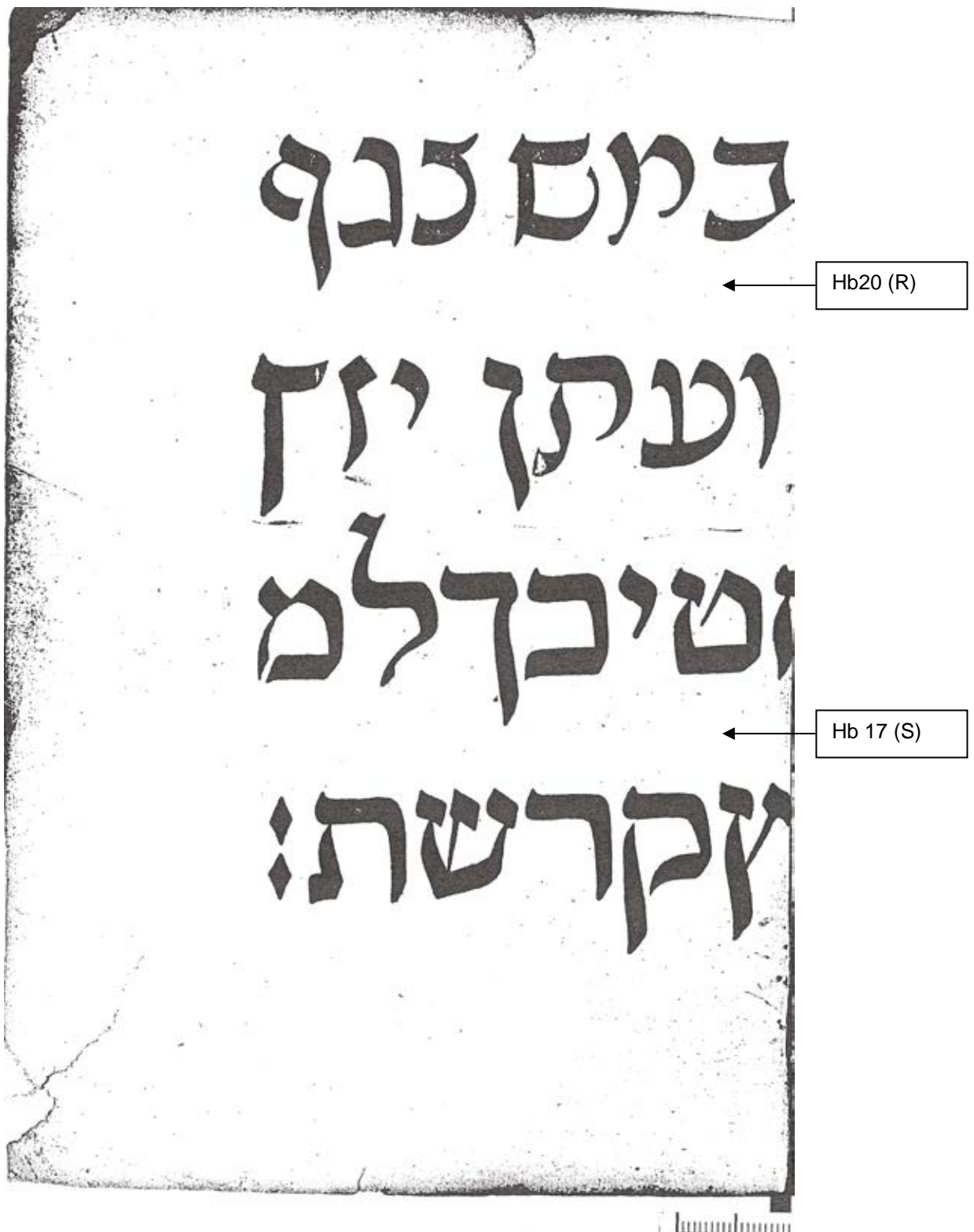

Hebrew source:
Hebrew alphabet



Hebrew source:
Hebrew alphabet

Εβραϊστικῶν ἡμῶν Ἐκκλησιαστικῶν ταύτην ἀνεῖλε
αὐτὸς τὸ 1548. ἦν ἡ Ἐκκλησιαστικὴ Ζαμὴτ. ἦν ἡ
ἀνεῖλε δὲ ἀνεῖλε. ἦν ἡ ἀνεῖλε ἡ ἀνεῖλε
ἡ ἀνεῖλε ἡ ἀνεῖλε ἡ ἀνεῖλε ἡ ἀνεῖλε ἡ ἀνεῖλε
ἀνεῖλε ἡ ἀνεῖλε ἡ ἀνεῖλε ἡ ἀνεῖλε ἡ ἀνεῖλε

I ἑωθινόν, ζ'. ἠχοῦ βαρύς.
δὲ σκοτεία καὶ πρῶι καὶ τὶ πρὸς τὸ μνη
μεῖον μαρτῖα ἐσηκας, πολὺ σκοτός ἔχου
σα ταῖς φρεσίν. ὑφ' ἧ πῆ τέθειται ζή
τεις ὁ ἴσ'. ἀλλ' ὄρα τὰς σωφρέχορτας μα
θητάς. πῶς τοῖς ὀφθορίοις καὶ τῶ σαρδα
ρίῳ, τὴν ἀμάσασιν ἐτεκμήρατο. καὶ ἀ
ρεμνήθησαν τῆς πόρι τὰς γραφῆς. με
θ' ὧν καὶ δι' ὧν. καὶ ἡμεῖς πικράσαστάν,
ἀνυμνῆμεν σε τὸν ζωοδότην χῆ ~

Gr2

Gr1

I γόρασι. κατασκλιώσαμτες εἰς ζωὴν
τὴν αἰώνιον. ὁ αὐτός: ~
ἀφ' οἰ τῶν ἀδελφοῦν τῶν, θησαυροῖ τῶν
ἰαμῶν. σωτήριοι τῶν πτωχῶν. ἀμαρ
τηρι παλάκλεις. τοῖς ἐν ἀμαρτίας
κεχέρορτας, ὁ δὲ ὠνωμένοι ἰάσατε.
ἰκετεύοντες θῆ τὸν ἀγαθόν, λυφώ
σαδαίμας τῶν παίδων τῶ ἐχθροῦ
δὲ ἄ. ἠχ' ἡ β. ἀμδρέου πυροῦ: ~
I αὐτὰ καὶ ἐπίφωτος, ἀμέτελε σήμε

III

BIBL. NAT. PARIS
SERVICE PHOTOGRAPHIQUE
REPRODUCTION INTERDITE
BIBL. NAT. 655 N.A.F. 4528, f. 18
SERVICE PHOTOGRAPHIQUE
REPRODUCTION INTERDITE

Transcription of the annotation:

Espreuve dun Grec Ecclesiastique, taille a Venice en lan 1548 pour Christoffe Zanetti, pour imprimer des alphabets, petites heures, qu'il nomme Horologi et aultres fatras et histoyres en grec vulgaires, pour apprendre les enfans a lyre.

Translation of the annotation

Specimen of an ecclesiastical Greek, engraved in Venice in the year 1548 for Christoforo Zanetti for printing alphabets, Books of Hours which are called Horologion⁸⁷⁸ and other trifles⁸⁷⁹ and stories in common Greek, which are used to teach children to read.⁸⁸⁰

Greek source:

Ὠρολόγιον/*Horologion* (Venice: Christophano Zanetti, 1546) ?

⁸⁷⁸ See Layton, *The sixteenth century Greek book in Italy: printers and publishers for the Greek world*, pp. 521-535

⁸⁷⁹ A fatra or fatras is an 'amas confus de choses frivoles et inutiles' (Féraud, *Dictionnaire critique de la langue française*, 1787-88. It may be a term of abuse or simply a term to describe a 'confused heape or bundle of trash, toys, trifles' etc as defined by Cotgrave in his 1611 dictionary. Vervliet translates it as 'trifle' in his 'Greek Printing Types of the Renaissance'.

⁸⁸⁰ A specimen of this Greek may be seen in the 1559 edition of Παρακλητική., printed by Cristoforo Zanetti in Venice. (BL 471d1). This was first noticed by Ellic Howe in his 1938 article on the Le Bé family. See Howe, '*The Le Bé Family*', p. 3

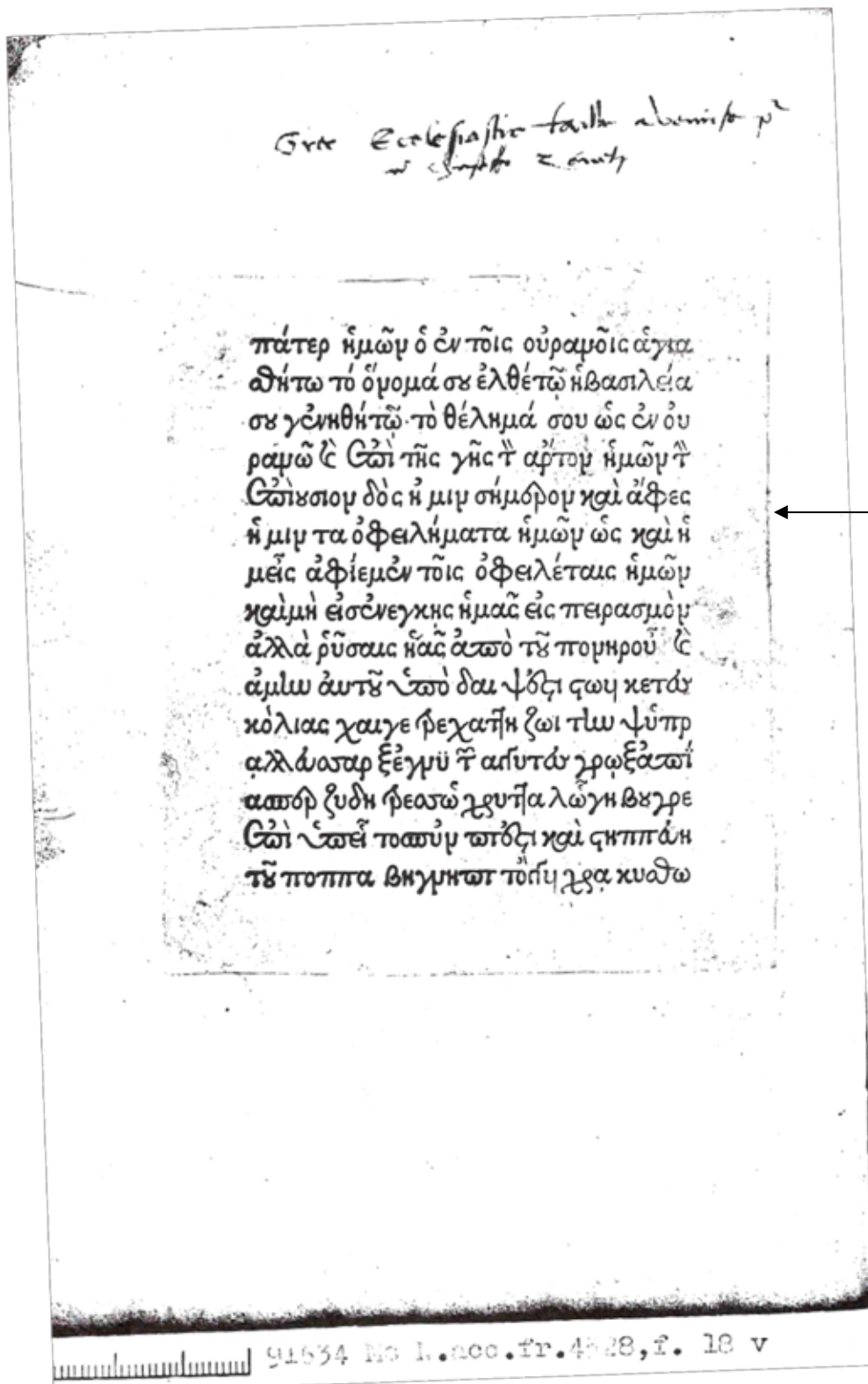

Grec ecclesiastique taille a Venise pour ce Christoffe Zanetti

πάτερ ἡμῶν ὁ ἐν τοῖς οὐρανοῖς ἀγα-
 θήτω τό ὄνομά σου ἐλθέτω ἡ βασιλεία
 σου γένηθῆτω τὸ θέλημά σου ὡς ἐν οὐ-
 ραῖς ἔστω τῆς γῆς ἡ ἀφ᾽ ἡμῶν ἡ
 ἁμαρτία δὲ ἡμῶν σήμερον καὶ ἀφε-
 ἡμῶν τα ὀφειλήματα ἡμῶν ὡς καὶ ἡ
 μῆς ἀφίεμεν τοῖς ὀφειλέταις ἡμῶν
 καὶ μὴ εἰσενεγκῆς ἡμᾶς εἰς πειρασμόν
 ἀλλὰ ῥῦσαις ἡμᾶς ἀπὸ τῆς πορνείας
 ἀμὴν ἀντὶ τῆς δαψύδος καὶ κενῆς
 κόλιας καὶ γεφύρας καὶ ζωντῆς ψυχῆς
 ἀλλὰ ἀσπασθῆναι τῆς ἀφ᾽ ἡμῶν
 ἀσπασθῆναι τῆς ἀφ᾽ ἡμῶν ἀσπασθῆναι
 τῆς ἀφ᾽ ἡμῶν ἀσπασθῆναι τῆς ἀφ᾽ ἡμῶν
 ἀσπασθῆναι τῆς ἀφ᾽ ἡμῶν ἀσπασθῆναι

Gr1

Transcription of the annotation:

Grec ecclesiastique taille a Venise pour ce Christoffe Zanetti.

Translation of the annotation

Ecclesiastical Greek cut in Venice for the same Christoforo Zanetti.

Greek source:

Ὁρολόγιον/*Horologion* (Venice: Christophano Zanetti, 1546) ?

Jay audit tems et an 1548 taille ces petites capitales latines et grecques pour moy et pour luy servir, dont je luy en fondis un peu, attendant q(ue) on luy en fait d'autres grecques gothesques (sic) Car ceste cy les simples en qui les nōment grec-latin, cōme ilz font aussi le grec qui sent sa plume courante.

ET ADORABVNT IN CONSPE
CTV EIVS VNIVERSE FAMILIÆ
GENTIVM QIA DIX ABCDEF
GHIKLMNOPQRSTVXYZ
Γ Δ Θ Ρ Σ Ξ Φ Ψ Ω

Rm1

Gr1

Transcription of the annotation:

Jay audit tems et an 1548, taille ces petites capitales latines et grecques pour moy et pour luy servir, dont je luy en fondis un peu, attendant q(ue) on luy en fait d'autres grecques gothesques (*sic*) Car ceste cy les simples en qui les nōment grec-latin, cōme ilz font aussi le grec qui sent sa plume courante.

Translation of the annotation

In the same time and year 1548 I engraved these Latin and Greek small caps for myself and for his use, of which I supplied him a small quantity, whilst waiting for him to obtain further Greek 'Grotesques' as these characters are called by some Greek/Latin, as the Romans have the flowing quality of the Greek.

Latin source:

Slightly garbled version of the Vulgate Latin text of Psalm 22:28 ? (reminiscentur et convertentur ad Dominum universi fines terrae et adorabunt in conspectu eius universae familiae gentium

*Je l'ai vu frapper a Florence a my Joseph Comenius de
 l'Esprit de l'homme
 et l'on a dit que a my Joseph Comenius
 et qu'il l'ait écrit un ouvrage de l'Esprit de l'homme
 de l'Esprit de l'homme
 de l'Esprit de l'homme de l'Esprit de l'homme de l'Esprit de l'homme
 de l'Esprit de l'homme de l'Esprit de l'homme de l'Esprit de l'homme
 de l'Esprit de l'homme de l'Esprit de l'homme de l'Esprit de l'homme*

1546/01.97 *Foy, fidei, in gressibus a dicitur, in gressibus a dicitur*

D. HIERONIMVS
 in ix. Hieremiae.
 Nec parentum nec, maiorum
 error, sequendus est: sed autho-
 ritas scripturarum, & Dei do-
 centis imperium.

91634 Ms N. acq. fr. 4528, f. 20

Rm 2

Transcription of the annotation:

1546/47 Jay tailler ce gros canō(n) a Venise, en ayant pour la plusp(art) este icy par Jehan Arnoul.

Je vendis une frappe a Florence M. Loreense Turentin, imprim(eu)r du Duc.

Et une a Venise a M. Tomaso Jontha.

Et depuis vendu encore une, envoye de Paris audit, estant la premiere bruslee avec son imprimerie.

Et pour veoir de limpression de ce gros canō(n) faut veoir le premier volume du *Consilia Doctorum*, imprime a Venise, duq(ue)l y en a une grande epistre imprimee toute de laditte lettre au cō(m)mencemen dudit livre.

Translation of the annotation

In the year 1546/47 I completed the engraving of this Large Canon in Venice, the majority of the punches having been completed by Jehan Arnoul (Le Picard). I sold a strike to Lorenzo Torrentino in Florence, the Ducal printer,⁸⁸¹ and another strike to Tomaso Jontha (Giunta) in Venice. And since that I sold another strike which was sent from Paris to the same Jontha being the first after the burning of his press.⁸⁸² And to see how this typeface looks when printed it is necessary to examine the first volume of the *Consilia Doctorum*, printed in Venice, in which there is a large letter entirely printed with this typeface at the beginning at the book.

Latin source:

From St Jerome's commentary on Jeremiah I:12?

⁸⁸¹ This type can be seen in Torrentino's 1549 edition *Rettorica et Poetica d'Aristotile* (BL 519d17) and in the 1551 edition of *Aristotelis de Anima* (BL 527m2). For further discussion see *ibid.*, pp. 3-5

⁸⁸² Tommaso and Giovanni were the sons and successors of the printer Lucantonio Giunta and active in Venice from 1538 to 1566. They signed themselves 'apud Junta' hence the form Le Bé used 'Jontha'. Their firm went bankrupt in 1553 and was burned down in 1557. It is this event to which to which Le Bé is probably referring. I am grateful to Hendrik Vervliet for drawing my attention to this point. See Ascarelli and Menato, *La tipografia del '500 in Italia*, p. 329. For more detailed discussion of the Giunti family, see Nuovo, *The Book Trade in the Italian Renaissance*, pp. 51-70

NAF 4528, folio 21v and 22
 Reduced from original: 75 per cent

The image shows a page from a handwritten musical manuscript. At the top, there is a handwritten note in French: "J'ay fait et taille ceste Musique grosse, en lan 1555, p(ou)r M. Adrian le Roy et Robert Ballard, imprimeurs du Roy en musique. Il n'y avoit q(ue) ceci de taille quand ceste esprouve fut faite, et faut veoir des Messes d'Orlande esquelles y a de telles sortes. - 1554 et 55". Below this, the name "Mouton." is printed. The main part of the page consists of several staves of music. A large, ornate initial 'R' is on the left side, decorated with floral and scrollwork patterns. The text of the song is written below the staves: "N venant de Lyon, & bō bō bō, trouuay en vn buisson Robin & Marion, qui lui leuoit son pelisson, et bō dnn". There are three annotations with arrows: "Rm 4" points to the initial 'R', "Rm 3" points to the end of the first line of text, and "Ms 1" points to the beginning of the second line of music. At the bottom of the page, there is another handwritten note: "J'ay mis en ceste page de taille, quand ceste esprouve fut faite, et faut veoir des Messes d'Orlande esquelles y a de telles sortes. - 1554 et 55".

Transcription of the annotation:

J'ay fait et taille ceste Musique grosse, en lan 1555, p(ou)r M. Adrian le Roy et Robert Ballard, imprimeurs du Roy en musique. Il n'y avoit q(ue) ceci de taille quand ceste esprouve fut faite, et faut veoir des Messes d'Orlande esquelles y a de telles sortes. - 1554 et 55

1554 et 55

Translation of the annotation

I made and engraved this large music in the year 1555 for Adrian Le Roy and Robert Ballard, printers for the King in music. There was only this type cast when this specimen was printed and it is necessary to see the masses composed by Orlande de Lassus where there are such types.

Music source:

Unknown edition of the Jean Mouton Chanson *En Venant de Lyon*

Ms 2

Sois moy Seigneur ma garde & mon appuy, Car en toy git toute mon esperance. Sus donc
aussi, o mon ame di luy, Seigneur, tu as sur moy toute puissance: Et toutes fois point ny
a demeure mienne, Dont iusqua toy quelque profit remienne. Mon vouloir est daider ap
ertueux, Qui de bien vivre ont aquis les louanges: Quemal sur mal puisse aduenir.

It 1

Music source:

Very likely a setting of Huguenot Psalm 16 from the *Octante-deux Pseaumes de David, traduitz en rythme francois par Cl. Marot et autres, avec plusieurs cantiques nouvellement composés en musique à quatre parties par M. Clément Janequin*. Paris, Adrien Leroy et Robert Ballard, 4 vol in-8° obl. 1559.⁸⁸³

⁸⁸³ Emmanuel Douen and Clément Marot, *Clément Marot et le Psautier Huguenot, étude historique, littéraire, musicale et bibliographique, contenant les mélodies primitives des Psaumes et des spécimens d'harmonie, etc* (Paris: L'Imprimerie Nationale, 1878), p. 518

NAF 4528, folio 23v-24
(reduced 70 per cent from original)

The image shows a manuscript page with six staves of musical notation. The text is written in a Gothic script. Annotations include:

- A box labeled "Rm 5" with an arrow pointing to the beginning of the first staff.
- A box labeled "Rm 4" with an arrow pointing to the end of the first staff.
- A box labeled "Ms 1" with an arrow pointing to the end of the fifth staff.

The text on the page is:

Audeamus omnes in dominu- diem festum celedran tes.fun
sub honore Marię Virginis decuius solennitate gaudent angeli & collau
dent filium Dei. Eructauit, &c.

Music source:

An unknown edition of a setting of the Catholic Ecclesiastical chant *Gaudeamus omnes* etc.

A page of handwritten musical notation on ten staves. The notation is in a medieval style, featuring square neumes on a four-line red staff. The lyrics are written in a Gothic script below the staves. The text is a Latin prayer or hymn. There are some ink stains on the page, notably a large dark smudge in the middle of the fifth staff.

*Et prope dicitur quod in Calcedonia Synodo prope dicitur in libro
prope dicitur in libro prope dicitur in libro prope dicitur in libro*

Ms 3

Transcription of the annotation:

**Pour lesdits s(ieurs) Adrien Le Roy et Robert Ballard. Espreuve d'une grosse
Tablulature despinette pour imprimer a deux foys pour en fayre un essay, fait en lan
15...**

Translation of the annotation

**For Adrien Le Roy and Robert Ballard. Specimen of a large Tablature for Virginal to
be printed twice, a trial setting. Dated 15??**

Music source:

**An unknown edition of a setting for tablature for Virginal. Most likely printed by
Ballard.**

*Specimen cum petra tabularum de prima fin la
moyens musique romaine ay 1559
70^e petra de a nob. Barland*

Ms 4

Transcription of the annotation:

Espreuve dune petite tablature d'espinnette sur la moyenne musique, commence en lan 1559, P(our) m(onsieur) Le Roy et Robert Ballard

Translation of the annotation

Specimen of a small tablature for virginal on the moyenne body, begun in the year 1559 for Monsieur Le Roy and Robert Ballard.

Music source:

An unknown edition of a setting for tablature for Virginal. Most likely printed by Ballard.

T A B L A T U R E.

4

Ms 5

BIBL. NAT. 655 N.A.F. 4528, f. 26v^o
SERVICE PHOTOGRAPHIQUE

The image shows a page of musical notation for a virginal. The title 'T A B L A T U R E.' is printed at the top. Below it, the number '4' is centered. The main part of the page contains two staves of music. The upper staff is a tablature staff with a treble clef and a key signature of one flat (B-flat). The lower staff is a standard musical staff with a bass clef and a key signature of one flat. The music consists of several measures of notes and rests. A circular library stamp is located in the center of the page, overlapping both staves. The stamp contains the text 'BIBL. NAT. 655 N.A.F. 4528, f. 26v^o' and 'SERVICE PHOTOGRAPHIQUE'. On the right side of the page, there is a box containing the text 'Ms 5' with an arrow pointing to the right edge of the page. At the bottom right, there is a vertical line of text: 'BIBL. NAT. 655 N.A.F. 4528, f. 26v^o' and 'SERVICE PHOTOGRAPHIQUE'.

Music source:

An unknown edition of a setting for tablature for Virginal. Most likely printed by Ballard.

D'ESPINETTE.

Ms 5

BIBL. NAT. 555 N.A.F. 4528, f. 26
SERVICE PHOTOGRAPHIQUE
PARIS
REPRODUCTION INTERDITE

Music source:

An unknown edition of a setting for tablature for Virginal. Most likely printed by Ballard.

Appendix D: Facsimiles, Transcriptions and Translations of the Le Bé document Rés X 1665

This appendix contains a complete page by page facsimile of the Le Bé Document Rés X 1665, together with a transcription of the annotations and a translation. The transcriptions are based on the two Omont articles of 1887 and 1889, but modified to make them more consistent with the actual spelling and style of the original.⁸⁸⁴ The transcription symbols used are a conflation of the 'Leiden' and 'Scriptorium' systems. Some symbols used by Le Bé are not available, such as the Renaissance 'et' sign, and other symbols have been substituted.⁸⁸⁵

(xxx) = expanded abbreviations

<xxx> = textual omissions

((xxx)) = Textual interpolation

†xxx† = Problematical reading

[xxx] = cancellations

[[xxx]] = Accidental loss

/ line or paragraph break used by Le Bé – probably used in place of comma (virgule)

These facsimiles are reproduced with the kind permission of the Bibliothèque nationale de France.⁸⁸⁶

⁸⁸⁴ Omont, *Specimens de caractères hébreux gravés à Venise et à Paris par Guillaume Le Bé, 1546-1574*, Omont, *Specimens de caractères hébreux, grecs, latins, et de musique gravés à Venise et à Paris par Guillaume le Bé, 1545-1592*.

⁸⁸⁵ Brown, *A guide to western historical scripts from antiquity to 1600*, pp. 5-7

⁸⁸⁶ Email dated 28 December 2011 12:50 from M. Philippe Bretagnon, Pôle redevance, Département de la reproduction, Bibliothèque nationale de France.

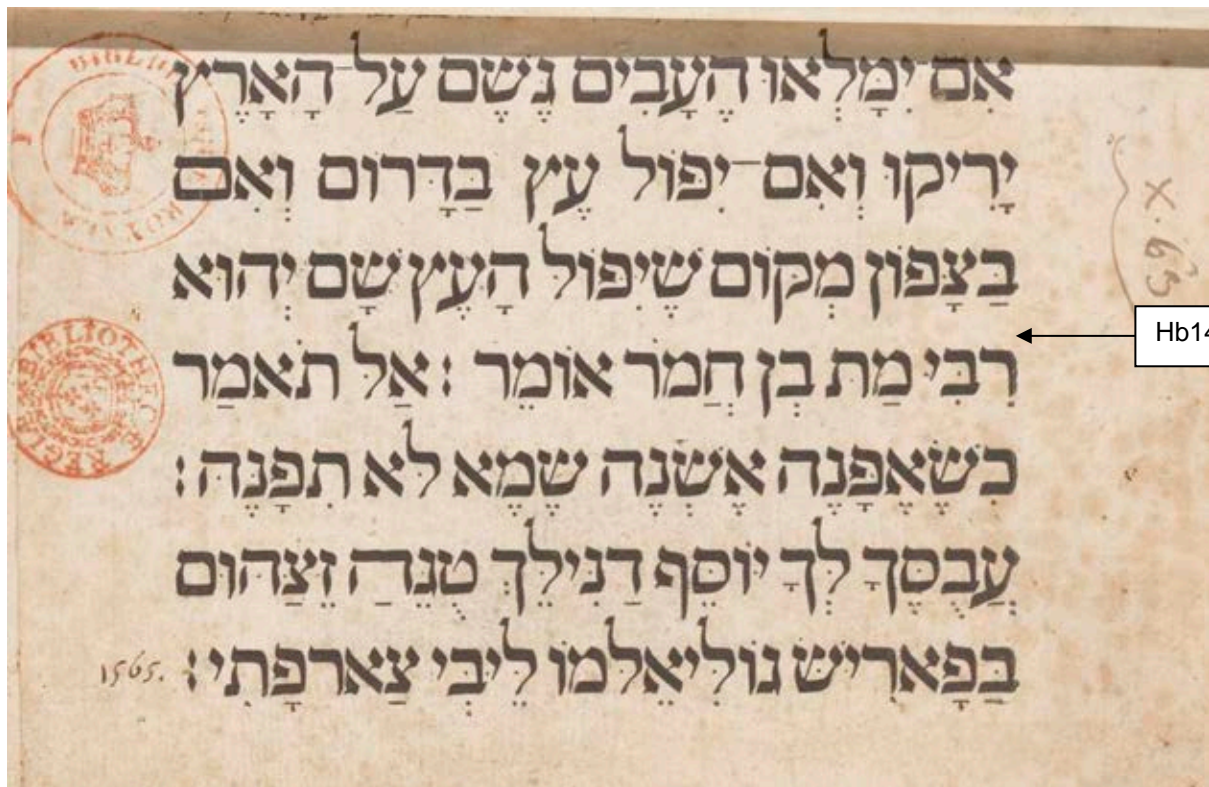

Transcription of the annotation

Ce Canon ou grosse lettre est de mon ouvrage, fait à Paris, en lan 1565, et est la 12^e des lettres de ma fasson. (Note: This annotation is placed in the fold of the document and thus not easily visible to the viewer).

Translation of the annotation

This canon or large character is my own work, made in Paris in the year 1565 and is the twelfth of the characters which I have produced.

Hebrew source:

The first three lines are from Ecclesiastes 11:1. The fourth and fifth lines are from the Mishnah, *Pirkei Avot* (Sayings of the Fathers) 2:5. Final line is Le Bé's imprint.

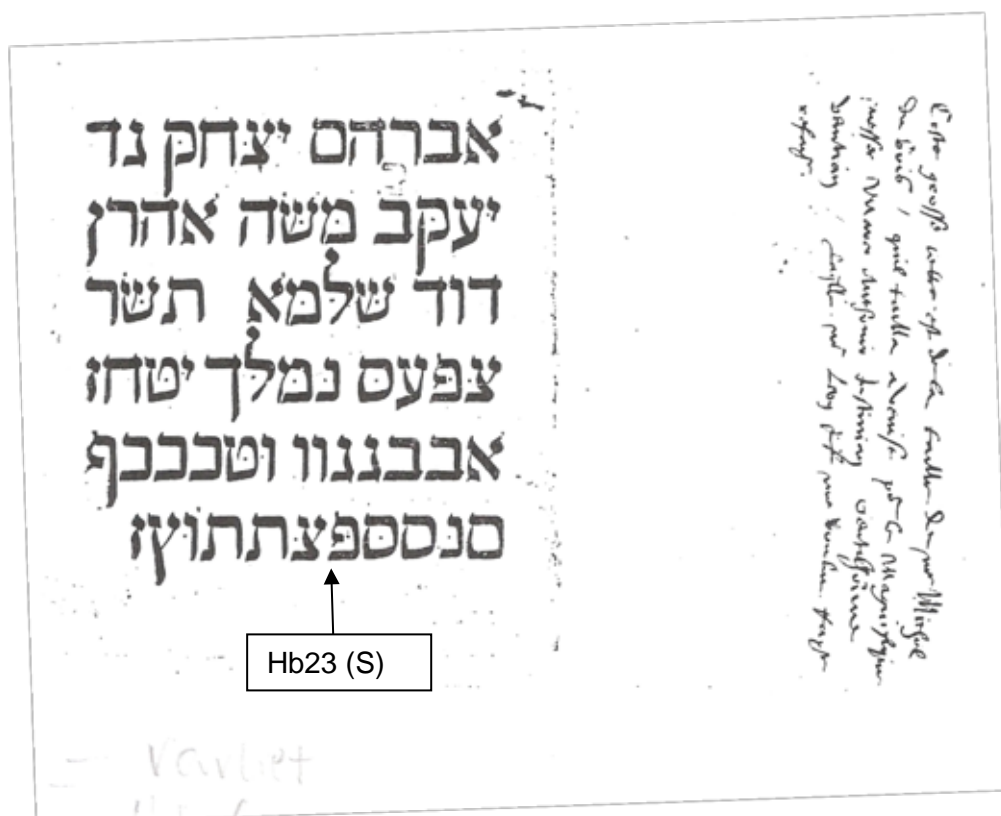

Transcription of the annotation

Ce grosse lettre est de la taille de m(esser) Michel du bois/ quil tailla a Venise p(our) le magnifique messer Marco Antonio Justinian gentihomme venetien/laquelle m(esser) Leon juif me voulut fayre refayre.

Translation of the annotation

This large letter was cut by Michel du Bois, who made it in Venice for the most exalted master Marc'Antonio Giustiniani, Venetian gentleman, and which the Jew Master Leon asked me to recut.

Hebrew source:

A conflation of Biblical names followed by four nonsense words, and finally two lines of characters in a semblance of alphabetical order.

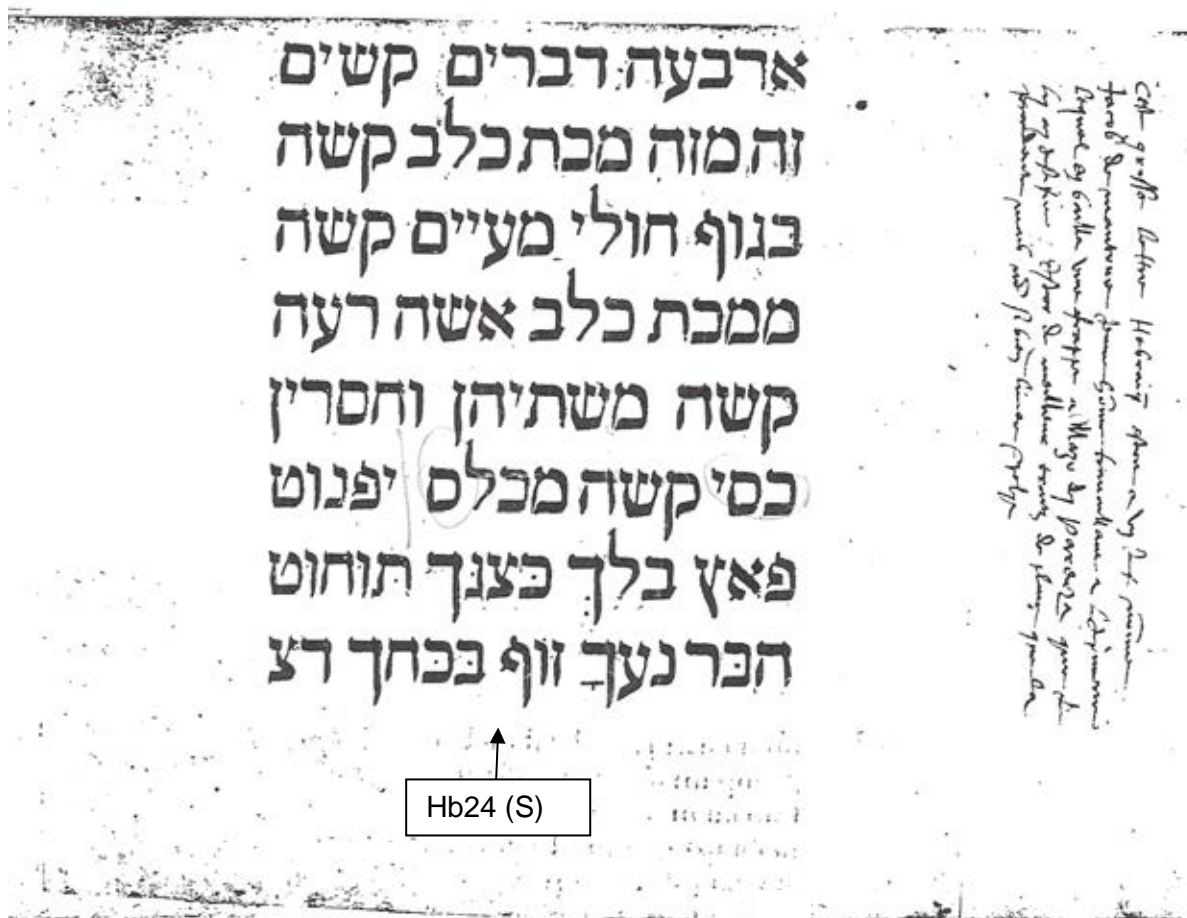

Hb24 (S)

86772 Rés X 1665, f.2

Transcription of the annotation

Ceste grosse lettre hebraiq[ue] estoit a un juif, nōme Jacob de mantoue, jeune homme travaillant a l'imprimerie, lequel en bailla une frappe a Mazo dei Parenza, que je luy ay justifie estre de meilleur traitz de plume que la precedente, mais non si bien limee et polye.

Translation of the annotation

This large Hebrew character belonged to a Jew named Jacob of Mantova, a young man who worked in printing, and who sold a set of strikes to Mazo di Parenzo, for whom I justified the matrices to be of a better hand than the previous ones, but not as well filed and polished.

Hebrew source:

A mixture of possible Talmudic text with errors and invented words to demonstrate the final characters

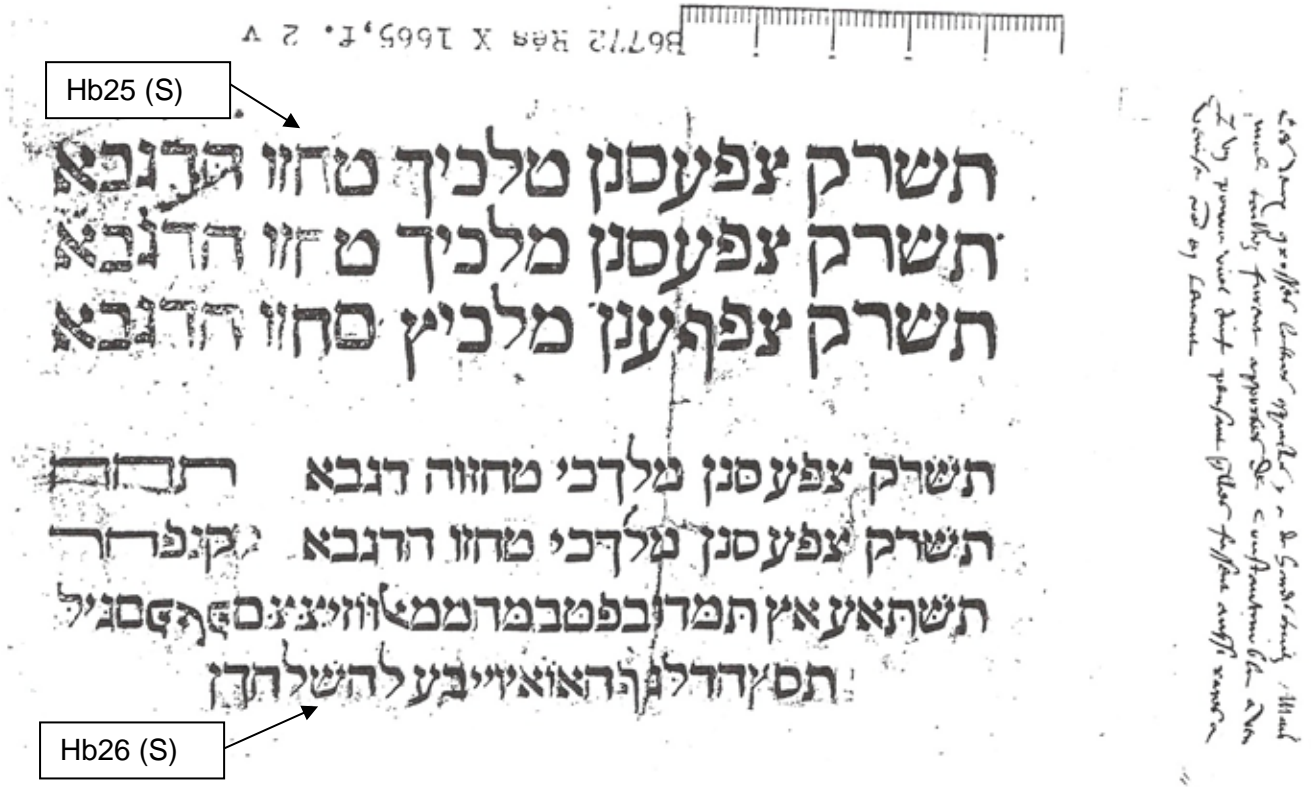

Transcription of the annotation

Ces deux grosses lettres, esquelles y a de hardis traitz, mais mal taillez, furent apportees de Constantinoble a Venise par un povre vieil Juif, pensant qu'elles fussent aussi rares a Venise comme en Levant.

Translation of the annotation

These two large characters, which have bold qualities but are poorly cut, were brought from Constantinople to Venice by a poor old Jew, who thought that they might be as rare in Venice as they were in the Levant.

Hebrew source:

A mixture of possible Talmudic text with errors and garbled characters to demonstrate the final characters

יחי המלך
 באור פני מלך חיימ ורצונו כעב
 מלקוש: חסד ואמת יצרו מלך
 וסעד בחסד כסאו מלך ישב על
 כסא דין מזרה בעיניו כל רע:
 פלגי מים לב מלך ביד יהוה על
 כל אשר יחפץ יטנו: ירא את
 יהוה בני ומלך עם שונים אל
 תתערב: רצון מלכים שפתי
 צדק ודבר ישרים יאהב: חזית
 איש מדור במלאכתו לפני
 מלכים יתיצב בל יתיצב לפני
 חשבים: כויניציאה
 גוליאלמו ליבי צרפתי:

Hb10 (S)

91633 Rés X 1665, f. 3

Transcription of the annotation

Ceste grosse lettre est de ma fasson, faicte a Venise, en lan 1548, sur l'eschantillon de la precedente, taille pour moy; et celui a qui je laissay mesdits poinsons en garde en a fait des frappes et tout mange, ayant vendue et poinsons et matrice a un Allemant ainsy que de Dansi m'ont mande.

Translation of the annotation

This large character is of my making made in Venice in the year 1548 on the basis of the previous character and cut by me. The person in whose care I had left my punches made matrices from them and stole everything, having sold the punches and matrices to a German from Danzig who sent me the specimen (?).

Hebrew source:

Text composed of various verses from Proverbs 16 and 22. Final line is Le Bé's imprint.

Ces cinq espreuves sont des lettres de [[Robert Estienne]]..... Les textes taillez a Paris en lan, 1541, par un nō(m)me Jehan Arnoul, dit le Picard, le jeune; et la glose taillee par aultre, bien pollie et bien achevee, sentant sa plume.

לְדוֹד בְּשָׁנוֹתָו אֶת־טַעְמוֹ לְפָנַי
אֲבִימֶלֶךְ וַיְגַרְשֵׁהוּ וַיִּלְךְ

Hb27 (S)

אֲבָרְכָה אֶת־יְהוָה בְּכָל־עֵת תָּמִיד תְּהִלָּתוֹ בְּפִי :
בִּיהוָה תִּתְהַלֵּל נַפְשִׁי יִשְׁמְעוּ עֲנוּיִם וַיִּשְׁמְחוּ :
גִּדְלוּ לַיהוָה אֹתִי וּגְדוּמָמָה שְׁמוֹ יַחְדָּו :
דַּרְשֵׁתִי אֶת־יְהוָה וְעַנְנִי וּמִכָּל־מְגוּרֹתַי הַצִּילֵנִי :
הִבִּיטוּ אֵלָיו וְגִהְרוּ וּפְנִיָהֶם אֶל־יַחְפְּרוּ :
זֶה עֲנִי קְרָא וַיְהוֶה שָׁמַע וּמִכָּל־צְרוּתָיו הוֹשִׁיעֵנו :

Hb28 (S)

Hb29 (S)

הִנֵּה מִלֹּאד־יְהוָה סָבִיב לִירְאָיו וַיִּחְלַצֵם : טַעְמוֹ וּרְאוּ כִי־טוֹב יְהוָה
אֲשֶׁר־יִהְיֶה יַחְסֶה־בוֹ : יִרְאוּ אֶת־יְהוָה קִדְשׁוֹ כִּי־אֵין מַחְסוֹר
לִירְאָיו : כְּפִירִים רָשׁוּ וְרַעְבּוּ וְדָרְשׁוּ יְהוָה לֹא־יִחְסְרוּ כָל־טוֹב :
לְכוּ־בָנִים שִׁמְעוּ־לִי יִרְאֵי־יְהוָה אֲלֹמֶדְכֶם : מִי־הָאִישׁ חֲתַפֵּץ חַיִּים
אֲהַב יָמִים לְרֵאוֹת טוֹב : נִצַּר לְשׁוֹנֵךְ מֵרַע וּשְׁפֹתֶיךָ מִדְּבַר מַרְמָה :
סוּר מֵרַע וַעֲשֵׂה טוֹב בְּקֶשׁ שְׁלוֹם וְרַדְפָּהוּ : עֵינַי יְהוָה אֶל־צַדִּיקִים
וְאֲזַנְוִי אֶל־שׁוֹעֲתָם : פִּנֵּי יְהוָה בַּעֲוֹשֵׁי רַע לְהַכְרִית מֵאֶרֶץ וּכְרָם :
צַעֲקוּ וַיְהוֹרֶה שָׁמַע וּמִכָּל־צְרוּתָם הַצִּילֵם :

Hb30 (S)

קָרוֹב יְהוָה לְגִשְׁבֵּר־לֵב וְאֶת־דַּבְּאֵי־רוּחַ יוֹשִׁיעַ : רַבּוֹת רַעוֹת צַדִּיק וּמִפְּלֹם יִצְלָנוּ
יְהוָה : שִׁמְרֵם פֶּלֶאֱסִיתִי־אֶחַת מִחֲפָזֶיךָ לֹא־גִשְׁבַּרְךָ : חֲסוּתֶיךָ רַשַׁע רַעַה וְשִׁנְאֵי
צַדִּיק יִאֲשֶׁמוּ : יִפְרָח יְהוָה גִּפְשׁ עַבְדָּיו וְלֹא יִאֲשֶׁמוּ פֶלֶאֱחֻסִים בּוֹ :

Hb31 (R)

הַכַּטְחִים בִּיהוָה כְּהַר צִיּוֹן לֹא יִמַע לַעֲוֹלָם יָשָׁב : יִדְוָשְׁלֵם הַדִּים סָבִיב לָהּ וַיְהוֶה
סָבִיב לַעֲמוֹ מִנְעִתָה וְעַד עוֹלָם : כִּי לֹא יִנּוֹת שַׁבַּע הַרְשַׁע עַל גּוֹרֵל הַדַּיִקִים
לַמַּעַן לֹא יִשְׁלַחוּ הַדַּיִקִים בַּעֲוֹלָתָהּ יְדֵיהֶם : הַטִּיבָה יְהוָה לַעֲוֹבִים וּלְיֹשְׁרִים
בְּלִבְבוֹתָם : וְהַמַּטִּים עַקְלֹקְלוֹתָם יוֹלִיכֵם יְהוָה אֶת־טַעְמֵי הַצִּיּוֹן שְׁלוֹם עַל־יִשְׂרָאֵל :

86772 Rés X 1665, f. 4

Transcription of the annotation

Ces cinq espreuves sont des lettres de [[Robert Estienne]]..... Les textes taillez a Paris en lan, 1541, par un nō(m)me Jehan Arnoul, dit le Picard, le jeune; et la glose taillee par aultre, bien pollie et bien achevee, sentant sa plume.

Translation of the annotation

These five specimens are the characters of [[Robert Estienne]] .. The characters for the text faces cut in Paris in 1542 by Jean Arnoul dit le Picard, the younger, and the gloss cut by another, well polished and finished, showing his hand.

Hebrew source:

Text composed of verses from Psalms 34:1, Psalms 34:2-7, Psalms 34:8-18, Psalms 34:19-23 and Psalms 125



Transcription of the annotation

Le gros texte de la Bible in quarto de Robert Estienne.

Translation of the annotation

The large text of the Quarto Bible of Robert Estienne.

Hebrew source:

Text composed of verses from Chronicles 1: 1-15.

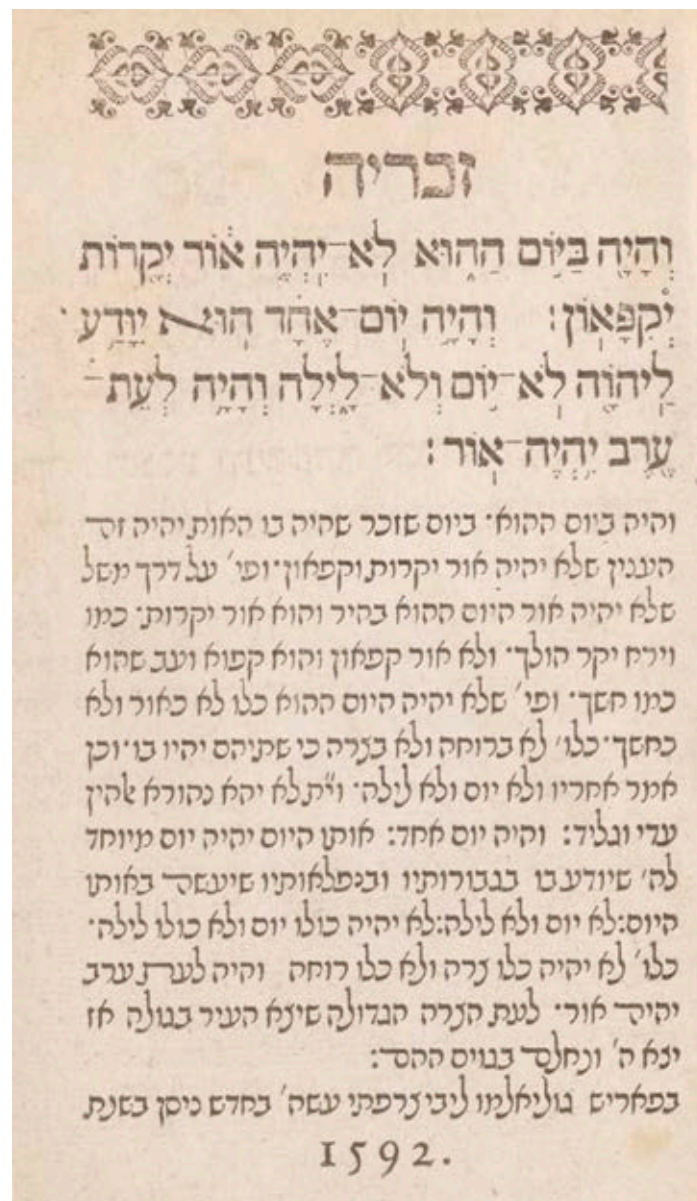

Hebrew source:
Zechariah 14:6-7. Final line is Le Bé's imprint.

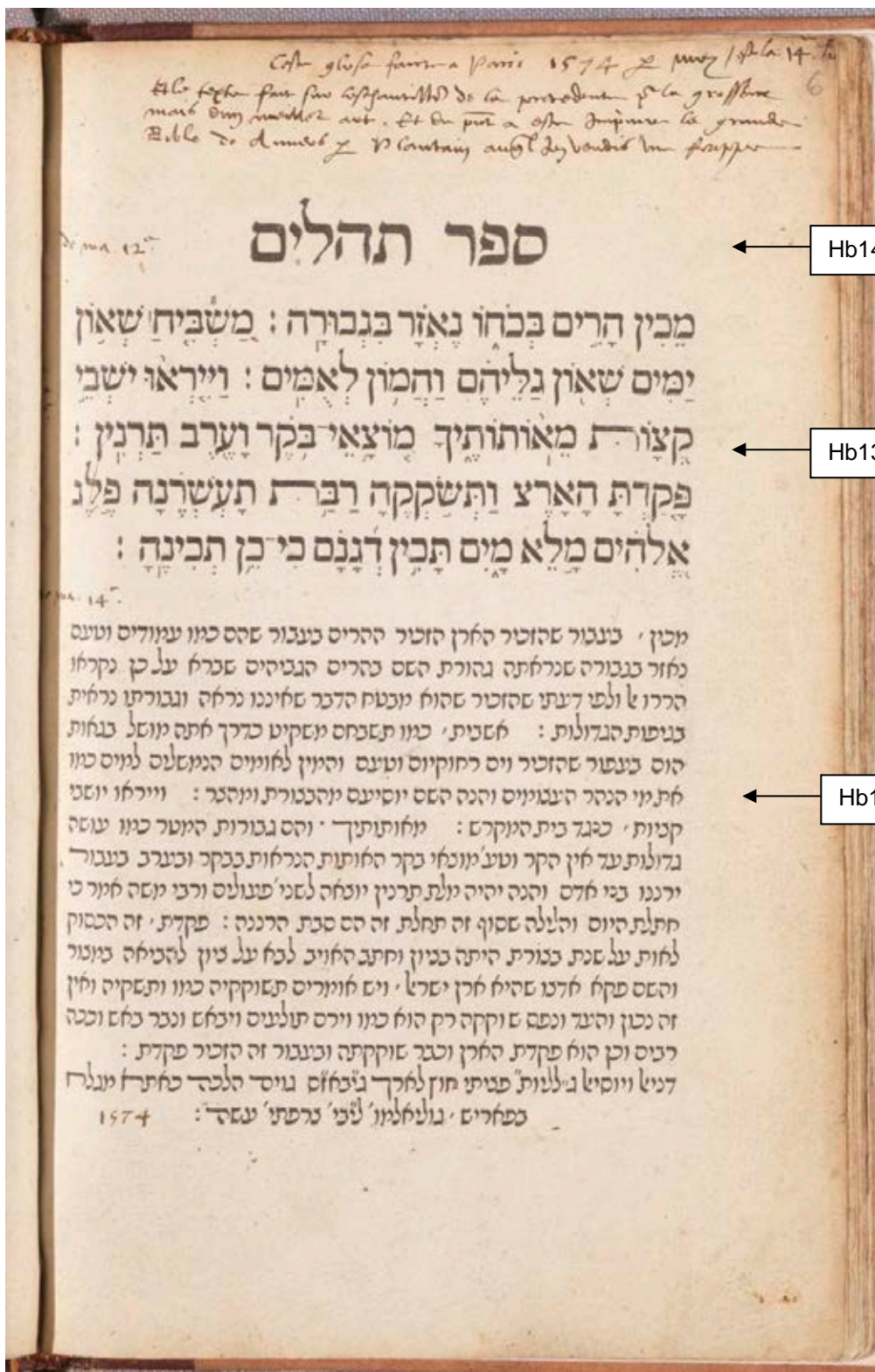

*Cette gloſe faite a Paris 1574 le 14. fev. 14. fev.
 Elle eſt faite ſur les eſcriptures de la premiere & la grande
 mais d'un maniere aut. Et de puis a eſte imprimee la grande
 Bible de Amſterdam & d'aujourd'hui auſſy d'aujourd'hui auſſy*

ספר תהלים

מִכֵּין הַרִים בָּכָחוֹ נֶאֱזָר בְּגִבּוֹרָה : מִשְׁבִּיחַ שְׁאוֹן
 יָמִים שְׁאוֹן גְּלִיָּהֶם וְהַמּוֹן לְאֲמִים : וַיִּירָאוּ יִשְׁבֵי
 קְצוֹתַי מֵאוֹתוֹתֶיךָ מוֹצֵאֵי בֶקֶר וְעֶרְב תִּרְנֵן :
 פְּקֻדַת הָאָרֶץ וְתִשְׁקֶקֶה רַבְרַת תַּעֲשֶׂרנָה פְּלֶג
 אֱלֹהִים מִלֵּא מַיִם תִּכְיֶן דָּגָנָם כִּי כֵן תִּכְיֶנָּה :

מִכֵּין . בְּגִבּוֹר שֶׁהַזְכִּיר הָאָרֶץ הַזְכִּיר הַהָרִים בְּגִבּוֹר שֶׁהֵם כְּמוֹ עַמּוּדִים וְעַמּוּ
 נֶאֱזָר בְּגִבּוֹרָה שֶׁנֶּאֱרָתָה גְּהוּרַת הַשֵּׁם הַהָרִים הַגְּבִיָּהִים שֶׁנֶּאֱרָא עַל כֵּן נִקְרָאוּ
 הַרְרוֹא לְוַשׁ דְּעֵתִי שֶׁהַזְכִּיר שֶׁהוּא מִכְּעַח הַדָּבָר שֶׁאֵינְנוּ נֹרְאָה וְגִבּוֹרֵתֵינוּ נֹרְאִית
 בְּגִישׁוֹת הַגְּדוּלוֹת : אֲשֶׁר־נִתְּנָה כְּמוֹ תִּשְׁבַּח מִשְׁקִיט כְּדֶרֶךְ אֶתֶּה מוֹשֵׁל בְּגִאוֹת
 הוּם בְּעֵשׂוֹר שֶׁהַזְכִּיר וַיִּם רְחוֹקִים וְעַמּוּם וְהַמּוֹן לְאוֹמִים הַגְּמֻשְׁלֵם לְמִיּוֹם כְּמוֹ
 אֶת־מִי הַנְּהַר הַעֲצוּמִים וְהַנָּה הַשֵּׁם יוֹסִיעֵם מִהַבְּטוֹרֵת וּמֵהַצָּר : וַיִּירָאוּ יִשְׁבֵי
 קְצוֹתַי כִּגְדַת בֵּית הַמּוֹקֶרֶשׁ : מֵאוֹתוֹתֶיךָ . וְהֵם גְּבוּרוֹת הַמַּטֵּר כְּמוֹ עוֹשֶׂה
 גְּדוּלוֹתֵינוּ עַד אֵין הַקָּר וְעַמּוּמֵנוּ אֵין בֶּקֶר הָאוֹתוֹת הַנֶּאֱרָאוֹת בְּבֶקֶר וּבְעֶרְב . בְּגִבּוֹר
 יִרְנְנוּ בְּכִי אֲדָם וְהַנָּה יִהְיֶה יִלְנֵת תִּרְנֵן וּנְבָאָה לְשֵׁנֵי פְּעוּלֵם וּרְבֵי מִשֶׁה אֲמַר כִּי
 חֲתַלְתִּי הַיּוֹם וְהַלְלֵה שְׁכוֹף זֶה תַּחֲלֵת זֶה הֵם סִבַּת הַדְּרַנָּה : פְּקֻדַת־זֶה הַכְּסוּק
 לְאוֹת עַל שְׁנַת בְּטוֹרֵת הִיִּתֵה כְּצִיּוֹן וְחַתְּבֵה אֲחֻיב לְבָא עַל צִיּוֹן לְהַצִּיאָה בְּטוֹר
 וְהַשֵּׁם פִּקָּא אֲדָטֵה שֶׁהִיא אֶרֶץ יִשְׂרָאֵל . וַיִּשׁ אֲוִימֵרִים תִּשְׁוֹקֶקֶה כְּמוֹ וְתִשְׁקֶקֶה וְאֵין
 זֶה נִכְוֵן וְהַעֲבֵד וּנְשֵׁם שׁוֹקֶקֶה רַק הוּא כְּמוֹ וַיִּרְם תּוֹלְעִים וַיִּבְאֵשׁ וּנְצַר כֹּאֵשׁ וְכַהֲ
 רְבִים וְכֵן הוּא פְּקֻדַת הָאָרֶץ וְכַבֵּר שׁוֹקֶקֶתָה וּבְגִבּוֹר זֶה הַזְכִּיר פְּקֻדַת :
 דְּנִיל וַיּוֹסִיל גְּלִלוֹתֵינוּ פְּצִיֵינוּ מוֹן לְאֶרֶץ גְּבִיָּהִים גְּבִיָּהִים גְּבִיָּהִים גְּבִיָּהִים כֹּאֲתִירָה מְגַלְחָה
 כְּפִאֲרִישׁ . גּוֹלְעֵלְמוֹן לְבִי גְּרַפְתִּי עֲשֶׂה־י : 1574

← Hb14 (S)

← Hb13 (S)

← Hb18 (R)

Transcription of the annotation

Ceste glose, faicte a Paris, 1574 p(ar) moy, est la 14e [[lettre]], et le texte fait sur l'eschantillon de la precedente p(ou)r la grosseur mais d'un meilleur art. Et du pres(en)t a este imprime la grande Bible de Anvers p(a)r Plantain, auquel jen vendis une frappe.

de ma 12e

de ma 14e

Translation of the annotation

This gloss was cut in Paris in 1547 by me and is my fourteenth characters. The main text type is done on the basis of the previous for size, but of a better quality. As of the present, it was used to print the Grand Bible of Anvers (*the Biblia Regia*) of Plantin to whom I sold a set of matrices.

Of my twelfth

Of my fourteenth

Hebrew source:

Zechariah 14:6-7. Final line is Le Bé's imprint.

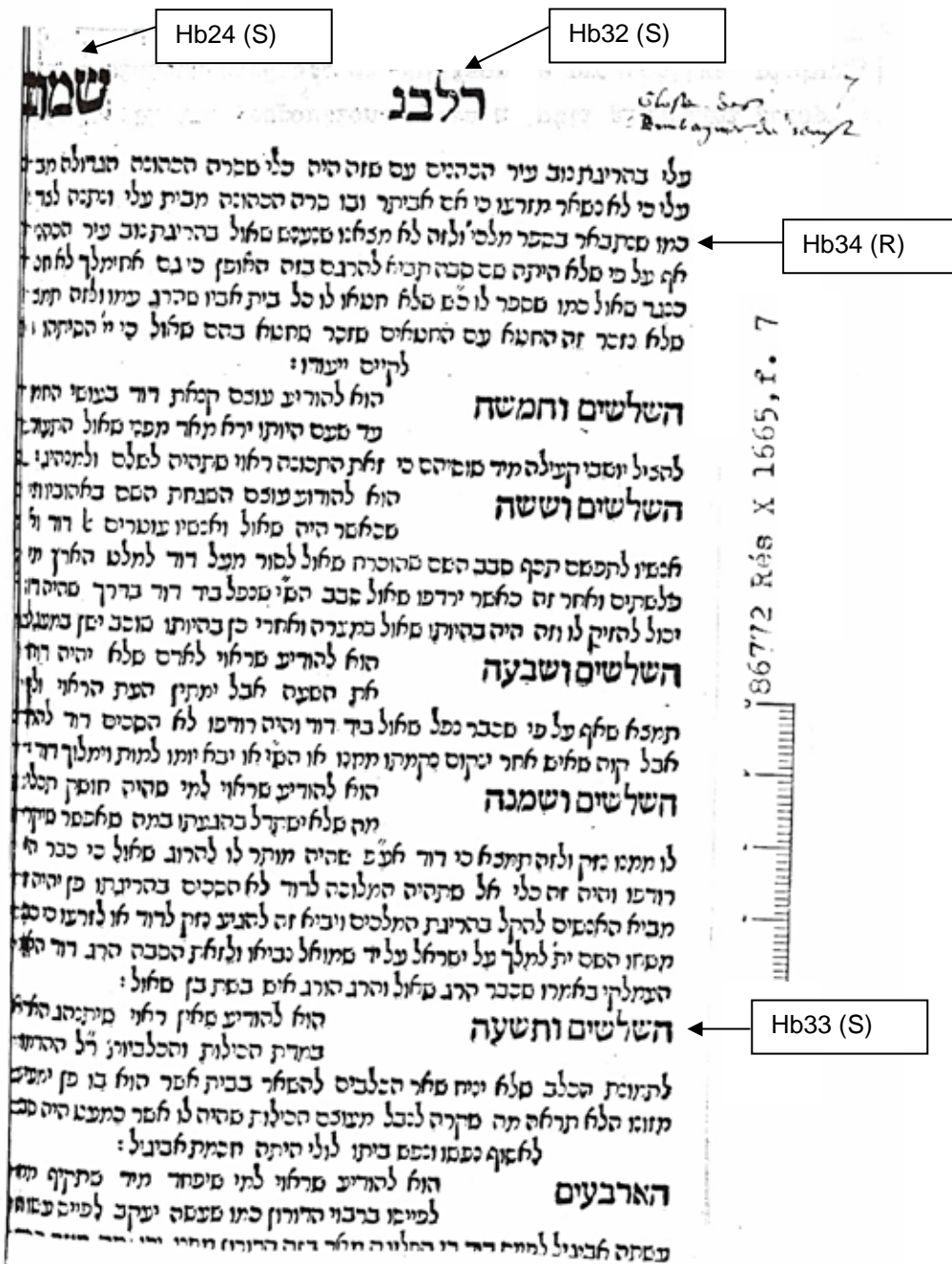

Transcription of the annotation

Glose des Bomberges de Venise

Translation of the annotation

The Bomberg gloss from Venice

Hebrew source:

Part of the page from 2 Samuel: 1-6 the Ralbag commentary in the third Bomberg *Biblia Rabbinica* of 1548.

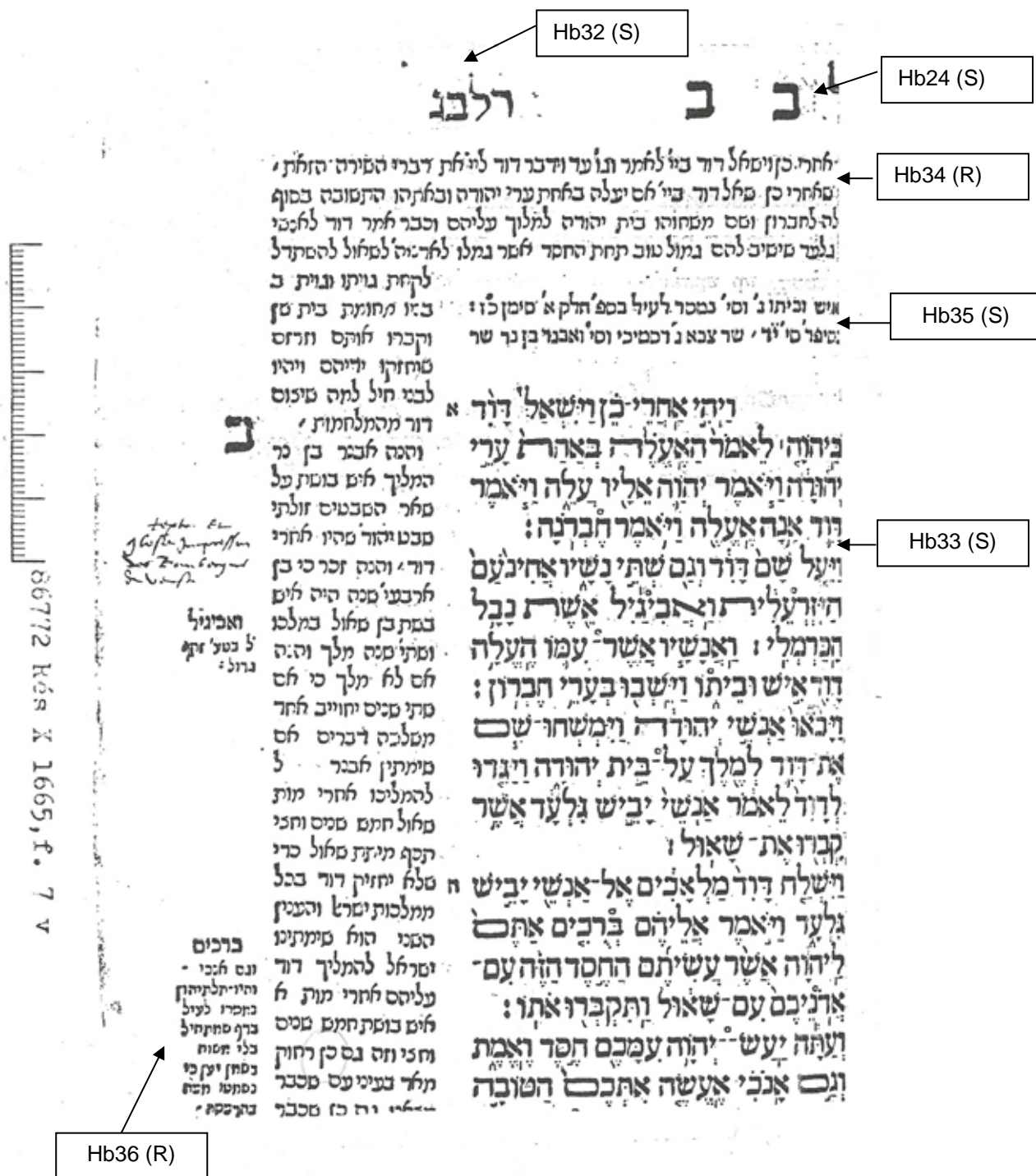

Transcription of the annotation

Texte et glose, impression des Bombergues de Venise.

Translation of the annotation

Text and gloss from Bomberg Venetian edition

Hebrew source:

Part of the page from 2 Samuel: 1-6 the Ralbag commentary in the third Bomberg *Biblia Rabbinica* of 1548.

אֵלָיו לֵאמֹר : בְּטָרִם אֲצֹרְךָ בְּכֶטֶן יִדְעִיךָ וּבְטָרִם תִּצְאֵה טָרָה
הַקִּדְשִׁיךָ נִבְיֵא לְגוֹיִם נִתְּיִיךָ : וְאָמַר אֲנִי אֶרְבִּי יְהוָה הַנֶּהֱוֶה
יִדְעִי דָבָר כִּי נֶעַר אֲנִי : וְאָמַר יְהוָה אֵלָיו
הֵאמֵר נֶעַר אֲנִי כִּי עַל כָּל אֲשֶׁר אֲשַׁלְּחֶךָ תִּלְךָ וְאֵת כָּל אֲשֶׁר יִצְאֶה
תִּדְבֹר : אֵל תִּירָא מִפְּנֵיהֶם כִּי אֲתָתָךְ אֲנִי לְהַצִּילָךְ נָאִם יְהוָה :
וְיִשְׁלַח יְהוָה אֶת־יָדוֹ וַיַּגַּע עַל־פִּי וַיֹּאמֶר יְהוָה אֵלָיו הִנֵּה נִתְּיִי דָבָר
בְּפִיךָ : רְאֵה הַפְּקוּדֵי־תִיּוֹם הַזֶּה עַל־הַגּוֹיִם וְעַל־הַמַּמְלָכוֹת לְנִתְּוֹ
וְלִנְתוֹץ וְלְהַאֲבִיד וְלְהַרוֹס לְבָנֹת וְלִנְטוֹעַ : וַיְהִי דָבָר
יְהוָה אֵלָיו לֵאמֹר מִתְּאֵתָה רָאִתָּה יְרִמְיָהוּ וְאָמַר סָקֵל שִׁקְדוֹ אֲנִי רָאִתִּי
וַיֹּאמֶר יְהוָה אֵלָיו הִיטַבְתָּ לְרֵאוֹת כִּי שִׁקְדוֹ אֲנִי עַל דְּבָרַי לַעֲשׂוֹתוֹ :

Hb37 (S)

Handwritten note:
מגן
ד"ר
20...

בספר הזה כל דברי כבואו סכבא על ישראל ועל הגוים וכן דברי עצמו מה טק
קתורין לפיכך נתלת כבואתן בעצמן ולו הן דברי עמוס דברי ירמיהו יל בעו
וכן עמוס הפך בדברי עמוס קטר עליך עמוס וכל הענין כמו סכתוב וכן בתוך
יהויהו' בן יאשיהו וכן בימי כדקיהו עד תום מלכותו סמלך יא סנה ובסנת אחו
מלכים : בטרים אכורך כן כתי' בוי' וקרי הכר' בקמץ חטף כמספטו עם הכנני
הארבע ידעו בכח הטבע ואחר כך הוציאו לפעל . וכן אמר ישעיהו מעתה ה
לפעל וסלחני ברוחו או פי' ידעתך כמו ידעתך בפס סאמ' למטה ומורה עליו
יס לסאל והלא כל הנביאים והנדייקים וכן הרשעים בטרים הבראם ידעם והם
מקורם . והחכם הגדול ר' משה בר מיימון זל כתב כי זה ענין כל כביא חי אס
יש לרעתו ליסאל למה לא אמר זה הענין לכביא אחר אלל לירמיהו .
מוכף לכבואה מן הבטן כדי סיחזק לבו ללכת בסליחות האל . ואם תאמ
אות גדול לחזק את לבו והוא אות הסנה והאותות האחרים לפני פרעה . וגם
יכירת האדם יש הכנה טבעית לכבואה למי שהוא עתיד להתכבא ולא זה בלבד
היכירה יגבר בה עם ההתלמדות . וינתן תרג' הפסוק כן ער לא בריתך נ
מניתך : ואומר אהה . לסון קריאה על הצער ועל הראגה ומה סאמר לאי
לו כבואה והוא כער כי הכה גם כן סמואל היה כער בתחלת כבואתו כמו סכתו
ואעפ' שהוא גדול בסנים יקרא כער כמו סכתוב ומסרתו יהוסע בן כון כער .
את השליחות לא בידי כמו סאמ' משה רבינו סלח כא ביד תסלח . והמש
ואמרית קבל בעותי ה' הא לית אבא ידע לאתכבא' ארי רבי אבא ומסריותי עקא
וכן וילך חלקנה הרמיתה על ביתו כמו אל ביתו . ומה סאמר אסלחך תלך כי
לרונה אמ החלר ואם ימנו ורוננו ומה...

Hb34 (R)



Transcription of the annotation
Moyenne des Bōbergues

Translation of the annotation
The Bomberg Moyenne text

Hebrew source:
An unidentified Bomberg quarto Bible and comprises part of Jeremiah, part of two
Haftarot, those for 'Shemot' and 'Mattot' (Jeremiah 1:4)-12

הפטרות וארא כיהוקאר בטיסן כו

נה

אמר ארני יהודה בקבצו את בית ישראל מן
העמים אשר נפצו כם ונקדשתי כם לעיני
הגוים וישבו על אדמתם אשר נתתי לעבדי
ועקבו וישבו עליה לבטח ובנו בתים ונטעו כרמים וישבו לבטח
עשותי שפטים בכל השאטים אותם מסביבתם וידעו כי אני יהוה
אלהים: בשנה העשירית בעשרי בשנים
שר לחדש היתה דבר יהוה אלי לאמר: בן אדם שים פניך על פרעה
לך מצרים ודעבא עליו ועל מצרים כלה: דבר ואמרת כה אמר
יהוה הנני עריך פרעה מן מצרים התנים הגדול הרבץ בתוך
ארץ אשר אמר לי יארי ואני עשיתיני: ונתתי תמיים בלתיך
ותפקתי דגת יאריך בקשקשתיך והעליתיך מתוך יאריך ואת כל
גת יאריך בקשקשתיך חרבק: ונטשתיך המרברר אותך
את כל דגת יאריך על פני השרר תפול לא תאסף ולא תקבץ
ותת הארץ ולעוף השמים נתתיך לאכלה:

חן להכלך למסתר פתגמי כבואתך: להבילך: שלא ממתוך: הלוך.
דוסלס ומדבר כנגד העיר כאלו מדבר כנגד העם: זכרתי לך חסד כעודיך.
ם אעניס המריעים לך כי זכרתי לך חסד כעודיך. וענין חסד כעודיך אהבת
ימרי דאזלו בתר תריץ שלוחי בתר משה ואהרן. במדבר ארבעין סנין בלא
ברהם יחוק ויעקב שהיו אכסי חסד. או אהבת כללותיך פי' חסד כעודיך. והכל
שהעברים קודמים לבחורים ולזקני'. ופי' כללותיך עם מן כלה כי כנסת ישראל
דעם שלא יאכלכו זר. ומה שאמר ראשית תבואתה הוא כפל ענין במלות סוט' כי
גדאל אף על פי שהקבה מביא עליהם האויב הוא כעכס עליהם כי זוכר להם
גדאל כחרבה בבל כמו שכתוב: תבואתה. כתוב בהא במקום וזו כמו אהלה
בית ישראל קדם ה' ועל בזויהון כדמעא ארמו' עללא דמאן דאכיל מיניה חייב
א על גבי מדבחא כל דאכיל מניה מתחייב אף כן כל בזויהון דבית ישראל
האלף בסוף לברו: הפטרות וארא

זכרתי לך חסד כעודיך: זכרתי לך חסד כעודיך: זכרתי לך חסד כעודיך:
זכרתי לך חסד כעודיך: זכרתי לך חסד כעודיך: זכרתי לך חסד כעודיך:

Hb35 (S)

Hb24 (S)

Hb37 (S)

Hb34 (R)

36772 Rés X 1665, f. 8 v

Hebrew source:
An unidentified Bomberg quarto Bible and comprises part of Jeremiah, part of two
Haftarot, those for 'Shemot' and 'Mattot' (Jeremiah 1:4)-12

Hb24 (S)

Hb32 (S)

דדק

Hb34 (R)

Hb35 (S)

Hb37 (S)

Hb35 (S)

Hb36 (R)

ומשחו סם את דוד ואף על פי שבכר היה נמשח פי שמואל אף על פי כן
 סך לוחו עליהם למלך משחיהו: ויגדו לדוד לאמר איש יבס גלעד פי דבר
 יבס גלעד: אשר קברו את שאול או הוא כמו הסוך אשר קברו אנשי זבג גלעד
 את שאול: הטובה הזאת: גמול הטובה הזאת: ויעברו מחסם דעה להגלעד
 תחלה מעבר הירדן והעבירו
 מחסם כי הוא מצוע גבול סם
 טבטוס וחזי שהרי מחסם גבול
 בני גד וגבול בני מנשה ואף על
 פי שדע אבסר כי דוד נמשח
 למלך על ידי שמואל היה מתחזק
 להשמד עדיין מלכות שאול כפי
 סודו דמירס ויאמר אלהים
 אל יעקב אזי אל מדי פרה ורבה
 וגו' אמרו מכאן דרס אבסר
 דרס לאיש כמת בן שאול אמר
 החיוב ומלכות מחלנך ו
 יבאו ועל בזמן כאמר סלא סולר
 לדיון ועד עכשו לא עמד מ
 מביתן חלא סאול לפיכך לקח
 איש כמת וימליכוהו אל הגלעד
 וגו' וימליכוהו אל הגלעד אל
 במקום על כמו אל ההרים לא
 חבל וזולתו המליכוהו תחילה
 מעבר לירדן ובארץ ישראל: אל
 האסורי ואל ירעאל וגל אשרים
 וגל בזמן: ואחרי אשר אמר על
 יסר סלו למה זכר לה המקומות
 יס לפרס כי בסוכו ממחסם
 היה וזה היה אחרי מלחמת
 הערים ססב אבסר אחרי ה
 המלחמה למחסם אל איש כמת
 ואלו העבירוהו אל אלה המקומות
 רחוקים מן סוכו לביתו בארץ

דכינו ישעיה

כפי הסוד
 ההר קרא על סם
 הכין והיו בו הרב
 עינית יבן אכיד
 סה אס כסן כן
 האיל יס היה
 כצמות הילך כעב
 נעל והיו כס סאל
 יונתן ויסור וסלבי
 סוע ואל תה אז
 איש כסן והיה כל
 כך גדול יס נותר
 איתם סס ססיה
 סס היו חנאין עשו
 לתחמת ולסיה חס
 איתם ואיש כמת
 היה תחיל על ביתו
 ולפיכך נא תיא:

Transcription of the annotation

Textin des Bombergues

Moyenne des Bombergues

Translation of the annotation

The Bomberg 'textin'

The Bomberg 'Moyenne'

Hebrew source:

**Part of the page from 2 Samuel: 1-6 the Ralbag commentary in the third Bomberg
Biblia Rabbinica of 1548.**

Hb32 (S)

נ א רלבג שלא

Hb24 (S)

הסבה המעיד לרוד מלא יסב את אכיס בעיר המלוכה:

ורבעים וארבעה

והוא בדעות הוא להדיע כי הודעת
העתידות תגיע לאדם מצד ההסגחה
לסות ולזה ספר שלחמא שאל לא עכאוי אפי על יד אחר מבני האנשים וכן
אעכא בחלומות הצודקים ולא באורים כי אף על פי שמורה שהיו עם אורים
מש הנה לא היה עם שהן ראוי סיהיו כסאלים באורים ותמים כי כבר המת
ול הפלמים מהכהנים אשר התנה להם ההסגחה הגדולה בהרגו טוב ציר
הסם ולא היה עם שהן גדול עם מלא היה עם שהן גדול סרוח הקדם סורה
ז סיתקן סיהיו כסאלים באורים ותמים ולזאת הסבה תמצא שלחמא יהותק
בז על סבועת אביו לא ענה הפי אל שאל בהיותו כסאל באורים ותמים ושאל
גם אז כי החמא גרם לו מלא יעכאוי ולזה חקר על פי הגורל במה היתה
ואת הזאת היום ומזה המקום התבאר שהוא אפשר טעלים הפי מהבניא
קצת העתידות מצד האכיס אשר יקחו תועלת בהודעה ההיא:

Hb34 (R)

ורבעים וחמשה

Hb33 (S)

הוא להדיע אך מלא הסם ית'
לשאל את גמולו הוא הרג טוב עיר
הסם ובא עת מהרגים במה פסקד ממנו בהריגתם עי מהסרח לטות
ז יאברים הפחותים והם האובות אחר סכבר הרחיקים ובצדם מן הארץ
למען תגיע לו איו האדעה בעמק המלחמה:

ארבעים וששה

הוא להדיע שאין ראוי סיתחבר האדם
עם הרשעים הלא תראה כי בהתחבר רוד
פלמתיס למלחמה סרץ הפי מעשיו והיה זה סבה אל טעפרה סקלב וטטבו
פי הוטף אשר בה והנה להסגחה על רוד סבב הפי מלא הססמנו סרני פלמתיס
ך אדם רוד במלחמ' כי יראו סן יעסה תחבולה להעלים ביד שאל למען יתקדשה
אל אדיתו והיה זה סבה אל סהביל רוד כל אשר לקח עמלק ממנו ולקח מהס
רב והנה היה בזה היסרה אל סתגיע המלוכה לרוד בראות יסראל הצלחתו
סמו סזכרנו במה סקדים:

רבעים ושבעה

הוא להדיע סראוי לאדם סושלח לחמו על
פי המים להיטיב לדלים הרעבים כי בזה
ין הסכחה הטובה בצמק החמלה מה מלא יעלם עם סכבר ייקרה סגוע
ס מהמקבל גמול טוב על זה הלא תראה כי רוד בחמלתו על האדם המכרי
נאווה בדרך רעב וצמא האכילהו והסקהו ונתן לו פלח דבלה וסני צמוקים
ז זה סבה אל סהורהו מקום הגיד ספסטו על סקלב והיה זה סבה אל סהטיל
רוד כל אשר לקחו עמלק:

86772 Rés X 1665, f. 9 v

Hebrew source:

Part of the page from 2 Samuel: 1-6 the Ralbag commentary in the third Bomberg *Biblia Rabbinica* of 1548.

*Tout mes yeux se voyent aller à la gloire de Dieu par la main de son saint Esprit
 Justification par la gloire de son Verbe par la main de son saint Esprit
 1546. an de sa vie 22 ans 17. de sa vie 2. de sa vie 6 de sa vie*

מוזמר לאסף ← Hb3 (S)

אלהם באו גוים בנחלתך טמאו ארץ היכל
 קדשך שמו את ירושלם לעינים נתנו את
 נבלת עבדיך מאכל לעוף השמים בער
 חסידך לחיתו ארץ שפכו דמם במים
 סביבות ירושלם ואין קבר היינו חרפה
 לשכנינו לענוק ולסביבותינו יעד מר
 יהודי תאנף לנצה תבער כמו אש קנאתך ← Hb4 (S)
 שפוך חמתך אל הגוים אשר לא ידעוך ועל
 ממלכות אשר בשמך לא קראו כי אכל את
 יעקב ואת נוהו השמו אל תזכר לנו זנות
 ראשנים מהר יקדסונו רחסיך כי דלונו מאד
 עזרנו אהי ישענו על דבר כבוד שמך והצילנו
 וכפר על חטאתינו למען שמך לפה יאמרו
 הגוים איה איהם יודע בניים לעינינו נקמת
 דם עבדיך השפוך תבא לפניך אנקת אסיר
 כגדל זרועך הותריבני תמותרה והשב
 לשכנינו שבעתים אל היקם חרפתם אשר
 זרפוך יהוה ואנחנו עמל וציון מרעיתך
 גורח לך לעולם לדור ודור נגדך תהלתך
 גוליאלמו ליבי צרפתי
 מרבה נפסים מרבה ראנה אזצה טזק תמן

91633 Rés X 1665, f. 10

Transcription of the annotation

Texte moyen q[ue] jay taille a Venise p(ou)r le Magnifique m(esse)r Marc Antonio Justinian, gentilhōme Venitien, qui est la 2^e lettre q[ue] jay taillee, en lan 1546, aage de 20 a 21 ans.

Translation of the annotation

'Moyen' text which I cut in Venice for the exalted Master Marco Antonio Giustiniani, Venetian Nobleman, which is the second character I cut in the year 1546 then aged 20 to 21 years

Hebrew source:

Psalms 79: 1-5. Final line is Le Bé's imprint.

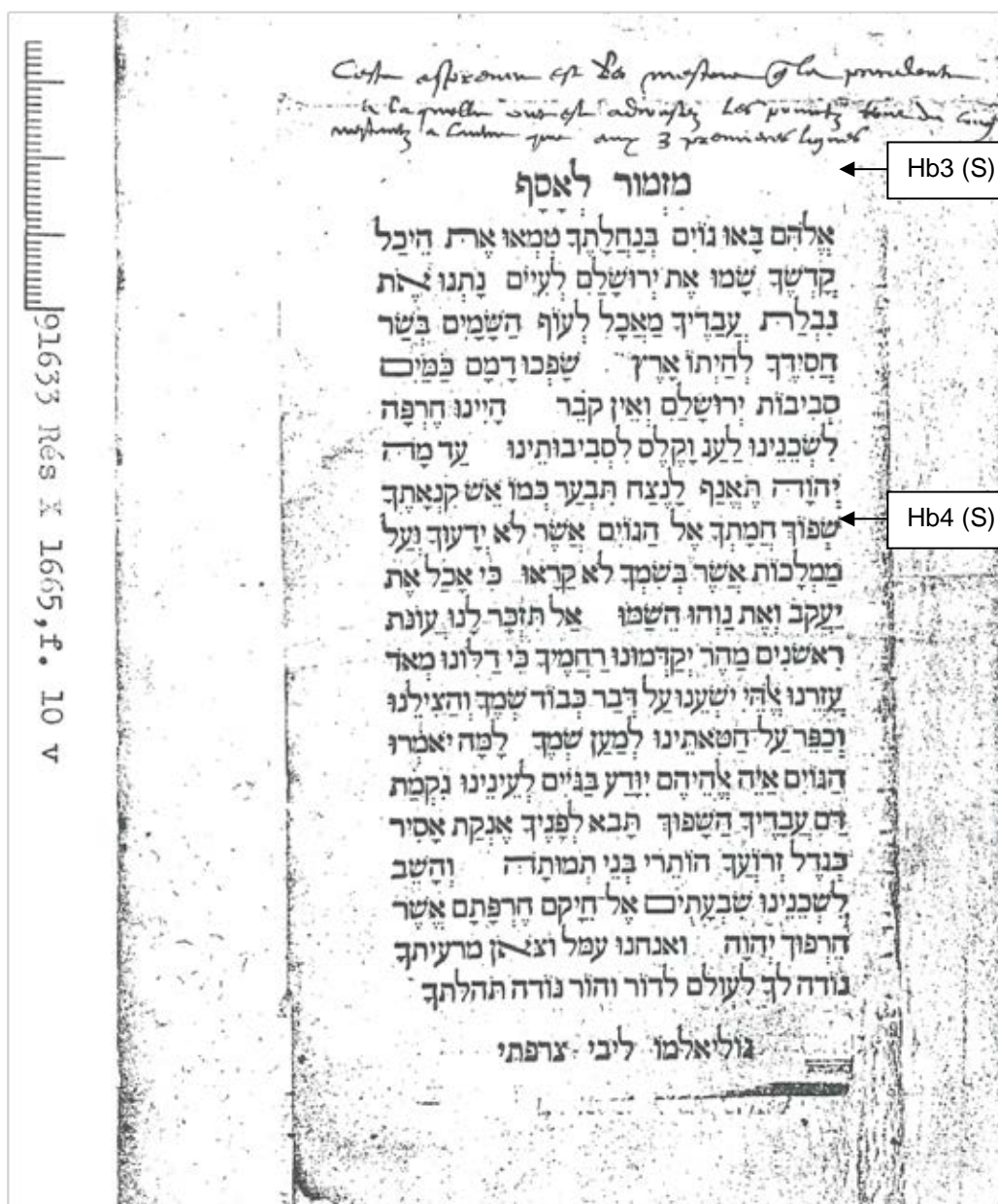

Transcription of the annotation

Ceste espreuve est la mesme que la precedente a laquelle ont este adjoutez les pointz tout du long, n'estanz a l'autre que aux 3 premieres lignes.

Translation of the annotation

This specimen is the same as the previous to which have been added throughout the vowels, as the previous specimen had them only on the first three lines.

Hebrew source:

Psalms 79: 1-5. Final line is Le Bé's imprint.

*Copy deposited off the extra high-copy tulle for May 21, 1947
by May 1947 copy for 22 and 10 of 20-20 of Ziffer of my tulle*

*Copy of the tulle plus and tulle
is being made by the tulle*

לאחד אין דורשין לו אא אם כן היה קבס ומבין מדעתו מוסרין לו ראשי
פרקים וענין מעשה בראשית מלמדן אותו ליהוד אף על פי שאינו מבין
מדעתו ומודיעין אותו כל מה שיכול לידע מדברים אלו ולמד
אין מלמדו אותו ברבי לפי שאין כל אדם יש לו דעת רחב להשיג פירוש
וביאור כל הדברי על בודיון: בזמן שאדם כתבונן בדברים אלו ומכיר
כל הברואים ממלאך ונגלה ואדם כיוצא בו וראה חכמתו של הקב"ה
בכל היצורים וכל הברואים מוסף אהבה למקום ותצמה נפשו ויכמה
בשרו לאהוב המקום ברוך הוא ויראה ויפחד משפלותו ורלוותו וקלותו
כשעריך עצמו לאחד מהנפשות הקדושים הגדולים וכל שכן לאחר
מהצורות הגדולות הנפרדות מן הנולמים שלא נתחברו בגולם כלל
וימצא עצמו שהוא ככלי מלא בישות וכלי מהירק וחסר: ועניני ארבעת

Hb1 (S)

מגדל עון
בזמן שאל מתבטן עד רק ומסר
פרק כמה מדלוקין ועניני ארבע
פרקים אלו וכו' עד סוף הפרק
פרק אין דורשין:

פרק המשי
בית מלמל מוטוין
על קדו השם עד
בין שלמטם בערך

Hb24 (S)

Hb7 (R)

Hb6 (S)

91653 Res X 1665, f. 11

Transcription of the annotation

Ceste impression est du petit texte q[ue] j'ay taille p(ou)r May de Parensse a Venise, en lan 1547 aage alors de 22 ans / et est de la 4^e lettre q [ue] jay taillee. Ceste glose aussi taillee p(ou)r ledit audit temps et les motz du tiltre plus gros.

Translation of the annotation

This specimens shows the petit texte which I cut for Meir di Parenzo in Venice in the year 1547 at the age of 22 and is the fourth character which I produced. The gloss was also cut for Meir di Parenzo at the same time and the larger words for the titles.

Hebrew source:

Section of page from the 1550 Bragadin edition of the Mishneh Torah; The first book Sefer Mada, Yesodey haTorah - Chapter 5

ספר בראשית

ואל בניו אתו לאמר : ואני הנני מקים את בריתי אתכם
 וארני ורעכם אחריכם : ואת כל נפש החיה אשר
 אתכם בעוף בבהמה ובכל חית הארץ אתכם מכל יצאי
 והתבה לכל חית הארץ : והקמתי את בריתי אתכם
 ולא זכרת כל בשר עוד ממי הפגול ולא יהיה עוד מפול
 לשחת הארץ : ויאמר אלהים זאת אות הברית אשר
 אני נתן ביני וביניכם ובין כל נפש חיה אשר אתכם
 לדור עולם : את קשתי נתתי בענן והיתה לאות ברית
 ביני ובין הארץ : והיה בענני ענן על הארץ ובראתה
 הקשת בענן : וזכרתי את בריתי אשר ביני וביניכם ובין
 כל נפש חיה בכל בשר ולא יהיה עוד הפיגם למפול
 לשחת כל בשר : והיתה הקשת בענן וראיתה לזכר
 ברית עולם בין אלהים ובין כל נפש חיה בכל בשר אשר
 על הארץ : ויאמר אלהים אל נח ואת אות הברית
 אשר הקמתי ביני ובין כל בשר אשר על הארץ :
 והיו בני נח היצאים מן התבן
 שם וחס ויפת והם הוא אבי כנען : שלשה אלה בני
 נח ומאלה נפצה כל הארץ : וחל נח איש האדמה
 ויטע כרם : וישת מן היין וישבה ויתגל בתוך אהלה :
 וירא חם אבי כנען את ערות אביו ויגיד לשני אחיו נחושב
 ויקח שם ויפת את השמלה וישמו על שכבם שניהם
 וילכו אחרנית ויכסו את ערות אביהם ופניהם אחרנית
 וערות אביהם לא ראו : ויקח נח מיינו וידע את אשר
 עשה לו בנו הקטן : ויאמר ארוור כנען עבד עבדים
 יהיה לאחיו : ויאמר ברוך יהוה אלהי שם ויהי כנען
 עבד לכו : יפת אלהים ליפת וישבן באחלי שם ויהי
 כנען

Hb38 (S)

86772 Rés X 1665, f11 v, face

Handwritten signature or note

Transcription of the annotation

(Not legible and possibly in another hand than of Guillaume I Le Bé)

Hebrew source:

Genesis 9:9-27

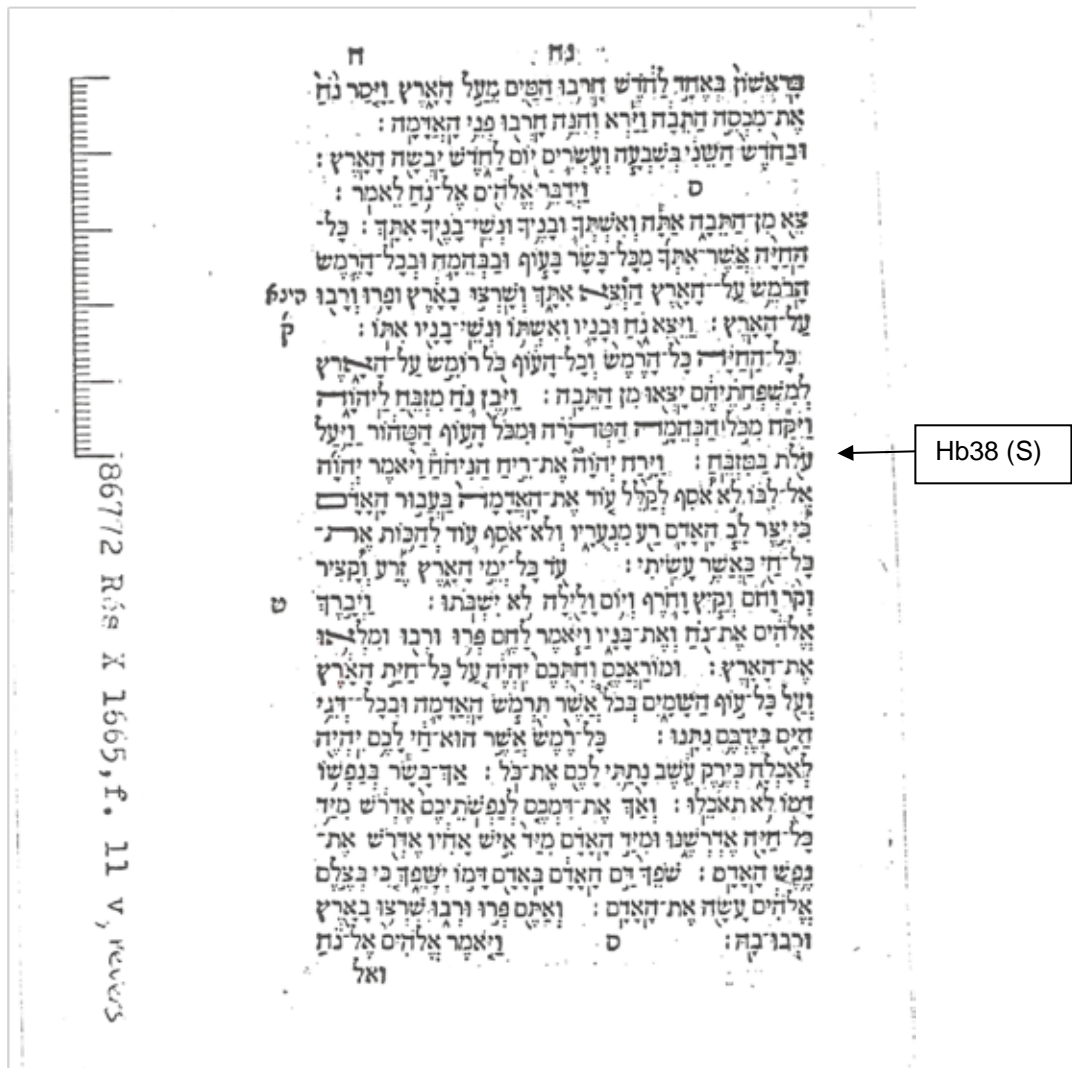

Transcription of the annotation

(The annotation is located at the top of the page and not visible on this scan).

Ce petit texte est de Justinian, taille p^r un graveur de monnoye et cachetz a Venise.

Translation of the annotation

This Petit texte is from Giustiniani, cut by an engraver of coins and seals in Venice.

Hebrew source:

Genesis 8:13-22 and Genesis 9:1-8

*208. 1665
Ce petit livre a été imprimé par le sieur de la Roche
pour de plus commodité aux étudiants de la ville de Paris
l'an de la république de France le 1547 le 4. de 5.
Lecteur de la Faculté de Médecine*

בשר שנמלח ושהה כדי מליחה ושמוהו בקדירה לבשל בלאהדחה
מוותרשכבר פלט דמו ולא נשאר רק מעט דם מן המלח ואותו הדם
בטל כס' כי אין לך שום חתיכ' שנמלחה ושהתה כדי מליחה שלא יהא
בה ס' כנגד דם שעל המלח כדוש' שהמים שבקדיר כמזקן מנערשין
לבטל הדם אבל אין

Hb10 (S)

בשר שהורח וגמלה ושהתה
כדי מליחה ואחר כך
הניחו אותה לבשל בלא הדרחה מית'
אם יש ס' בהתיכ' ובתבשיל כנגד
לחלוח' דם ומלח שעל החתיכ' מבחוץ
לפי שאין המלט הנר'ב מבטוץ נאסר
לא בשביל דן הנבלע בו אבל לא יאסר
יותר מאלו היה המרה הנר'בק מבחוץ
כולו דם דהוי בטל בששים ולא שייך
כאן לדמורת לחבלין שלעז' רעביון
טעמיה ולא בשישי' שגב המלחה
הכי הכשר שנמלח ו

Hb6 (S)

Hb7 (R)

ושהה כשיעור גלויים והושם בקדירה בלא הדחה שהוא מותרת ש
שהחתיכה גופה והרוטב מכטלן אותו דם דנפיק מינ' משום דחתיכ'
שנמלחה פלטה כל הדם לחון וריח התיק' נמור ולא איסור אלא דם
שעלו לך חתיכה גופה וכל מה שבקדוס מנערף לבטל האיסור גם
וכן כהג' מהרס להתיר: עב' על תרי הגה' אילו מאז דאמאז בבתרא
הצריך לצרף כל מה שבקדירה לבטל מה שאין כן בראשונ' דחתיכה
גופה מכטלת בלתי שום צרוף ויש לחלק בין חתיכה עבה דדמה
מרוכה ומלחה מועט וכן חתיכה קלושה דמלחה מרוכה דדמה מוע
עב': היינו שיעור מיל' כרס' והרמבם וסמך לדבר במלח כגמט
מיל' ושיעור מיל' שליש שעה פחות חלק אחד והיינו דוקא לקדירה
ואם לאו אף הקדירה אסור ואש' אם הושם רק בגלי תאשון שהיד
כלתו בו וכוז' יהיה אודם שהתחיל לוהכו יהודי ג' כשטיהן מתין
בוניציאה גול'אלמו ליבי צרפתי

1547 5 48

BIBL. NAT. 656 Rés. X 1665, f. 12
SERVICE PHOTOGRAPHIQUE
PARIS
REPRODUCTION INTERDITE

Transcription of the annotation

(Above) †Dest ceminde?† ce Ce petit texte et glose grosse et ce mot de petit canō(n) sont de mes ouvrages, faitz a Venise / le texte et glose faitz p(ou)r Mazo de Parenza, cō(m)me est cy devant dit en lan 1547 les 4^e et 5^e lettres de mes fassons.

(Below) 1547 et 48

Translation of the annotation

This Petit Texte, large gloss and word showing the Petit Canon are typefaces by me, cut in Venice. The Texte and the gloss cut for Meir di Parenzo, as it is stated underneath in the year 1547 and these are the fourth and fifth typefaces of my making.

Hebrew source:

Assembled text dealing with Halakhic rules of Kashrut and the salting of meat. Final line is Le Bé's imprint.

Hb24 (S)

Ces lettres cy sont des precedents 4^e & 5^e lettres de mes ouvrages p(ou)r ledit Maggio

Hb6 (S)

עשרה סגנון לשון מים פרוץ און
 מעמידין ומפרץ בן סורר ומורה
 ומומץ פרוץ וספחים פרוץ
 כל שעה וענין קדוש הסם סעודת
 סגנון כפרות חמור אל הכהנים
 ובסגנון פרוץ ד' מיתות ובסגנון
 ונקדשתי כתר בני ישראל על מנת
 בן הונאמי אלקם מאלר מננים
 על מנת שתקדשו שמי כפרים וכן
 כתב למלך סגנון : כל

אמרו חכמי דבר נחול מעשה מרכבה ודבר קטן הווין ראביני ורבא ואף על פי
 בן ראויין הן להקרימן שהן מיישבין דעתן של אדם תחלה ועוד שהן הטובה
 הגדולה שהשפיע הקבה ליישוב העולם הזה כדי לתול חיי העולם הבא
 ואפשר שידעם הכל קטן וגדול איש ואשה בעל לב רחב ובעל לב קצר :

פרק המישי
 הגנה
 בית ישראל בצויון על קדוש
 השם הגדול הזה ש' ונקדשתי
 בתוך בני ישראל ובחורין של
 לחלו שגאמר ולא תחלו את שם קדשי
 כיצד בשעה שיעמוד נוי ראום את ישראל לעבוד על יעבור ויהי אדם מכל מצות האמורות בתורה או יהרגו יעבור ואל
 ודרג שגאמר במצור אשר יעשה אמורים בשאר מצות חרין מעבודה זרה ויגלו
 בתחיב כנפשו כמר דברים אמורים בשאר מצות חרין מעבודה זרה ויגלו
 עריות ושפיות דמים אבל שלש עבירות אלו אם יאמרו לו עבור על אחרת
 סתן או חרין יהרג ואל יעבור במה דברים
 אמור' בזמן שהגני מתבין להנאת עצמו בנות
 שאנסו לבנות לו ביתו בשבת או לבשל לו
 תבשילו או אנס אשה לבעולה וכיוצא בזה
 אבל אם נתבון להענין על המצות בלבד אם יהיה בינו לבין עצמו ואין שם
 עשייה מישראל יעבור ואל יהרג ואם אנסו להעבירו בעשייה מישראל יהרג.

פרקים אילו שבחמט מצורת אלו הם
 שחכמים הראשונים קוראין אותן פורס
 כמו שאמרו ארבעה נבנו לפרס
 ואף על פי שגדולי ישראל היו וחכמים
 גדולים היו לא כולם היה בהן חכ לידע
 ולהשיג כל הדברים על בודין ואני
 אומר שאין ראוי לטויל בפרס אלא
 מי שנתמלא בריסו לחם ובשר ורחם
 ובשר הוא לידע האמור והמות וכיוצא
 בהם משאר המצות ואף על פי שדברים
 אלו דבר קטן קראו אותן חכמים שהרי
 אמרו חכמי דבר נחול מעשה מרכבה ודבר קטן הווין ראביני ורבא ואף על פי
 בן ראויין הן להקרימן שהן מיישבין דעתן של אדם תחלה ועוד שהן הטובה
 הגדולה שהשפיע הקבה ליישוב העולם הזה כדי לתול חיי העולם הבא
 ואפשר שידעם הכל קטן וגדול איש ואשה בעל לב רחב ובעל לב קצר :

הנהגה
 כבודת כהנים ממשמשט'
 לא תחללו את שם קדשי אלא
 תלמוד למר ונקדשתי למי תורה
 מסור ענין על קדוש שמי שם :

קיינו דווקא כאם אכל אשה
 קרקע שעלם הוא אם לא עשתה
 מעשה כגון להביא ערוה עליה
 כמעשה כגון סורר ומור דפרץ
 והא אסור פרהסוף הויה ולא
 פרוץ גנו עריות הוא אלא מ
 מפרסוף פרוץ משום חילול

קיימי ומוחי סקוים סבורא כדכתי'
 וקתיעו ית במוק' לאמי שמי' מוח'
 וקוים לפי שאיערך כענין לב
 אלו ידע שהוא אינו נחשב לגנום
 כמו שאמר ארון הכסאיים ונחנו
 מה ולש שהטונו כל או הענינים על
 כריון הויה עני מוח מכל האדם:
 וענין ל' פרוקים שבחמט מפת אלגו
 וכו' חמט המנות הם לידע שיש
 סם חלטה וסלג לעלות במחמטה
 שם אלוה וולתו ולמדו ולאסו
 ולראה ממנו : הם שהחכמים
 קורין אותן פרס כדגרוס' כחונ'
 פ' סני ל' נכנסו לפרס בן עמי
 וכן זומא ואחר ור' שקיבא בן עמי
 הנין ומת בן זומא הנין וכענין
 אחר קין כענינות רבי שקיבא
 נכנסו בגנום ויהא בגנום ויקרא
 זה הענין פרס בגנום כענינים
 האחד כמו שהפרס יס מופי
 מבריס שהם תאווה לענין וכחמדי'
 למחמט ישנות מים מים שהם
 משמחי לב ומחמט' הנפש כן או
 הענינים ועוד שהפרס בגנום
 לו האד' יתנא חילנות רבי ובתולה
 לא ידע מה הוא השרי סלגה ומס
 תועב כל פרי ושקטוב בהם מעט
 מעט ויתגלה לו סוד כל אחד ואחד'
 מהם וטעמו והנחתו ואלעפיהו
 טוב ונאה אם יאכל ממנו הרבה
 ויהא ויחיו לו כך אלו הענינים
 בתולה לא ידע האדם ותעלתם :

656 Rés.X 1665, f. 12v

PARIS SERVICE PHOTOGRAPHIQUE REPRODUCTION INTERDITE

Transcription of the annotation
 Ces lettres cy sont des precedents 4^e et 5^e lettres des mes ouvrages p(ou)r ledit Maggio.

Translation of the annotation
 These typefaces are the fourth and fifth of my production for the aforementioned Meir (di Parenzo).

Hebrew source:

**Section of page from the 1550 Bragadin edition of the Mishneh Torah; The first book
Sefer Madda, Yesodey haTorah - Chapter 5**

*Lettre de Martin le Jeune de Paris
vulgar lettre mal faicte*

תהלים קיט
הנרה תאבתו לפקודיה בצדקתה
תיני :
ויבאני חסדה יהורה תשועתה
כאמרתה : ואענה הרפי דבר פי
בטחתי ברכה : ואל תצל ספי
דבר אמת טר סאר כי למשפט
יחלתי : ואשמרה תורתך תמיד
לעולם ועד : ואתהלכה ברחבה
כי פקודי דרשתי : ואדבר
בעדתיך נגד מלכים ולא אכוש :
ואשתעשע במצותיה אשר אהבתי :
ואשא כפי אל מצותיה אשר
אהבתי ואשיחה בתקיה :
וכר דבר לעבדך על אשר
יחלתי : ואר נחמתי בעניי כי
אמרתה תינני : ודים הליצוני עד
סאר סתורתך לא נטיתי : ופרתי
משפטיך

Hb39 (S)

86772 Rés X 1665, f. 13

Transcription of the annotation

Lettre de Martin le Jeune de Paris, vieille letter mal faicte.

Translation of the annotation

Typeface of Martin le Jeune of Paris, an old and badly made character.

Hebrew source:

Psalms 119:40-51

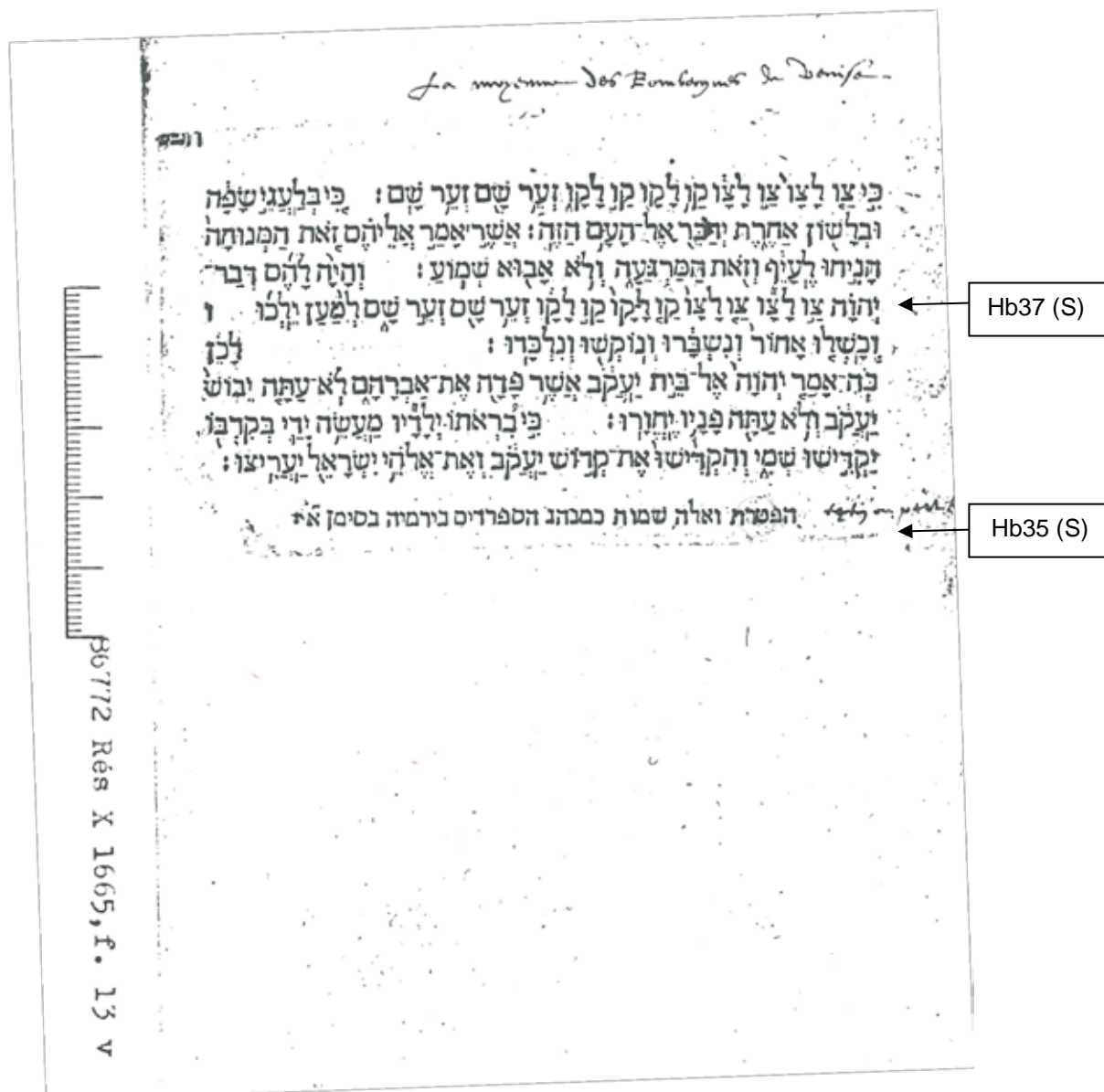

Transcription of the annotation

(Above) *La moyenne des Bombergues de Venise.*

(Below) *Textin ou petit texte*

Translation of the annotation

The Bomberg 'Moyenne' from Venice

The 'textin' or 'Petit Texte'

Hebrew source:

Isaiah 28:10-15

Hb9 (S)

1556
פרקי אבות פרק ה
 א לפנים מישראל: כ עו כנמר הנמר הזה נולד מן חזיר היער והלבויה כי בעת יחס האריות הלבואות
 נכנסת דאשה כסככי היער וכוהמת ויתבעת את הזכר והחזיר שומע קולה ורובעה ונמר יונג מבין שניהן
 ולפי שהוא ממור הוא עו פנים אצט שאין בו גבורה כל כך אף אתה היו עו ולא תתבייש לשאול מרבך: מה
 שלא סבכת כאותה ששנינו לא הכנישן למד: וקל ככשר לחזר אחת למודך ולא תנע כדכתיב ועלו אכר ככשרו
 ידעו ולא ייגעו: ורץ ככבי לרדוף
 אחר המנוות: ועבד כארז לכנוש
 את יונגן מן הענידות: עו פנים
 לפי שהענות ככר בפניו כדכתיב
 העו איש דשע בפניו לפיכך כקרא
 עו פנים: שתכנה עירך במהרת
 בימינו כלומר כשם שמכנתמו וקרא
 המדה שסימן לרוע אכרה בימינו
 דמחוס וגומלי חסדי כן יהי רצון
 שתכנה עירך וכו': כא כן חמש
 שני למקרא מעלה ולפיכך דכתיב
 ג פנים יהיה לכם ערלים וכשנה
 הרביעי יהיה כל פריו קדש קולנו
 שאכינו מלמדו בורת האותנו והכר
 הסקודות וכשנה החמישית שאכלנו
 את פרוי להסוף לכם תבואות
 מכלאן ולאן שפי ליה בתשרה: כן
 למשנה שלמוד מירא השמשות

שני משנה זה שני תלמוד דאמר מור כל תלמוד שלא דאס סימן ופה במשנתו חמש שכי טוב אינו רואה דכתיב
 זאת אשר ללוויים עבן חמש ועשרים שנה ומעלה יבא לבנוא כבא שבא ולמוד הלכות עבודת חמשה עשרים וכן
 שלשים שבד: בן שלש עשרה למנות דכתיב איש או אשה כי יגעו מכל מעולת האדם ונבי שכם כתיב ויחזק
 שני בני יעקב שומעו ולוי אחי דיכה איש חרבו ולוי באותו פרק בן שלשה עשר שנה היה וקרי לוי איש: בן
 שמה עשרה לחופה תשע עשרה אדם כתיב וברשת בראשית מן ויאמר אלדים כעשה אדם עד ויבנה
 אלהים את הנלע חד לגופיה פשו להו שמה עשר לרשא: בן עשרים לרדוף אחר מוונותו לאחר שלמד
 מקרא משנה ותלמוד וכשא אשה והוליד בנים גרין הוא לחזר ולבקש אחר מוונות: פירוש אחר בן עשרים
 לרדוף אותנו מן השמים ולהענישו על מעשיו שאין בית דין שלמעלה מענישים פחות מכן עשרים: בן שלשים
 לכח שהלויים היו תקימין את המשכן ומשרקין ועובדין את העגלו וכושאין בכתף יובן שלשים שנה ומעלה:
 בן ארבעים לביטה שלאחר ארבעים שנה שהיו ישראל כמדבר אחר להם משה ולא נתן להם לב לדעת
 ועינים לראות ואזנים לשמוע עד היום הזה: בן חמשים לענה שאמר בלויים ומכן חמשים שנה ישבו
 מנבא העבודה ולא יעבוד עזר ושרת את אחיו וכו' ומהו השירות שיתן להם עצה: בן ששים לזקנה דכתיב
 תבא ככלם אלי קבר ככלם בגימטריא ששים: בן שבעים לשיבה דכתיב כדוד וימת בשיבה טובה וישו חיות
 היו שבעים שנה: בן שמיים לגבורות דכתיב ואם בגבורות שמוכים שנה: בן תשעים לשוח הוה שמוח וכפוף
 ויש אומרים לשון שוחה עמוקה: ככ השך והשך בה בתורה: דכולה בה שהכל תמונה בה:
 וסיב וכלה בה גס עד זקנה ושיבה לא תעובנה: ושיבה לא תנוע שלא תאמר למדתי חכמת ישראל אלך
 ולאמוד חכמת האומות שאין מותר ללמוד חכמת האומות אלא במקום שאסור להרהר בדברי יקרה כגון
 בבית המרחץ או בבית הכסא: כשאשאלו את רבי יהושע מהו ללמד אדם את בנו ויבית אחר להם ויעבדו
 בשעה שאינו לא יום ולא לילה דהא כתיב והייתו בו יומם ולילה: ככ לפום נערא אגרא פט
 רוב הנער שאתה סובל כלמוד היורה ועשיית המנוות כן יהיה שערך מרובה:

שמיא
 תלמוד א 1546
 מאן הוה פ. ארנסט

Hb5 (R)

Hb40 (S)

BIBL. NAT. 656 Rés. X 1665, f. 14
 BIBL. NAT. 656 Rés. X 1665, f. 14
 SERVICE PHOTOGRAPHIQUE
 SERVICE DE MICROFILMAGE
 REPRODUCTION INTERDITE

Transcription of the annotation

(Above) La glose moyenne q[ue] jay taillee a Venise p(ou)r Maggio, 1556, pour laquelle jeuz un proces cō(n)tre le Justinian.

(Middle) Ce petit texte est de Jehan Picard a (ou de) Paris decedé a Lyons.

(Below) Ceste grose est moy faite 1546 aVenise p(ou)r May de Parense.

Translation of the annotation

The 'Moyenne' gloss which I cut in Venice for Meir (di Parenzo) in 1556, for which I had a court case against (Marco Antonio) Giustiniani.

The petit texte was cut by Jean (Arnoul) Picard of Paris, who died in Lyons.

This gloss was made by me in 1546 for Meir di Parenzo.

Hebrew source

Chapter 5 of the Pirkei Avot

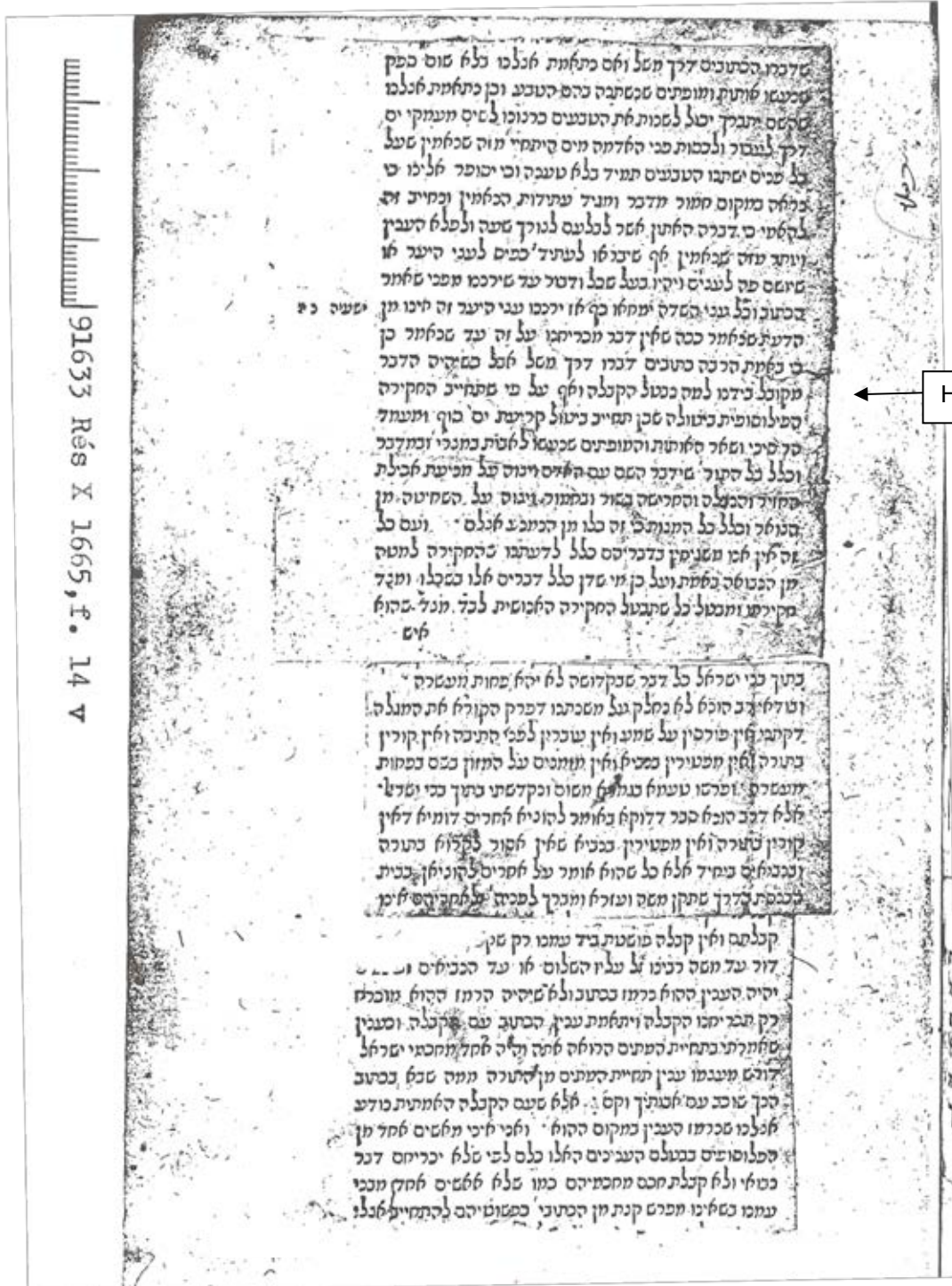

Hebrew source
Commentaries from the Tractate Megillah

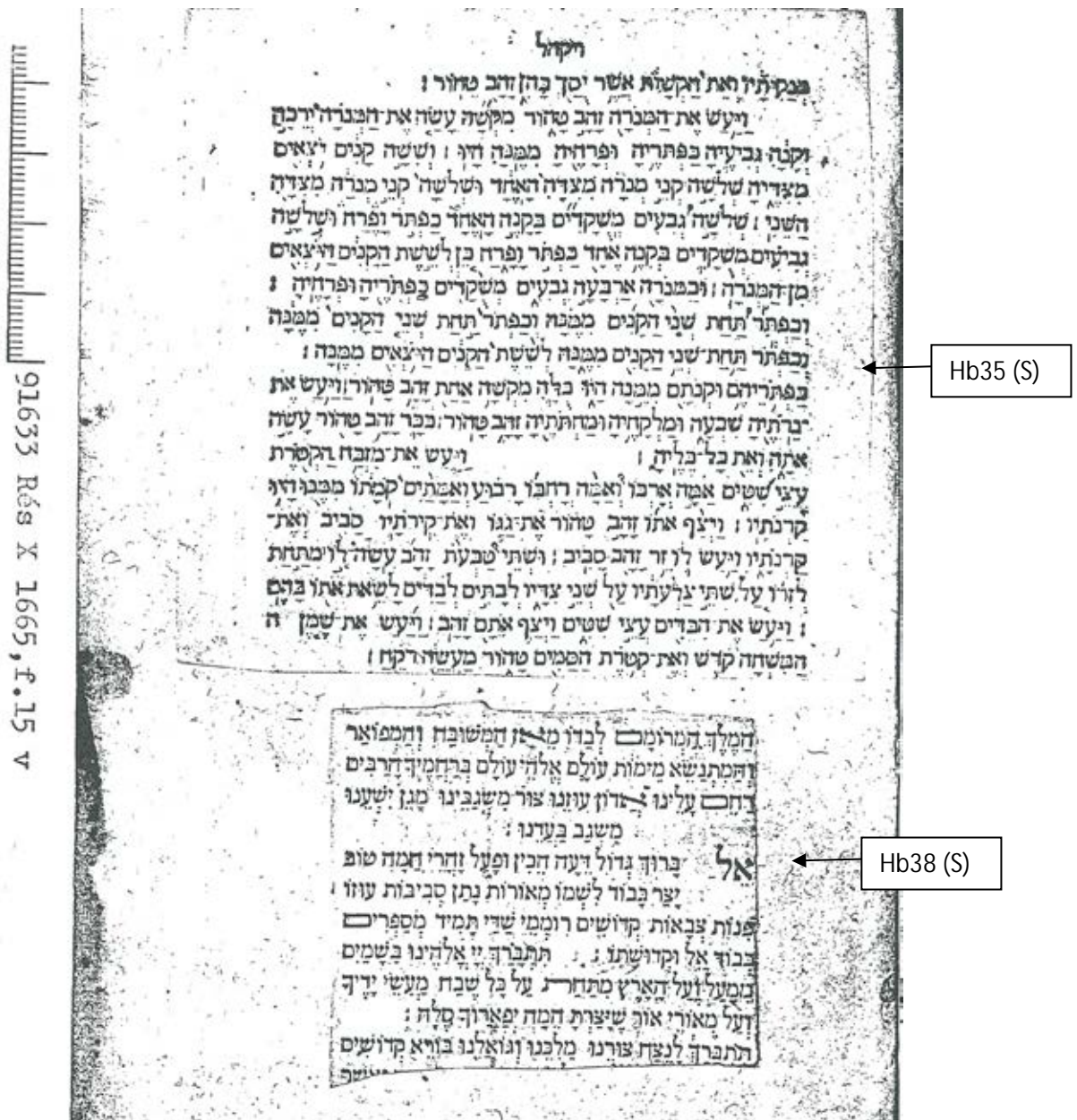

Hebrew source
Exodus 36:17-29 (upper specimen) and Morning Prayers (Shacharit) for the Tzom Gedaliah Fast Day (lower specimen)

רוּת

ותקם ללקט יצו בעז את נערו לאמר גם בין העמרים תלקט ולא
 תכלימה ו גם של תשלך לה מן הצבתים ועזבתם ולקטה ולא
 תנערו בה ותלקט בשדה עד דערב ותחבט את אשר לקטה יהיו
 באיפה שלערים ותשא ותבוא העיר ותרא חמותה את אשר לקטה
 ותוצא ותתן לה את אשר הותרה משכעה ותאמר לה חמותה
 איפה לקטת היום ואנה עשית ידי מבירך ברוך ותגד לחמותה א
 את אשר עשתה עמו ותאמר שם האיש אשר עשיתי עמו היום ב
 בעז ותאמר נעמי לבלתה ברוך הוא ליהוד אשר לא עזב חסדו
 את דחיים ואת המתים ותאמר לה נעמי קרוב לני האיש מגאלג
 הוא ותאמר רות המואביה גם כי אמר אלי עם הנערים אשר לי
 תרפקן עד אם בלוי את כל דקציר אשר לי ותאמר נעמי אל רות
 בלתה טוב בתי כי תצאי עם נערו תיו ולא יפגעוך בכ בשדה אחרו
 ותדבק בנערות בעז ללקט עד כלות קציר השערים וקציר ה
 דחשים ותשב את חמותה ותאמר לה נעמי חמותה בתי הלא א
 אבקש לך מנוח אשר ייטב לך ועתה הלא בעז מועתנני אשר
 היית את נערתי ומה נראה וזה את גרן השערים היללה ורחצת
 נסכת ושמת שמלתך עליך וירדתי גרן אל תודעי לאיש עד כ
 בלתו לאכל ולשתות ויהי בשכבו וידעת את המקום אשר ישכב
 שם ובאת וגלית מרגלתי ושכבתי והוא יגיד לך את אשר תעשין
 ותאמר אליה כל אשר תאמרי אלי אעשה ותגד גרן ותעש
 ככל אשר צותה חמותה ויאכל בעז וישת וישב לבן ובא ל
 לשכב בקצה הערמה ותבא בלש ותגל מרגלתי ותשכב
 ויהי בחצי הלילה ויחרד האיש וילפת
 חצה אשה שכבת מרגלתי ויאמר מי את ותאמר אנכי רות א
 אמתך ופרשת כנפך על אמתך כי נאל אתה ויאמר ברוכה את
 ליהוד בתי היטבת חסדך האחרון מן הראשון לבלתי לכת אחרי

Hb35 (S)

91633 Rés X 1665, f.16

Hebrew source
From Ruth 2 and 3

86712 Rés X 1665, f. 16 v

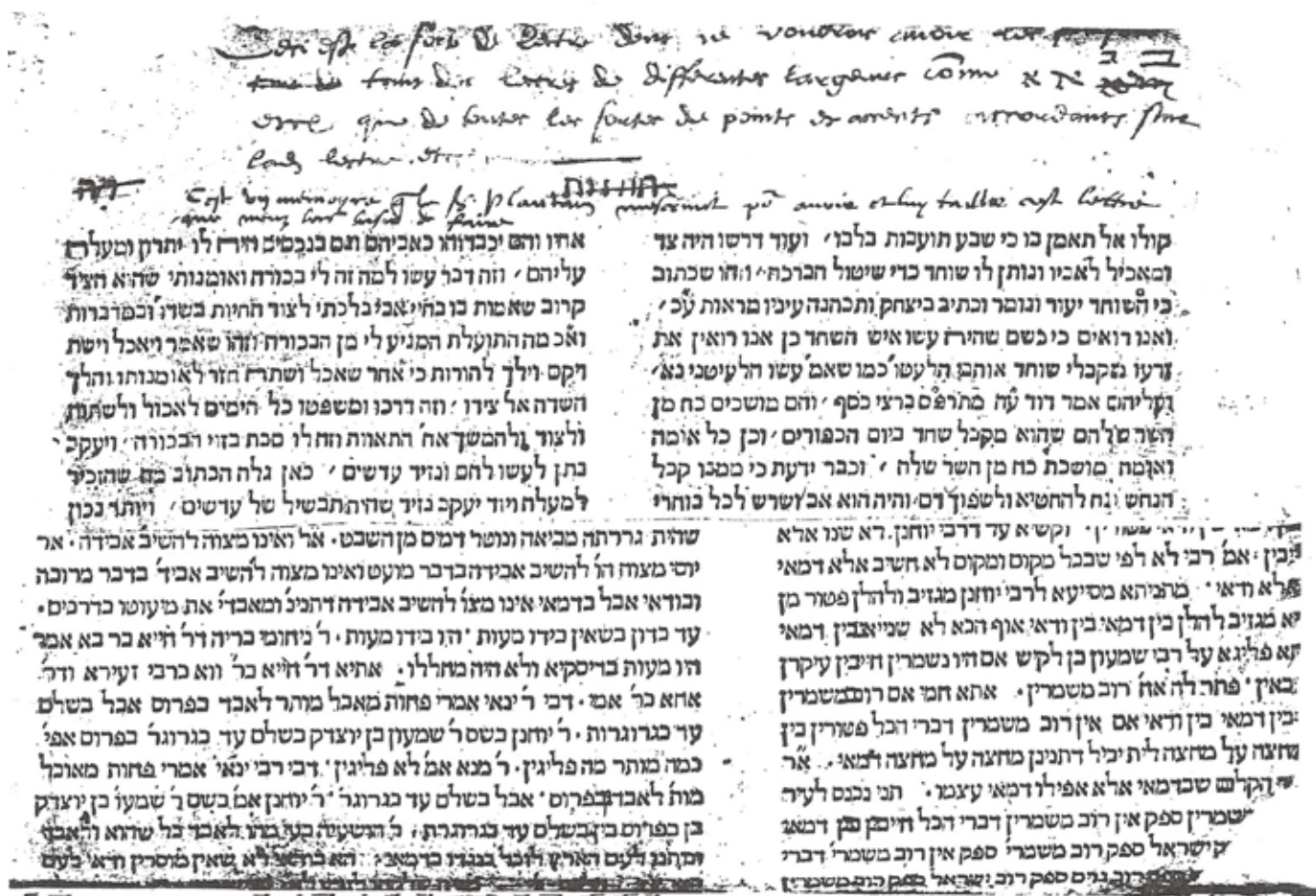

Hb35 (S)

Transcription of the annotation

(In the hand of Christophe Plantin) Ceci est la sorte de letter dont je vouldrois avoir les poinsons, tant les lettres de differentes largeurs, cō(m)me א א ב ב que de toutes les sortes de points et accents accordants sur laditte lettre etc

(In the hand of Guillaume I Le Bé) Cest un memoyre q[ue] le S(ieu)r Plantain mescrivit pour avoir et luy tailler ceste lettre que neuz lors loisir de faire

Translation of the annotation

This is the type of typeface of which I would like to have punches, containing extended characters (א א ב ב) as well as all the types of vowels and accents suitable for these characters.

This is a note from Plantin asking me to cut this typeface, but which I did not have the time to undertake.

Hebrew source

Commentary on Gen. 25: 29-34 from the Ben Asher *Pentateuch* printed by Bomberg in 1546 (upper specimen); Bomberg *Jerusalem Talmud* (lower specimen)

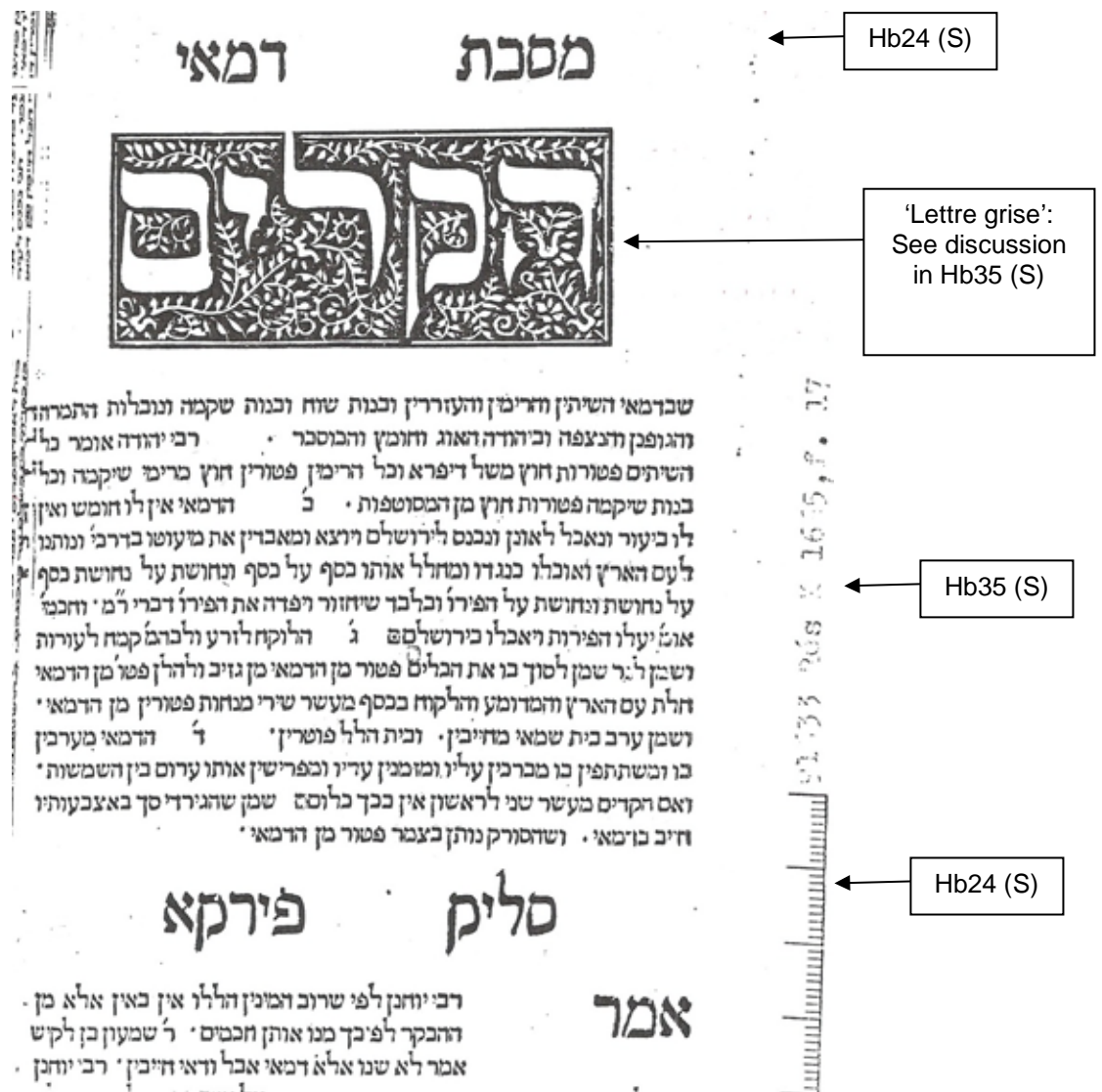

Hebrew source

From the Tractate Demai from the *Jerusalem Talmud* (Talmud Yerushalmi) printed by Daniel Bomberg in Venice in 1523

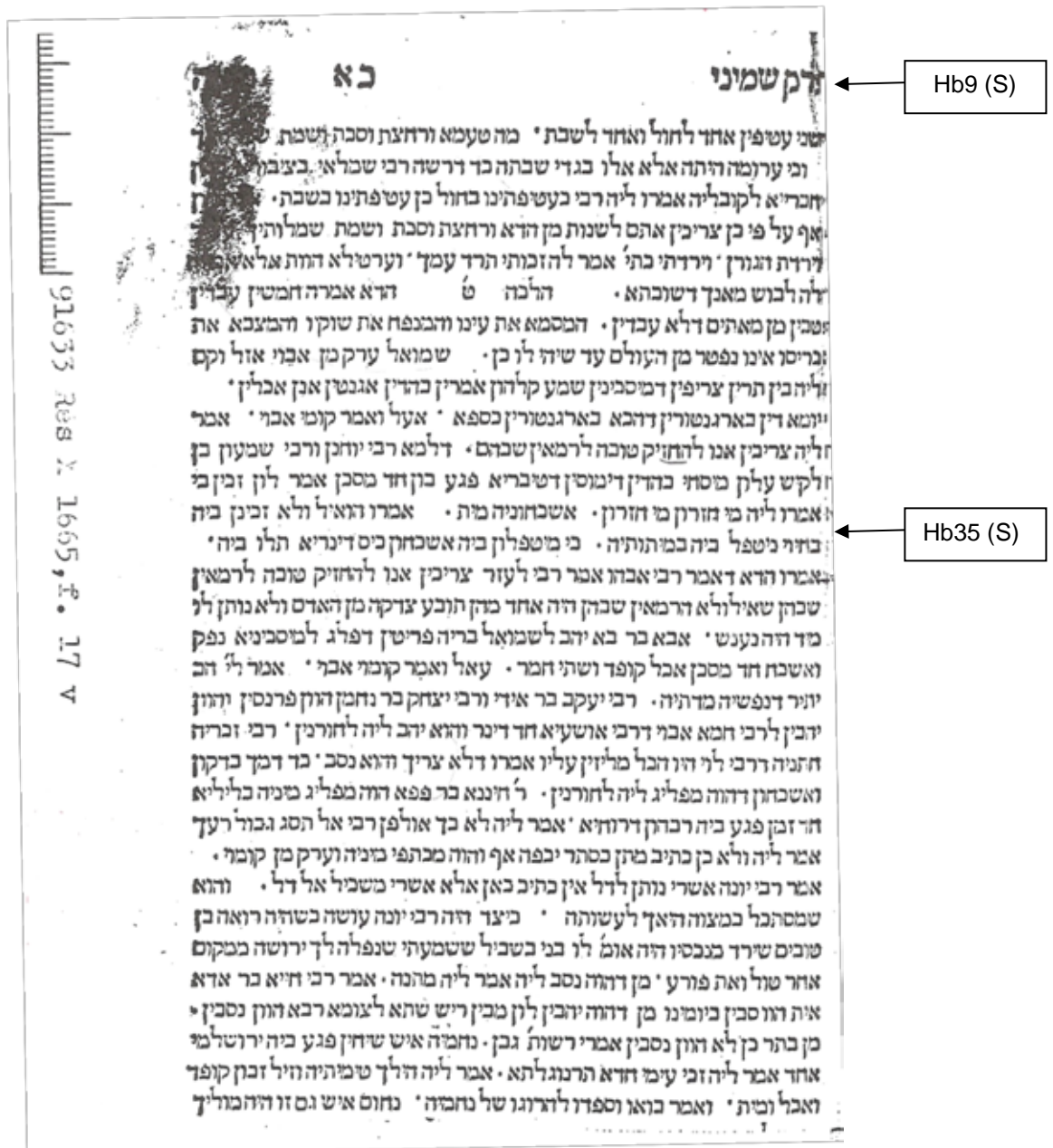

Hebrew source

From the Tractate Demai from the *Jerusalem Talmud* (Talmud Yerushalmi) printed by Daniel Bomberg in Venice in 1523

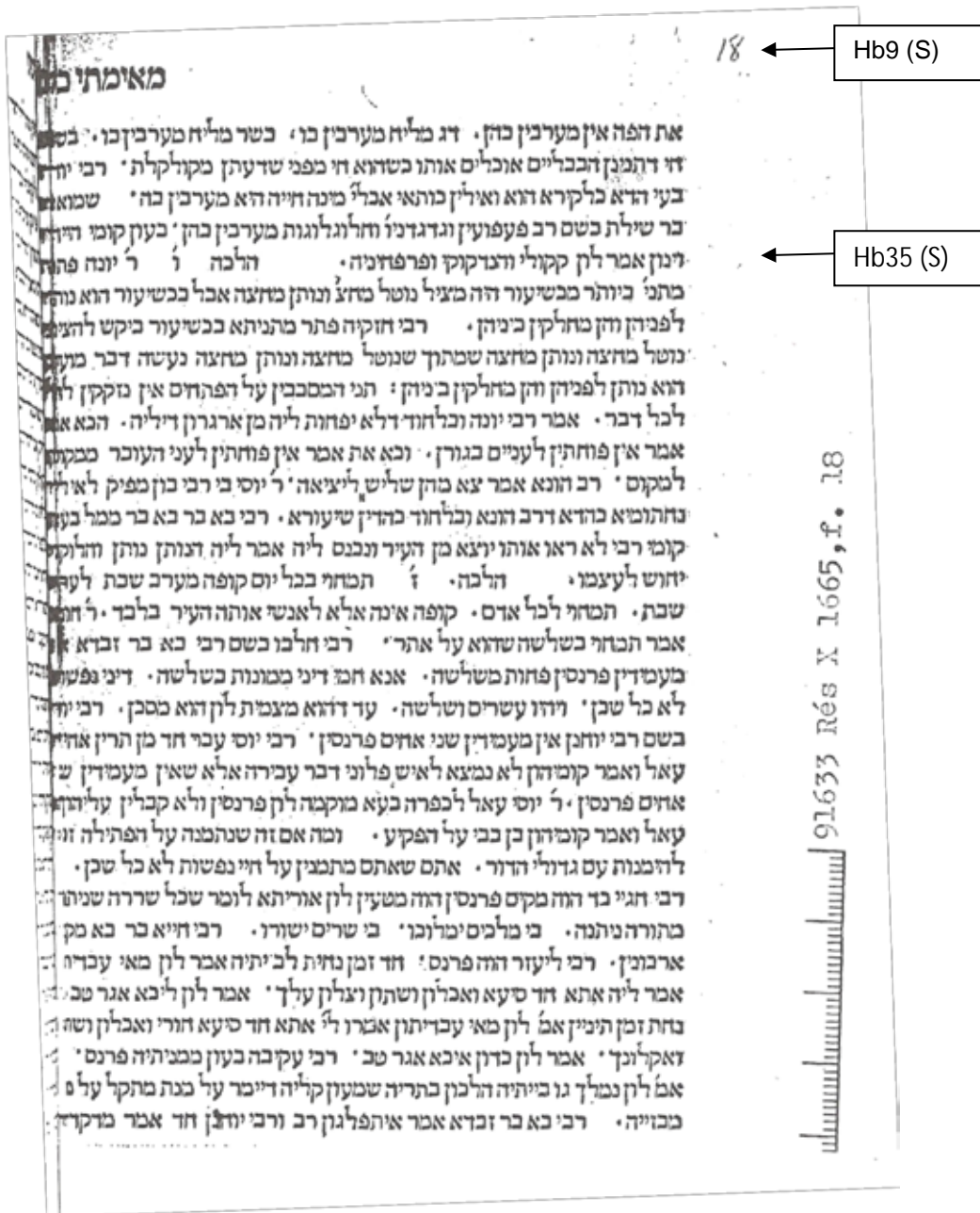

Hebrew source

From the Tractate Demai from the *Jerusalem Talmud* (Talmud Yerushalmi) printed by Daniel Bomberg in Venice in 1523

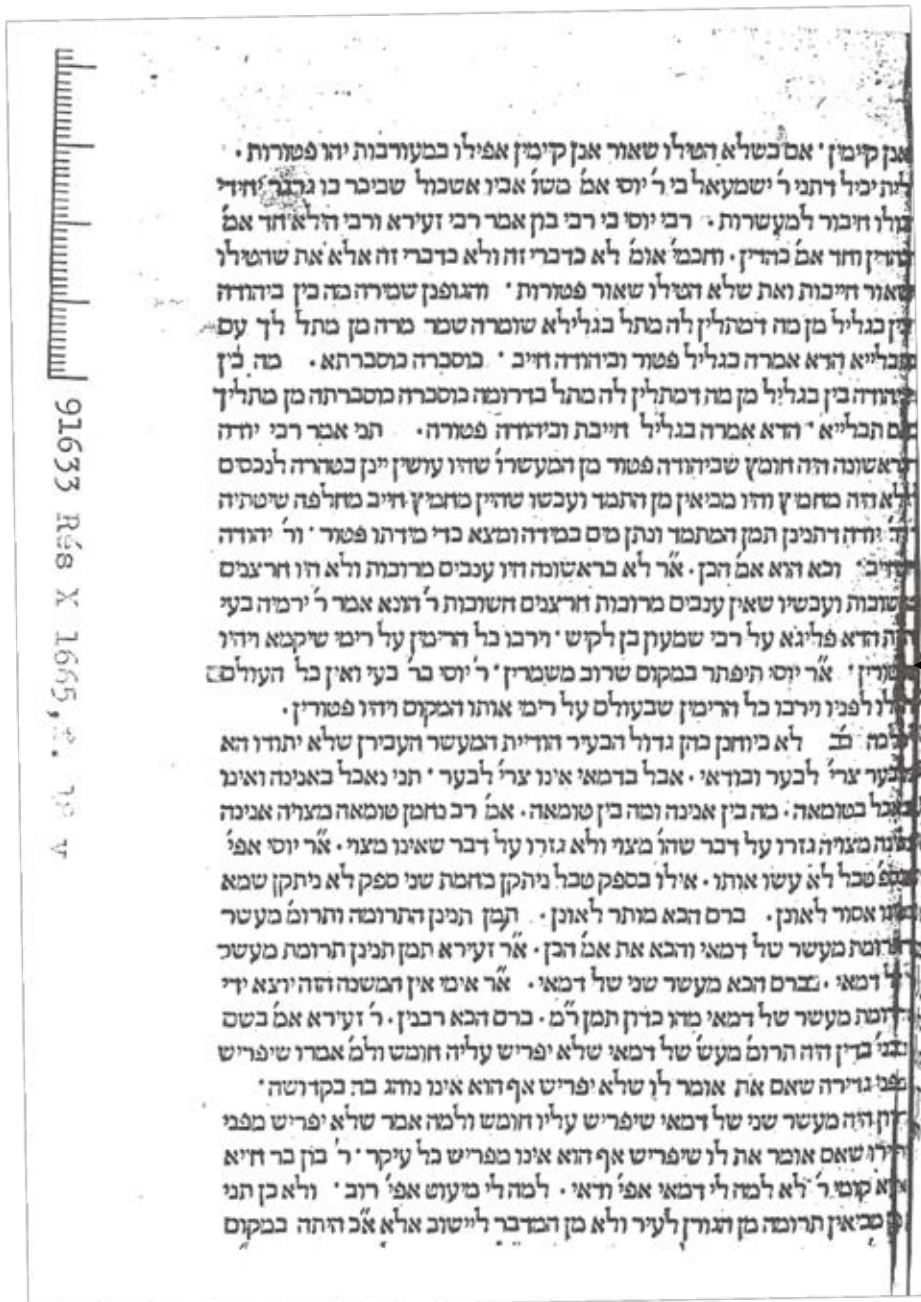

Hebrew source

From the Tractate Demai from the *Jerusalem Talmud* (Talmud Yerushalmi) printed by Daniel Bomberg in Venice in 1523

01633 X 868 1665, f. 19

מן העולם הזה כי הרשעים יעשנו בצרנו וייסורין או במות וכן יעשנו במשפט על מעשי
 כעולם הבא לקץ וזמן אבל אויבי העם המשיח לחלבי הכסבים ושמים זהו נתיב
 נכלה בעשן ולא המשיח לבשר הכרים כי יעשה גלות וישארה האפר על כן אמר
 בעשן בלתי באשר חלבי הכרים כלים בעשן כן יכלו אויבי העם כי תכלה נפשם ותא
 מן העולם הבא ונפוקד עון אבות על בנים על שלמים ועל רשעים וענין שונאי
 במצא לפעמים גם באכזים שהם עגזי המצות וכו' הקרים מכל עבירה במעשה וכלא
 בפשם רעה ובקרב לבם יקצה להם כאשר חבריהם עושים בתור גירע בעיניהם כ
 בני אדם עבדי את השם ויריאים מלפניו כאשר תאמר על האיש אשר לא יחפזן אי
 בני אדם את המלך ואיעבדוהו כי הוא שוכח את המלך כשם האיש הזה מחשבתם הק
 הפעל שהם מניאים את לב בני אדם מעסק התורה ומן המצות כי הם שונאי השם
 האכזים אשר עינם צרה בכבוד תלמידיו חכמים הישרים והצדיקים ושונאים ע
 תפארתם או ירע לבבם אם עדיהם תאקה וכבאה ממאלת הדור וכן כתוב כי לא
 מאסו בי אם אותי מאסו ממלך עליהם וכל שכן אם יבקשו כבודם לכלמה או יא
 וכן אם יאהבו כבוד הרשעים ומשלים יעל עפר כי אלה באמת שונאי השם ואין
 בקיום עבדותו ולא יחפזו בהדרת קדש ויראתו ואשר ירבין מאד עבדיו ויריאי וכן
 המחבלים כרם השם כמו המושארות ומחטיאי הרבים הנה הם שונאי השם כאשר ת
 כי האנשים המשחיתים ערי המלך או כרמיו ופרדשו כי הם שונאי המלך וכן כי כ
 צבאות בית ישראל ובית יהודה נטעשעשו עונו ונ על עמך יערימו בוד וכן כ
 יחדיו עליך ברית יכרותו וכו' ורזונים נשדו יחד על הועל מאימו על כן אזל כי המ
 ושחטאו והחטיאו את הרבים יורדין לביהם וכדונין שם לדורי דורות וכת הנותני
 בארץ חיים דבר עליהם יחזקאל גליו השלום אשר נתנו ח
 בארץ חיים ותהי עונותם על עצמותם למדנו מזה כי לא יכפר עליהם המות אכן
 עולם עונותם על עצמותם ואמרן זל המיכים והמשומדים והאפיקורנים והמ
 ושכפרו בתורה ושכפרו בתחיית המתים ושפרשו מדרכי צבור ושנתנו חתתם בארץ
 כגון הפרנסים המטילין אימה יתירה על הצבור שלא לשם שמים ושחטאו ושחטאו
 הרבים כגון ירבעם בן נבט וחבריו יורדין לביהם וכדונין בה לדורי דורות שכת
 וראו בפברי האכזים הפושעים כי תולעתם לא תמות וכו' וענש הנותנים חתתם
 חיים מחמשה פנים השנים מצד עצמו והשלמה מצד העם השנים שהם מצד עצמו
 כי האנוש רמה ותלעה וכן נקרא גם עור בחיים חיותו ולא דיו שלא ישח ולא יש
 ישתדר גם השתרר שלא לשם שמים וגם במחשבת הבאזה מכלי השתרר נפסד האדם
 תועבת ה' כל גכה לבי והשני כי האדם חייב להבין מערכו לככל עת להאכין
 אימה ויראה מעל פני הש' ועל הרשעים כאמר וכל יאמרן בלבבם כירא בא את ה'
 הנותן חתתו בארץ חיים שלא לשם שמי' אין בלבנו אימה מלפני השם ורונה להטיל
 על כריותיו ותחת שיש לו לערוך מחשבו להאכין אימת השם בלבנו הוא ערוך אותם
 אימת עצמו על עש הש' וכמו של באדם צדיק מושל ויראת אלקים פי' ראוי לקו

Hb44 (R)

Z

Hebrew source

Possibly a text From the Sefer Sha'arei Teshuva by the thirteenth century biblical scholar Yonah ben Abraham Gerondi, also known as Rabbenu Yonah.

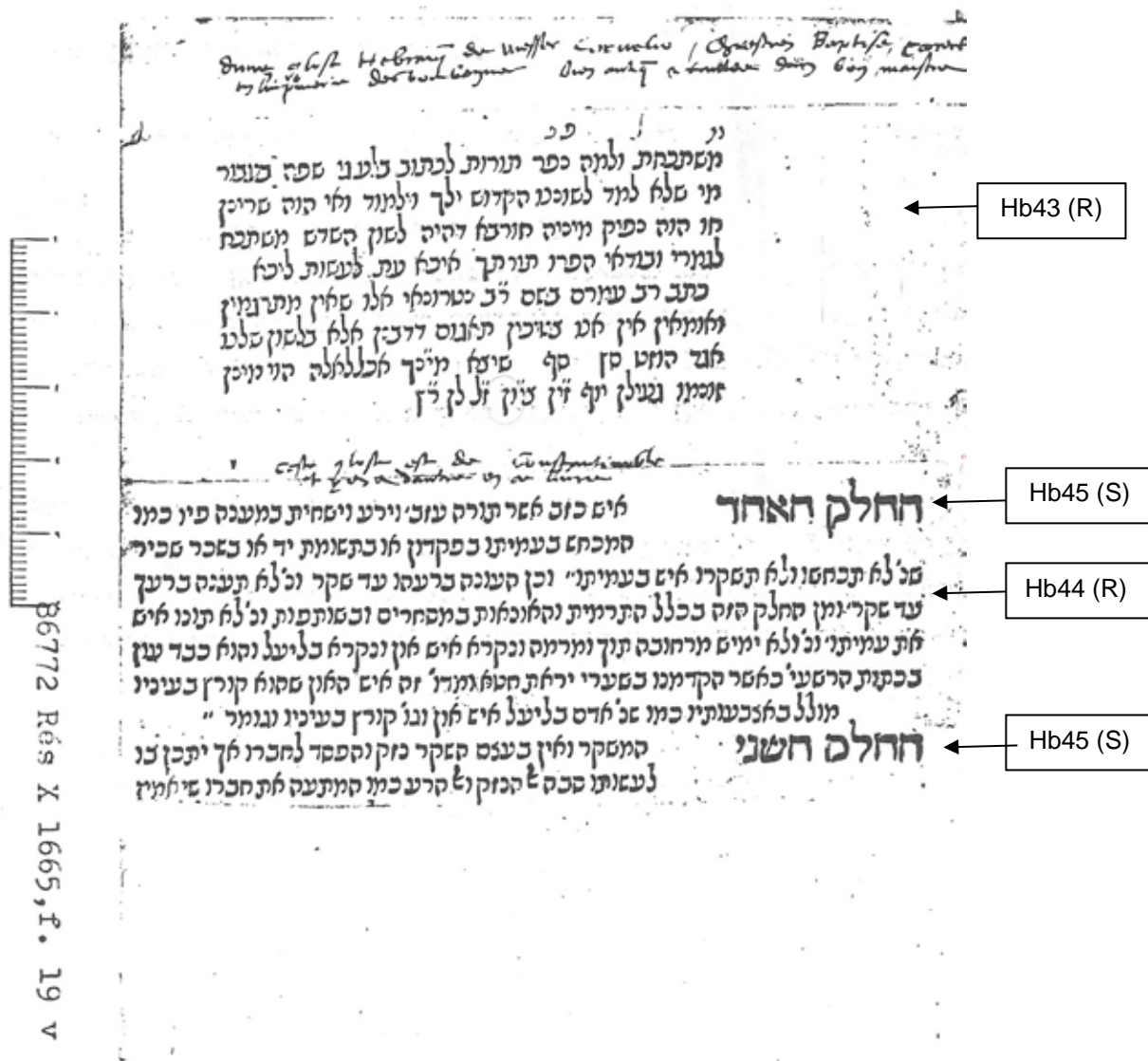

Transcription of the annotation

(Above) dune glose hebraiq(ue) de messer Cornelio / Chretien Baptise, correcteur en limprimerie des Bombergues bien antiq[ue] et taillee dun bon maistre

(Middle) Ceste glose est de Constantinople et y en dautre en ce livre.

Translation of the annotation

A Hebrew gloss for Master Cornelio (Adelkind), a baptised Christian and corrector at the Bomberg press, very old and cut by a skilled master.

This gloss is from Constantinople and there are others in this book (manuscript)

Hebrew source

From the edition of *Sha'arei HaTeshuva* (the Gates of Repentance) by the thirteenth-century Catalan rabbi and moralist Yonah ben Abraham Gerondi, printed by Gershom Soncino in Fano in 1505/6.

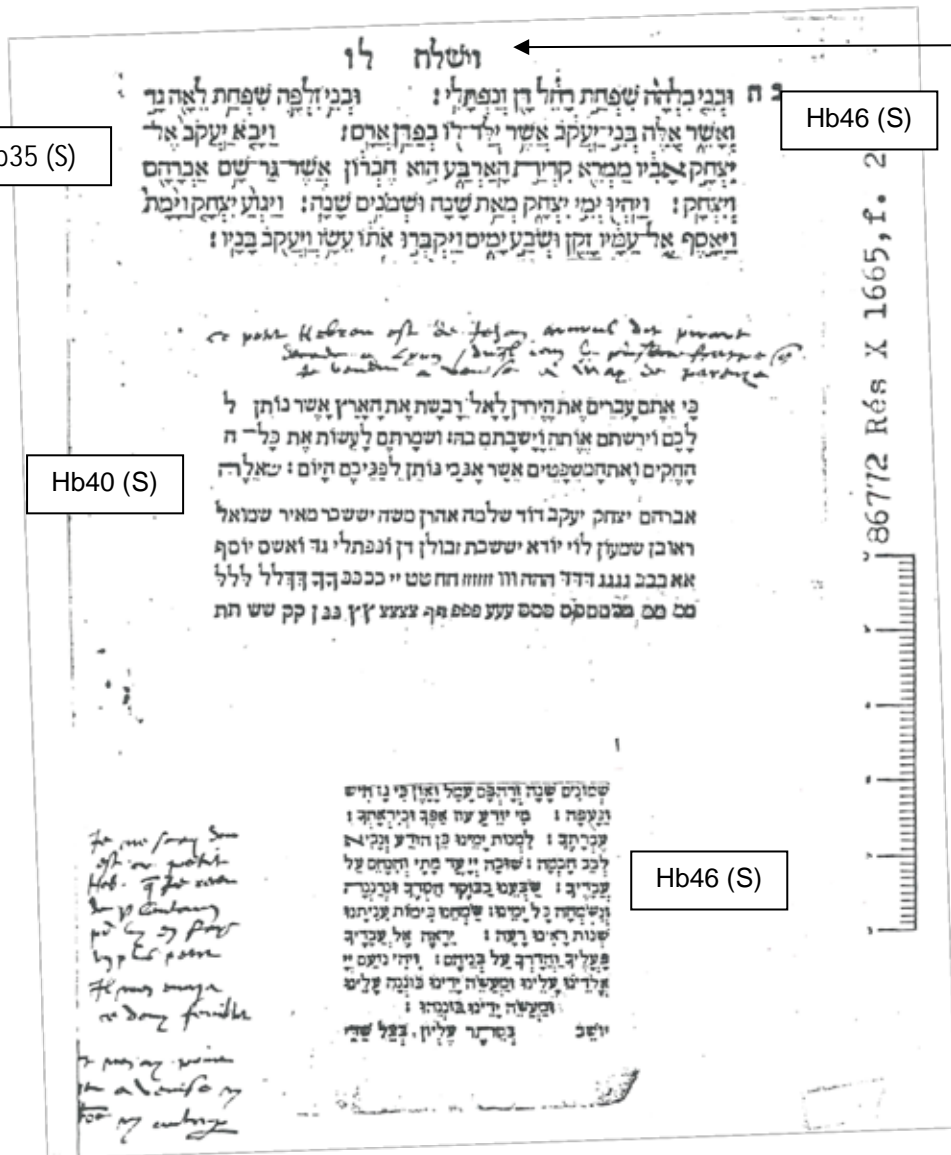

Hb35 (S)

Hb37 (S)

Hb46 (S)

Hb40 (S)

Hb46 (S)



(the reverse side)

Transcription of the annotation

(Middle) Ce petit Hebreu est de Jehan Arnoul, dit Picard, decede a Lyons/ duql jeuz la presente frappe que je vendis a Venise a Maz de Parenza.

(Below) Je ne scay dou est ce petit heb q[ue] je receu de Plantain p(ou)r luy en fayre un plus petit. Il men envoya ce demy feuillet, et nen ay point veu a Venise ny Rom ny autrep[art].

Translation of the annotation

This small Hebrew is by Jean Arnoul, Le Picard, who died in Lyons, and from whom I received these matrices which I sold to Meir di Parenzo in Venice.

I do not know where this small Hebrew is from, which I received from Plantin (as a model) to produce a smaller typeface. He sent me this half sheet and I have not seen anything similar in Venice, Rome or elsewhere.

Hebrew source

Genesis 35: 27 (Top specimen), Deuteronomy 11:31 (Middle specimen), Psalms 34:19-end, followed by Psalms 90-91:1 (Lower specimen)

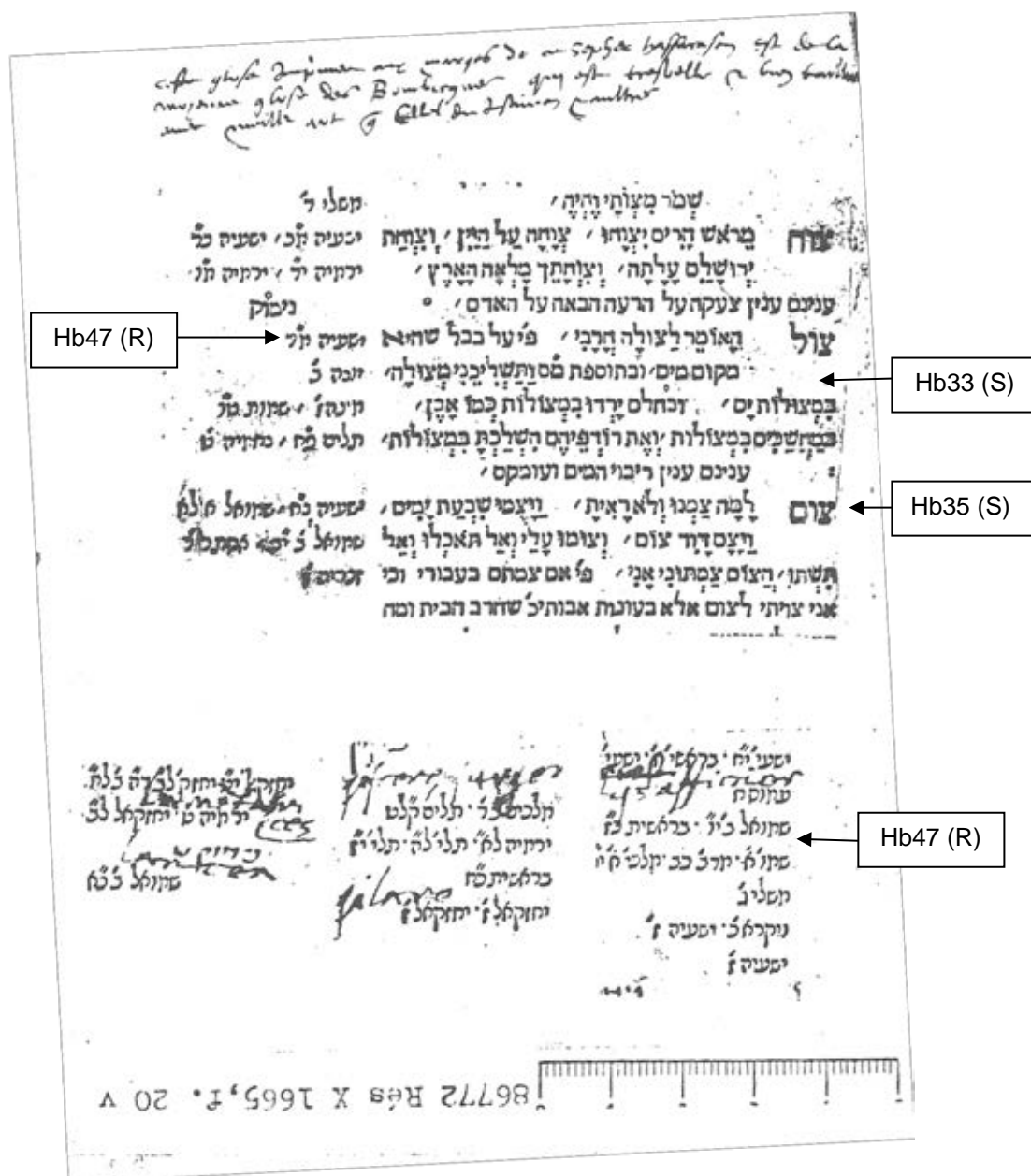

Transcription of the annotation

(Above) Ceste glose imprimee aux marges de ce Sepher Hassarasim est de la moyenne glose des Bombergues. Qui est tres belle et bien taillee, avec meilleurs art q[ue] celles du Justinian et aultres.

(Below) In a different hand and not deciphered. Possibly belongs to a reader's notes.

Translation of the annotation

This printed gloss from the margins of the Sefer HaShorashim is the Bomberg 'Moyenne' gloss. It is very nice and well engraved, done in a better style than those of Giustiniani or others.

Hebrew source

Text from David Kimchi's *Sepher HaShorashim*

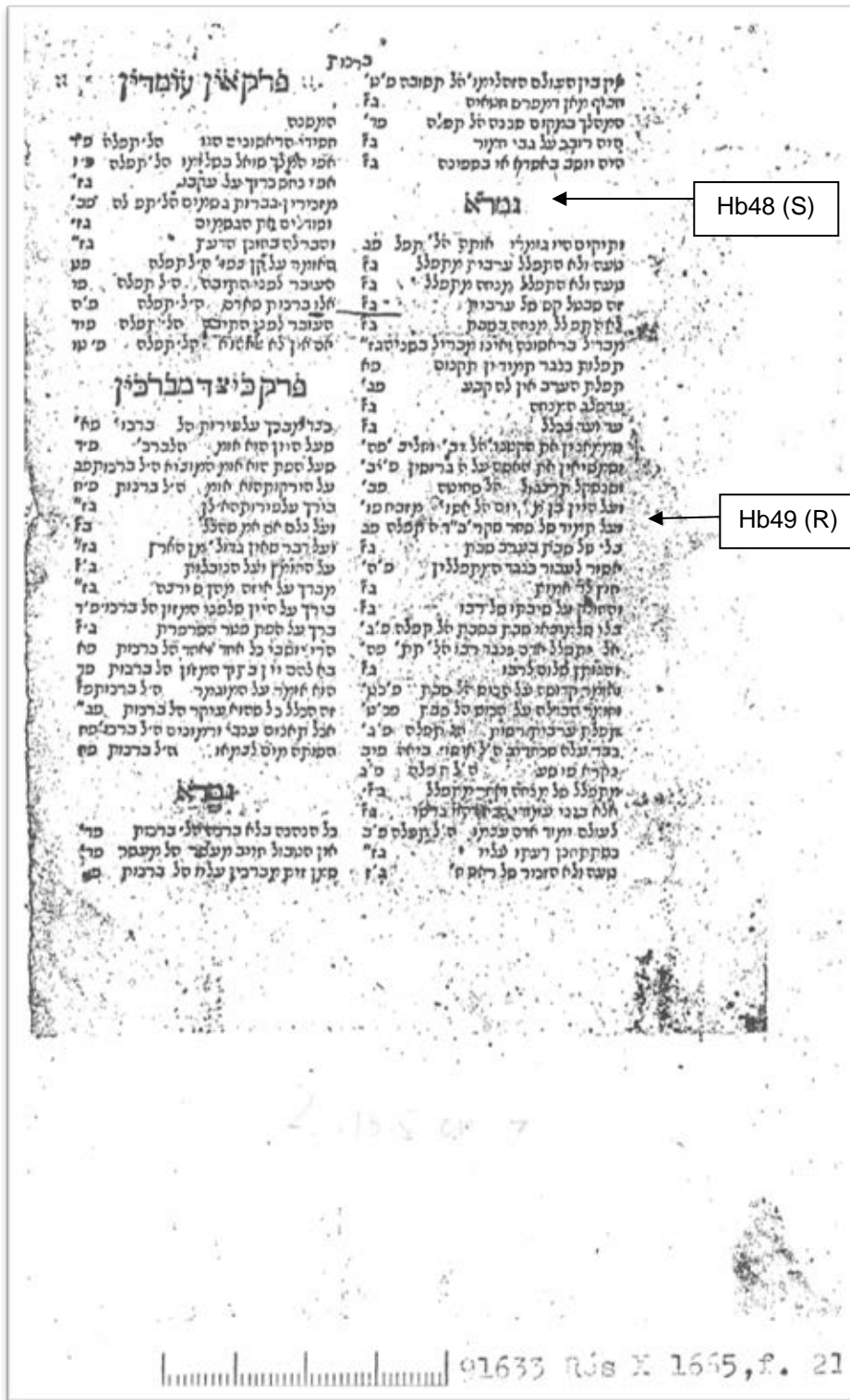

Hebrew source
Text from David Kimchi's *Sepher HaShorashim*

DVPLICANTIA AIN			70
יִסְבְּנוּ	Futurum	סִבְבוּ	
תִּסְבְּנוּ	אִסְבֵּב	סִבַּבְתָּ	
תִּסְבְּבוּ	יִסְבֵּב	סִבְבוֹתַי	← Hb50 (A)
תִּסְבְּבוּ	תִּסְבֵּב	Infinitivus	
תִּסְבְּבוּ	נִסְבֵּב	סִבֹּב	

CONIVGATIO HIPHIL		
מִסְבִּים	חִסְבוּנוּ	Præteritum
מִסְבַּח	חִסַּבְתָּ	חִסַּב
מִסְבוֹת	חִסְבוֹתַי	חִסְבוֹתַי
Paul	חִסְבוֹתֵינוּ	חִסְבוֹתֵינוּ
מוֹסֵב	Benoni	חִסְבוּ
מוֹסְבִים	מִסַּב	חִסְבוֹתֵם

Hebrew source

Page 70 from the 1529 edition of Nicolas Clénard's *Tabula in grammaticen hebraeam*, printed by Theodore Martens in Louvain.

אם תשוב ישראל נאם יהוה אל
 תשוב ואם תסיר שקוציך טפניי
 ולא תוודו שבע תחייהו הבאט
 תבשט טפן ופצוקהוהת פרפופו
 אים ופוי תה לוי יא ערה אחות
 ג ק י ט י א ר פ ת כ ג ק כ ג
 ת ז א א פ ר א צ ז פ צ

← Hb51 (A)

א י נ נ י ו ג פ ל ד ז א כ ו ת פ י ד י נ כ מ
 צ ב ר ת י ה ח מ י ז ו ר ח ו ים ל פ ל י ט
 ז י י ל ע פ י ר ת ת פ א ר ת
 ו ר י א ס ג י א ו ת ט ו כ ו ת י ד מ י ד ו

← Hb52 (A)

ו ק ר י ע ת ז ל ו כ ה ג ז ע ו י ק ו ס ת פ ל ין א מ ס י ט ו ח ו ל ד
 ז ע א מ ס י ע ין כ כ ו ו ז ע ק ה ק ו ל ק ז ה כ ע י ש א ע ל ע ו
 ז ה ת י י ס א ו ת י ק ר ו ט ו א א ח ר ין ח מ ס ל ו א ת ז ע ק י ב
 ו ד א ת ה ל ס כ מ ו ת ע ו כ י ו ט ו כ ה ח ק ו ל ו ט ו כ א ו ח כ ת ל
 נ כ מ ל כ ע א כ ט פ ר א ו ל ג י ק ז ע ק י ב א ח ל ק כ ע ו כ
 ה י כ ו ח ו ע ת ו ר ה ב ל א ש ו ק ב ה ע ז ב ה ז י י ה ז
 ז ע כ ר ס ר ו ו כ ל ק ע י ו כ ע ע י ס ד ו ז ע ז י י ס ה

← Hb53 (A)

Hebrew source

Undetermined Hebrew text and individual characters (Upper specimen), Text from an Ashkenazic Machzor and is a fragment from the *selihah* (To your holy sanctuary our hands are raised) and bottom text is from a fragment of an Ashkenazic selihah for Yom Kippur.

Appendix E: List of archival documents relevant to Guillaume I Le Bé

Source	Date	Notaries or signatories	Details
AdS Venezia Notaio: Marc'Antonio (de) Cavagnis (1543-1595), Atti 193-197 Busta 3251	17 Marzo 1547		Affittanza di Johannes di Juventibus (?) filies (?) Ser Guglielmi de Burgundis impressor librorum C. 78r
Renouard, <i>Documents sur les imprimeurs</i> etc p. 154 AN Y3448 f. 330	Le 3 novembre 1548		'Guillaume Le Bé, papetier à Troyes, saisit une maison à Gentilly sur Claude Duboys, papetier a Paris, pour 411 l. 10 s.t. et 298 l. 18 s.t. en vertu des deux obligations dont l'une souscrite ès foires de Champagne de Brie le 23 décembre 1543'.
AN ET/LVX/161 <i>Inventaire après décès</i> Guillaume Le Be14 Juillet 1598	1548 dattée datte et an, du xxvii eme (27) mil Vc xL viii		Ainsi avec lesquelles estoient deux tiltres nouveaux prisséz de ladite rente, Inventorizé sur lesdits biens deux seulz pour le tout sept - Item, unes lettres de vente du Chatelet de Paris, signée Deprast, dattée datte et an, du xxvii eme (27) mil Vc xL viii (1548) contenant avoir esté adjudgé a Guillaume Lebé une petite maison et lieux assis a Gentilly, comme plus offrant et dernier encherisseur pour la somme de deux cens livres tz estoit le proces verbal de distribution des deniers de ladite vente. Inventorizé sur lesdites lettres de vente, pour le tout huit
AN ET/LVX/161 <i>Inventaire après décès</i> Guillaume Le Be14 Juillet 1598	1551 en datte 30. du xxix eme fevrier (29) fevrier (1552 n.s.?)	Vallet et Crozon	Ung contract dudit Chatellet signé Vallet et Crozon, en datte 30. du xxix eme (29) fevrier mil Vc cinquante ung (1551) contenant Claude Dube marchand papettier a Paris, avoir vendu et promis garantir audit deffunct Guillaume Lebe, ung quartier de vignes ou une piece assise au lieudit les Los Genade au terroir de Gentilly. Et ladite vente avoir esté faicte aux charges et moienant la somme de xxi (21) livres quil en avoit recu ainsi et au dos duquel est la saisine de ce payé. Inventorizé audit dos dix
AN ET/LXXIII/17 Marriage contract	1 ^{er} Mars 1551 (1 ^{er} Mars 1552 n.s.)	?	Furent presens en leurs personnes, honnestes personnes Maistre Nicole Lambert M ^e barbier chirurgien \juré/, bourgeois de Paris et Marguerite Moriset sa femme, de luy aucthorisée en ceste partie, tant en leurs noms que comme stipulans en ceste partie pour Loyse Lambert leur fille a ce presente et de son consentement, dune part/ Et Guillaume Lebé l'aisné marchanf papetier \...../ demeurant a Troyes en Champagne, tant en son nom que comme stipulant en ceste partie pour Guillaume Lebé \le jeune/ aussi papetier demeurant a Paris rue St Jehan de Beauvais, son fils aussi a ce present et de son consentement, dautre (part). Lesquelles parties de leurs bons grez recougnurent et confesserent en la presence et par devant lesdits notaires comme en droict et aussi en la presence de hommes (en marge) avoir faict, feront et font entre eulx et en noms de bonne foy et lune delles avec lautre, les traicte, accordz, douaiere, promesses et obligations que ensuyt, pour raison et a cause du mariage que au plaisir de Dieu sera de brief faict et solempnisé en face de Ste eglise, desdits Guillaume Lebé le jeune et Loyse Lambert, Scavoir est: lesdits xxx Lambert et sa femme avoir promis et

Source	Date	Notaries or signatories	Details
			seront tenuz et promectent bailler et donner par loy et nom de mariage ladite Louyse Lambert leur fille audit Guillaume Lebé le Jeune qui icelle a promis xxxxxxxpromect prendre a sa femme et espouse, de Dieu et notre mere Ste eglise se accordent, incontinent et sitost quil sera advisé entre eulx, leurs parens et amys. En faveur et contemplation duquel mariage et pour a icelluy parvenir, iceulx Lambert et sa fame seront aussi tenuz, promectent et gaigent bailler et payer ausdits futurs espoux dedans le jour des espousailles ou avant icelles, la somme de mil livres tournoiz en deniers contens et en une fois payée, 2. sur laquelle somme ledit futur espoux sera tenu habil[ler 3. et enjoyaullier dhabillemens nuptiaux ladite Loyse Lambert 4. honnestement selon son estat. Et moyenant a ce, ledit 5. futur espoux a doué et doue ladite Loyse Lambert sadite 6. future fame de la somme de quatre cens livres tournois 7. pour une fois payée en douaire prefix, a lever et 8. prendre par elle sitost et incontinent que douaire aura lieu 9. sur la part et portion des biens qui seront et apartiendront aux heritiers dicelluy Guillaume Lebé le jeune, apres son trespas. Et ce apres partages faitz entre elle et lesdits heritiers qui lui sera et demeurera a elle et aux siens de son costé et ligne, a tousjours sans retour/ et de douaire acustume au cheoix dicelle xxx Loise Lambert selon l[es us et coustumes de la ville, prevosté et ... de Paris. Et outre, a esté accordé en faveur dudit futur mariage que ou (= au cas où) icelluy Guillaume Lebé le jeune predecède et vat de vie [a trespas auparavant ladite Loyse sadite future fame, sans enfans dudit mariage vivans lors de son trespas, en ce cas quelle aye et preigne par preciput et adventage tous et chacuns ses habillemens, bagues et joyaulx lors servans a son usage, sans ce quilz soient subjectz a inventaire, partage ne a aucun retour / Et duquel douaire prefix ledit Guillaume Lebé l'ainné a fait son propre fait et debte. Et pour le payement dicelluy, a par les presentes, des a present, obligé et ypothecqué, oblige et ypothecque tous et chacuns ses biens et de ses hoirs et ayans cause presens et advenir . Car ainsi promis fait a Paris .. 2.lan mil Vc Li (1551) le lundy premier jour de mars. (1er mars 1551) 3. Signature
AN ET/LVX/161 <i>Inventaire après décès</i> Guillaume Le Be14 Juillet 1598	1551 du premier mars mil Vc Li (1551) (1552 n.s.)	Chappellan et Arnor	Ung contrat du Chatellet de Paris, signé Chappellan et Arnor en datte du premier mars mil Vc Li (1551) contenant les promesses de mariage faittes, traictées et accordées entre lesdits deffunctz Guillaume Lebé et Loise Lambert jadis sa femme aux conventions et douaire portéz par ledit contrat, inventorié sur icelluy ung
AN ET/LVX/161 <i>Inventaire après décès</i> Guillaume Le Be14 Juillet 1598	1551 en datte du troisieme jour de mars mil Vc cinquante ung (1552 n.s.)	Garnyer et Pechon.	Avec lesquelles lettres estoit les antienes lettres dacquisition de ladite maison faite par Guillaume Lebé laisé, de Marie Racyot en datte du troisieme jour de mars mil Vc cinquante ung (1551), signé Garnyer et Pechon.
Annie Charon <i>Les Métiers du Livre p.</i>	18.7.1551	ET/LXXIII/17	Guillaume le Bé est rentré en France au moins avant le 18 Juillet 1551, date à laquelle il prend en location un

Source	Date	Notaries or signatories	Details
66			<p>ouvroir repondant sur les rues Saint Jean de Beauvais et Saint Jean de Latran .. moyennant 50 lt par an. Also named in this document is Jacques Glanne, Maitre patisssier/ Bourgeois de Paris Le Bé is described as Papetier (Marchand) and Imprimeur Libraire, Paris</p> <p>Honneste homme Jacques Glanne M^o paticier bourgeois de Paris confesse avoir ballé et delaissé a tiltre de loyer dargent, du jour St Remy prochain venant, jusques a quatre ans prochains apres ensuyvans, finiz et accompez et promet garentir dans ledit temps a Guillaume le Bé le jeune, marchant papetier \imprimeur/libraire demeurant a Paris, a ce present, prendre audict tiltre pour luy ses hoirs, ung ouvreiroir (atelier) respondant sur les rues St Jehan de Beauvais et St Jehan de Latran, salette derrier, dans dessoubz ledit ouvreiroir et sallette, avec la premiere chambre estant au dessus desdits ouvreiroir et sallette et faisans pour trois dune maison, assize en ladite rue St Jehan de Beauvais que ledit bailleur tient de dame Marye Racyne. De plus ample declaration, ledit preneur sest tenu pour conten, pour en jouyr, etc... Cestz bail et prinse faitcz, audit tiltre, moyennant la somme de cinquante livres tournoiz que de loyer, pour et par chacune desdites quatre années. Ledit preneur en promet et gaige rendre, bailler et payer audit bailleur ou au porteur. Aux quatre termes a Paris accoustumés, premier terme de payement escheant au jour de noel prochain venant et continuer etc.. Lesquelz biens bailléz, ledit preneur promet attenir de toutes menues reparations, aux us et coustumes de Paris et les garnir de biens meubles exploitables pour seuretté dudit loyer, sortissant nature dicelluy. Et ne pourra bailler ne esporter son droict sans le consentement dudit bailleur qui au surplus le tiendra cloz et couvert ausdits us et coustumes. Et en ce faisant, nestre accordé que ou ledit bailleur estoyt contrainct vuyder de ladite maison suyvant la clause contenue au bail quy faitz ainsy a esté dicelle par ladite Racyne. en ce cas ledit preneur sera aussy tenu vuyder dudit lieu de present baille . Len advertissant toutesfoys troys moys devant et sans autre sommation ne signification de vuyder luy faire, ne autre solempnité de justice y garder ne observer et sans pover par luy pretendre ne demander aucungs dommaiges et interestz. Et neantmoins poura ledit bailleur contraindre en veu du dit present bail a luy payer ce qui pouroyt encores devoir a cause dudit louage. Car ainsy etc... Prometans etc.. Obligeans chacun en droict soy, etc... Renoncans etc... Faict et passé double, lan mil cinq cens cinquante et ung, le samedy dix huictiesme jour de juillet.</p>
Minutier Central via Annie Charon	10 novembre 1551	ET/LXXIII/045	Guillaume Le Bé is named as a Libraire/Paris in a document concerning an apprenticeship for a Libraire for Jacques Asselin.
Archives nationales ET/LXXIII/17 (GG-C)	1er mars 1552		Guillaume Le Bé, libraire, graveur, papetier fils de G. Le Bé l'ainé, papetier jure Mariage le Loyse, fille de N. Lambert (maitre barbier

Source	Date	Notaries or signatories	Details
(cité par A. Parent, <i>Les métiers du livre</i> , p. 194-195)?			chirurgien, bourgeois de Paris)
Renouard, <i>Documents sur les imprimeurs</i> etc p. 154 AN: S. 1652, fo. 22 verso, 3e série. See also SM's notes in CU Library.	15 mars 1552 (n.st.) selon Genevieve Guilleminot (Email)		Guillaume Le Bé l'ainé, papetier, bourgeois de Troyes, achète de Marie Racyne, veuve de Pierre Alexandre, grenetier (au grenier-à-sel) de Paris, pour 3,050 l.t. deux maisons contiguës, rue Saint-Jean-de Beauvais. l'une faisant le coin de la rue Saint-Jean-de-Latran, tenant par derrière à M. le Cirier, à cause de sa femme. NB Grenetier= nm celui qui commercialise des semences, des graines, organes provenant de végétaux et aptes à germer
Annie Charon <i>Les Métiers du Livre</i> p. 66	28.6.1552 (n.s.)	ET/LXXIII/18	Honneste personne Guillaume le Bé marchand papetier demeurant a Paris rue St Jehan de Beauvais, confesse avoir baillé et delaisé a tiltre de loyer dargent, du jour St Remy prochain venant jusques a huit ans et demy prochains apres ensuivans finiz. Et promet garentir dans ledit temps, a Simon Calvarin? marchand libraire demeurant a Paris, a ce present, prenant audit tiltre pour luy, ses heoirs, c'est ledit temps durant le deuxiesme corps dhostel de la maison ou ledit bailleur est demeurant, assise en ladite rue St Jehan de Beauvais, estant au dessoubz de celuy faisant le coing de ladite rue St Jehan de Beauvais et de la rue St Jehan/ de Latran. Ledit demy corps dhostel, comme il se comporte, de fons en comble, sans en aucune chose excepter - fors et reservé la premiere chambre dudit corps dhostel de premier bailh que ledit bailleur a reservée a luy - pour en joyr par ledit preneur audit tiltre, ledit temps durant. Cestz bail et prinse, audit tiltre faictz, moyennant la somme de quarante cinq livres tornois que deloyer par chacun an, durant ledit temps. Ledit preneur promet et gaige rendre, bailler et payer audit bailleur en argent et aux quatres termes a Paris acoustumés. Premier terme de payement escheant au jour de noel prochain venant et continuer . Et garnira ledit preneur, ledit bien baillé, de biens meubles exploitables sortissans nature dudit loyer, pour la seureté dicelluy et lentreten sera de menues reparations. Et ainsi plus, ledit bailleur le tiendra cloz et couvert aux us et costumes de Paris/ Et ne pora ledit preneur bailler ni exporter son droict a autre, sans le consentement dudit bailleur. Et sera la moictiée et premier h.... dicelle, servant ausdits deux corps dhostelz, commune entre lesdits bailleur et preneurs et cetz gens. Aussi sera tenu ledit preneur laisser avaller (faire descendre) par la trappe estant en louverouer dudit corps dhostel du premier bailh, tout ce que ledit bailleur voudra descendre et faire avaller en sa cave, estant audit premier corps dhostel. Ensemble tout ce quil voudra faire lyvrer de sadite cave, a toutesfois comme bon luy semblera. Car ainsin promettent lesdites parties de ce faire. Renoncant. Fait et passé double, lan mil Vc Lii (1552) le lundi xxviiiie (28eme) jour de juing.
Pichon and Vicairé 1895, <i>Documents pour servir à l'histoire des libraires à Paris</i>	5 Juin 1556	Inventaire après deces de Marguerite la Porte, femme de Sire Gaudefroy Roussel,	Lists Guillaume Le Bé as one of several libraires "qui etoient ses debiteurs lors du deces de sa femme en 1556" For 118s. 6.

Source	Date	Notaries or signatories	Details
Archive de Contesse, Notaire		apothicaire, bourgeois de Paris	
Pichon and Vicaire 1895, <i>Documents pour servir à l'histoire des libraires à Paris</i> Archive de Cothereau, Notaire	12 Octobre 1558	Arch de Cothereau, notaire	Bill of sale Mentions Henri Le Bé, libraire demeurant rue des Sept-Voies pres S. Hilaire enseigne du Griffon Blanc and Jehan (Jean) Le Bé marchand hostelier
Annie Charon <i>Les Métiers du Livre</i> p. 66	29.6.1560	ET/LXXIII/25	<p>Guillaume Le be, le jeune, papetier, bourgeois de Paris, loue a son pere Guillaume le Be, aine, deux corps d'hotel et deux ouvroirs dans la maison ou il demeure au coin des rues Saint Jean de Beauvais et Saint Jean de Latran</p> <p>Honorable homme Guillaume le Bé le jeune, marchand papettier, bourgeois de ceste ville de Paris, demurant en la maison cy apres decrite, confesse avoir prins et retenu a tiltre de loyer dargent – de honeste homme Sire Guillaume le Bé laisné, marchand papettier juré, cy de Paris, demurant a Troyes en Champagne, son pere absent, les notaires au Chatelet de Paris soubzsigné, stipullant et acceptans pour luy - du jour de Pasques prochain venant, que lon comptera mil Vc soixante et ung, jusques a neuf ans prochains apres ensuivans, fins et accomplys, une maison contenant deux corps d'hotel entretenans et joignans lun a lautre et deux ouvroirs (ateliers)ans sur rue, le lieu comme il se comporte, de fondz en comble, assis en ceste dite ville de Paris, et faisant un des coings de la rue St Jehan de Latran, en laquelle ledit Guillaume Lebé le . jeune est de present demurant, comme dict est. Ceste . prise ainsi faicte moyenant la somme de cent dix livres tournois que de loyer, pour et par chacune desdits neuf ans. Ledit preneur en promect bailler et paier a sondit pere et aporter aux quatre termes a Paris acoustumés. Premier terme de paiement escheant au jour Saint Jehan Baptiste de ladite année mil . Vc soixante et ung. Et continuer de ladite année ledit paiement par chacune desdites neuf années, ausdits quatre termes. Laquelle maison et corps d'hotel, ledit preneur sera tenu entretenir de menues reparations et sondit pere des grosses. Le tout aux us et costume de Paris Obligent etc.. Renoncent etc.. Faict et passé Lan mil cinq cens soixante, le sabmedy xxix (29) et penultieme jour de juing. Le tout 9. selon et ainsi que déclaré par le bail que luy \a/ faict sondit père de ladite maison, passé audit Troyes par Sr Bartelamy Balesauls et Jehan Cystan notaires audit Troyes, en datte du xxe (20e) jour de jung vc Lx (560).</p>
AN ET/LVX/161 <i>Inventaire après décès</i> Guillaume Le Bé le 14 Juillet 1598	1561 en date du huitiesme jour de septembre m Vc Li (1561)	Baretton	Unes (au pluriel = une paire, deux) lettres faictes soubz le scel de la ville de Paris, signées Baretton, en date du huitiesme jour de septembre m Vc Li (1561) par Lesquelles le Sr Noel Lebé marchand drapier demurant audit Troies avoyt baillé et transporté par tiltre deschange et audit defunct Guillaume Lebé, la moitié divisée dune maison, droictz, aisances et appartenances dicelle, comme elle se poursuit et comporte, assise a Paris Rue de Beauvais, faisant le coing de ladite rue et de la rue St Jehan de Latran *

Source	Date	Notaries or signatories	Details
			(Dans le quartier de la Sorbonne. correspond à l'actuelle rue des Ecoles) dont lautre moitié apartenoit audit deffunct Guillaume Lebé par la succession de feu son pere, ainsi que le tout est plus au long conté audites lettres, inventoriéz sur icelles trois
From SM's notes in CU Library And James Mosley list February 2011 See also Renouard, <i>Documents sur les imprimeurs</i> etc p. 105 Mentionné dans Bib. Nat. Ms Fr 22117	18 novembre 1561		Le Bé, Jean le Sueur drew up the inventory of Garamond's foundry, of which André Wechel was the executor. Plantin bought the matrices and moulds; Wechel bought the punches; Le Bé had a strike from some punches unspecified, before he sold them to Wechel. Also he had other punches from the widow Garamond. 8. Inventory of the foundry of Claude Garamond 1561 Jean-Pierre Fournier wrote, 'J'ai entre les mains cet inventaire en original'. ('Lettre de M. Fournier, l'ainé', <i>Mercur de France</i> , mai 1756, p. 123). This is his description of the document: L'inventaire, la prisée & la vente que Guillaume le Bé & Jean le Sueur, autre fondeur de caracteres, firent de la fonderie de Garamond après son décès, le 18 Novembre 1561, à la Requête de Dame Isabeau Lefevre, veuve de feu sieur Claude Garamond, en son vivant, Graveur de lettres, & Maître à Paris, & de sieur André Wechel, Marchand Libraire, Juré au-dit lieu, executeurs du Testament dudit défunt. Location of original: unknown.
Pichon and Vicaire 1895, <i>Documents pour servir à l'histoire des libraires à Paris</i>	20 janvier 1563	Arch de Brûlé, notaire	Henry Le Bé, libraire, Jehan d'Aumale, aussi Libraire, a cause de Geneviève le Bé, sa femme. Première acquisition par Pierre Le Bé, leur père le 24 mars 1506-1507 de 57 arpens de terre a Villeras arpens: Formerly, a measure of land in France, varying in different parts of the country. The arpent of Paris was 4,088 sq. yards, or nearly five sixths of an English acre. The woodland arpent was about 1 acre, 1 rood, 1 perch, English. <i>villeras (91190)</i> in department Essonne (91) of region Ile-de-France in Franc
Renouard, <i>Documents sur les imprimeurs</i> etc p. 94 Arch Nat. Y3464, fo. 691, and Y3465, fo. 219	16 Mars 1564 (n.st)		La veuve et les héritiers de Galliot Du Pre (libraire) poursuivent les vente et criée d'une maison sise rue Mouffetard, et de deux maisons ru Coippeaulx ayant appartenu a Charles Estienne (Guillaume Le Bé (fondeur) is mentioned as a créancier of Charles Estienne, among others.
[Archives nationales, MC étude LXXIII, 58] Genevieve Guillemot Chrétien/BNF	8 avril 1564		Jehan Anastaze, demeurant chez Guillaume Le Bé, rue Saint Jean de Beauvais, ...bourgeois de Genève, à cause de Jeanne Estienne sa femme, vend à Robert (II) Estienne... le 1/5 de l'imprimerie, matrices, caractères, presses, figures, moules... déclarés en l'inventaire dont la délivrance a été obtenue de Vascosan, par arrêt de la cour, ... moyennant le prix auquel elle a été estimée ily a huit jours par Oudin Petit et Charles Périer, Guillaume Le Bé et J. Le Sueur...
Genevieve Guillemot Chrétien/BNF	16 mars 1565	Guillaume Le Bé créancier de Charles	(P. Renouard, <i>Documents sur les imprimeurs...</i> 1901, p. 95)

Source	Date	Notaries or signatories	Details
		Estienne	
[Renouard, Documents manuscrits, Réserve des livres rares] Genevieve Guilleminot Chrétien/BNF (Archives nationales, X1A 1622, f. 59 v°)	2 janvier 1568		Guillaume le Bey (<i>sic</i>) marchand, bourgeois de Paris [fondeur de lettres] contre Charles Estienne, appelant d'une sentence des juges et consuls des marchands
AN ET/LVX/161 <i>Inventaire après décès</i> Guillaume Le Bé le 14 Juillet 1598	1568 En datte du septiesme jour de mars mil Vc Lx viii (1568)	Chappellain et Chappellain	Unes (au pluriel = une paire) lettres dudit Chatellet signée Chappellain et Chappellain, en datte du septiesme jour de mars mil Vc Lx viii (1568) par lesquelles Sr Jacques Marchant, marchand bourgeois de Paris et Ysabeau le Fevre sa femme, auroit vendu, constitué et promis garantir, paier et continuer chacun pour le tout, sans division, audit deffunct Guillaume Lebe, vingt livres tz de rente sur les heritages et biens, soubz la faculté de rachat et moienant la somme de iic x (210) livres tz quilz en auroient lors receu dudit deffunct.
AN ET/LVX/161 <i>Inventaire après décès</i> Guillaume Le Bé le 14 Juillet 1598	1569 en datte du xxvi eme (26) jour de 19. fevrier mil Vc soixante neuf	Chappellain et Chappellain	Ung contract du Chatellet de Paris, en datte du xxvi eme (26) jour de fevrier mil Vc soixante neuf (1569), signé Chappellain et Chappellain contenant, Noel Darthins marchand demeurant a Gentilly avoir vendu et promis garantir audit deffunct Guillaume Lebé une maison ainsi quelle se comportoit, assise audit Gentilly au lieudit le Clos Benilde . Ung petit jardin et vigne contenant deux quartes xxx ou environ, joignant ladite maison xxxx et ung demi arpent de vignes assis derrier ledit jardin. Et ladite vente avoir esté faicte aux charges et moienant la somme de deux cens huit livres deux solz quil en avoit recu dudit deffunct, ainsi quil est escript audit contract. Inventoriez sur icelluy neuf
Renouard, <i>Imprimeurs parisiens</i> 1898 p. 217	1571		Guillaume Le Bé taxé à 4 livres (No document cited)
AN, ET/CXXII/39	8 June 1571		Marriage contract of Charles Perier Cited by Barbara Diefendorf The marriage contract is in the minutier central of the AN, CXXII 39 (8 June 1571). It is a contract between Charles Perier, marchand libraire et imprimeur, bourgeois de Paris, on behalf of his daughter Marie Perier, and Guillaume Aubray, also a libraire, living in Paris, the son of Guillaume Aubray, living in Normandy, who gives permission for the wedding. The promise to marry "en sainte eglise" follows recognizably Protestant formulas, and the dowry arrangements (which I won't give you in detail) basically turn Perier's properties and merchandise in his house and shop on the rue St. Jean de Beauvais over to Aubray, reserving just a room for himself, with an estimated value at 1073 livres, in exchange for Aubray's promise to pay the money owed to several people. The first listed is "Guillaume Le Be, marchand pappetier a Paris," whom he owes 80 livres. The second is [Mamert?] "Patisson, correcteur en la maison de feu Robert Estienne," whom he owes 60

Source	Date	Notaries or signatories	Details
			ecus. There are several others whom I won't list, but the total owed is 373 livres, leaving a wedding gift or dowry of about 700 livres. The dower is to be customary or 200 livres, without return.
AN ET/LVX/161 <i>Inventaire après décès</i> Guillaume Le Bé le 14 Juillet 1598	1572 jeudy dixieme jour 6. de janvier mil Vc Lxxii And 1572 du xeme (10) jour davrill audit an ml Vc Lxxii	Franquelon et Croisot	ung contract du Chatellet de Paris en datte du jedy dixieme jour de janvier mil Vc Lxxii (1572), signé Franquelon et Croisot, contenant Messire Anthoine le Cirier evesque d'Avranches doie, de leglise de Paris, de Guillaume le Cirier son frere escuier gentilhomme servant ordinaire de Monseigneur le duc d'Allancon, avoir vendu, ceddé transporté et promis garantir audit defunct Guillaume Lebé une maison, petite cour et appartenances, en laquelle pend pour enseigne "la Grosse Escriptoire" assise a Paris en la rue St Jehan de Latran et ladite vente avoit esté faicte aux charges et moienant le pris et some de dix huit cens livres tz qui en auroit esté lors païée, ainsi en fin duquel est la saisine de ce prinse, signée Foullon et la ratification dicelle vente faicte par ledit Guillaume le Cirier, en datte du xeme (10) jour davrill audit an ml Vc Lxxii (1572) signé desdits Franquelon et Croiset, inventoriés sur ledit contract quatre
Renouard, <i>Documents sur les imprimeurs</i> etc p. 154 AN: S. 1653, fo. 64, 3ieme serie	Le 10 janvier 1572		Guillaume Le Be, papetier (et fondeur) bourgeois de Paris, achète pour 1,800 l.t. la maison de la grosse escriptoire, contiguë a une maison qui appartenant déjà rue Saint-Jean de Latran. Le vendeur est Guillaume Le Cirier, représenté par Antoine Le Cirier évêque d'Avranches.
Pichon and Vicaire 1895, <i>Documents pour servir à l'histoire des libraires à Paris</i> Archive de Cothureau, Notaire	2 Juillet 1574		Document mentions sire Guillaume Le Bé, marchand papetier demerurant en l'Universite de Paris in a matter of lodgings?
Renouard, <i>Documents sur les imprimeurs</i> etc p. 95 AN: Y5251, fo. 36, fo verso	12 juillet1575		Nomination d'un subrogé tuteur a Robert et Henri Estienne, enfants mineurs du feu Robert Estienne, maître-imprimeur, et de Denyse Brabé, remariée a Mamert Patisson, maître-imprimeur. Le conseil de famille est composé de Mamert Patisson, beau-père, Jean Lyébault, docteur régent de la faculté de médecine, cousin paternel par sa femme, Francois Estienne, oncle paternel, Frédéric Morel, (imprimeur) cousin paternel par sa femme, Tessermant Barbé (mercier), oncle maternel, maître Germain Binoys, avocat au Parlement, voisin, Philippe Patisson, affiné et ami et Guillaume Le Bé, fondeur de lettres.
P. Renouard, <i>Documents sur les imprimeurs...</i> 1901, p.155 (Arch. Nat., S 1654, f° 28, Ire série.)	22 septembre 1576.		Guillaume Le Bé, marchand papetier à Paris, et Loyse Lambert, sa femme, achètent deux corps d'hôtel contigus, rue Saint-Jean-de-Beauvais, à l'enseigne de la Pommede Pain (sic), entre l'Eschiquier, à Aymon Marcot, et une maison leur appartenant, au prix de 100 l. t. de capital et 160 l. 13 s., 4 den. t. de rente. Les vendeurs sont François Le Cirier, président des enquêtes au Parlement, et Léonne Jacquet, sa femme.
AN ET/LVX/161 <i>Inventaire après décès</i> Guillaume Le Bé le 14 Juillet 1598	1576 en datte du samedi xxieme (22) jour de septembre mil Vc soixante seze	Belot et Nynlon	Le premier signé Belot et Nynlon, en datte du samedi xxieme (22) jour de septembre mil Vc soixante seze (1576), par lesquelles apert: messire Francois le Cirier, conseiller du roy en son privé conseil et court de Parlement et president es requestes dicelluy et dame Jehanne Jucquet sa feme, avoir baillé et transporté a

Source	Date	Notaries or signatories	Details
			titre de vente et promis garantir ausdits deffunctz Guillaume Lebé et Loise Lambert, lors sa feme, deux corps entretenans et jognans lun laultre, assis a Paris rue St Jehan de Beauvais ou souloit pendre pour enseigne "la Pomme de Pin" et ledit bail avoir esté fait aux charges et moienant huitz vingtz (8x20 = 160) six livres treze solz quatre deniers tz de rente annuelle que lesdits Lebé et sa femme en auroient lors promis paier et continuer aux termes, selon et ainsi que le tout est plus au long contenu et décrit audit contract, en fin duquel est la saisine de ce prinse, signé Foullon.
Renouard, <i>Documents sur les imprimeurs</i> etc p. 155 AN: S. 1654, fo. 28, 1er serie	22 septembre 1576		Guillaume Le Be, marchand papier a Paris, et Loyse Lambert, sa femme, achètent deux corps d'hôtel contigus, rue Saint-Jean-de Beauvais a l'enseigne de la Pomme de Terre (sic) entre l'Eschiquier a Aymon Marot et une maison leur appartenant, au prix de 100 l.t. de capital et 160 l.t. 4 den. T. de rente. Les vendeurs sont François le Cirier, président des enquêtes au Parlement de Paris, et Léonne Jacquet, sa femme.
AN ET/LVX/161 <i>Inventaire après décès</i> Guillaume Le Bé le 14 Juillet 1598	1577 en datte du mardy second de juillet mil Vc soixante dix sep	Cayard et Boreau	La seconde signée Cayard et Boreau en datte du mardy second de juillet mil Vc soixante dix sept (1577), par laquelle apert ledit Sieur conseiller le Corier et sa femme avoir baillé et transporté par exchange aux chanoynes et chappelains de Saint Maur des Fossez lesdites huitz vingtz (160) six livres treze solz quatre deniers tz de rente pour les si ainsi quil est contenu esdites lettres
AN ET/LVX/161 <i>Inventaire après décès</i> Guillaume Le Bé le 14 Juillet 1598	1581 premier jour de janvier mil Vc iii xxi (1581)	Chappellan	Ung autre contract du Chatellet de Paris signé Chappellan, en datte du premier jour de janvier mil Vc iii xxi (1581) contenant les promesses de mariages faites et accordées entre lesdits Claude Andrenas et Madeleine Lebé sa femme, en faveur du quel et pour y parvenir ledit deffunct Guillaume Lebé son pere auroit promis leur donner, bailler et paier la somme de neuf cens escus sol en deniers comptant pour les causes et ainsi quil est conté audit contract, en fin duquel est le quictement de ladite somme de neuf cens escus sol, signé dudit Chappellan, datté du 21. xix eme (19) jour dudit mois de janvier audit an, inventorié sur ledit contrat deux
AN ET/LVX/161 <i>Inventaire après décès</i> Guillaume Le Bé le 14 Juillet 1598	1583 datte du mardy premier fevrier mil Vc iii xx trois	Dubois et Chappelain	La troisieme signée Dubois et Chappelain, en datte du mardy premier fevrier mil Vc iii xx trois (1583) contenant les chanoynes et chappelans de Saint Maur des Fossez avoir receu dudit deffunct Guillaume Lebé, tant en son nom que comme tuteur de ses enfans et de ladite feu Loise Lambert, la somme de xxxx six cens soixante six escus deux tiers pour le rachapt et admortissement desdites huitz vingt (160) six livres treze solz quatre deniers tz de rente. Ainsi inventoriés sur lesdites trois pieces cinq
AN ET/LVX/161 <i>Inventaire après décès</i> Guillaume Le Bé le 14 Juillet 1598	1585 datte du deux janvier mil Vc iii xx cinq (1585)	Perier	- Item, une ceddulle en papier signée Perier, en datte du deux janvier mil Vc iii xx cinq (1585), par laquelle apert: Come Perier deavoir audit deffunct Lebe la somme de trente ung escus et trente solz tz pour les causes et a paier au terme declaréz en ladite ceddulle. Inventoriée au dessoubz dicelle seize
AN ET/LVX/161	1586 en datte du	le Vasseur et le Rey	Et ledit contract signé le Vasseur et le Rey, en datte du septiesme jour de janvier mil Vc iii xx six (1586),

<i>Source</i>	<i>Date</i>	<i>Notaries or signatories</i>	<i>Details</i>
<i>Inventaire après décès</i> Guillaume Le Bé le 14 Juillet 1598	septiesme jour de janvier mil Vc iiiii xx six		par lequel ledit M° Lambert docteur en medecine, Anne Lambert et en leurs noms ledit deffunct Guillaume Lebe, audit nom et comme tuteur de ses enffans et de ladite feu Loise Lambert jadis sa femme et encores tous chacun eux faisant fors de M° Nicolas Lambert leur pere xxxxx chirurgien et varlet de chambre du roy et Mr Ysmael Lambert leur frere, auroient baillé et transporté a tiltre de rente audit Corier boullanger, une maison, lieux, appartenances, assise es faulx bourgts St Jacques en la grand rue et ce moienant aseze escus deux tiers de rente annuelle et perpetuelle que ledit Corier en avoyt promis paier et continuer aux termes, selon et ainsi que le tout est plus au long contenu et ... audit contract, inventorié sur les deux susdites lettres, si sus inventorisées, lesquelz contractz lesdits Lebé et Andrenas.(deux lignes trop pales, illisibles)
AN ET/LVX/161 <i>Inventaire après décès</i> Guillaume Le Bé le 14 Juillet 1598	1587 en datte du xix eme (19) jour de juillet mil Vc iiiii xx sept (1587),	Richet	Item une ceddulle (a bill or IOU) en papier, signée Richet, en datte du xix eme (19) jour de juillet mil Vc iiiii xx sept (1587), par laquelle le Sieur Jehan Richet marchand libraire et M° imprimeur a promis devoir audit deffunct Guillaume Lebe, la somme de soixante neuf escus vingt solz et neuf deniers tz pour les causes et a prendre au terme declarez en ladite ceddulle. Inventorié au bas dicelle unze
AN ET/LVX/161 <i>Inventaire après décès</i> Guillaume Le Bé le 14 Juillet 1598	1587 en datte du xxiiii eme (24) jour dudit mois de juillet mil Vc iiiii xx sept (1587)	Richet	Item, une autre ceddulle signée comme la precedente, en datte du xxiiii eme (24) jour dudit mois de juillet mil Vc iiiii xx sept (1587) contenant ledit Jehan Richet devoir audit deffunct Guillaume Lebe la somme de cent quatre vingtz sept livres dix solz tz pour les causes et a paier au terme declaré en ladite ceddulle. Inventoriée au dessoubz dicelle douze
AN ET/LVX/161 <i>Inventaire après décès</i> Guillaume Le Bé le 14 Juillet 1598	1588 datté du xxeme jour de may mil Vc 10. iiiii xx huit	Jacques le Noir	Deux contractz du Chatelet de Paris, lung datté du xxeme jour de may mil Vc iiiii xx huit (1588) signé Jacques le Noir, contenant ledit deffunct Guillaume Lebé. au nom et comme tuteur et curateur des enffans myneurs xxxxxxxxxxxxxxxx d'ans, de luy et de ladite feu Loise Lambert, Claude Andrenas et Madelaine Lebé sa femme et Jehan Canelat et Margueritte Lebé sa femme, avoir reçu de Ysmael Lambert chirurgien et varlet ordinaire du roy, la somme de vi xx (120) livres et xx solz sur et tant moins de la somme de iii c xxxiiii (333) escutz pour la quatrieme partie et portion appartenant aux enffans de ladite feu Loise Lambert, au pris de la vente faite audit Ysmael Lambert dune maison, court et jardin assise pres la ville Saint Denis en France et pour le surplus desdits iii c xxx iii (333) écus xx solz, ledit Ysmael Lambert auroit baillé, cédé et transporté audit deffunct Lebe et ses enfans seze escus deux tiers de reste que luy estoient \deubz/ par Cornet xxx boullanger demurant au faulx bourgs et Jacques Aneson.
AN ET/LVX/161 <i>Inventaire après décès</i> Guillaume Le Bé le 14 Juillet 1598	1588 en datte du xxvi eme (26) jour de septembre mil Vc iiiiii xx huit	Fardeau et Charles	Item, trois obligations du Chatelet de Paris. La premiere signée Fardeau et Charles, en datte du xxvi eme (26) jour de septembre mil Vc iiiii xx huit (1588). La seconde, signée Belot et Fardeau, en datte du neufviesme jour doctobre mil Vc iiiii xii (1592). Et la

Source	Date	Notaries or signatories	Details
	1592 en datte du neufviesme jour doctobre mil Vc iiiiix xii (1592). 1596 en datte du xiii eme (13) juillet mil Vc iiiiix seize (1596)	Belot et Fardeau Charles et Francois	troisieme signée Charles et Francois, en datte du xiii eme (13) juillet mil Vc iiiixx seize (1596) . Par lesquelles le sieur Denis Binet M° imprimeur a Paris devoit audit deffunct Guillaume Lebe la somme de soixante quinze escus dix neuf solz tz pour les causes et a paier au terme y declaréz. Inventoriéz sur lesdites trois obligations, lune comme lautre. vingt ung - En inventariant lesquelles trois obligations, lesdits Lebe et Andrenas ont declairé quil ne reste deub du contenu dicelles sinon que la somme de trente cinq escus quinze solz six deniers, ainsi quil apert sur le papier journal dudit deffunct.
AN ET/LVX/161 <i>Inventaire après décès</i> Guillaume Le Bé le 14 Juillet 1598	1589 en datte du sixiesme jour de juillet mil Vc iiiixx neuf (1589),	Estienne Prevosteau, Charles et Fardeau,	Item, ung brevet dudit Chatelet, signé Prevosteau, Charles et Fardeau, en datte du sixiesme jour de juillet mil Vc iiiixx neuf (1589), contenant Estienne Prevosteau imprimeur libraire a Paris, devoir audit deffunct de cinquante sept escus treze solz pour les causes et a paier au terme declairez audit brevet. Inventorié sur icelluy vingt Au dos duquel apert avoir esté sur ce receu trente sept escus treize solz tz, a plusieurs fois. Davantage, lesdits Lebe et Andreas ont déclaré que outre le contenu audit brevet, ledit Prevosteau doit encores audit deffunct Lebe leur pere, la somme de quinze escus sol, ainsi quil apert sur son papier journal .
AN ET/LVX/161 <i>Inventaire après décès</i> Guillaume Le Bé le 14 Juillet 1598	1590 datte du xiii eme (13) octobre mil Vc iiiiix dix (1590),	Lusson et Leynoir	Item, ung contract du Chatelet de Paris, en datte du xiii eme (13) octobre 3. mil Vc iiiixx dix (1590), signé Lusson et Leynoir, par lequel apert 4. Simon Calvarin marchand, bourgeois de Paris et Anthoinette 5. Leynoir sa femme, chacun pour le tout, devoir audit deffunct Guillaume Lebe, la somme de cent soixante dix huit escus quarante sept solz neuf deniers tz pour les causes et a paier au termes declairez audit brevet. Inventorié sur iceluy xxiiii (24) Avec lequel sont attachez plusieurs exploitz precedans, sentences, de biens et declarations de despans et autres pieces. En inventariant lequel contract, lesdits Le-be et Andrenas ont declairé quil nest plus deub de tout ce, sinon que la somme de cent trente huit escus dix sept solz neuf deniers.- Davantage, lesdits Lebe et Andrenas ont declairé que par le papier journal dudit deffunct, il apert estre deub ce que disent. - Scavoir par ledit Jacques Dupuis, cinq escus douze solz. . Par Pierre Fieffe marchand libraire, ung escu quarante cinq solz. . Par Pierre Lullier marchand libraire, cinq escus vingt sept solz. . Par ung Mr Lesleu marchand de biens, six escus quarante solz. . Par Pierre Bourgeois et parties, quatre escus . . Par le Sieur Leger Delas marchand imprimeur, vingt six escus trente ung . . Par Arnoul Titan et par parties, trente six escus dix solz. Par le Sieur Baptiste Dupins, quatre escus sol. Par le Sieur Michel Souyns et parties, seize escus cinquante ung solz. Par Arnoul Cottrier M° imprimeur, neuf escus vingt

Source	Date	Notaries or signatories	Details
			quatre solz. . Par le Sieur Philippes Dupin marchand libraire, la somme de onze escus deux solz six deniers.
AN ET/LVX/161 <i>Inventaire après décès</i> Guillaume Le Bé le 14 Juillet 1598	1591 en datte du cinquiesme .jour de septembre mil Vc iiiix xi (1591)	Adrian le Roy	Item, une ceddulle en papier, signée comme la preceddente, escripte au dos de quelques parties, en datte du cinquiesme .jour de septembre mil Vc iiiix xi (1591), par laquelle le soubzsigné confesse devoir audit deffunct Lebe la somme de vingt neuf escus quarante solz a paier au terme declarez en ladite ceddulle. Inventoriée au bas dicelle quatorze - Davantage, lesdits Lebe et Andrenas ont déclaré que sur le . pappier journal dudit deffunct leur pere, il apert que ledit Adrian le Roy doit encores, outre ce, la somme de dix escus . vingt cinq solz .
AN ET/LVX/161 <i>Inventaire après décès</i> Guillaume Le Bé le 14 Juillet 1598	1591 en datte du xxixeme (29) jour de juillet mil Vc iiiix xi (1591)	Jehan Corbon	Item une ceddulle en pappier, en datte du xxixeme (29) jour de juillet mil Vc iiiix xi (1591) signée Jehan Corbon, contenant le soubzsigné Jehan Corbon libraire a Paris, comme tuteur des enfans de feu Thomas Bremet, vivant aussi libraire, devoir audit deffunct Lebe la somme de soixante six livres pour les causes et a paier au terme declarez en ladite ceddulle. Inventoriée au bas dicelle quinze Au dos de laquelle apert avoir esté sur ce recu huit escus quarante huit solz
AN ET/LVX/161 <i>Inventaire après décès</i> Guillaume Le Bé le 14 Juillet 1598	1591 en datte du xxvieme (26) jour de juin mil Vc iiiix xi (1591)	Denis Duval	Item, ung brevet dudit Chatellet, en datte du xxvieme (26) jour de juin mil Vc iiiix xi (1591), signé Denis Duval et contenant Denis Duval marchand libraire a Paris debvo[r]ir audit deffunct Lebe la somme de quarante escus quarante solz tz pour les causes et a paier au terme contenuz audit brevet. Inventorié au bas dicelluy dix huit
AN ET/LVX/161 <i>Inventaire après décès</i> Guillaume Le Bé le 14 Juillet 1598	1591 en datte du vingtiesme jour de fevrier mil Vc iiiix xi (1591)	Mamert Patisson	Item, une sentence des juges et consulz de ceste ville de Paris, en datte du vingtiesme jour de fevrier mil Vc iiiix xi (1591), signée L....., contenant Mamert Patisson marchand libraire a Paris avoir esté condampné paier audit deffunct Lebe la somme de deux cens vingt ung escus six solz contenu en sa ceddulle du xxixeme (29) juin mil Vc iiiix cinq (1585) et vingt sept escus dix solz pour vente de fonte dimprimerie et avoir esté condampné es despens, taxéz a seze solz. Avec laquelle sentense estre la susdite ceddulle, inventoriée sur icelle et sur ladite sentence, lune comme lautre dix neuf
AN ET/LVX/161 <i>Inventaire après décès</i> Guillaume Le Bé le 14 Juillet 1598	1591 en datte du xxvii eme (27) jour daoust mil Vc iiiix xi (1591)	Genres	Item, la sentence donnée des juges et consulz de ceste ville de Paris, en datte du xxvii eme (27) jour daoust mil Vc iiiix xi (1591), signée Genres, contenant ledit Consolat avoir este condampné paier audit deffunct Lebe la somme de escus tz pour les causes et au terme declairéz, au bas de laquelle apert quavoit esté receu par ledit deffunct la somme de huit escus sol . Inventorié vingt trois. Lesdits Lebe et Andrenas ont dit que outre ladite somme, ledit Leon Camelat doit encores audit deffunct trois escus sept solz, ainsi quil est escript sur le pappier journal dudit deffunct. (bas de page très pale et flou, mais barré)
AN ET/LVX/161 <i>Inventaire après décès</i> Guillaume Le Bé le 14	1595 en datte du xv eme (15) jour de mars mil Vc iiiix xv	Felesac et de Saint Vaast	Item, ung brevet dudit Chatelet, signé Felesac et de Saint Vaast, en datte du xv eme (15) jour de mars mil Vc iiiix xv (1595) contenant Guillaume Anuray marchand libraire a Paris et Gaspard Cure marchand de

Source	Date	Notaries or signatories	Details
Juillet 1598	(1595		vins, demeurant Rue St Martin, chacun pour le tout, devoir audit defunct Guillaume Lebe, la somme de quatre vingtz escus sol, pour les causes et a paier au terme declairéz audit brevet, au dos duquel apert avoir esté sur ce receu a plusieurs fois, jusques a soixante escus sol. Inventorié audit . dos vingt deux
AN ET/LVX/161 <i>Inventaire après décès</i> Guillaume Le Bé le 14 Juillet 1598	1596 en datte 14. su xixeme (19) jour davrill mil Vc iiixx xvi (1596),	Adrian le Roy	Item, une ceddulle en papier, signée Adrian le Roy, en datte 14. su xixeme (19) jour davrill mil Vc iiixx xvi (1596), contenant le soubzsigné devoir audit feu Guillaume Lebe la somme de soixante deux escuz trente trois solz tz pour les causes conttenues en ladite ceddulle. Inventoriée au dessoubz dicelle treize
AN ET/LVX/161 <i>Inventaire après décès</i> Guillaume Le Bé le 14 Juillet 15988	1598 en datte du xxvii eme (27) jour de mars mil Vc iiiixx xviii (1598),	René Nyvelle et R. Nyvelle,	Item, une ceddulle en papier, signée René Nyvelle et R. Nyvelle, en datte du xxvii eme (27) jour de mars mil Vc iiiixx xviii (1598), par laquelle apert les soubzsignéz devoir audit feu Lebe, la somme de trente cinq escus pour les causes (suit in, law?) et a paier au terme declaréz en ladite ceddulle. Inventoriée sur icelle dix sept
AN ET/LVX/161 <i>Inventaire après décès</i> Guillaume Le Bé le 14 Juillet 1598	1598 datté du xxiii eme (23) jour de juillet mil Vc iiiixx xviii (1598),	Lois Rion	Item, deux feuilles de papier attachés ensemble, dont les deux premiers fueilletz sont escriptz entierement et quelque sur le troisieme, signé Lois Rion, datté du xxiii eme (23) jour de juillet mil Vc iiiixx xviii (1598), contenant la description et prisée faicte par ledit Rion de toute la marchandise de pappier qui sest trouvée apres le decez dudit defunct. Inventoriez au dessoubz du seing vingt six
AN ET/LVX/161 <i>Inventaire après décès</i> Guillaume Le Bé le 14 Juillet 1598	1598 datté du vingtiesme juillet audit an mil Vc iiiixx xviii (1598),	Jacques Duclos et Jacques de Sanlecque	Item, ung cahier de papier contenant quatre feuilles de papier attachées ensemble. Dont les six premiers fueilletz sont escriptz entierement et presque la moictié du septiesme, datté du vingtiesme juillet audit an mil Vc iiiixx xviii (1598), signé Jacques Duclos et Jacques de Sanlecque, contenant la description et prisée par eulx faicte des matrices, moules, poinçons et autres ustancilles servans a la fonte de lettres dimprimeries, trouvés apres le decez dudit defunct. Inventoriéz audessous des seings vingt sept conté lesquelles descriptions lesditz Lebe et Andrenas nont voulu estre escriptes par et se sont absentéz..... Inventoriés toutes lesquelles matrices, marchandises, papiers et . livres, lesdits Lebe et Andrenas nont voulu estre mis . par au present inventaire et se sont contentéz que desdites descriptions et prisées soient ainsi inventoriéez/. Lesquelles ont esté paraffées par ledit le Noir notaire, en la fin des susdites pages. Lesdits Lebé et Andrenas a cause des sucessions de feuz M° Nicolas Lambert et Margueritte (illisible)
AN ET/LVX/161 <i>Inventaire après décès</i> Guillaume Le Bé le 14 Juillet 1598			La quatriesme partie et portion dune maison assise a rue Ma..... parolles. Item une maison assise es faulboulx Notre Dame des Champs, ou souloit pendre pour enseigne "les VerdzGallandz". Item une arpen de prey xxx prins en une piece contenant quatre arpens. Item la moictié dun pré contenant ung arpen, nommé le pré Saint Martin. Item, ung arpen dix neuf perches de terre .

Source	Date	Notaries or signatories	Details
			Et trois arpens unze perches, en une piece. Le tout assis près leglise Saint Remy les Saint Denis en France . Item, ung arpen de terre que souloit estre en vigne, assis au terroir de Pierefonds. Signatures
AN ET/LVX/161 <i>Inventaire après décès</i> Guillaume Le Bé le 14 Juillet 1598	1598 en datte du sixiesme jour de aoust mil Vc iiiixx xviii (1598)	Jehan Carbon	Item, ung cahier de papier contenant huict fueilletz escriptz, escriptz fort prez et quelque peu sur le neuvieme, signé sur iceluy Jehan Carbon, en datte du sixiesme jour de aoust mil Vc iiiixx xviii (1598) contenant linventaire par luy mené, description (trop pale, illisible) . et estimation faicte par ledit Jehan Carbon de tous les livres trouvéz apres le decez dudit deffunct, inventoriés sur ledit neufviesme fueillet, audessoulz dudit seing vingt cinq
Archives nationales, ET.XLV/161	14 Juillet 1598	Inventaire après deces Le Bé	
		Les Le Bé sont sans doute plus riches que Robert Estienne, au moins en propriétés.	Sur les niveaux de fortune, voir: P. Renouard, Documents sur les imprimeurs... 1901, p. 154-155, achats de plusieurs maisons par les Le Bé: montant à comparer avec les legs et sommes variées que je cite dans mon article sur Garamont (Mélanges Henri-Jean Martin).
James Mosley list 2011		c. 1599	7. The Le Bé–Moretus collection of fragments c. 1599 Guillaume II Le Bé sent these annotated examples of printing in some of the types for which the foundry had materials to Jean Moretus, son-in-law of Christophe Plantin (d. 1589). The notes give the names of the punchcutters. They were reproduced in Type specimen facsimiles II: reproductions of Christopher Plantin's Index sive specimen charac-terum, 1567, and Folio specimen of c. 1585, together with the Le Bé–Moretus specimen c. 1599; with annotations by H. D. L. Vervliet and Harry Carter (London, 1972). Location of originals: Museum Plantin–Moretus, Antwerp. Inserted in a volume (No. 153) of the archives. And photocopy in BnF
	1600	Guillaume II typesetter and paper merchant opened a shop in the rue Jean de Beauvais and joined the Confrerie de St. Jean l'Évangéliste	B.N. M.F. 11, 692 21, 872
Renouard, <i>Documents sur les imprimeurs</i> etc p. 154 Bib. Nat. ms. Fr. 11692, fo. 758 verso et 759 verso, ms. Fr. 21872	18 septembre 1600		Guillaume Le Be (sic) (imprimeur et fondeur de lettres) paye la taxe d'ouverture de boutique.
B.N. M.F. 11, 692 21, 872 From SM's notes in CU Library	1600	Guillaume II typesetter and paper merchant opened a shop in the rue Jean de Beauvais and joined the Confrerie de St. Jean l'Évangéliste	
B.N. MF 22, 117 From SM's notes in CU	1614	Three letters by G. II to typesetters in Lyons	Lettres écrites par les fondeurs de ceste cille de Paris pour la conservation du monopole fait entre eux, au

<i>Source</i>	<i>Date</i>	<i>Notaries or signatories</i>	<i>Details</i>
Library Mentioned in BnF 22117 (Inventaire de la collection Anisson)		and Geneva asking them not to sell good type to Jacques Aumont	prejudice des marchands libraires et imprimeurs de ceste ville; Première lettre: « Au sire Pierre Mourier, maistre fondeur de lettres, demeurant a Genève, signée Le Be (sic) Paris 16 Novembre 1614; Deuxième: Au Sire Denis de Lorme, maistre fondeur de lettres pour l'imprimerie, demeurant rue Paradis, a Lion, signée Jacques de Sanlecque, Guillaume Le Bé et Jean Mejat (meme date); Troisième: Au Sire Sébastien Bouillant, a Lyon, signée Le Bé (meme date)
James Mosley list of documents February 2011	c.1617	??	1. Le Bé Inventory c.1617 Compiled by Guillaume II Le Bé about 1617. There is a reference by Jean-Pierre Fournier (l'aîné) to an inventory of the Le Bé foundry in his possession, compiled by Guillaume II Le Bé, that, if it ran to 32 or more pages and in-cluded the text transcribed below, was clearly far more extensive than the document of 1730, of which it was presumably an edited summary. Fournier l'ainé wrote (Mercure de France, mai 1756, p. 123-4), 'Guillaume le Bé vendit à Plantin des frappes de ses caracteres Hébreux, mais il en garda les poinçons; ce qui se justi-fie premièrement par l'inventaire de la fonderie de G. Le Bé, dressé par son fils, dans lequel inventaire on lit ces mots page 32, & en la même boîte (ou est l'Hébreu canon) est l'Hébreu Parangon: il est gros comme celui de la Bible in-4o de Robert Estienne: & celui-ci est celui de la grande Bible de Plantin, mon Pere lui en ayant vendu une frappe. La Bible de M. le Jay en est imprimée. Cette frappe ci est garnie de points et accens.... Les poinçons sont cé- ans. On voit par cet inventaire dont je suis possesseur, que les poinçons des caracteres Hé-breux qui servirent à imprimer la belle Bible de Plantin, ne furent point vendus à Plantin, mais qu'ils passerent au fils de Guillaume Le Bé, aussi bien que tout le fonds de Garamond.' Location of original: unknown.
James Mosley list of documents February 2011		c. 1617 transcribed and edited 1730	2. Le Bé Inventory c.1617, transcribed and edited 1730 A summary transcription of 8 pages made from the inventory originally compiled by Guillaume II Le Bé in about 1617 (See above) for insertion in the sale document of the Le Bé foundry to Jean-Pierre Fournier, signed and dated 23 December 1730. This inventory was published as: L'inventaire de la fonderie Le Bé, selon la transcription de Jean Pierre Fournier. Paris: Imprimé à petit nombre pour André Jammes, 1957. 30 pp. Foreword, 'The inventory of the Le Bé foundry', pp. 7-17, by Stanley Morison. (Documents typographiques français, I.) In the printed text of 1957, there are no reproductions of the original document, except for one paragraph with signatures appended which is reproduced in line on p. 28. The wording of the paragraph is not transcribed. Morison wrote in his foreword (p. 11), that 'the Deed of Sale was signed before the notary Laideguive, on 20 December 1730, by Angélique and Marie Le Bé, and Mme Veuve Fournier, née Guion, who signed as guarantor in behalf of her son. Annexed to the Deed of Sale is a priced inventory of the punches, matrices,

Source	Date	Notaries or signatories	Details
			<p>moulds, etc. which comprised the property. This is the document which it is now our business to introduce to the reader.'</p> <p>The signatures reproduced on p. 28, which also appear elsewhere in the document, appear to be: Angelique Le Bé, M M (for Marie Marthe) Le Bé, Anne Catherine Diou veuve Fournier, Jean Pierre Fournier, and the two lawyers' signatures, one of which is illegible and the other is the name given by Morison (presumably following Abbot) as 'Laideguive'. The family name of Anne Catherine, veuve Fournier, was given by Morison in his introduction of 1957 as 'Guion'. Olive Abbot, who was searching in Paris for materials on Morison's behalf, gave it as 'Dion' in a letter to Morison dated 25 March 1950, Morison Papers, ULC. Jammes also queried Morison's spelling in a letter. The written date appears to be 'Ce vingt trois Decembre mil sept cent trente'.</p> <p>Morison's introduction states that the inventory 'consists of seven leaves [in fact it comprises eight pages] of 18th century current script which purport to list the contents of the foundry as they existed at the time of the transfer from the Le Bé sisters to Jean Pierre Fournier', and that 'there can be no doubt ... that the particulars [of] the Le Bé – Fournier inventory of 1730 are based upon an original inventory drawn up by Le Bé II'.</p> <p>The complete document has sixteen pages, consisting of an eight-page legal contract relating to the sale of the foundry written on two folded sheets of stamped paper with a leaf size of 33 × 22 cm, and, inserted in the centre of the contract, the eight-page inventory, written on four leaves, comprising two folded sheets of a larger unstamped paper, sheet size 40 × 50 cm, which gives a leaf size of 40 × 25 cm. Each leaf has been folded at the sides and bottom in order to align with those of the contract and the other documents in the liasse or bundle.</p> <p>An unsigned note in French on p. 29, added by the publisher (André Jammes), begins thus: 'Dans cette transcription, l'orthographe fantaisiste a été scrupuleusement respectée. Certainement Saint Augustin romain « pour Cuime » veut dire « povre cuivre ». ... Nous avons attaché beaucoup d'importance au dessin des signes qui servaient à marquer les boîtes des matrices ou de poinçons ...'</p> <p>The signs are carefully and professionally redrawn and reproduced in line. The printed text does not reproduce the capitalisation and punctuation or even the wording of the original document with complete fidelity.</p> <p><i>Photographic copies of original:</i> Photographs were made by JM of the whole document in August 2010. The current location of the photographic copy used for the printed transcription of 1957 is not known.</p> <p><i>Location of original:</i> Minutier central des Notaires, Étude lxxv, liasse 229. The unsigned note on p. 29 of the printed edition, which has been quoted in all later studies, gives this erroneous côte: Minutier central des Notaires, Étude lxxv, liasse 324. (This liasse or 'bundle'</p>

Source	Date	Notaries or signatories	Details
			contains no related document.)
Archives nationales V ⁶ 96. From Paul-Marie Grinevald	30 mai 1634		Arrêt du Conseil d'État privé ordonnant à Guillaume LE BÉ, fondateur de lettres, de déposer les matrices des « Grecs du Roi » entre les mains de François de THOU, conseiller de Sa Majesté & grand maître de sa Bibliothèque.
James Mosley list of documents February 2011		1643?	<p>4. <i>Le Bé Memorandum</i> Published as: Sixteenth century French typefounders: the Le Bé memorandum. Edited by Harry Carter, with a foreword by Stanley Morison. Paris: Privately printed for André Jammes, 1967. (Documents typographiques français, III.)</p> <p>On pages 6 and 7 of Carter's Introduction there is the following description of the document, apparently based on the photographs made for Morison (See below):</p> <p>"Four different handwritings occur in the 13 pages written on 7 sheets of paper (335 × 220 mm Half sheets of Teillere), except the last two, which are half as long. the penultimate leaf is written on one side only. (I have not been able to see the original. The paper used for the continuation might help to date it.) One is the semi-Gothic Ronde used for the 7½ pages of the Memorandum proper. On these pages is the text composed professedly (and quite probably) in 1643 by someone who refers to Guillaume Le Bé as his father. The hand is the copying hand of Guillaume II Le Bé or, perhaps more likely, of an amuensis to whom he dictated. A second hand, a sixteenth-century Gothic cursive, is responsible only for a marginal note on page 8 about the excellent moulds made by Jean Le Sueur. It is found also on some specimens of type at the Museum Plantin–Moretus in explanatory notes referring to Guillaume I Le Bé as 'feu mon pere' and assignable to correspondence between Guillaume II Le Bé initiated in 1598. This is the ordinary business hand of Guillaume II Le Bé. A third hand contributes the continuation of the Memorandum from the point where the first leaves off half-way down page 8. It also added interlinear and marginal glosses on pages 5, 6, and 7. This same hand transcribed the Inventory of the typefoundry and added the signature of Jean-Pierre Fournier to the notary's act ceding the property in it to him. This undistinguished example of the Italienne bâtarde as it was practised early in the eighteenth century must, therefore, be attributed to Fournier l'Ainé in his prime. A fourth hand, more crabbed, occurs in marginal comments on pages 7 and 8. It resembles one found in marginal notes on specimens of types offered by Fournier l'Ainé which were among the papers of Jean Anisson. This I take to be the writing of Fournier l'Ainé in later life. He died in 1783."</p> <p>The quality of Carter's transcription as printed in 1967 is very high.</p> <p>In his foreword to the Inventaire (1957) Morison wrote, 'I am further indebted to M. de Vaux for permitting me to examine and to photograph for purposes of publication, the Le Bé II memorandum.'</p> <p><i>Photographic copies of original:</i> The set of</p>

Source	Date	Notaries or signatories	Details
			photographs that Morison used and from which (or copies of them) Carter made his transcription were returned to André Jammes in Paris. Jammes passed them to JM in December 2010. <i>Location of original:</i> Uncertain. In 1957 the document was in the possession of Jacques Guérin de Vaux. Perhaps it still belongs to descendants of the Fournier family.
Dic. His.	1650	Guillaume II, died in Paris about that date.	
B.N. M.F. 21, 819 From SMs notes in CU Library	1680	Guillaume III (presumed son of above) was given charge of punches and matrices in place of Robert Estienne	
Dic. His.	1685	Guillaume III died leaving only daughters	
James Mosley list of documents February 2011	16 September 1685		3. Le Bé Inventory 1685 Dated 16 September 1685. Included with the inventory of the property at his death of Guillaume III Le Bé. Of this document, which came to light after the publication of the Inven-taire in 1957, Carter wrote (Le Bé Memorandum, introduction, p. 13), 'The inventory of 1685, interesting as the last description of the collection made by Guillaume II Le Bé of the work of the most famous artists in letter-cutting, discloses few changes in the stock of the foundry since the second Guillaume made his inventory some sixty years before.' JM has copies of manuscript and typescript transcripts of the inventory made by Harry Carter, and also a comparison made by Carter of the contents listed in the two inventories. <i>Photographic copies of original:</i> Photographs were made by JM in August 2010. The original set of copies used by Carter and others has not been located. <i>Location of original:</i> Archives nationales, Paris, Minutier central des Notaires, Étude lxx, liasse 182.
	1707	Guillaume III's widow died and Jean Claude Fournier managed the foundry on behalf of the daughters	
LXV 229	1730		Le Bé Inventory
	1730	Jean Pierre Fournier, eldest son of above bought the Le Bé foundry from the daughters	??
Inventaire après deces of Pierre-Simon Fournier AN ET/LXIV/400	14 Octobre 1768	Inventory of Jean-Pierre Fournier's foundry	This inventory was made at the request of his son (?) Jean-Pierre Fournier - also listed as a <i>graveur et fondeur de caractères d'imprimerie</i> . The total inventory comprises 50 pages, in the usual format and style. At end are 11 pages comprising the inventory of the Foundry, estimated by Jean de Sanlecque and Vincent Denis Cappon. The names and estimations are given, and there is a set of Hebrew punches - no size given however.

<i>Source</i>	<i>Date</i>	<i>Notaries or signatories</i>	<i>Details</i>
James Mosley list of documents February 2011	1888	Omout article on MS. Nouv. acq. fr. 4528.	5. Le Bé type specimens 1545–72 H. Omout, Spécimens de caractères hébreux, grecs, latins et de musique gravés à Venise et à Paris par Guillaume Le Bé (1545-1572) (Paris, 1889), reprinted from Mémoires de la Société de l'Histoire de Paris et de l'Île de France, vol. 15 (1888), pp. 273-83. Photographic copies of original: see above. <i>Location of original:</i> Bibliothèque nationale de France, MS. Nouv. acq. fr. 4528.
James Mosley list of documents February 2011	1887	Omout article on Rés. X. 1665.	6. Le Bé type specimens 1546–74 H. Omout, Spécimens de caractères hébreux gravés à Venise et à Paris par Guillaume Le Bé (1546-1574) (Paris, 1888), reprinted from Mémoires de la Société de l'Histoire de Paris et de l'Île de France, vol. 14 (1887), pp. 257-64. <i>Photographic copies of original:</i> There are some photostat copies made from this and the next item for Stanley Morison among documents given to the St Bride Library by A. F. Johnson and Ellic Howe. <i>Location of original:</i> Bibliothèque nationale de France, Rés. X. 1665.

Le Bé Chronological List

(Typewritten notes by Miss O. A. Abbott, Stanley Morison's researcher in Paris for over 20 years. Cambridge University Library, Morison Papers XXVI.3)⁸⁸⁷

<i>Date</i>	<i>Event</i>	<i>Source</i>
1525	Guillaume I born at Troyes (Champagne) son of a paper merchant known as Guillaume l'ainé	Dic. His. Lalane
1539/40	Guillaume I apprenticed to Robert Estienne	De Vaux MSS.
1541	First date on Guillaume I's Livret Typo.	De Vaux MSS.
1542	Started to cut Hebrew type	De Vaux MSS.
1545	Apprenticeship ended. Left for Venice and started to work for himself	De Vaux MSS.
1549	Guillaume I - ninth Hebrew for Garamond?	??
1550	Guillaume I was present at the Jubilee in Rome and returned to Paris via Geneva after visiting his old master	De Vaux MSS.
1551	On his return from Italy Guillaume I. lived for a year chez Garamond, Maison de la Boule, rue des Carmes. Then he took up bookselling and the paper trade.	De Vaux MSS.
1552	Guillaume I established as independent craftsman and founder	??
1552	His father Guillaume l'ainé bought two adjoining houses in the rue St Jean de Beauvais	A. Nat. S-1652
1554	Music types cut for Robert Ballard and Adrien Le Buy (?) (Musique grosse, grosse tablature and petite tablature)	??
1559	Cut double canon Hebrew for Plantin	??
1561	Le Bé, Jean le Sueur drew up the inventory of Garamond's foundry, of which André Wechel was the executor. Plantin bought the matrices and moulds;	

⁸⁸⁷ Dic. His. = Marie Ludovic Chrétien Lalanne, *Dictionnaire historique de la France, etc* (Paris: Hachette, 1877) and De Vaux MSS = The original manuscript of the Le Bé Memorandum, owned by M. Jacques Guérin de Vaux, a descendant of the Fournier family.

<i>Date</i>	<i>Event</i>	<i>Source</i>
	Wechel bought the punches; Le Bé had a strike from some punches unspecified, before he sold them to Wechel. Also he had other punches from the widow Garamond.	
1565	Le Bé cut a very small Hebrew for Plantin	
1570	Guillaume II born. ninth child/Son of G. I. (Henri Guillaume in Dic)	Dic. His.
1592	Last date in Guillaume I's livret Typographique	X-1665
1598	Guillaume I died in Paris	Dic. His.
1600	Guillaume II typefounder and paper merchant opened a shop in the rue Jean de Beauvais and joined the Confrerie de St. Jean l'Evangeliste	B.N. M.F. 11, 692 21, 872
1614	Three letters by G. II to typefounders in Lyon and Geneva asking them not to sell good type to Jacques Aumont	B.N. MF 22, 117
1643	Guillaume II wrote his MSS re printers	De Vaux MSS
1650	Guillaume II, about that date, died in Paris	Dic. His.
1680	Guillaume III (presumed son of above) was given charge of punches and matrices in place of Robert Estienne	B.N. M.F. 21, 819
1685	Guillaume III died leaving only daughters	Dic. His.
1707	Guillaume III's widow died and Jean Claude Fournier managed the foundry on behalf of the daughters	??
1730	Jean Pierre Fournier, eldest son of above bought the Le Bé foundry from the daughters	??

Appendix F: Transcription of the *Inventaire après décès* of Guillaume I Le Bé of 1598

(Archives nationales de France, Côte: ET/LVX/161)

The transcription of this document was undertaken by PaléoFGW (<http://www.francegenweb.org/>) and in particular by Mme. M-Françoise who was able to decipher and transcribe a particularly difficult text. The Transcription was produced and authorised by FranceGenWeb.org⁸⁸⁸ The line numbers relate to the original documents as transcribed including crossed out or deleted lines. The original orthography has been retained with some explanatory notes added. The footnotes with explanatory notes for old French terms were added by the transcriber.

⁸⁸⁸ The original of this document is available at 'Inventory After Death (ET/XLV/161)' (<<http://www.geneanet.org/archives/actes/view/?idacte=131663&p=1>> [Accessed 6 November 2013]

Page 1

1. Lan mil cinq cens quatre vingtz dix huict, le mardy avant midy,
2. premier jour de juillet et autres jours ensuivans, a la
3. requete dhonorables personnes Guillaume Lebé \marchant bourgeois/ en son nom,
4. Claude Andrenas, marchans, bourgeois de Paris
5. a cause de Madeleine Lebé sa femme et de Marie le Bé
6. fille usante et joyssante de ses droictz. Lesdits Guillaume, Madele[ine]
7. et Marie Lebé frere et soeurs, enfans et habiles a eulx dire,
8. porter et nommer heritiers de defunctz honorables personnes
9. Guillaume Lebé marchand et bourgeois de Paris et de Loyse
10. Lambert, jadis sa femme, par nous Jehan Lusson et Nico[las]
11. Le Noir notaires du roy notre Sire en son Chatelet de Paris,
12. fait inventaire et description de tous et chacuns les
13. meubles, ustanciles dhostel, marchandise, vaisselle,
14. debtes et creances,, tiltres, papiers et enseignement
15. demeurez du decez et trespas dudit defunct Guillaume Lebé leur
16. pere. Lequel seroit decedé depuis ung mois en ca, ayant
17. survescu ladite defuncte Loise Lambert par longue espace
18. de temps, sans avoir fait aucun inventere. Iceulx biens
19. trouvez et estant en la maison en laquelle \iceulx desfunctz/ demouroient
20. et ou ilz seroient decedez, assise au cloz Bruneau,
21. monstréz, enseignéz et mis en evidence par lesdites partyes
22. et par Guillemette Chauvet servante dudit defunct qui a xxx
23. tousjours demuré en ladite maison, apres serment par eulx
24. et chacun deulx fait. Et est iceulx notaires, diceulx biens
25. monstrez et enseigner sans aucuns en cacherne latitter
26. sur les peynes de lordonnance que leur ont esté dictes
27. et exprimés, \iceulx biens/ priséz et estiméz. Scavoir les meubles et
28. ustanciles dhostel, par Jacques Moze sergent priseur,
29. vendeur de biens meubles au Chatelet, prevosté et universitez

Page 2

1. de Paris. La marchandise xxx de matrices, moules (+)
2. Marchant papetier a Paris, aussi apres serment et eulx
3. et chacun deulx fait, de tous et chacun iceulx biens priser et
4. estimer en leur conscience, sans faveur aucune a leur esgard, au cours

5. quilz ont de present. Ce faict, les ont priséz et estiméz aux sommes

6. de deniers et en la forme et maniere que ensuit.

7. Signatures

Guillaume Le Bé (II)

Andrenas Claude

Marie Le Be

Lemoine?

Cisbourg?

8. (+) p???.... et avec ustancilles

9. servant a lart de fondeur de

10. lettres d'imprimerie, par Jacques Delos et Jacques

11. Senlogne Maitres fondeurs de lettres

12. a Paris. Et la marchandise de

13. la Librairie.... xxxxxxxxxxxxxxxx par

14. xxxxx Jehan Corbon marchand libraire.

15. La marchandise de papier par Lois Rica.

16. xxxxxxxxxxxxxxxxxxxx

17.

18. Premierement a esté trouvé en la cave dudit hostel

19. huict cens ----- de thuille de grand moule⁸⁸⁹

20. vieille, prisé le millier six escuz, cy iiiii (4) escuz 8 solz tournoiz

21. Item, une xxx voie ⁸⁹⁰ de buches de de bois de chesne

22. prisés ii (2) escuz xx(20) solz tz

23. Item, ung chantier ⁸⁹¹ et \ trois/ boutz de chantier de bois de

24. chesne vieulx, avecq deux demy muidz (*en marge*: et ung petit bary a verguz) a gueule baye ⁸⁹² priséz

25. ensemble xxx (30) solz tz

26. Item, ung cent de fagotz ou environ, avecq quelque peu de souches

27. de bois de chesne, prisé ensemble i (1) escu xxx solz tz

28. Item, a esté trouvé en une cuisine de appartenance dudit hostel,

⁸⁸⁹ de 13 pouces de long dont un millier couvre 7 arpents de toit, alors que celles de petit moule ont 9 à 10 pouces de long

⁸⁹⁰ 2 stères = 1 cubic metre

⁸⁹¹ support de tonneau

⁸⁹² qui n'a qu'un fond, utilisé debout

29. quarante ais ⁸⁹³ de bois de chesne, hestre et autre bois de plusieurs
30. grandeurs, prisés ensemble cinq escuz, cy v escus
31. Item, une huche de bois blanc servant a pestrir xxxxxxxxxxxx,
32. ung sousflet, ung boisseau servant a mesurer grains, \deux/ petits
33. barylz, quatre bouteilles de verre couvertes dozier, une
34. lanterne garnie de corne, une petite eschelle de bois,

Page 3

1. deux paniers dozier, deux sallieres de bois et ung picotin ⁸⁹⁴ dozier,
2. prisé le tout ensemble xL (40) solz tz
3. Item, une petite paire de chesnetz de fer, garnye chacune de leurs pommes de cuivre
4. et de leur feu ⁸⁹⁵ deux chevrettes, ⁸⁹⁶ une cremaillere, deux petits contre rotiers
5. et ung petit treprier ... le tout de fer, prisé le tout ensemble i ecu xx(20) solz tz
6. Item, en une boutique joignant ladite cuisine, a esté trouvé deux petites xxxxx
7. homoires servants a mectre livres, de bois de haistre,
8. prisées ensemble xL(40) solz tz
9. Item, quatorze grandz ais servans a mectre livres, de bois de haistre et
10. autre bois, priséz ensemble ii (2 écus)
11. Item, une eschelle de bois blanc, deux petitz baris, deux hottes, une
12. petite tinette, \quatre /panniers, ung picotin. Le tout dozier. Ung rouet,
13. ung devidouer, une paire de tournettes ⁸⁹⁷ et ung petit esgoutoir dozier .
14. Prisé le tout ensemble, trente solz xxx (30) solz tz
15. Item en la sallette dudit hostel a esté trouvé ung grand banc a hault
16. dossier et a coffre xxx fermant a clef, garny de son marche pied,
17. prisé i écu xL (40) solz tz
18. Item une paire de chesnetz de fer a ruelle et contre rottiers garnis
19. de leur pommes de cuivre, une cramailiere et ung accoste-pot. ⁸⁹⁸ Le
20. tout de fer prisé ensemble i écu xx (20) solz tz
21. Item, ung tappis de cheminée, contenant deux aulnes ou environ a menuie
22. verdure, bestes et oyseaux, prisé avecq ung orellier
23. de tapisserie xLv (45) solz tz

⁸⁹³ planche

⁸⁹⁴ panier

⁸⁹⁵ ensemble de pince, pelle, etc

⁸⁹⁶ trépied à braise

⁸⁹⁷ bobines

⁸⁹⁸ demi-cylindre pour repousser les braises et maintenir un pot dans l'atre

24. Item, une paire dhomaires de bois de chesne, fermant a quatre
25. guychetz et a clef, prisé ii écus xL (40) solz tz
26. Item, ung buffet de bois de chesne fermant a ung guychet et a
27. clef, garny de sa layette ⁸⁹⁹ coulisse, xxx tel quel,
28. prisé xL (40) solz tz
29. Item deux chaises caquetoires, ⁹⁰⁰ deux placets ⁹⁰¹ et une autre chaise
30. basse garnie de tapisserie facon de drap dor, prisés
31. ensemble xxxv (35) solz tz

Page 4

1. Item une table de bois de chesne ploiante, assise sur son treteau, une
2. forme longue servant a sasseoir a table, trois chaises et trois
3. scabeaulz de bois de noier et chesne, prisé le tout ensemble iii (3) escuz sol
4. Item une autre petite paire homoires de bois de noier, a quatre guichetz
5. fermans a clef, prisee ii (2)écuz
6. Item ung tableau peinct sur toille, sans bordeure, ⁹⁰² ou est depeincte la Nativité
7. de Notre Seigneur, ung damier garny de ses dames, prisé ensemble L (50) solz tz
8. En la cuisine dudit hostel joignant ladite sallette, a esté trouvé une
9. paire dhomaires de bois de chesne a quatre estages et a deux
10. guychetz, servans a mectre vaisselle, priséz i écu
11. Item ung verrier de bois de chesne fermant a deux guichetz, a jour, ⁹⁰³
12. une selle ⁹⁰⁴ basse, ung petit placet, \ung ais/ et trois boutz d'ais
13. de bois de chesne, ung petit rondeau, ⁹⁰⁵ une jatte de
14. bois, ung autre verrier et une cage servant de garde
15. manger, prisé le tout ensemble xxx (30) solz tz
16. Item une fontaine de cuivre jaune tenant trois sceaulz ou environ, garnie
17. de son couvercle et robinet, prisee i écu xL (40) solz tz
18. Item, deux coquemars ⁹⁰⁶ de franc cuivre, tenant lung une carte ⁹⁰⁷ et
19. lautre trois demy septiers, ⁹⁰⁸ priséz ensemble ung écu i écu

⁸⁹⁹ petit tiroir pour cacher des papiers

⁹⁰⁰ chaise basse à haut dossier = causeuses

⁹⁰¹ tabourets

⁹⁰² cadre

⁹⁰³ ajouré

⁹⁰⁴ banc

⁹⁰⁵ rond-d'eau = baquet

⁹⁰⁶ récipient pour chauffer l'eau

⁹⁰⁷ ± 15 litres

⁹⁰⁸ 1demi sétier = 0, 25 litre

20. Item, \huict/ chodrons de plusieurs grandeurs, garnis de leurs
21. cercles et anses de fer, priséz ensemble i écu
22. Item, douze chandeliers de cuivre tant grandz que petitz, priséz
23. ensemble i écu
24. Item une bassinore, une couloire,⁹⁰⁹ ung poislon, ung
25. petit chodron sans ance, (*en marge*: une petite poisle) et quatre reschaulx, le tout
26. de cuivre, prisé ensemble ung escu dix solz i écu x solz
27. Item, sept potz de fer de plusieurs grandeurs, garnys de leur couvercle,
28. priséz ensemble xLv (45) solz tz
29. Item, quatre poesles et ung poislon, \six/ cuilliers, \quatre/
30. broches, deux gryot?, deux leschesfrites et ung martinet ⁹¹⁰

Page 5

1. le tout en fer, prisé ensemble ung escu, cy i escu sol
2. Item, en potz, platz, escuelles et autres ustanciles dhostel, le tout daitin,⁹¹¹
3. a esté trouvé la quantité de cent soixante et \dix sept/ livres, prisé
4. la livre trois solz tz, pour ce item: viii (8) escus Li (51) solz
5. En la premiere chambre dudit hostel et en laquelle ledit defunct est decedé,
6. a esté trouvé une grande couche de bois de noyer a hault dossier
7. et pilliers tournéz canneléz, ung lict et traversin garny de plumes,
8. une couverture de castelogne ⁹¹² verd, telle quelle,⁹¹³ ung ciel de tapisserye
9. facon de drap dor, garny de ses franges en crespine de laine
10. verde, blanche et rouge, trois custodies ⁹¹⁴ et une contenance (housse?)
11. de serge brodé, garnies de passementerie et molletz ⁹¹⁵ de laine blanche et
12. verde, avecq une paillasse de canevas, prisé le tout
13. ensemble, douze escuz sol, cy xii (12) escuz sol
14. Item, ung buffet de bois de noyer fermant a deux guichetz et
15. a clefz, garny de ses deux laiottes ⁹¹⁶ coulissant, vermoulu,
16. prisé deux escuz, cy ii écuz
17. Item, une paire de petitz chenestz de fer, garnis chacun de leur pomme

⁹⁰⁹ passoire

⁹¹⁰ bougeoir à accrocher au mur

⁹¹¹ d'étain

⁹¹² laine tissée en Catalogne, d'où le nom

⁹¹³ en l'état

⁹¹⁴ rideaux de lit

⁹¹⁵ franges

⁹¹⁶ tiroir

18. de cuivre, avecq une paire de molletz,⁹¹⁷ priséz ensemble xxv(25) Solz
19. Îtem, ung tableau ou est depeinct ung personnage, sur bois
20. garny de sa bordure ⁹¹⁸ dorée, prisé 1 escu
21. Item, ung tapis de buffet de drap verd, contenant ung aulnée
22. ou environ et demye aulne de large ou environ, tel quel
23. prisé xxx solz tz
24. Item \huict/ chaises caquetoires et trois placetz, couvertes de
25. tapisserie, priséz ensemble deux escuz ung tiers, cy ii escuz xx solz tz

Page 6

1. Item une table de bois de noier contenant quatre piedz de long ou environ, assise
2. sur deux treteaux, une chaise servant a sasseoir en table, garnie de
3. maroquin de Levant, a cloudz doréz et \quatre/ scabeaux aussy
4. de bois de noier, prisé le tout ensemble ii (2) escus xL(40) solz
5. Item, ung tapis de table contenant ung aulne et demie ou environ,
6. prisé i escu
7. Item, ung petit tableau ou est depeinct sur bois la Nativité
8. de Notre Seigneur, garny de sa bordure dorée, avecq ung autre viel
9. tableau ou est depeinct sur toile le Presche St Jehan Baptiste,
10. sans bordeure, une petite laiette de bois blanc, une
11. petite paire dhomoires a quatre estages servant a metre
12. livres, peincte de verd, ung petit bureau de bois de
13. chesn et une petite selle
14. basse de bois de haistre, prisé i escu
15. En une autre petite chambre joignant, a esté trouvé ung grand
16. coffre de bois de chesne, contenant six piedz de long ou environ,
17. fermant a une serrure et a clef, prisé i escu xx (20) solz tz
18. Item, ung autre cosfre de bois de chesne, contenant trois piedz de
19. long ou environ, fermant a une serrure a clef, deux chaises
20. caquetoires et ung scabeau aussi de bois de chesne,
21. prisé le tout ensemble i escu
22. Item, une couchette de bois de noier a hault dossier et
23. pilliers tournéz, ung lict et traversin de plumes,
24. une couverture de Casteloigne brodé, telle quelle,

⁹¹⁷ pincettes

⁹¹⁸ son cadre

25. ung ciel de tapisserie a locange,⁹¹⁹ trois custodes
26. et une contenance de serge verde et rouge et de
27. toile rouge xxxxx et une paillasse de canevas,
28. prisé le tout ensemble iiii (4) escuz sol
29. Item, une grande custode de serge verde et jaulne et
30. quatre oreillers garniz de plume, tant grandz que petitz,
31. priséz ensemble i escu

Page 7

1. Item, ung pett verrier a deux estages, de bois de chesne, une petite
2. selle de bois de noier tourné, une carte de toile ou est depeincte
3. la ville de Troye, ung autre tableau ou est peint sur toile Notre
4. Seigneur en croix, sans bordure, deux petites albalestres,⁹²⁰ une
5. pistolle,⁹²¹ ung fourniment,⁹²² ung bandage dalbalestre xxxxxxxx
6. xxxxxx et une partuisane,⁹²³ le tout tel quel, prisé le tout
7. ensemble i escu xx solz tz
8. Item, une grande couche de bois de noier, a hault dossier et pilliers
9. tournez, ung lict et traversin garni de plume, une couverture
10. de castelougne \blanche/, ung ciel de tapisserie a roze et
11. escailles, trois custodes et une contenance de serge
12. bleue et jaulne et une paillasse de canevas, prisé
13. le tout ensemble viii (8) escuz
14. Item, ung grand bancq a hault dossier et a couche, garny de
15. son marchepied, prisé i escu sol
16. Item, ung cosfre de bois de chesne de trois piedz et demy
17. de long ou environ, godronné,⁹²⁴ prisé xxx (3) solz
18. En une petite garderobbe joignant ladite petite chambre, a esté
19. trouvé ung paire dhomoires de bois de chesne fermans
20. a trois guichetz et a clef, prisée L(50) solz tz.
21. Item, ung xxxxxx lict et traverssin garny de plume,
22. couverture de drap couleur de minime⁹²⁵ et une paillasse de

⁹¹⁹ losange

⁹²⁰ arbalette

⁹²¹ petite arquebuse

⁹²² étui à poudre

⁹²³ halebarde

⁹²⁴ sculpté de plis arrondis, comme sur les colsfraises

⁹²⁵ gris très sombre, comme la robe des religieux Minimés

23. canevas, prisé le tout ensemble i escu
24. Item, ung viel petit coffre et une petite table de noier servant
25. a manger enfans et quatre et quatre petitz boutz d'ais et ung baston
26. de vieillesse de Brezil ⁹²⁶ garny dyvoire, prisé le tout
27. ensemble xx solz tz
28. Item, en une autre chambre au dessus xxxxxxxxxxxxxxxx
29. xxxxxxxx a esté trouvé une table de bois de chesne
30. de quatre piedz de long ou environ, assise sur deux treteaux,

Page 8

1. une chaise de bois de noier, servant a sasseoir a table, une
2. autre chaise de bois de chesne, percée et deux autres chaises
3. caquetoires (*en marge*: de chesne) dont lune couverte de tapisserie, prisé le tout
4. ensemble i escu xx(20) solz
5. Item, une grande table contenant huit piedz de long ou environ, sans treteaux
6. avec une grande ruele platte (*en marge*: une forme de bois de chesne servant a sasseoir a table) et une grande paire dhomoires
7. servant a mectre livres, a trois estages, prisé le tout ensemble i escu xv (15) solz
8. Item, ung buffet de bois de chesne fermant a deux guichetz
9. et a clef, garny de deux laiettes coulisses, tel quel
10. prisé ung escu, cy i escu sol
11. Item, une petite paire de chesnetz de fer, priséz xv(15) solz
12. Item, ung coffre de bois de chesne de quatre piedz de long
13. ou environ, fermant a clef, prisé xxx (30) solz
14. Item, une couchette de bois de noier, a hault dossier et pilliers
15. tournéz, une paillasse de canevas, ung lict et traversin
16. garny de plume, une couverture de castelougne rouge,
17. ung ciel, trois custodes et une contenance de serge rouge,
18. le tout tel quel, prisé ensemble iii (3) escuz xx (20) solz tz
19. Item, une autre couche de bois de noier a hault dossier et
20. pilliers tournéz, canneléz, garniz de son enfonceure ⁹²⁷ de latte,
21. ung lict et traversin garny de plume, une couverture de
22. castelougne verde, ung ciel de tapisserie facon de drap
23. dor, garny de ses franges et crespine de laine blanche,

⁹²⁶ bois rouge originaire du Brésil

⁹²⁷ fond de lit

24. verde et rouge, trois custodes et une contenance de
25. serge verde, prisé le tout ensemble viii (8) escuz sol
26. Item, une grande couche de bois de chesne a hault dossier
27. et pilliers tournéz, par pieces, sans enfonceure, prisé
28. quarente solz, cy xL (40) solz
29. Item, deux boisseaux et demy de \pois/, priséz
30. ensemble xxx (30) solz tz

Page 9

1. Item, ung tapis ou est peinct sur toile Notre Seigneur en croix et
2. autres figures, prisé i escu xxx (30) solz tz
3. Item, ung tableau peinct sur toille ou est depeincte l'Anonciation
4. Notre Dame xxxxx et ung autre viel tableau peinct sur toille i escu
5. Item, en une autre chambre a costé, a esté trouvé une table de
6. bois de chesne contenant six piedz de long ou environ, sise sur
7. deux treteaux, une selle servant a sasseoir a la porte
8. et trois ais, le tout de bois de chesne, prisé i escu
9. Item, au grenier dudit hostel a esté trouvé une table de bois
10. de chesne assise sur deux treteaux, contenant six piedz de
11. long ou environ, deux autres petites tables aussi bois de
12. chesne, deux scabeaux, une autre grande table, ung ais
13. fort, de huict piedz de long, deux petites homiores servant a
14. a mectre livres, faictes d'aix et deux petitz ais, prisé
15. le tout ensemble ii (2) escuz
16. Item deux ais de bois de chesne contenant douze piedz de long
17. ou environ, ung salloir garny de son couvercle, une cassa
18. de bois de haistre, prisé le t6ut ensemble xLv (45) solz
19. Item, une table quarrée servant a attacher contre la muraille,
20. de bois de haistre, ung berceau de bois de noier,
21. ung viel lendier,⁹²⁸ une paillasse de canevas et
22. \six/ pieces de corde servant a estendre du linge (*en marge*: deux barres bois
garnies et clouéz a hochetz)
23. prisé le tout ensemble i escu L(50) solz
24. Item, cinq futailles de demye queue⁹²⁹ a geule baie, ung

⁹²⁸ grand chenet de cuisine

⁹²⁹ d'un demi muid

25. auge de bois servant au metier de masson et
26. plusieurs ferailles, prisé le tout ensemble i escu x(10) solz
27. Item, ung matelas de futaine ⁹³⁰ et toile, garnie de cotton,
28. prisé i escu
29. Item, ung viel chaudron rompu, ung paire de tenailles,
30. une paisle,⁹³¹ ung moulinet ⁹³² a hausser vin et ung vent ⁹³³
31. a vanner grains, prisé le tout ensemble xxx (30) souz tz

Page 10

1. Item une paire dhomoires de bois de haitre, faicte d'ais servant
2. a mectre livres, a quatre estages, et deux ais de cinq
3. pieces de long ou environ, prisé le tout ensemble
4. cinquante solz L (50) solz
5. Ensuiuent les habitz.
6. Item une robe de drap tané,⁹³⁴ fourrée, a usage d'homme, telle quelle,
7. prisée i escu
8. Item, deux jupes, lune de serge, lautre camelot noir, aussi
9. telz quelz, priséz ensemble xxx solz
10. Item, une autre vielle jupe de serge noire, ung pourpoint
11. de serge noire, une paire de bas de chausses de felin
12. rouge et deux paires de chausses garnies de leur bas
13. de serge noire, le tout tel quel, prisé ensemble xxx solz
14. Item, ung saye ⁹³⁵ de veloux pelé, doublé de bouccasin ⁹³⁶
15. noir passémenté de passément de soye noire, prisé i escu xx solz
16. Item, dune ostade⁹³⁷ a usage de femme doublée de toile
17. blanche par le corps, bandée allentour dune
18. petite bande de veloux, telle quelle, prisé xL(40) souz
19. Item, deux pentes ⁹³⁸ de ciel, de tapisserie en meme
20. verdure, bestes et oyseaux (*en marge*: tel quelles), prisé i escu xx(20) solz
21. Item, une grande pente de ciel, de serge rouge

⁹³⁰ étoffe de fil et coton

⁹³¹ pelle

⁹³² treuil

⁹³³ ventoire

⁹³⁴ couleur tan = marron

⁹³⁵ casaque

⁹³⁶ doublure de coton

⁹³⁷ vetement d'étame ou serge

⁹³⁸ bande de retombée du ciel de lit

22. garnie de ses franges de laine, une grande
23. custode de camelot rouge, bleu et jaulne,
24. garnie de ses molletz de laine, avec une petit
25. tapis de toile verte, imprimé et une autre pente
26. de ciel, de tapisserie facon de locenge, prisé le tout (*en marge*: tel quel)
27. ensemble i escu xx(20) souz
28. Item, ung sacq de toile de chanvre, dans lequel
29. a esté trouvé la quantité de neuf livres de fil

Page 11

1. de chanvre.⁹³⁹ dune bande de satin noir et arriere pointcée, prisée iii escu
5. Item, ung manteau de serge de l... doublé par le collet
6. de veloux noir, aussi a usage d'homme, prisé ii escu xL(40) solz
7. Item, ung autre manteau de drap noir, aussi a usage d'homme
8. et doublé par le collet de veloux noir, tel quel, prisé i escu xL solz
9. Item, une robbe a usage d'homme de serge d'Orleans, doublée
10. de reveche ⁹⁴⁰ noire et par le collet, de veloux, prisée ii escuz xL(40) souz
11. Item, une robbe de drap noir garencé a jayx ⁹⁴¹ (*en marge*: a usage de femme) de veloux et a
12. queue, doublée de taffetas par bas allentour et par le
13. corps de toille, prisée viii (8) escuz xx(20) solz
14. Item, une autre robbe de drap d'Usseau,⁹⁴² noire, aussi a usage de
15. femme, a queue doublée de taffetas, bandée et
16. bordée allentour de veloux, avecq deux xxxxx chenettes
17. de soie dessus et doublée an teste par dedans de toille
18. et reveche, prisée vi (6) escuz
19. Item, une paire de poignetz de veloux doublé de serge et
20. en partie de satin, prisée trois escuz, cy iii escuz
21. Item, ung tapis de drap de ver contenant deux aulnes
22. et demye, lité allentour, prisé ii escuz xx(20) solz
23. Item, ung autre tapis de table tapisserie contenant
24. deux aulnes et demye, facon de drap dor, prisé iiiii escuz
25. Item, ung drap de deux lais de toille jaulne imprimée,

⁹³⁹ hemp

⁹⁴⁰ étoffe de déchets de laine

⁹⁴¹ traité à la garance pour briller comme du jais

⁹⁴² Ussel

26. prisée trente solz, cy xxx solz
27. Item, une juppe de taffetas noir, a usage dhomme,
28. doublée de reveche noire, prisée ii escuz
- Page 12
1. Item, deux paires de \mancherons/ a usage de femme .Lung
2. de veloux rouge et lautre de satin gris, deux bonnetz
3. quarréz descarlante rouge, avecq ung petit bonnet (*en marge*: a enfant)
4. de veloux cramoisy, galonné de galon dor. Et ung
5. petit chapeau de castol ⁹⁴³ a usage dhomme, prisé le
6. tout ensemble i écu xxx(30) solz
7. Item, deux pentes de ciel de tapisserie rehaussée
8. de soie, a bestes et oyseaux et meme verdure,
9. garny de ses franges de laine et crespine et molletz
10. de soye jaulne, prisées iiii (4) écuz
11. Item deux pentes de ciel, de tapisserie, faictz de
12. drap dor, non parfaicte ⁹⁴⁴ ny garnie, avecq la garniture
13. dune grande chaise servant a sasseoir a table et la
14. garniture dune autre chaire caquetoire. Ladite grande
15. chaise, réhaussée de soye, prisée ensemble iiii (4) écuz
16. -Item, ung morceau de camelot xxx de Turquie, noir, contenant
17. quatre aulnes, prisé iii (3) écuz
18. Item, trois morceaux de veloux, lung noir a fondz de
19. satin figuré, contenant trois quartiers. Le deuxiesme
20. de veloux rouge cramoisy, contenant demye aulne
21. et le troisieme de veloux jaulne et bleu raié, contenant
22. demye aulne, prisé le tout ensemble ii écuz xx solz
23. Item, ung morceau de taffetas, picqué de soye jaulne
24. sur du cotton, contenant ung aulne trois quartz, prisé i écu
25. Item, deux paires de brassieres de femmes en couches,
26. lune de taffetas blancq bandé de veloux blanc
27. par le collet et par les manches, lautre de taffetas
28. blanc picqué de soie sur du cotton, avecq deux pieces
29. de pareilles estoffes, aussi a usage de femme et

⁹⁴³ castor

⁹⁴⁴ finie

30. ung petit corps de satin de Burges, prisé le

31. tout ensemble xL (40) solz

Page 13

1. Item, ung petit jupon de camelot de soye noire, garny de

2. ses manches de taffetas noir moucheté, avecq ung petit

3. hault de chausses, facon de greques de satin moucheté,

4. prisé xL (40) souz tz

5. Item, ung tour de cheminée de tapisserie, facon de drap dor,

6. garny dune petite frange de laine rouge, bleue et blanche,

7. avecq une autre petite pente de ciel, de tapisserie

8. facon de locenge, garnye dune frange rouge, prisé

9. le tout ensemble xL (40) souz tz

10. Item, deux morceaux de drap verd, lung contenant ung aulne et demy

11. et laultre ung aulne trois quartz de demye aulne de long

12. chacun ou environ, prisé ensemble i écu

13. Item, une paire de brassieres de creze blanc, a usage de

14. femme, bandé allentour de veloux blanc et doublée de fuze

15. blanche, prisée xxx solz

16. Item, ung tour de cheminée de drap verd, contenant deux aulnes

17. ou environ et de demy quartier de large ou environ . Une coquille ⁹⁴⁵

18. de veloux cramoisy garnye de toille dor et de son?

19. prisé ensemble xxx(30) solz

20. Item, ung feutre de chapeau garny de son cresse et doublé de

21. reveche noire, avecq deux calottes, lune de soye

22. noire et laultre de taffetas noir, tel quel,

23. prisé ensemble xx(20) solz

24. Item, ung tapis de table, de drap verd, contenant deux

25. aulnes et ung quart, prisé xL (40) solz

26. Item, une petite couverture de drap rouge, prisée xii (12) solz

27. Item, une robbe de drap tané, a usage dhomme, non doublé,

28. telle quelle, prisée xx(20) solz

Page 14

1. Ensuyvent les bagues et joyaulx,

2. vaiselle dargent, trouvez audit hostel

⁹⁴⁵ coiffure de femme

3. Premièrement ung chappellet garny de sa croix et perle. Une
4. paire de brasselets. Une chesne, une oualle?, six
5. boutons, huict marques, quatre anneaulx, lung ung
6. mariage auquel est enchassé un saphi et ung petit
7. rubi, lautre ung petit diamant, au troisieme
8. ung petit rubi et au quatrieme une perle, avecq
9. une estruite.⁹⁴⁶ Le tout dor et poisant ensemble
10. ung marc, trois gros, prisé lonce: huict
11. escus cinquante cinq solz tz Lxxiiii (79) écus xL (40) solz tz
12. Item, deux couppes, une petite escuelle et trois
13. fourchettes, le tout dargent et doré par les
14. garnisons. Huict cuilliers dont l'une xxx
15. ayant une ratissoire au bout, une monstre, trois
16. chaines de demy ceinct. Et ung hochet garny de
17. sa chaine et trois sonnettes (*en marge*: avec quinze petitz boutons). Le tout aussi dargent
18. et poisant ensemble xxxxxxx six marcs moings
19. ung once, prisé le marc a six escus trente cinq
20. solz tz xxxviii (38) écus xL (40) solz
- 21.
22. Ensuit le linge
23. Et p... six chemises de toille de chanvre, a usage
24. dhomme dont quatre a colletz a freze et les autres deux
25. a bande, prisez ensemble i écu xL (40) solz

Page 15

1. Item, unze chemises dont huict de chanvre et trois
2. de lain,⁹⁴⁷ telles quelles, prisées ensemble i écu xx(20) solz
3. Item, six nappes de toille de chanvre, contenant chacune deux
4. aulnes de long, prisées ii écuz
5. Item, douze taies dorilliers de chanvre, telles quelles,
6. prisées ensemble xxv (25) solz
7. Item, dix serviettes de toille de chanvre, prisées L (50) solz tz
8. Item, trois serviettes de toille de lain ouvrées,⁹⁴⁸ telles

⁹⁴⁶ désigne un bijou

⁹⁴⁷ lin

⁹⁴⁸ ouvragées

9. quelles et trois couvrechefz de toille de chanvre;
10. priséz ensemble xx solz
11. Item, dix sept mouchoirs de toille de chanvre et lain,
12. prisé ensemble xx solz
13. Item, quatorze coiffes de nuict, a usage dhomme,
14. quatre petites calottes de toille blanche et
15. trois frezes de colletz, le tout de toille de chanvre
16. a usage dhomme, prisé ensemble xxx solz tz
17. Item, une douzaine de draps de toille de chanvre
18. de cinq aulnes chacun, priséz ensemble vi (6) écus
19. Item, six autres draps de toille de chanvre, de deux
20. lays xxxxxxxx, noeufz, priséz iii écus xL (40) solz tz
21. Item, quatre autres draps de chanvre de deux
22. lays, priséz ensemble i écu xx solz
23. Item, une douzaine dautre draps de toille de chanvre,
24. de lan et demy, telz quelz, priséz ensemble iii écuz

Page 16

1. Item six autres drapz de toille de chanvre noeufz,
2. prisez ensemble ii écus xL (40) solz
3. Item, deux autre drapz de toille de chanvre, telz quelz,
4. de lay et demy, priséz xL (40 solz)
5. Item, ung manteau destuve de toille de chanvre
6. prizé xv (15) solz tz
- 7.
8. Du mercredy xveme jour dudit mois de juillet
9. continuant ledit inventaire, a esté par lesdits notaire
10. inventorié ce que dessous.
11. Item, six nappes de toille de chanvre de deux aulnes
12. de long, prisées ensemble ung escu et demy, cy i escu v (5) deniers
13. Item, trois autres bappes de deux aulnes de long ou
14. environ, aussi de toille de chanvre, prisées xxx solz
15. Item, deux douzaines de serviettes aussi de toille de chanvre,
16. prisées i écu xL (40) solz
17. Item, trois douzaines de serviettes aussi de toille de
18. chanvre, prisées ensemble ii écuz

19. Item, deux douzaines de petites serviettes de toile de
20. chanvre, telles quelles, prisées ensemble xL (40) solz
21. Item, une petite robe et trois paires de brassieres de
22. futaine, ung petit garde robe de toile de chanvre,
23. deux petitz bonnetz et deux paires de manche, aussi
24. de futaine, trois chemises et brassieres, deux tours ⁹⁴⁹
25. de laine et cinq tabliers denfant, huict bavettes
26. le tout de toile. Et trois petitz bonnetz de futaine
27. aussi servans a enfant, priséz le tout ensemble xL (40) solz

Page 17

1. Item, cinq chemises a brassieres de toile de chanvre a usage
2. de femme, telles quelles et quatre couvrechefz aussi de toile de
3. chanvre a usage de femme, avecq une veille chemise a homme,
4. le tout tel quel, prisé le tout ensemble xxx solz
5. Item quatre douzaines de chauffoirs de toile de chanvre, telz quelz,
6. prisé ensemble xxx solz
7. Item, deux autres douzaines de petitz chauffoirs aussi de toile
8. de chanvre, telz quelz, priséz ensemble viii solz
9. Item, une douzaine de touailles a mains ⁹⁵⁰ et six tabliers de cuisine
10. de toile de chanvre et estoupe, priséz ensemble xx(20) solz
11. Item, huict aislezes ⁹⁵¹ de toile de chanvre, telles quelles, prisées
12. ensemble xxx (30) solz tz
13. Item, une piece de toile de chanvre, contenant vingt aulnes de
14. long et aulnée de large, prisé l'aulnée xxxxxx douze solz,
15. pour ce, cy iiii (4) escuz
16. Item, une douzaine de serviettes en pieces blanches a demy fleur,
17. prisée i écu xx solz tz
18. Item, une petite piece de toile de chanvre, contenant ung aulne
19. trois quart de long et ung aulne de large, prisée xviii (18) solz
20. Item, trois drapz de toile de chanvre de lay et demy. Et
21. deux autres de parelhe toile et de deux lays, priséz ensemble ii écuz
22. Item, ung grand coutty ⁹⁵² de lict, facon de Flandres, prisé avecq

⁹⁴⁹ écharpe

⁹⁵⁰ essuie mains

⁹⁵¹ alése

⁹⁵² coutil

23. le coutty dung orillier iiii écu
24. Item, cinq petites chemises a garçon et cinq a usage de
25. fille, le tout de toile de chanvre, prisées ensemble i écu
26. Item, deux vieilles nappes, avecq six ailezes et ung chauffoir,
27. le tout de toile de chanvre et tel que, prisé ensemble xL solz

Page 18

1. Item, deux douzaine de serviettes ouvrées en pieces. Et une
2. autre douzaine aussi de toile de lain et en pieces plaine,⁹⁵³
3. prisé le tout ensemble iiii écu ...
4. Item, deux douzaines de serviettes de lain ouvrées, a demy
5. usées, prisées ensemble ii écu
6. Item, deux autres \douzaines/ de serviettes de lain, plaines, prisées ii écu xx solz
7. Item six nappes xxxxx de toile de lain dont cinq
8. ouvrées et lautre plaine, prisé ensemble i écu xL (40) solz
9. Item, trois drapz de toile de lain, de douze lays chacun, priséz
10. ensemble iii écu
11. Item, trois nappes de toile de chanvre, noeufves, contenant chacune
12. deux aulnes de long ou environ, prisées i écu
13. Item, six serviettes de lain, de collation,⁹⁵⁴ prisées ii écu
14. Item, trois autres serviettes de colleur, de lain, damassées avec
15. deux autres aussi de toile de lain plaine, prisées i écu
16. -Item quatre serviettes de buffet de toile de lain ouvrées
17. prisées ensemble xL (40) solz
18. Item, deux bavettes de lict, lune toile de lain et lautre
19. de toile de chanvre, avecq deux taies dorillier aussi de
20. toile de lain, prisé le tout ensemble i écu
21. Item, cinq mouchoirs de toile de lain, arriere pointe ⁹⁵⁵ et a
22. houpettes, avecq une couche . Une testiere, ung tour de
23. de linge, le tout servant a porter enfans au fondz,⁹⁵⁶
24. prisé le tout ensemble xL (40) solz
25. Item quatre colletz de toile de lain plissez, sans freze. Ung
26. autre aussi de toile de lain, ung mouchoir de toile

⁹⁵³ unie

⁹⁵⁴ de table

⁹⁵⁵ fichu d'épaules, pointu dans le dos

⁹⁵⁶ au fondement, aux fesses

- 27. de lain ouvragé de soie noire, prisé ensemble x solz
- 28. Item, quatre drapz de toille de chanvre, de deux layes, uséz
- 29. priséz ensemble ii écuz

Page 19

- 1. Item, quatre autres draps aussi de toille de chanvre, de lay x (*dix*)
- 2. et demy chacun, priséz ensemble i écu x deniers
- 3. Item, huict nappes de toille de chanvre, de plusieurs grandeurs,
- 4. priséz ensemble ii écuz x deniers
- 5. Item, six serviettes et une nappe de toille de lain, ouvrées,
- 6. prisé le tout ensemble ii écuz v (5) solz
- 7. Item, une nappe de gros lain et neuf serviettes aussi de
- 8. lain et chanvre, plaines et ouvrées, prisé le tout ensemble i écu x deniers
- 9. Item, ung morceau de thoile noeufve contenant ung aulne, avecq
- 10. trois serviettes aussi de thoille de chanvre et deux
- 11. couvrechefz dhomme, prisé le tout ensemble xix (19)
- 12. Item, ung manteau destuve avecq une chemise a usage dhomme
- 13. le tout de thoille de chanvre et tel quel, prisé ensemble xx solz
- 14. Item, a esté trouvé en la boutique dudit hostel ung contour de
- 15. bois de chesne de xxx trois piedz et demy de long ou environ,
- 16. garny de deux laiettes coulisses, prisé i écu
- 17. Item, vingt quatre ais servant a mectre livres et marchandise
- 18. de papier, tant grandz que petitz, priséz ensemble xx solz
- 19. Item, ung grand scabeau, une selle longue de bassin
- 20. avecq deux autres petites selles servant a sasseoir
- 21. aupres du feu, le tout de bois de chesne et haistre,
- 22. prisé le tout ensemble xv(15) solz
- 23. Item, deux ...baux servant a, ung grand
- 24. et ung petit, prisé ensemble xxv (25) solz
- 25.
- 26. Ensuivent les meubles trouvéz en une maison sise
- 27. au village de Jantilly lez Paris ⁹⁵⁷
- 28. Premièrement une couche de bois de poirier a hault dossier et

Page 20

- 1. pilliers tournéz, une paillasse de cont..., une couverture de

⁹⁵⁷ Chantilly les Paris?

2. tapisserie en meme brodure, ung ciel de thoile peincte au dessus,
3. garny de frange et de laine, trois custodes et une contenance de serge
4. jaulne, rouge et bleue, prisé le tout ensemble ii écuz
5. Item une table de bois de chesne, contenant trois piedz et demy de
6. long ou environ, assise sur sa chaise a coffre, deux formes
7. et deux scabeaux, aussi de bois de chesne servans a
8. sasseoir a table, prisé le tout ensemble i écu xx solz
9. Item, ung grand banc servant a sasseoir a table, garny de
10. sa barre. Une forme et une chaise, le tout de bois de
11. chesne, servant aussi a sasseoir a table, prisé le
12. tout ensemble xL (40) escuz
13. Item, une petite dhomoir de chesne fermant a
14. deux guichetz et a clef . Une petite forme basse, ung
15. petit coffre et ung placet, le tout aussi de bois de
16. chesne, prisé le tout ensemble x L (40) solz
17. Item, une paire de chesvetz a ruelle et contre cottiers,⁹⁵⁸
18. ung gryot, une lescheffrite et des molletz, le tout de
19. fer, prisé le tout ensemble xL (40) solz
20. Item, une couchette de bois de chesne a hault dossier
21. et pilliers tournéz, ung lict garny de plume, une couverture
22. de thoile verde et bleue et ung ciel de serge verde
23. et rouge, garnye de ses franges, prisé le tout ensemble i écu xx(20) solz
24. Item, ung petit tapis de cheminée de camelot bleu, jaulne
25. et blanc, une thoilette rouge et une contenance de serge
26. rouge, avecq ung reschault, prisé le tout ensemble vii (7) solz vii deniers
27. Item, une couchette de bois de chesne a hault dossier et des
28. pilliers, une table de six piedz de long ou environ, assise
29. sur deux treteaux de bois de chesne et ung verrier dozier,
30. prisé le tout ensemble xL (40) solz
31. Tous lesdits meubles cy dessus, telz quelz.
32. Item, en potz, platz, escuelles et autres ustanciles dhostel,
33. a esté trouvé la quantité de sept livres, prisé la
34. livre: trois solz. Pour celuy xxi(21) solz tz

⁹⁵⁸ côté contre le mur

1. (1 paragraphe barré et repris ensuite)
- 2.
3. Du jeudy xxvii eme (27) jour du mois davril audit an,
4. continuant ledit inventere, a esté inventorié ce que ensuit.
5. Scavoir les lettres et tiltres.
6. -Item, ung contrat du Chatellet de Paris, signé Chappellan et
7. Arnor en datte du premier mars mil Vc Li (1551) contenant les promesses
8. de mariage faictes, traictées et accordées entre lesdits deffunctz
9. Guillaume Lebé et Loise Lambert jadis sa femme xxxxxxxx
10. xxxxxxxxxxxx aux conventions et douaire portéz par ledit contrat,
11. inventorié sur icelluy ung
12. Item, ung autre contract xxxxxx du Chatellet de Paris signé Chappellan,
13. en datte du premier jour de janvier mil Vc iiii xxi (1581) contenant les
14. promesses de mariages faictes et accordées entre lesdits Claude
15. Andrenas et Madeleine Lebé sa femme, en faveur du quel et
16. pour y parvenir ledit deffunct Guillaume Lebé son pere auroit promis
17. xxxxxx leur donner, bailler et paier la somme de neuf cens escus
18. sol en deniers comptant pour les causes et ainsi quil est conté
19. audit contract, en fin duquel est le quictement de ladite somme
20. de neuf cens escus sol, signé dudit Chappellan, datté du
21. xix eme (19) jour dudit mois de janvier audit an, inventorié sur ledit
22. contrat deux
23. Item, unes ⁹⁵⁹ lettres faictes soubz le scel de la ville de Paris, signées
24. Baretton, en date du huictiesme jour de septembre m Vc Li (1561) par lesquelles
25. le Sr Noel Lebé marchant drapier demeurant audit Troies avoyt
26. baillé et transporté par tiltre deschange et audit deffunct Guillaume
27. Lebé, la moictié divisée dune maison, droictz, aisances et
28. appartenances dicelle, comme elle se poursuit et comporte, assise a Paris
29. Rue de Beauvais, faisant le coing de ladite rue et de la rue St
30. Jehan de Latran,⁹⁶⁰ dont lautre moictié apartenoit audit deffunct
31. Guillaume Lebé par la succession de feu son pere, ainsi
32. que le tout est plus au long conté audites lettres, inventoriéz

⁹⁵⁹ au pluriel = une paire, deux

⁹⁶⁰ Dans le quartier de la Sorbonne. correspond à l'actuelle rue des Ecoles

33. sur icelles trois

Page 22

1. Avec lesquelles lettres estoit les antienes lettres dacquisition
2. de ladite maison faicte par Guillaume Lebé laigné, de Marie Racyot
3. en datte du troisieme jour de mars mil Vc cinquante ung (1551), signé Garnyer
4. et Pechon.
5. Item, ung contract du Chatellet de Paris en datte du jeudy dixieme jour
6. de janvier mil Vc Lxxii (1572), signé Franquelon et Croisot, contenant Messire
7. Anthoine le Cirier evesque d'Avranches doie, de leglise de Paris,
8. de Guillaume le Cirier son frere escuier gentilhomme servant
9. ordinaire de Monseigneur le duc d'Allancon, avoir vendu, cédé
10. transporté et promis garantir audit deffunct Guillaume Lebé une maison, petite
11. cour et appartenances, en laquelle pend pour enseigne 'la Grosse Escriptoire'
12. assise a Paris en la rue St Jehan de Latran et ladite vente avoit
13. esté faicte aux charges et moienant le pris et some de dix huit
14. cens livres tz qui en auroit esté lors paiée, ainsi en fin
15. duquel est la saisine de ce prinse, signée Foullon et la
16. ratification dicelle vente faicte par ledit Guillaume le Cirier, en datte
17. du xeme (10) jour davril audit an ml Vc Lxxii (1572) signé desdits Franquelon et
18. Croiset, inventoriés sur ledit contract quatre
19. Item, trois pieces xxxxxxxx et parchemin attachés ensemble. Le premier
20. signé Belot et Nynlon, en datte du samedi xxiieme (22) jour de septembre mil Vc
21. soixante seze (1576), par lesquelles apert: messire Francois le Cirier, conseiller
22. du roy en son privé conseil et court de Parlement et president es requestes
23. dicelluy et dame Jehanne Jucquet sa feme, avoir baillé et transporté
24. a tiltre de vente et promis garantir ausdits deffunctz Guillaume Lebé et Loise
25. Lambert, lors sa feme, deux corps entretenans et jognans lun
26. laultre, assis a Paris rue St Jehan de Beauvais ou souloit pendre
27. pour enseigne 'la Pomme de Pin' et ledit bail avoir esté fait
28. aux charges et moienant huitz vingtz ($8 \times 20 = 160$) six livres treze solz quatre
29. deniers tz de rente annuelle que lesdits Lebé et sa femme en auroient lors
30. promis paier et continuer aux termes, selon et ainsi que le tout
31. est plus au long contenu et décrit audit contract, en fin duquel est
32. la saisine de ce prinse, signé Foullon.
33. La seconde signée Cayard et Boreau en datte du mardy second

34. de juillet mil Vc soixante dix sept (1577), par laquelle apert ledit Sieur
35. conseiller le Corier et sa femme avoir baillé et transporté par
36. exchange aux chanoynes et chappelains de Saint Maur des
37. Fossez lesdites huict vingtz (160) six livres treze solz quatre
38. deniers tz de rente pour les si ainsi quil est contenu esdites
39. lettres.

Page 23

1. La troisieme signée Dubois et Chappelain, en datte du mardy premier
2. fevrier mil Vc iiii xx trois (1583) contenant les chanoynes et
3. chappelans de Saint Maur des Fossez avoir receu dudit deffunct Guillaume
4. Lebé, tant en son nom que comme tuteur de ses enfans et de ladite feu
5. Loise Lambert, la somme de xxxv six cens soixante six
6. escus deux tiers pour le rachapt et admortissement desdites huict
7. vingt (160) six livres treze solz quatre deniers tz de rente. Ainsi
8. inventoriés sur lesdites trois pieces cinq
9. Item, deux contractz du Chatelet de Paris, lung datté du xxeme jour de may mil Vc
10. iiii xx huict (1588) signé Jacques le Noir, contenant ledit deffunct Guillaume Lebé.
11. au nom et comme tuteur et curateur des enffans myneurs xxxxxxxxxxxxxxxxxxx
12. d'ans, de luy et de ladite feu Loise Lambert, Claude Andrenas et
13. Madelaine Lebé sa femme et Jehan Canelat et Margueritte Lebé sa femme,
14. avoir recu de Ysmael Lambert chirurgien et varlet ordinaire du roy,
15. la somme de vi xx (120) livres et xx solz sur et tant moins de la somme de iii c xxxiii (333) escutz
16. pour la quatrieme partie et portion appartenant aux enffans de ladite feu
17. Loise Lambert, au pris de la vente faicte audit Ysmael Lambert
18. dune maison, court et jardin assise pres la ville Saint Denis en France
19. et pour le surplus desdits iii c xxx iii (333) écus xx solz, ledit Ysmael Lambert auroit
20. baillé, ceddé et transporté audit deffunct Lebe et ses enfans seze
21. escus deux tiers de reste que luy estoient \deubz/ par Cornet
22. xxxv boullanger demeurant au faulx bourgs et Jacques Aneson.
23. Et ledit contract signé le Vasseur et le Rey, en datte
24. du septiesme jour de janvier mil Vc iiii xx six (1586), par lequel ledit M°
25. Lambert docteur en medecine, Anne Lambert et en leurs noms
26. ledit deffunct Guillaume Lebe, audit nom et comme tuteur de ses enffans

27. et de ladite feue Loise Lambert jadis sa femme et encores tous chacun
28. eulx faisant fors de M° Nicolas Lambert leur pere xxxxx chirurgien
29. et varlet de chambre du roy et Mr Ysmael Lambert leur frere,
30. auroient baillé et transporté a tiltre de rente audit
31. Corier boullanger, une maison, lieux, appartenances, assise es faulx
32. bourgts St Jacques en la grand rue et ce moienant a
33. seze escus deux tiers de rente annuelle et perpetuelle que ledit
34. Corier en avoyt promis paier et continuer aux termes, selon
35. et ainsi que le tout est plus au long contenu et ... audit
36. contract, inventorié sur les deux susdites lettres, si
37. sus inventorisées, lesquelz contractz lesdits Lebé et Andrenas ...
38.
39.
40. (deux lignes trop pales, illisibles)

Page 24

1. Item, unes lettres dudit Chatellet signée Chappellain et Chappellain, en
2. datte du septiesme jour de mars mil Vc Lx viii (1568) par lesquelles Sr Jacques
3. Marchant, marchand bourgeois de Paris et Ysabeau le Fevre sa femme,
4. auroit vendu, constitué et promis garantir, paier et continuer chacun pour
5. le tout, sans division, audit deffunct Guillaume Lebe, vingt livres tz
6. de rente sur les heritages et biens, soubz la faculté de rachat
7. et moienant la somme de iic x (210) livres tz quilz en auroient lors receu dudit
8. deffunct. Ainsi avec lesquelles estoient deux tiltres
9. nouveaux prisséz de ladite rente, Inventoriéz sur lesdits biens
10. deux seulz pour le tout (#) sept
11. Item, unes lettres de vente du Chatelet de Paris, signée Deprast, dattée
12. datte et an, du xxvii eme (27) mil Vc xL viii (1548) contenant avoir esté adjudgé
13. a Guillaume Lebé une petite maison et lieux assis a
14. Gentilly, comme plus offrant et dernier encherisseur pour la
15. somme de deux cens livres tz estoit
16. le proces verbal de distribution des deniers de ladite vente. Inventoriez
17. sur lesdites lettres de vente, pour le tout huict
18. Item, ung contract du Chatellet de Paris, en datte du xxvi eme (26) jour de
19. fevrier mil Vc soixante neuf (1569), signé Chappellain et Chappellain
20. contenant, Noel Darthins marchand demeurant a Gentilly avoir vendu et

21. promis garantir audit deffunct Guillaume Lebé une maison
22. ainsi quelle se comportoit, assise audit Gentilly au lieudit
23. le Clos Benilde . Item ung petit jardin et vigne contenant deux
24. quartes xxx ou environ, joignant ladite maison xxxx et
25. ung demi arpent de vignes assis derrier ledit jardin. Et ladite
26. vente avoir esté faicte aux charges et moienant la somme de deux
27. cens huict livres deux solz quil en avoit recu dudit deffunct, ainsi quil
28. est escript audit contract. Inventoriez sur icelluy neuf
29. Item, ung contract dudit Chatellet signé Vallet et Crozon, en datte
30. du xxix eme (29) fevrier mil Vc cinquante ung (1551) contenant Claude Dube
31. marchand papettier a Paris, avoir vendu et promis garantir audit deffunct
32. xxxxx Guillaume Lebe, ung quartier de vignes ou ... une piece
33. assise au lieudit les Los Genade au terroir de Gentilly. Et ladite vente
34. avoir esté faicte aux charges et moienant la somme de xxi (21) livres quil en avoit
35. recu ainsi et xxxxxxxxxxxx au dos duquel
36. est la saisine de ce payé. Inventoriez audit dos dix

(*en marge:*) En inventorian

lesquelles lettres, lesdits

Lebe et Andrenas

ont dict que les

arrerages de ladite rente

leur sont deubz

depuis le premier

juillet iiiixx et

neuf (89)

jusques au dernier

decembre iiiixx

xiii (93) et depuis le

premier jour mil

Vc iiixx xvii (1597).

Paraphes

Page 25

1. Item une ceddulle en papier, signée Richet, en datte du

2. xix eme (19) jour de juillet mil Vc iiiii xx sept (1587), par laquelle

3. le Sieur Jehan Richet marchand libraire et M° imprimeur a promis

4. devoir audit deffunct Guillaume Lebe, la somme de soixante neuf
5. escus vingt solz et neuf deniers tz pour les causes et a prendre au terme
6. declarez en ladite ceddulle. Inventorié au bas dicelle unze
7. Item, une autre ceddulle signée comme la precedente, en datte
8. du xxiiii eme (24) jour dudit mois de juillet mil Vc iiiix sept (1587) contenant
9. ledit Jehan Richet devoir audit deffunct Guillaume Lebe la somme
10. de cent quatre vingtz sept livres dix solz tz pour les causes
11. et a paier au terme declaréz en ladite ceddulle. Inventoriée
12. au dessoubz dicelle douze
13. Item, une ceddulle en papier, signée Adrian le Roy, en datte
14. su xixeme (19) jour d'avril mil Vc iiiix xvi (1596), contenant le soubzsigné
15. devoir audit feu Guillaume Lebe la somme de soixante deux
16. escuz trente trois solz tz pour les causes conttenues en ladite
17. ceddulle. Inventoriée au dessoubz dicelle treize
18. Item, une ceddulle en papier, signée comme la preceddente,
19. escripte au dos de quelques parties, en datte du cinquiesme
20. jour de septembre mil Vc iiiix xi (1591), par laquelle le soubzsigné
21. confesse devoir audit deffunct Lebe la somme de vingt neuf
22. escus quarante solz xxx a paier au terme declarez en ladite
23. ceddulle. Inventoriée au bas dicelle quatorze
24. Davantage, lesdits Lebe et Andrenas ont déclaré que sur le
25. pappier journal dudit deffunct leur pere, il apert que ledit
26. Adrian le Roy doit encores, outre ce, la somme de xxx dix escus
27. vingt cinq solz .
28. Item une ceddulle en pappier, en datte du xxixeme (29) jour de juillet
29. mil Vc iiiix xi (1591) signée Jehan Corbon, contenant le soubzsigné
30. Jehan Corbon libraire a Paris, comme tuteur des enffans de feu
31. Thomas Bremet, vivant aussi libraire, devoir audit deffunct
32. Lebe la somme de soixante six livres pour les causes et a paier
33. au terme declarez en ladite ceddulle. Inventoriée
34. au bas dicelle quinze
35. Au dos de laquelle apert avoir esté sur ce reçu huit
36. escus quarante huit solz.

Page 26

1. Item, une ceddulle en papier signée Perier, en datte du

2. deux janvier mil Vc iiiixx cinq (1585), par laquelle apert: Come
 3. Perier debvoir audit deffunct Lebe la somme de trente ung
 4. escus et trente solz tz pour les causes et a paier au terme
 5. declaréz en ladite ceddulle. Inventoriée au dessoubz dicelle seize
 6. Item, une ceddulle en papier, signée René Nyvelle et
 7. R. Nyvelle, en datte du xxvii eme (27) jour de mars mil Vc iiiixx xviii (1598),
 8. par laquelle apert les soubzsignéz debvoir audit feu
 9. Lebe, la somme de trente cinq escus pour les causes et
 10. a paier au terme declaréz en ladite ceddulle. Inventoriée
 11. sur icelle dix sept
 12. Item, ung brevet dudit Chatellet, en datte du xxvieme (26) jour de juin
 13. mil Vc iiiixx xi (1591), signé Denis Duval et
 14. xxx contenant Denis Duval marchand libraire a Paris debvo[ir]
 15. audit deffunct Lebe la somme de quarante escus quarante
 16. solz tz pour les causes et a paier au terme contenuz audit
 17. brevet. Inventorié au bas dicelluy dix huict
 18. Item, une sentence des juges et consulz de ceste ville de Paris,
 19. en datte du vingtiesme jour de fevrier mil Vc iiiixx xi (1591), signée
 20. L....., contenant Mamert Patisson marchand libraire a Paris
 21. avoir esté condampné paier audit deffunct Lebe la
 22. somme de deux cens vingt ung escus six solz contenu en sa
 23. ceddulle du xxixeme (29) juin mil Vc iiiixx cinq (1585) et vingt sept
 24. escus dix solz pour vente de fonte dimprimerie
 25. et avoir esté condampné es despens, taxéz a seze
 26. solz. Avec laquelle sentense estre la susdite ceddulle,
 27. inventoriée sur icelle et sur ladite sentence, lune comme lautre
 28. dix neuf
- (*en marge:*) Davantage, lesdits
 Lebe et Andrenas ont
 déclaré que outre
 le contenu en ladite sentence,
 ledit Mamert Patisson
 debvoit audit deffunct
 Lebe leur pere, la
 somme de quinze livres,

ainsi quil apert par son
papier journal.

1. Item, ung brevet dudit Chatelet, signé Prevosteau, Charles
2. et Fardeau, en datte du sixiesme jour de juillet mil Vc iiiixx
3. neuf (1589), contenant Estienne Prevosteau imprimeur libraire
4. a Paris, debvoir audit deffunct de cinquante sept
5. escus treze solz pour les causes et a paier au terme
6. declairez audit brevet. Inventorié sur icelluy vingt
7. Au dos duquel apert avoir esté sur ce receu trente
8. sept escus treize solz tz, a plusieurs fois.
9. Davantage, lesdits Lebe et Andreas ont déclaré que outre le
10. contenu audit brevet, ledit Prevosteau doit encores audit deffunct
11. Lebe leur pere, la somme de quinze escus sol, ainsi quil
12. apert sur son papier journal .

Page 27

1. Item, trois obligations du Chatelet de Paris. La premiere signée
2. Fardeau et Charles, en datte du xxvi eme (26) jour de septembre mil Vc
3. iiiixx huict (1588). La seconde, signée Belot et Fardeau, en datte
4. du neufviesme jour doctobre mil Vc iiiixx xii (1592). Et la troisieme signée Charles
5. et Francois, en datte du xiii eme (13) juillet mil Vc iiiixx seize (1596) . Par
lesquelles
6. le sieur Denis Binet M° imprimeur a Paris debvoit audit deffunct
7. Guillaume Lebe la somme de soixante quinze escus dix neuf solz tz
8. pour les causes et a paier au terme y declaréz. Inventoriéz
9. sur lesdites trois obligations, lune comme lautre. vingt ung
10. En inventariant lesquelles trois obligations, lesdits Lebe
11. et Andrenas ont declairé quil ne reste deub du contenu
12. dicelles sinon que la somme de trente cinq escus quinze
13. solz six deniers, ainsi quil apert sur le papier journal
14. dudit deffunct.
15. Item, ung brevet dudit Chatelet, signé Felesac et de Saint Vaast,
16. en datte du xv eme (15) jour de mars mil Vc iiiixx xv (1595) contenant
17. Guillaume Anuray marchand libraire a Paris et Gaspard Cure
18. marchand de vins, demeurant Rue St Martin, chacun pour le tout,

19. debvoir audit deffunct Guillaume Lebe, la somme de quatre
20. vingtz escus sol, pour les causes et a paier au terme declairéz
21. audit brevet, au dos duquel apert avoir esté sur ce receu a
22. plusieurs fois, jusques a soixante escus sol. Inventorié audit
23. dos vingt deux
24. Item, la sentence donnée des juges et consulz de ceste ville de Paris,
25. en datte du xxvii eme (27) jour daoust mil Vc iiiix xi (1591), signée Genres, contenant
26. ledit Consolat avoir este condampné paier audit deffunct Lebe
27. la somme de escus tz pour les causes et au terme declairéz, au bas
28. de laquelle apert quavoit esté receu par ledit deffunct la somme
29. de huict escus sol . Inventorié vingt trois
30. Lesdits Lebe et Andrenas ont dit que outre ladite somme, ledit
31. Leon Camelat doit encores audit deffunct trois escus
32. sept solz, ainsi quil est escript sur le pappier journal dudit
33. deffunct.
34. xxx
35. xxx
36. xxx
37. xxxxxxxxxxxxxxxxxxxxxxx
38. (bas de page très pale et flou, mais barré)

Page 28

1. xxx
2. Item, ung contract du Chatelet de Paris, en datte du xiii eme (13) octobre
3. mil Vc iiiix dix (1590), signé Lusson et Leynoir, par lequel apert
4. Simon Calvarin marchand, bourgeois de Paris et Anthoinette
5. Leynoir sa femme, chacun pour le tout, debvoir audit deffunct Guillaume
6. Lebe, la somme de cent soixante dix huict escus quarante
7. sept solz neuf deniers tz pour les causes et a paier
8. au termes declairez audit brevet. Inventorié sur iceluy xxiiii (24)
9. Avec lequel sont attachez plusieurs exploictz precedans,
10. sentences, de biens et declarations de despans
11. et autres pieces. En inventoriant lequel contract, lesdits Le-
12. be et Andrenas ont declairé quil nest plus deub de tout ce,
13. sinon que la somme de cent trente huict escus dix sept

14. solz neuf deniers.
15. Davantage, lesdits Lebe et Andrenas ont declairé que
16. par le papier journal dudit deffunct, il apert estre
17. deub ce que disent.
18. Scavoir par ledit Jacques Dupuis, cinq escus douze solz.
19. Par Pierre Fieffe marchand libraire, ung escu quarante cinq solz.
20. Par Pierre Luillier marchand libraire, cinq escus vingt sept solz.
21. Par ung Mr Lesleu marchand de biens, six escus quarante solz.
22. Par Pierre Bourgeois et parties, quatre escus .
23. Par le Sieur Leger Delas marchand imprimeur, vingt six escus trente ung .
24. Par Arnoul Titan et par parties, trente six escus dix solz.
25. Par le Sieur Baptiste Dupins, quatre escus sol.
26. Par le Sieur Michel Souyns et parties, seize escus cinquante ung solz.
27. Par Arnoul Cottrier M° imprimeur, neuf escus vingt quatre solz.
28. Par le Sieur Philipes Dupin marchand libraire, la somme de
29. unze escus deux solz six deniers.
30. Item, ung cahier de papier contenant huict fueilletz
31. escriptz, escriptz fort prez et quelque peu sur le neuvieme,
32. signé sur iceluy Jehan Carbon, en datte du sixiesme
33. jour de aoust mil Vc iiiixx xviii (1598) contenant xxxxxxxxx
34. linventaire par luy mené, description (*trop pale, illisible*)

Page 29

1. et estimation faicte par ledit Jehan Carbon de xxxxx
2. tous les livres trouvéz apres le decez dudit deffunct,
3. inventoriés sur ledit neufviesme fueillet, audessoulz dudit
4. seing vingt cinq
5. Item, deux feuilles de papier attachés ensemble,
6. dont les deux premiers fueilletz sont escriptz entierement
7. et quelque sur le troisieme, signé Lois Rion, datté
8. du xxiii eme (23) jour de juillet mil Vc iiiixx xviii (1598), contenant
9. la description et prisée faicte par ledit Rion de toute
10. la marchandise de pappier qui sest trouvée apres
11. le decez dudit deffunct. Inventoriez au dessoubz du
12. seing vingt six
13. Item, ung cahier de papier contenant quatre feuilles

14. de papier attachées ensemble. Dont les six premiers
15. fueilletz sont escriptz entierement et presque la moictié
16. du septiesme, datté du vingtiesme juillet audit an
17. mil Vc iiiixx xviii (1598), signé Jacques Duclos et Jacques de
18. Sanlecque, contenant la description et prisée par eulx
19. faicte des matrices, moules, poinçons et autres ustancilles
20. servans a la fonte de lettres dimprimeries, trouvéz apres
21. le decez dudit deffunct. Inventoriéz audessous des seings vingt sept
22. conté lesquelles descriptions lesditz Lebe et
23. Andrenas nont voulu estre escriptes par
24. et se sont absentéz xxxxx Inventoriés
25. toutes lesquelles matrices, marchandises, papiers et
26. livres, lesdits Lebe et Andrenas nont voulu estre mis
27. par au present inventaire et se sont contentéz que desdites
28. descriptions et prisées soient ainsi inventoriées/
29. Lesquelles ont esté paraffées par ledit le Noir notaire, en
30. la fin des susdites pages.
31. Lesdits Lebe et Andrenas a cause
32. des sucessions de feuz M° Nicolas Lambert et Margueritte
33. (illisible)

Page 30

1. La quatriesme partie et portion dune maison assise a rue Ma.....
2. parolles. Item une maison assise es faulboulx Notre Dame
3. des Champs, ou souloit pendre pour enseigne 'les Verdz
4. Gallandz'. Item une arpen de prey xxx prins en une
5. piece contenant quatre arpens. Item la moictié dun pré
6. contenant ung arpen, nommé le pré Saint Martin. Item, ung
7. arpen dix neuf perches de terre . Et trois arpens
8. unze perches, en une piece. xxxxxxxxxxxx Le tout assis
9. près leglise Saint Remy les Saint Denis en France.
10. Item, ung arpen de terre que souloit estre en vigne,
11. assis au terroir de Pierfontz.
12. Signatures

Page 31 (page de couverture)

Inventaire des biens

de feu Guillaume

Lebé.

Année 1597

Appendix G: The evidence of type distribution from the examined editions

The evidence from printed editions examined as discussed in Chapter 2

Type face→ Place and Printer↓	Hb1(S)	Hb2(R)	Hb3(S)	Hb4(S)	Hb5(R)	Hb6(S)	Hb7(R)	Hb8(R)	Hb9(S)	Hb10(S)
Antwerp Plantin Moretus							1			1
Antwerp Vidua & Moretus										1
Augsburg, Mangius				1?						1
Bad Windsheim Redelhamer										1
Basel Frobenius, Zifroni						1				3
Basel Waldkirch	1			1?	1	2				5
Constantinople Usque		1								
Cracow, Prostitz		1			1	1	6			2
Cremona Conti		3			1	1?	1?			6
Ferrara Usque		2								
Ferrara unknown							2			
Frankfurt an der Oder Unknown										1
Freiburg im Breisgau Zifroni	3				4	1?				6
Hamburg Unknown				1	1?					
Hanau Henne				2	2					3
Hanau Averi										1
Mantua Unknown		2					1?			1
Mantua Rufinelli		1								2
Padua Pasquato				1						
Paris Le Bé II						1				
Riva di Trento Marcaria										2
Sabbionetta Foa		1								
Venice Meir di Parenzo Carlo Querini		1			1					
Venice Zanetti		2					2	1		5

Type face→ Place and Printer↓	Hb1(S)	Hb2(R)	Hb3(S)	Hb4(S)	Hb5(R)	Hb6(S)	Hb7(R)	Hb8(R)	Hb9(S)	Hb10(S)
Venice Griffio/Grypho					1	1	2			2
Venice Bragadin and di Gara	1				1		1			2
Venice Bragadin and Parenzo						1				
Venice di Gara	1				2	1	1			4
Venice Giustiniani	1	10			6		1	2		1
Venice Adelkind	1				2	1				
Venice Bragadin	4	2		2	5	3	2		2	2
Venice di Cavalli				2	3		2			7
Venice, Parenzo					3					
Venice Unknown				1	2	1				
Venice Zifroni										1
Verona delle Donne							1			
Total	12	26	0	8	36	16	23	3	2	60

The evidence from printed editions examined as discussed in Chapter 3

Type face→ Place and Printer↓	Hb11 (S)	HB12 (S)	Hb13 (S)	HB14 (S)	HB 15 (S)	HB 16 (R)	Hb 17 (S)	Hb18 (R)	Hb19 (S)	Hb19 (S)	Hb20 (R)	Hb21 (S)
Amsterdam Jansson	1?			1								
Amsterdam, unknown				1								
Antwerp Plantin Moretus	1	3	3	4								
Basel Ambrosius Frobenius	1?											
Leiden Raphlengius		2	2	3								
Leiden Raphlengius and Le Maire			1	1								
Leiden Le Maire				2								
Mantua, unknown				1								
Paris Guillaume II Le Bé	2	3	3	2		1				1	1	

Type face→ Place and Printer↓	Hb11 (S)	HB12 (S)	Hb13 (S)	HB14 (S)	HB 15 (S)	HB 16 (R)	Hb 17 (S)	Hb18 (R)	Hb19 (S)	Hb19 (S)	Hb20 (R)	Hb21 (S)
Paris Guillaume Morel	2											
Paris Pierre l'Huillier	1											
Paris Jean Bienné	3											
Paris Antoine Vitré	1	1	1	1								
Paris Pierre Variquet	1											
Paris Imprimerie Royale	1	1	1	1								
Paris Laqueray		1	1	1								
Paris Briasson and Duranc				1								
Venice Di Gara	1?											
Venice di Cavalli				1?								
Venice Zifroni	1			1								
Total	16	11	11	21	0	1	0	0	0	1	1	0

The evidence from printed editions examined as discussed in Chapter 4 (Part 1)

Type face→ Place and Printer↓	Hb2 3 (S)	Hb2 4 (S)	Hb2 5 (S)	Hb2 6 (S)	Hb2 7 (S)	Hb2 8 (S)	Hb2 9 (S)	Hb3 0 (S)	Hb3 1 (R)	Hb3 2 (S)	Hb3 3 (S)	Hb3 4 (R)	Hb3 5 (S)	Hb36 (R)
Amsterdam Unknown									1					
Antwerp Plantin/Moretus		1									1	4	1	
Basel Ambrosius Frobenius													1	
Basel Waldkirch	6											2		
Constantinople Usque			1											
Constantinople. Soncino		1												
Constantinople. Nachmias and Caspota				1										
Constantinople. Nachmias			2	1										
Constantinople. Unknown			5											
Cracow Prostitz		1											1	
Cracow Unknown		1												
Cremona Conti		3											1	
Ferrara			1											

Type face→ Place and Printer↓	Hb2 3 (S)	Hb2 4 (S)	Hb2 5 (S)	Hb2 6 (S)	Hb2 7 (S)	Hb2 8 (S)	Hb2 9 (S)	Hb3 0 (S)	Hb3 1 (R)	Hb3 2 (S)	Hb3 3 (S)	Hb3 4 (R)	Hb3 5 (S)	Hb36 (R)
Usque														
Ferrara unknown			5	4										
Frankfurt Wust					1									
Frankfurt an der Oder Unknown					1									
Freiburg im Breisgau Zifroni													6	
Geneva Henri Estienne					1	2	2							
Geneva Paul Estienne						1	1		1					
Geneva Eustache Vignon						1	1		1					
Geneva Pierre de la Rouvière					1									
Geneva André Wechel heirs								2						
Geneva Jacob Stoer							1	1						
Giessen Kaspar Chemlin					1?									
Hanau Typographia Orientalis					1?	1	1							
Hanau Henne													1	
Isny Fagius												1		
Leiden Raphelengius												3		
Mantua Rufinelli		1											1	
Paris Simone de Colines							1							
Paris Laqueray		1											1	
Paris Gilles de Gourmont							1							
Paris Robert Estienne					5	5	8	2	8					
Paris Henri Estienne					1	1	1		1					
Paris Jean Bienné					1									
Pesaro Soncino		1												
Rome Blado et co											2?	1?	1	

Type face→ Place and Printer↓	Hb2 3 (S)	Hb2 4 (S)	Hb2 5 (S)	Hb2 6 (S)	Hb2 7 (S)	Hb2 8 (S)	Hb2 9 (S)	Hb3 0 (S)	Hb3 1 (R)	Hb3 2 (S)	Hb3 3 (S)	Hb3 4 (R)	Hb3 5 (S)	Hb36 (R)
Sabbionetta Foa		1											1	
Salonika Jabez		1												
Salonika Unknown				1										
Venice Aldus Manutius the elder		1?									1			
Venice Bomberg		10								1	13	11	8	1
Venice Tacuino		1												
Venice Bomberg and Adelkind		1										1	1	
Venice Adelkind		1											2	
Venice Meir di Parenzo Carlo Querini		1									1			
Venice Bragadin and di Gara		2										1	1	
Venice di Gara												4		
Venice di Gara and Adelkind													1	
Venice Dei Farri and Adelkind													1	
Venice Bragadin and Parenzo		1										1		
Venice di Gara		3										3		
Venice Giustiniani	6	2									3		10	
Venice Adelkind													1	
Venice Bragadin		4			1?							1	2	
Venice di Cavalli	1												4	
Venice Parenzo		3									3		1	
Venice Parenzo Querini		1												
Venice Unknown	1													
Venice Zanetti													3	
Venice Zifroni													1	
Venice		1												

Type face→ Place and Printer↓	Hb2 3 (S)	Hb2 4 (S)	Hb2 5 (S)	Hb2 6 (S)	Hb2 7 (S)	Hb2 8 (S)	Hb2 9 (S)	Hb3 0 (S)	Hb3 1 (R)	Hb3 2 (S)	Hb3 3 (S)	Hb3 4 (R)	Hb3 5 (S)	Hb36 (R)
Ziletti														
Total	14	45	14	7	13	11	17	5	11	1	26	32	50	1

The evidence from printed editions examined as discussed in Chapter 4 (Part 2)

Type face→ Place and Printer↓	Hb 37 (S)	Hb38 (S)	Hb39 (S)	Hb40 (S)	Hb41 (S)	Hb42 (S)	Hb43 (R)	Hb44 (R)	Hb45 (S)	Hb46 (R)	Hb47 (R)	Hb48 (S)	Hb49 (R)	Hb50 (A)	Hb51 (A)
Antwerp Plantin Moretus	3														
Barco Soncino															1
Basel Waldkirch		1													
Basel Georg Decker					1										
Basel Froben					1									9	
Basel Froben and Episcopus														4	
Basel Martin Wagner					1										
Constantin ople. Nacmias								1							
Constantin ople. Soncino								1							
Constantin ople. Unknown								2							
Cracow Prostitz		2?													
Cremona Conti				1?											
Fano Soncino								1	1						
Frankfurt Wechel															1
Geneva Officina Sanctandr eana		1?													
Leiden Le Maire	4														
Leiden Rapheleng ius	4														
Leiden Rapheleng ius and Le Maire	1														
Louvain Martens														1	
Paris Claue Chevallon			1												
Paris Jacques Bogard			1												
Paris Pierre			1												

Type face→ Place and Printer↓	Hb 37 (S)	Hb38 (S)	Hb39 (S)	Hb40 (S)	Hb41 (S)	Hb42 (S)	Hb43 (R)	Hb44 (R)	Hb45 (S)	Hb46 (R)	Hb47 (R)	Hb48 (S)	Hb49 (R)	Hb50 (A)	Hb51 (A)
Gautier															
Paris Martin le Jeune			3												
Pesaro, So ncino									1						
Piove di Sacco Cusi															3
Venice Bomberg	4							1			1				
Venice Bragadin and di Gara	1														
Venice, Giustiniani		3													
Venice Bragadin		1						1							
Venice di Cavalli		2													
Venice Parenzo				7											
Venice Unknown		1													
Venice Ziletti	1														
Total	18	11	6	8	2	0	0	7	2	0	1	0	0	14	5

Appendix H: The basic library documentation form

This is an example of a completed basic library documentation that was used for recording data from the examination of printed Hebrew editions.

VB to base 13/5/2011

Stephen Lubell/ PhD Researches
 Basic Library documentation Form
 Abbreviations: SS = Square Sephardic; RS = Rashi Script; SA = Square Ashkenazic; YS = Yiddish Script

Record Number:	
Date examined	27/1/2011
Repository	UCL SC
Shelfmark	SR MOCATTA QUARTO 1577.L2
Title	Rabbi Levi Ben Gershom רבי לוי בן גרשון - פירושי חומש
Nature of work	Biblical Commentary on the Pentateuch
Author	Rabbi Levi ben Gershom
Place of Publication	Venice
Printer	Bombard
Date	1577 (ת"ש) =
Format	130x21 cm Quarto 3
Colophon	הפוסט אהיה צניח ביהקבא' בענין פירוש הרב ר' לוי בן גרשון ז"ל וכו' ← on Field NP
Hebrew Type 1	SS unprinted on TP x = 5.5 MM & headings within text = Heb/SS/27 ✓
Hebrew Type 2	SS unprinted on TP x = 2.70 MM & headings within text
Hebrew Type 3	RS unprinted on TP x = 1.90 MM & occasional lines within text Heb/RS/28? ✓
Hebrew Type 4	SS unprinted Main Text on TP x = 1.70 MM 20: 85 MM; 11: 162 (C) of set Heb/SS/25 ✓

Hebrew Type 5	Heb S/S unpointed X = C ₁ ISM
Hebrew Type 8	
Hebrew Type 7	
Hebrew Type 8	
Hebrew Type 9	
Hebrew Type 10	
Photos	101-3862 → 3873
Notes	<p>✓ Heb 4. Hal Ext: characters $\text{ד}, \text{כ}, \text{ס}, \text{ז}$</p> <p>(Note typical Bombay $\text{כ} + \text{ז}$ lig. כז ✓)</p> <p>→ No evidence of ext ד at all!</p> <p><u>Note</u> Pronunciation in scriptos opp. TP Bought in Prague in כז?</p> <p>Agon: very clean parchment; no visible spaces seen</p>

Appendix I: The Estienne Hebrew Editions – 1539 to 1545

This appendix provides a listing of the known Hebrew editions printed by Robert I Estienne during the years 1539 to 1545, which includes the period of Guillaume I Le Bé's apprenticeship. The data is compiled from Lyse Schwarzfuchs and Antoine Coron, *Le livre hébreu à Paris au XVIe siècle: inventaire chronologique* (Paris: Editions de la Bibliothèque nationale de France, 2004) and Antoine Renouard, *Annales de l'Imprimerie des Estienne, ou, Histoire de la Famille des Estienne et de ses éditions*, (Paris: Jules Renouard & Cie, 1837).

Year	Title	Types used	References	Editions examined
1539 Between 17 June to 15 July 1539	Sophonias	Picard's Square Sephardic Hebrew on Two-Line Pica [Hb 4 mm] <i>Gros-Parangon</i> or <i>Palestine</i> (1543).	Schwarzfuchs No. 88	In BL 1.a.14 See comment on possible reprintings of same editions.
1539 Between 16 July to 14 August 1539	Michaeas	The first 'Estienne' Square Sephardic Hebrew on Two-line Pica [Hb 4 mm] or <i>Gros-Parangon</i> (1539). (In BL 1a14) Picard's Square Sephardic Hebrew on Two-Line Pica [Hb 4 mm] <i>Gros-Parangon</i> or <i>Palestine</i> (1543). In BnF Res-4-NFA 3	Schwarzfuchs No. 89	In BL 1a12-15, 1a14 and 1942g2 See comment on possible reprintings of same editions.
1539 Between 15 August to 12 September 1539	Nahum	Picard's Square Sephardic Hebrew on Two-Line Pica [Hb 4 mm] <i>Gros-Parangon</i> or <i>Palestine</i> (1543).	Schwarzfuchs No. 90	In BL 1a12-15, 1a14 See comment on possible reprintings of same editions.
1539 Between 15 August to 12 September 1539	Aggaeus	The first 'Estienne' Square Sephardic Hebrew on Two-line Pica [Hb 4 mm] or <i>Gros-Parangon</i> (1539).	Schwarzfuchs No. 91	In BL 1a12-15 1a14, 1942g2
1539 Between 26 August to 24 September 1539	Prophetia Isaiaie ספר ישעיה	The first 'Estienne' Square Sephardic Hebrew on Two-line Pica [Hb 4 mm] or <i>Gros-Parangon</i> (1539).	Schwarzfuchs No. 86	In BL 1a14 (Volume three of four)
1539 Before September 1539	Duodecim Prophetae (Hosea)	The first 'Estienne' Square Sephardic Hebrew on Two-line Pica [Hb 4 mm] or <i>Gros-Parangon</i> (1539).	Schwarzfuchs No. 87	In BL 1a12-15, 1a14 and BnF edition
1539 Between 13 October to 11 November 1539	Psaumes	?	Schwarzfuchs Bible A.T. Psaumes Hebr. 1539	See Schwarzfuchs No. 108 of 1540
1539	Habacuc	The first 'Estienne'	Schwarzfuchs No. 92	In BL 1a12-15.1a14,

<i>Year</i>	<i>Title</i>	<i>Types used</i>	<i>References</i>	<i>Editions examined</i>
Between 12 November to 11 December 1539		Square Sephardic Hebrew on Two-line Pica [Hb 4 mm] or <i>Gros-Parangon</i> (1539).		1942g2
1539 Dated 21 November 1539	Alphabetum Hebraicum/Alphabetu m Graecum	The first 'Estienne' Square Sephardic Hebrew on Two-line Pica [Hb 4 mm] or <i>Gros-Parangon</i> (1539).	Schwarzfuchs No. 84 Renouard/Annales 1539/No. 2	BL copy: 58.a.12 In BL 1a12-15
1540 Between 10 January to 8 February 1540	Ioel	The first 'Estienne' Square Sephardic Hebrew on Two-line Pica [Hb 4 mm] or <i>Gros-Parangon</i> (1539).	Schwarzfuchs No. 99	In BL 1a12-15, 1a14
1540 Between 10 January to 8 February 1540	Amos	The first 'Estienne' Square Sephardic Hebrew on Two-line Pica [Hb 4 mm] or <i>Gros-Parangon</i> (1539).	Schwarzfuchs No. 100	In BL 1a12-15, 1a14
1540 Between 10 January to 8 February 1540	Abdias/Ovadia (Premiere edition)	The first 'Estienne' Square Sephardic Hebrew on Two-line Pica [Hb 4 mm] or <i>Gros-Parangon</i> (1539).	Schwarzfuchs No. 101	In BL 1942g2, 1a14, 1942g2 Note second edition listed in Schwarzfuchs which has the same dates, but is probably a later printing (1543?)
1540 Between 10 January to 8 February 1540	Ionas (Premiere edition)	The first 'Estienne' Square Sephardic Hebrew on Two-line Pica [Hb 4 mm] or <i>Gros-Parangon</i> (1539). (1a14) Picard's Square Sephardic Hebrew on Two-Line Pica [Hb 4 mm] <i>Gros-Parangon</i> or <i>Palestine</i> (1543). In BnF Res-4-NFA 3 and BL 676e8 1542)	Schwarzfuchs No. 102	In BL 1a12-15 See comment on possible reprintings of same editions. Note second edition listed in Schwarzfuchs which has the same dates, but is probably a later printing (1543?)
1540 Between 15 August to 12 September 1540	Aggaeus (Premiere edition)		Schwarzfuchs No. 103	Note second edition listed in Schwarzfuchs which has the same dates, but is probably a later printing (1543?)
1540 Between 9 February to 8 March 1540	Zacharias	The first 'Estienne' Square Sephardic Hebrew on Two-line Pica [Hb 4 mm] or <i>Gros-Parangon</i> (1539).	Schwarzfuchs No. 104	In BL 1a12-15, 1a14, also LSE Rare Books
1540 Between 9 March to 7 April 1540	Malachias	The first 'Estienne' Square Sephardic Hebrew on Two-line	Schwarzfuchs No. 105	In BL 1a12-15 Appears to use Briquet WM 8090

<i>Year</i>	<i>Title</i>	<i>Types used</i>	<i>References</i>	<i>Editions examined</i>
		Pica [Hb 4 mm] or <i>Gros-Parangon</i> (1539).		throughout ...
1540 Between 5 July to 3 August 1540	Canticum Canticorum	The first 'Estienne' Square Sephardic Hebrew on Two-line Pica [Hb 4 mm] or <i>Gros-Parangon</i> (1539).	Schwarzfuchs No. 106	In BL 1a12-15
1540 Between 4 August to 1 September 1540	Prophetia Ieremiae	The first 'Estienne' Square Sephardic Hebrew on Two-line Pica [Hb 4 mm] or <i>Gros-Parangon</i> (1539).	Schwarzfuchs No. 107	In BL 1a12-15 and 1942g2
1540 Between 13 October to 11 November 1540s	Psalterium	The first 'Estienne' Square Sephardic Hebrew on Two-line Pica [Hb 4 mm] or <i>Gros-Parangon</i> (1539).	Schwarzfuchs No. 108	In BL 1a12-15 and 1a15 and 1942g2
1540 Between 4 August and 1 September 1540	Proverbia Salomonis	The first 'Estienne' Square Sephardic Hebrew on Two-line Pica [Hb 4 mm] or <i>Gros-Parangon</i> (1539).	Schwarzfuchs No. 109	In BL 1a15, and 1942g2
1540 Between 13 September 1539 and 1 September 1540	Daniel	The first 'Estienne' Square Sephardic Hebrew on Two-line Pica [Hb 4 mm] or <i>Gros-Parangon</i> (1539).	Schwarzfuchs No. 110	In BL 1a15 and 1942g2
1540	Biblia Latina (Hebraica, Chaldaea, Graecaque & Latina nomina virorum, mulierum etc)		Schwarzfuchs No. 111	New revised edition of 1532 (Schwarzfuchs No. 42)
1541 Between the 2 September 1540 and 21 September 1541	Bible (Ezechiel)		Schwarzfuchs p. 109	
1541 Between 2 September and 21 September 1541	Iob	The first 'Estienne' Square Sephardic Hebrew on Two-line Pica [Hb 4 mm] or <i>Gros-Parangon</i> (1539).	Schwarzfuchs No. 118	In BL 1a15 Appears to use Briquet WM 8090 throughout
1541 Between 2 September and 21 September 1541	Esdras/Nehemias	The first 'Estienne' Square Sephardic Hebrew on Two-line Pica [Hb 4 mm] or <i>Gros-Parangon</i> (1539).	Schwarzfuchs No. 119	In BL 1a15 and 1942g2
1541 18 February 1541 Ann. MDXLI XII Calend. Mar	Libri Moysi quinque		Schwarzfuchs No. 120bis	.
1542	Ezechiel		Schwarzfuchs No.	

Year	Title	Types used	References	Editions examined
Between 2 September 1540 and 21 September 1541 Dated 1542 on TP?			125	
1540? Between 2 September 1540 and 21 September 1542	Ezechiel	The first 'Estienne' Square Sephardic Hebrew on Two-line Pica [Hb 4 mm] or <i>Gros-Parangon</i> (1539).	Schwarzfuchs p. 106 (See Schwarzfuchs 125 of 1542)	In BL 1a15, 1942g2
1542 Between 11 September 1542 and 29 August 1543	Josue/Juges/Samuel 1-2/Rois 1-2		Schwarzfuchs p. 112	See Schwarzfuchs No. 145
1543	Alphabetum Hebraicum	Hb30 (S)?	Schwarzfuchs No. 131	8vo edition
1543	Bible A.T. Hebr 1543-1546		Schwarzfuchs p. 114	Second Hebrew Bible in 17 parts in 16mo
1543 Between 11 September 1542 and 29 August 1543	Bible A.T. Quinque Libri legis Contains: Genesis, Exodus, Leviticus, Numeri and Deuteronomium	Picard's Square Sephardic Hebrew on Two-Line Pica [Hb 4 mm] <i>Gros-Parangon</i> or <i>Palestine</i> (1543).	Schwarzfuchs No. 132	2x copies in BL: 1a12 examined (Volume one of four) In 4to Only Genesis has a proper TP 1a15 and 676e7 seen. Uses Picard Hebrews and Rashi on LB specimen
1543 Between 11 September 1542 and 29 August 1543	Bible A.T. Chroniques 1-2 Liber Paralipomenon	Uses Picard Hb28 (S)	Schwarzfuchs No. 133	In 4to BL: 1a13
1543 Between 29 October and 27 November 1543	Duodecim prophetae	Uses Hb27 (S), 31, 32 and RS34	Schwarzfuchs No. 134	In 16mo BL: 1942b13
1543 Between 29 October and 27 November 1543	Canticum Canticorum		Schwarzfuchs No. 135	In 16mo
1544	Alphabetum Hebraicum	Picard's Square Sephardic Hebrew on Two-Line Pica [Hb 4 mm] <i>Gros-Parangon</i> or <i>Palestine</i> (1543).	Schwarzfuchs No. 144	In 8vo Seen at Bnf:Inv res X 2603/2606
1544	Alphabetum Hebraicum		Schwarzfuchs p.120	In 8vo Edition Antoine Chevallier
1544 Between 11 September 1542 and 29 August 1543	Prophetiae priores Contains: Iosue, Iudicum liber, Samuel and Regum I)	Picard's Square Sephardic Hebrew on Two-Line Pica [Hb 4 mm] <i>Gros-Parangon</i> or <i>Palestine</i> (1543)	Schwarzfuchs No. 145	In 4to In BL 1a13 (Volume two of four) Uses Briquet WM 8090
1544 Between 26 January	Prophetia Isaiiae	Uses Hb28 (S), Hb29 (S) (Main text) and	Schwarzfuchs No. 146	In 16mo BL: 1942b13

<i>Year</i>	<i>Title</i>	<i>Types used</i>	<i>References</i>	<i>Editions examined</i>
and 24 February 1544		Hb34 (R)		
1544 Between 21 July and 19 August 1544	Prophetia Ieremiae	Uses Hb28 (S), Hb29 (S) (Main text) and Heb/SS/34	Schwarzfuchs No. 147	In 16mo
1544 Between 20 August and 17 September 1544	Prophetia Ezechielis	Uses Hb28 (S), Hb29 (S) (Main text) and Heb/SS/34	Schwarzfuchs No. 148	In 16mo
1544 Between 18 November and 15 December 1544	Iosue & Judices	Uses Hb28 (S), Hb29 (S) (Main text) and Heb/SS/34	Schwarzfuchs No. 147	In 16mo BL: 1942b12
1545	Samuel 1-2	Uses Hb28 (S), Hb29 (S) (Main text) and Heb/SS/34	Schwarzfuchs No. 160	In 16mo Sans adresse ni date BL: 1942b12
1545	Reges	Uses Hb28 (S), Hb29 (S) (Main text) and Heb/SS/34	Schwarzfuchs No. 161	In 16mo Sans adresse ni date BL: 1942b12
1545 Between 14 January and 12 February 1545	Psalterium	Uses Hb28 (S), Hb29 (S) (Main text) and Heb/SS/34	Schwarzfuchs No. 162	In 16mo BL: 1942b12
1545 Between 14 March and 12 April 1545	Proverbia Salomonis & Iob	Uses Hb28 (S), Hb29 (S) (Main text) and Heb/SS/34	Schwarzfuchs No. 163	In 16mo
1545 Between 12 May and 10 June 1545	Daniel & Esdras + Nehemia	Uses Hb28 (S), Hb29 (S) (Main text) and Heb/SS/34	Schwarzfuchs No. 164	In 16mo
1545	Biblia		Schwarzfuchs No. 165	In 8vo 2 volumes
1545	Canticum Canticorum		Schwarzfuchs p. 127	Charles Estienne In 4to

<i>Glyph</i>	<i>No. of Combination</i>	<i>Details of vowel/cantillation combination and frequency</i>
	26.	אָ
	27.	אֲ
	28.	אִ
	29.	אֵ
	30.	אֶ
	31.	אֻ
bet	32.	בּ בְ בִ בֵ בֶ בֻ
	33.	בֶּ בֵּ בִּ בְּ בֻּ בֶּ בֵּ בִּ בְּ בֻּ
	34.	בֶּ בֵּ בִּ בְּ בֻּ בֶּ בֵּ בִּ בְּ בֻּ
	35.	בֹ
	36.	בֹּ
	37.	בֹּ בֹּ בֹּ
	38.	בֹּ בֹּ
	39.	בֹּ בֹּ
	40.	בֹּ
	41.	בֹּ
	42.	בֹּ
	43.	בֹּ בֹּ בֹּ בֹּ
	44.	בֹּ
	45.	בֹּ
	46.	בֹּ בֹּ
	47.	בֹּ
	48.	בֹּ בֹּ
	49.	בֹּ
	50.	בֹּ
	51.	בֹּ בֹּ
	52.	בֹּ
	53.	בֹּ
	54.	בֹּ בֹּ
	55.	בֹּ
	56.	בֹּ
	57.	בֹּ
	58.	בֹּ

<i>Glyph</i>	<i>No. of Combination</i>	<i>Details of vowel/cantillation combination and frequency</i>
Gimmel	59.	גְּ גֵּ
	60.	גֶּ
	61.	גִּ
	62.	גֻּ
dalet	63.	דְּ דֵּ דִּ דִּ
	64.	דֶּ דִּ דִּ דִּ
	65.	דִּ דִּ
	66.	דִּ דִּ
	67.	דִּ ^o
	68.	דִּ דִּ
	69.	דִּדִּ
	70.	דִּי
	71.	דִּי
	72.	דִּי
	73.	דִּי
	74.	דִּי
	75.	דִּי
heh	76.	הְ הֵּ הִּ הִּ
	77.	הֶּ הִּ הִּ הִּ
	78.	הִּ הִּ הִּ הִּ
	79.	הִּ הִּ הִּ הִּ
	80.	הִּ הִּ
	81.	הִּ הִּ
	82.	הִּ הִּ
	83.	הִּ
	84.	הִּ
	85.	הִּ הִּ הִּ הִּ הִּ
	86.	הִּ
	87.	הִּ
	88.	הִּ
	89.	הִּ

<i>Glyph</i>	<i>No. of Combination</i>	<i>Details of vowel/cantillation combination and frequency</i>
	429.	תְּ
	430.	תֶּ
	431.	תִּ
	432.	תֵּ
	433.	תִּי
	434.	תִּתִּי
	435.	תִּי
	436.	תִּי
	437.	תִּי
	438.	תִּי
	439.	תִּי
	440.	תַּלְתַּל
Punctuation	441.
	442.	
	443.	----- -----

The Original text in Hebrew

- 1 בְּרֵאשִׁית בָּרָא אֱלֹהִים אֶת הַשָּׁמַיִם וְאֶת הָאָרֶץ:
- 2 וְהָאָרֶץ הִיְתָה תֹהוֹ וָבֹהוּ וְהַשָּׁמַיִם עַל־פְּנֵי תְהוֹם וְרוּחַ אֱלֹהִים מְרַחֶפֶת עַל־פְּנֵי הַמַּיִם:
- 3 וַיֹּאמֶר אֱלֹהִים יְהִי אוֹר וַיְהִי־אוֹר:
- 4 וַיֵּרָא אֱלֹהִים אֶת־הָאוֹר כִּי־טוֹב וַיִּבְרַךְ אֱלֹהִים בֵּין הָאוֹר וּבֵין הַחֹשֶׁךְ:
- 5 וַיִּקְרָא אֱלֹהִים לְאוֹר יוֹם וְלַחֹשֶׁךְ קָרָא לַיְלָה וַיְהִי־עֶרֶב וַיְהִי־בֹקֶר יוֹם אֶחָד: פ
- 6 וַיֹּאמֶר אֱלֹהִים יְהִי רָקִיעַ בְּתוֹךְ הַמַּיִם וַיְהִי מִבְדִּיל בֵּין מַיִם לְמַיִם:
- 7 וַיַּעַשׂ אֱלֹהִים אֶת־הַרְקִיעַ וַיִּבְרַךְ בֵּין הַמַּיִם אֲשֶׁר מִתַּחַת לְרָקִיעַ וּבֵין הַמַּיִם אֲשֶׁר מֵעַל לְרָקִיעַ וַיְהִי־כֵן:
- 8 וַיִּקְרָא אֱלֹהִים לְרָקִיעַ שָׁמַיִם וַיְהִי־עֶרֶב וַיְהִי־בֹקֶר יוֹם שֵׁנִי: פ
- 9 וַיֹּאמֶר אֱלֹהִים יִקְווּ הַמַּיִם מִתַּחַת הַשָּׁמַיִם אֶל־מְקוֹם אֶחָד וּתְרַאֶה הַיַּבְשָׁה וַיְהִי־כֵן:
- 10 וַיִּקְרָא אֱלֹהִים לַיַּבְשָׁה אָרֶץ וּלְמַקְנֵה הַמַּיִם קָרָא יַמִּים וַיֵּרָא אֱלֹהִים כִּי־טוֹב:
- 11 וַיֹּאמֶר אֱלֹהִים תִּדְשָׂא הָאָרֶץ דָּשָׂא עֵשֶׂב מִזֵּרַע וְרֵעַ עֵץ פָּרִי עֵשֶׂה לְמִינֹו אֲשֶׁר וְרֵעוּ־בֹ עַל־הָאָרֶץ וַיְהִי־כֵן:

- 12 אֲשֶׁר זָרְעוּבוּ לְמִינְהוּ וַיִּרְא אֱלֹהִים כִּי־טוֹב: וַתּוֹצֵא הָאָרֶץ דָּשָׁא עֲשׂוּב מִזְרִיעַ זָרַע לְמִינְהוּ וַעֲזַן עֲשׂוּה־פְרִי
- 13 וַיְהִי־עָרַב וַיְהִי־בָקָר יוֹם שְׁלִישִׁי: פ
- 14 וַיֹּאמֶר אֱלֹהִים זֶהי מְאֹרֶת בְּרַקִּיעַ הַשָּׁמַיִם לְהַבְדִּיל בֵּין הַיּוֹם וּבֵין הַלַּיְלָה וְהָיוּ לְאֹתוֹת וּלְמוֹעֲדִים וּלְיָמִים וְשָׁנִים:
- 15 וְהָיוּ לְמְאֹרֶת בְּרַקִּיעַ הַשָּׁמַיִם לְהַאִיר עַל־הָאָרֶץ וַיְהִי־כֵן:
- 16 וַיַּעַשׂ אֱלֹהִים אֶת־שָׁנֵי הַמְּאֹרֶת הַגְּדֹלִים אֶת־הַמְּאֹרֶת הַגְּדֹלִי לְמַמְשֶׁלֶת הַיּוֹם וְאֶת־הַמְּאֹרֶת הַקָּטָן לְמַמְשֶׁלֶת הַלַּיְלָה וְאֵת הַכּוֹכָבִים:
- 17 וַיִּתֵּן אֹתָם אֱלֹהִים בְּרַקִּיעַ הַשָּׁמַיִם לְהַאִיר עַל־הָאָרֶץ:
- 18 וְלִמְשַׁלׁ בַּיּוֹם וּבַלַּיְלָה וּלְהַבְדִּיל בֵּין הָאֹר וּבֵין הַחֹשֶׁךְ וַיִּרְא אֱלֹהִים כִּי־טוֹב:
- 19 וַיְהִי־עָרַב וַיְהִי־בָקָר יוֹם רְבִיעִי: פ
- 20 וַיֹּאמֶר אֱלֹהִים יִשְׂרָצוּ הַמַּיִם שָׂרָץ גֹּפֶשׁ תִּנְיָה וְעוֹף יַעֲוֹף עַל־הָאָרֶץ עַל־פְּנֵי רַקִּיעַ הַשָּׁמַיִם:
- 21 וַיִּבְרָא אֱלֹהִים אֶת־הַתַּנִּינִם הַגְּדֹלִים וְאֵת פְּלִגְפָשׁ הַחַיָּה הַרְמֻשָׁת
- אֲשֶׁר־שָׂרְצוּ הַמַּיִם לְמִינֵהֶם וְאֵת כָּל־עוֹף כְּנָף לְמִינְהוּ וַיִּרְא אֱלֹהִים כִּי־טוֹב:
- 22 וַיְבַרֵךְ אֹתָם אֱלֹהִים לֵאמֹר פְּרוּ וּרְבוּ וּמְלֵאוּ אֶת־הַמַּיִם בַּיַּמִּים וְהָעוֹף יִרְבַּ בָּאָרֶץ:
- 23 וַיְהִי־עָרַב וַיְהִי־בָקָר יוֹם חַמִּישִׁי: פ
- 24 וַיֹּאמֶר אֱלֹהִים תּוֹצֵא הָאָרֶץ גֹּפֶשׁ חַיָּה לְמִינָהּ כַּהֶמָּה וְרִמָּשׁ וְחַיִּתוֹ־אָרֶץ לְמִינָהּ וַיְהִי־כֵן:
- 25 וַיַּעַשׂ אֱלֹהִים אֶת־חַיֵּי הָאָרֶץ לְמִינָהּ וְאֶת־הַבְּהֵמָה לְמִינָהּ וְאֵת כָּל־רִמָּשׁ הָאֲדָמָה לְמִינְהוּ וַיִּרְא אֱלֹהִים כִּי־טוֹב:
- 26 וַיֹּאמֶר אֱלֹהִים גַּעֲשֶׂה אֲדָמָה בְּצַלְמִנוּ כְּדִמוֹתֵנוּ וַיִּרְדּוּ בְדָגַת הַיָּם וּבְעוֹף הַשָּׁמַיִם וּבַבְּהֵמָה וּבְכָל־הָאָרֶץ וּבְכָל־הַרְמָשׁ הָרֹמֵשׁ עַל־הָאָרֶץ:
- 27 וַיִּבְרָא אֱלֹהִים אֶת־הָאָדָם בְּצַלְמוֹ בְּצֶלֶם אֱלֹהִים בָּרָא אֹתוֹ זָכָר וּנְקֵבָה בָּרָא אֹתָם:
- 28 וַיְבַרֵךְ אֹתָם אֱלֹהִים וַיֹּאמֶר לָהֶם אֱלֹהִים פְּרוּ וּרְבוּ וּמְלֵאוּ אֶת־הָאָרֶץ וּכְבַשְׁתֶּהּ וַיִּרְדּוּ בְדָגַת הַיָּם וּבְעוֹף הַשָּׁמַיִם וּבְכָל־חַיָּה הָרֹמֵשׁ עַל־הָאָרֶץ:
- 29 וַיֹּאמֶר אֱלֹהִים הִנֵּה נֹתַתִּי לָכֶם אֶת־כָּל־עֵשׂוֹב זָרַע זָרַע אֲשֶׁר עַל־פְּנֵי כָל־הָאָרֶץ וְאֶת־כָּל־הָעֵץ אֲשֶׁר־כֹּף פְּרִיעֵץ זָרַע זָרַע לָכֶם וְהָיָה לְאֹכְלָהּ:
- 30 וְלִכְלֵל־תֵּיֵת הָאָרֶץ וּלְכַלֵּעוֹף הַשָּׁמַיִם וּלְכָלוֹ רֹמֵשׁ עַל־הָאָרֶץ אֲשֶׁר־כֹּף גֹּפֶשׁ חַיָּה אֶת־כָּל־יִרְק עֲשׂוּב לְאֹכְלָהּ וַיְהִי־כֵן:
- 31 וַיִּרְא אֱלֹהִים אֶת־כָּל־אֲשֶׁר עָשָׂה וְהִנֵּה־טוֹב מְאֹד וַיְהִי־עָרַב וַיְהִי־בָקָר יוֹם שֵׁשִׁי: פ

Psalms (Tehilim) Chapter 34

<http://www.sacred-texts.com/bib/tan/psa034.htm>

<i>Glyph</i>	<i>No. of Combination</i>	<i>Details of vowel/cantillation combination and frequency</i>
Aleph	1.	א
	2.	אֲ
	3.	אָ
	4.	אַ
	5.	אִ
	6.	אֵ
	7.	אֶ
	8.	אִי אֵי אֶי אֲי אָי אִי אֵי אֶי אִי אֵי אֶי
	9.	אִי
	10.	אֵי
	11.	אֶי
	12.	אִי
	13.	אֵי
	14.	אֶי
	15.	אִי
	16.	אֵי
	17.	אֶי
	18.	אִי
Bet	19.	ב
	20.	בֲ בִ בֵ בֶ בִּ בֵּ בֶּ בִּי בֵּי בֶּי בִּי בֵּי בֶּי
	21.	בִּי
	22.	בֵּי
	23.	בֶּי
	24.	בִּי
	25.	בֵּי
	26.	בֶּי
	27.	בִּי
	28.	בֵּי
	29.	בֶּי
	30.	בִּי
	31.	בֵּי
Gimmel	32.	ג
	33.	גֲ
	34.	גָ
	35.	גִּ
	36.	גֵּ
Dalet	37.	ד

<i>Glyph</i>	<i>No. of Combination</i>	<i>Details of vowel/cantillation combination and frequency</i>
	198.	עֶ
	199.	עֶ
	200.	עֶעֶעֶ
	201.	עֶ
	202.	עֶעֶעֶעֶ
	203.	עֶעֶעֶ
	204.	עֶ
	205.	עֶעֶעֶ
	206.	עֶ
	207.	עֶ
	208.	עֶ
	209.	עֶ
	210.	עֶ
	211.	עֶ
Tsadde	212.	צֶ
	213.	צֶ
	214.	צֶ
	215.	צֶ
	216.	צֶ
	217.	צֶ
	218.	צֶ
	219.	צֶ
	220.	צֶ
	221.	צֶצֶצֶ
Tsadde Final	222.	צֶ
Koph	223.	קֶ
	224.	קֶ
	225.	קֶ
	226.	קֶ
	227.	קֶ
	228.	קֶ
	229.	קֶ
Peh	230.	פֶ
	231.	פֶ
	232.	פֶ
	233.	פֶ
	234.	פֶפֶ
	235.	פֶ
	236.	פֶ
	237.	פֶ

- 12 לכוֹבְנִים שְׁמַעוּ־לִי יִרְאַת יְהוָה אֲלֹמֹדָבָם:
- 13 מִי־הָאִישׁ הַחֲפִיץ חַיִּים אֲתָב יָמִים לרְאוֹת טוֹב:
- 14 נִצֹר לְשׁוֹנֵן מִרַע וּשְׁפֹתָיו מִדַּבֵּר מִרְמָה:
- 15 סוֹר מִרַע וַעֲשֵׂה־טוֹב בְּקֶשׁ שְׁלוֹם וְרִדְפֵהוּ:
- 16 עֵינֵי יְהוָה אֶל־צַדִּיקִים וְאַזְנוֹי אֶל־שׁוֹעֲתָם:
- 17 פְּנֵי יְהוָה בַּעֲשֵׂי־רַע לְהַכְרִית מֵאֶרֶץ זָכָרָם:
- 18 צַעֲקוּ וַיהוָה שָׁמַע וּמְכַל־צְרוּתָם הִצִּילָם:
- 19 קָרוֹב יְהוָה לְנֹשְׁבְרֵי־לֵב וְאֶת־דֹּכָאֵי־רוּחַ יוֹשִׁיעַ:
- 20 רַבּוֹת רַעוֹת צַדִּיק וּמִפְּלֹם יִצְלִנּוּ יְהוָה:
- 21 שִׁמְרָ פֶלֶעֶצְמוֹתָיו אֶת־מְהִנָּה לֹא נִשְׁבְּרָה:
- 22 תְּמוֹתַת רָשָׁע רַעַה וְשִׁנְאֵי צַדִּיק יִאֲשָׁמוּ:
- 23 פּוֹדָה יְהוָה גַּפְשׁ עַבְדָּיו וְלֹא יִאֲשָׁמוּ כָּל־הַחֹסִים בּוֹ:

Appendix K: Typefounder's tools

The following list is part of a 'rough essay' compiled by Harry Carter in 1964 and was recently discovered amongst his papers in St Bride Library in London. He also commissioned a series of line drawings to complement the list for the three separate operations, which comprise tools known to him for punchcutting, typefounding and justifying. The earlier descriptions are to be found in Moxon and Fournier, both of which Harry Carter edited and which he drew on for this list.⁹⁶¹ Those marked with an asterisk* are peculiar to the operation. Carter also notes that 'a few were made in quantity and sold to typefounders, but most were home-made and belonged to the workmen', and furthermore that most of these were used at OUP during the period when Carter worked there. This list most likely reflects nineteenth-century practice, whereas the Fournier illustrations are more accurate representations of the type of tools available to Le Bé during the sixteenth century. A more recent list can be found in Paput, *La lettre/La Gravure du Poinçon typographique*, 1998. He lists the following tools and equipment required for cutting punches: files of various sizes, gravers of different sorts and sections, an Arkansas polishing stone, a polishing square, a drawing or tracing box, a magnifying glass on a stand with enlargement of about three times and a diameter of 3.5 cm which is reduced to 1.5 cm with a mask in order to eliminate distortion within the field of vision, a wooden peg, a vice, a metal saw, a T Square, an adjustable square, a type scale calibrated in points, a burnisher, an eyepiece (jeweller's loop), a brush, sharpening stones, a small sheet of gelatine or 'rhoidoid' (cellulose acetate Plastic), modelling clay or wax, a kiln capable of heating up to at least 800 degrees centigrade, pouncing powder, wine vinegar and a cork.⁹⁶²

Punchcutter's Tools

- Hacksaw
- Files: flat and pillar coarse files; Medium files; flat, half-round, three cornered, donkey back, needle, and knife-shaped fine files
- *Gauges for the face; also Italic Gauges: A piece of thin brass with slots used for testing the sizes of various letters and the slope of italics. The standing italic gauge is a piece of brass cut with the right angle. A good surviving example is from the Athias Cabinet in Amsterdam.
- Stones and slates
- *Facing tool: For grinding the faces of punches on stones
- Gravers and scrapers
- Chisel
- Scriber

⁹⁶¹ Moxon, Carter, and Davis, *Mechanick Exercises*, pp. 88-98 and Fournier and Carter, *Fournier on Typefounding*, pp. 301-303, Plates III and IV

⁹⁶² Paput, *La lettre/La Gravure du Poinçon typographique* pp. 22-23

- Twist (or pump) drill
- Eyeglasses
- Counterpunches
- *Counterpunch placer: A device used by some punchcutters for driving counterpunches into punches
- Emery and emery sticks
- Stone slips
- Blowpipe
- Wig: This is most probably an implement made of twisted and folded wire, and was used to hold a punch over a heat source during tempering. After a punch is hardened it is cleaned and then gradually heated until the surface shows a pale straw yellow, at which time it is quenched for a second time in water.⁹⁶³
- Seager cones: A series of cones used to indicate the temperature inside a furnace or kiln. The cones are made from different mixtures of material each of which softens at a different temperature. The drooping of the vertex is an indication that the known softening temperature has been reached and allow the furnace temperature to be estimated. However, the punchcutter also knows the correct temperature for tempering the steel punch by the colour of the steel. See above.
- Flattening (?) punch
- Script punch
- Smoking tool for positioning smoke proofs
- Candle or lamp for producing smoke proofs

Typefounder's tools

- *Moulds
- Copper hammers for justifying the mould
- *Ladles
- Rubbing stones
- *Letter sticks: Device used to hold type between operations
- *Ploughs
- Nicking plough
- Bearding plough

⁹⁶³ Email clarification from Stan Nelson, November 2013. I am grateful for his input on this list.

- *Height to paper gauge
- *Thickness gauge, body gauge
- Dressing sticks*

Justifier's Tools

- Files: flat, coarse, fine
- York stone
- *Striking stake. Matrices formerly had the punches struck in with a hammer. In the nineteenth century various striking tools were used to force the punch into the copper matrix.
- Hammers
- Emery powder
- Gauges: depth*, overlap*, turning, Height to paper, Italic*. The depth gauge is used to test the depth and horizontality of the strike. The overlap gauge was used to test the position of the strike in relation to the side and head of the matrix. The turning gauge was a device to test whether the sides of the matrix were parallel. The Justifier's gauge was used to test the flatness of the face and the height of type cast during justification.
- (Set) Square
- Eyeglasses
- Moulds and Ladles: For justifying trial types



Fig App. K.1: Face gauge as described by Harry Carter (St. Bride Library)



Fig App. K.2: Face gauge with type sizes marked from the Athias Cabinet (Drawer 33) Original size of each brass is about 9 cm. This is most probably from the seventeenth century. (The University of Amsterdam Special Collections)

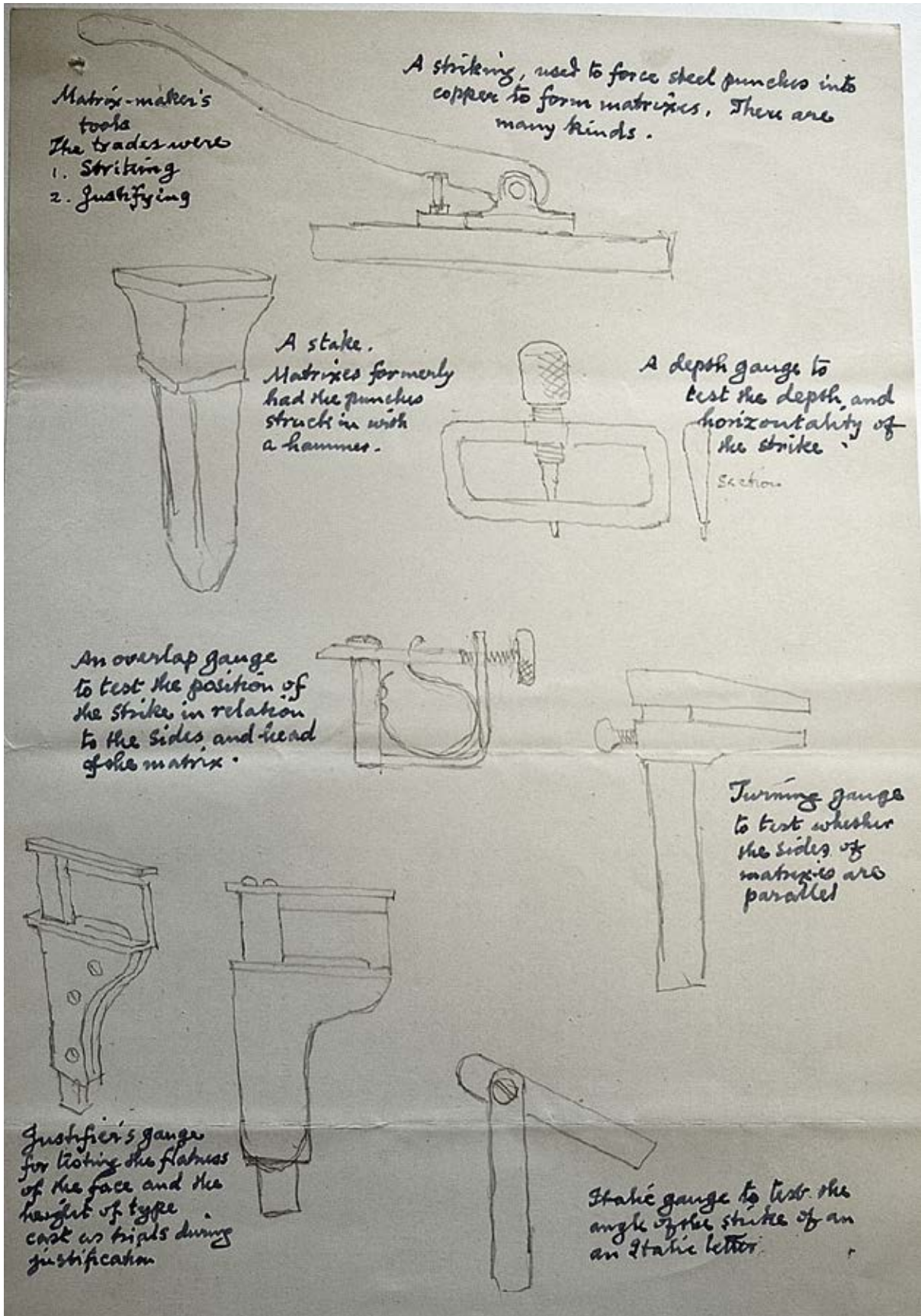

Fig. App. K.3: Illustrations and descriptions from Harry Carter's Typesetter's tools (St. Bride Library)

Type-caster's tools

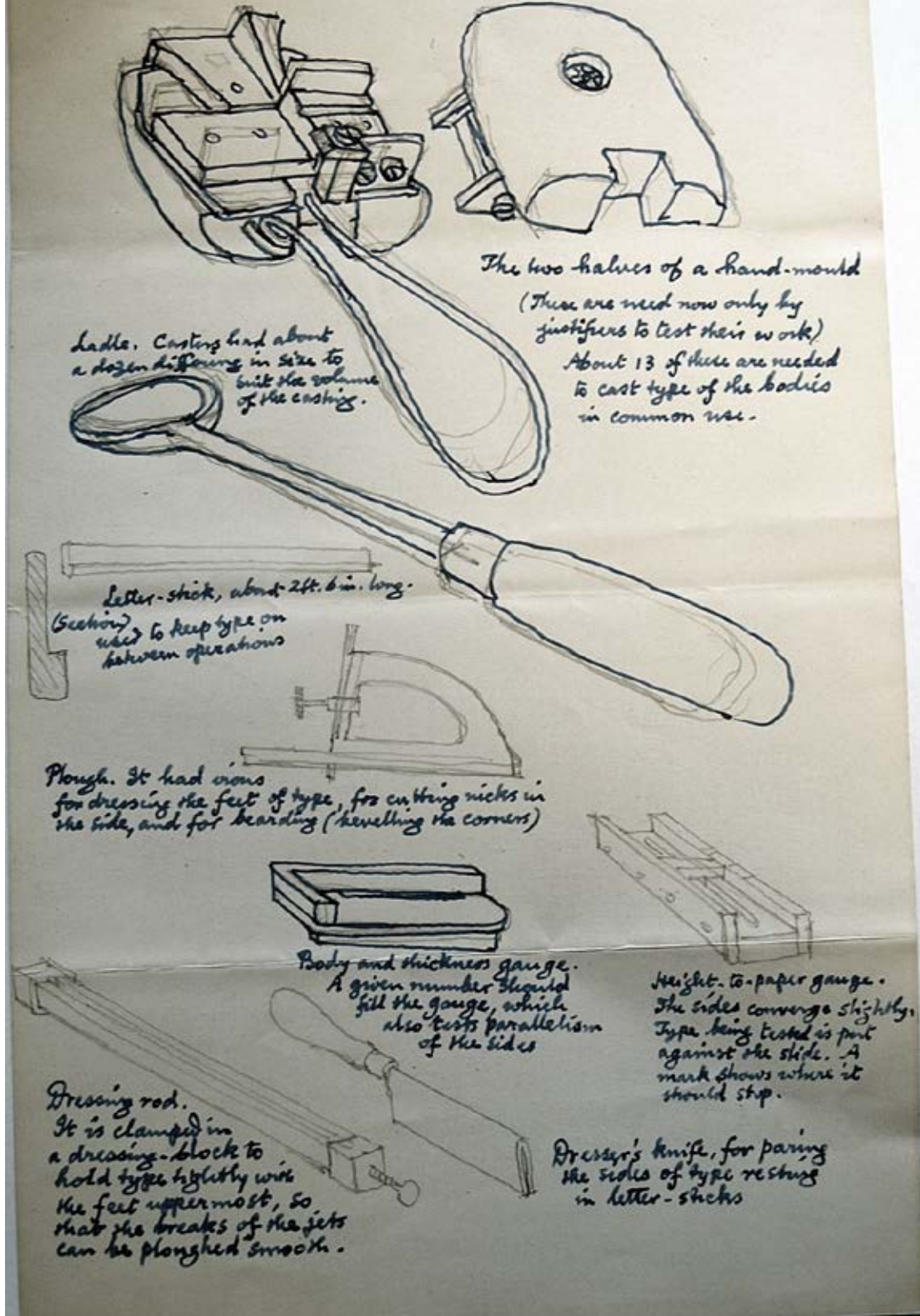

Fig. App. K.4: Illustrations and descriptions from Harry Carter's Typefounder's tools (St. Bride Library)

Appendix L: Names of the books of the Masoretic Bible

The following table lists the names of the books of the Masoretic Bible in their original Hebrew, the Latin Vulgate and in English. See http://www.paganlibrary.com/etext/latin_vulgate.php [Accessed 13 December 2013]. The order in which the books as listed follows Ginsburg, *Introduction to the Massoretico-critical edition of the Hebrew Bible*, Vol. 1, pp. 1-8. The 13 Books of the Apocrypha are not included as they are not considered to be part of the Masoretic text in the Jewish tradition. See also <http://www.mechon-mamre.org/p/pt/pt0.htm> [Accessed 13 December 2013]. The Bible in Hebrew has various names: *Torah*, *Esriv ve arba'ah sepharim* (24 books), *Tanakh* (an abbreviation of the Hebrew words *Ketuvim*, *Nevi'im* and *Torah*) and *Mikra* (a general term for the Prophets and Hagiographia. The Jewish canon is composed of the five books of the Pentateuch (the *Chumash*), the eight books of the prophets (the *Nevi'im*) and the eleven books of the Hagiographia (the *Ketuvim*). The early modern editions of the Prophets are often divided into the twelve Minor Prophets (*Prophetae Minores*) and the Greater Prophets (*Prophetae Majores*). These terms reflect the Hebrew terms 'Earlier Prophets' and 'Later Prophets' as introduced by the Masorah.

Part of the Bible	Hebrew Name	Transliteration	Title in the Vulgate	English
Pentateuch (Chumash)	בְּרֵאשִׁית	Berishit	Liber Genesis, Hebraice Beresith	Genesis
Pentateuch (Chumash)	שְׁמוֹת	Shemot	Liber Exodus, Hebraice Veelle Semoth	Exodus
Pentateuch (Chumash)	וַיִּקְרָא	Vayyikra	Liber Leviticus, Hebraice Vaicra	Leviticus
Pentateuch (Chumash)	בְּמִדְבָּר	BeMidbar	Liber Numeri, Hebraice Vaiedabber	Numbers
Pentateuch (Chumash)	דְּבָרִים	Devarim	Liber Deuteronomii, Hebraice Elle Haddebarim	Deuteronomy
Prophets/Nevi'im	יְהוֹשֻׁעַ	Yehoshua	Liber Iosue, Hebraice lehosua	Joshua
Prophets/Nevi'im	שׁוֹפְטִים	Shoftim	Liber Iudicum, Hebraice Sophetim	Judges
Prophets/Nevi'im	שְׁמוּאֵל א	Shmu'el aleph	Liber Primus Samuelis, Quem Nos Primum Regum Dicimus	1 Samuel
Prophets/Nevi'im	שְׁמוּאֵל ב	Shmu'el bet	Liber Secundus Samuelis, Quem Nos Secundum Regum Dicimus	2 Samuel
Prophets/Nevi'im	מְלָכִים א	Malakhim aleph	Liber Regum Tertius, Secundum Hebraeos Primum Malachim	1 Kings
Prophets/Nevi'im	מְלָכִים ב	Malakhim bet	Liber Regum Quartus, Secundum Hebraeos Malachim Secundus	2 Kings
Prophets/Nevi'im	יֵשַׁעְיָהוּ	Yeshayahu	Prophetia Isaiae	Isaiah
Prophets/ Nevi'im	יֵרֵמְיָהוּ	Yirmeyahu	Prophetia Jeremias	Jeremiah
Prophets/Nevi'im	יְחֵזְקֵאל	Yehezkel	Ezechielis	Ezekiel

<i>Part of the Bible</i>	<i>Hebrew Name</i>	<i>Transliteration</i>	<i>Title in the Vulgate</i>	<i>English</i>
Prophets/Nevi'im (Part of the 12 minor prophets = Sneim asar = prophetae Minore)	הוֹשֵׁעַ	Hoshea	Prophetia Osee	Hosea
Prophets/Nevi'im (Part of the 12 minor prophets = Sneim asar = prophetae Minore)	יוֹאֵל	Yo'el	Prophetia loel	Joel
Prophets/Nevi'im (Part of the 12 minor prophets = Sneim asar = prophetae Minore)	עָמוֹס	Amos	Prophetia Amos	Amos
Prophets/Nevi'im (Part of the 12 minor prophets = Sneim asar = prophetae Minore)	עֲבֻדְיָה	Ovadhiah	Prophetia Abdiae	Obadiah
Prophets/Nevi'im (Part of the 12 minor prophets = Sneim asar = prophetae Minore)	יוֹנָה	Yonah	Prophetia Ionae	Jonah
Prophets/Nevi'im (Part of the 12 minor prophets = Sneim asar = prophetae Minore)	מִיכָה	Mikhah	Prophetia Michaeae	Micah
Prophets/Nevi'im (Part of the 12 minor prophets = Sneim asar = prophetae Minore)	נַחֻם	Nachum	Prophetia Nahum	Nahum
Prophets/Nevi'im (Part of the 12 minor prophets = Sneim asar = prophetae Minore)	חֲבַקּוּק	Habakkuk	Prophetia Habacuc	Habakkuk
Prophets/Nevi'im (Part of the 12 minor prophets = Sneim asar = prophetae Minore)	צְפַנְיָה	Zefaniah	Prophetia Sophoniae	Zephaniah
Prophets/Nevi'im (Part of the 12 minor prophets = Sneim asar = prophetae Minore)	חַגִּי	Chagai	Prophetia Aggaei	Haggai
Prophets/Nevi'im (Part of the 12 minor prophets = Sneim asar = prophetae Minore)	זְכַרְיָה	Zekhariah	Prophetia Zachariae	Zechariah
Prophets/Nevi'im (Part of the 12 minor prophets = Sneim asar = prophetae Minore)	מְלָאכִי	Malakhi	Prophetia Malachiae	Malachi

<i>Part of the Bible</i>	<i>Hebrew Name</i>	<i>Transliteration</i>	<i>Title in the Vulgate</i>	<i>English</i>
Minore)				
Hagiographia (Writings)Ketuvim)	תְּהִלִּים	Tehilim	Liber Psalmorum	Psalms
Hagiographia (Writings)Ketuvim)	מִשְׁלֵי	Mishle	Liber Proverbiorum, Quem Hebraei Misle Appellant	Proverbs
Hagiographia (Writings)Ketuvim)	אִיּוֹב	Iyov	Liber Iob	Job
Hagiographia (Writings)Ketuvim)	שִׁיר הַשִּׁירִים	Shir Hashirim	Canticum Canticorum Salomonis, Quod Hebraice Dicitur Sir Hasirim	Song Of Songs
Hagiographia (Writings)Ketuvim)	רוּת	Rut	Liber Ruth	Ruth
Hagiographia (Writings)Ketuvim)	אֵיכָה	Eikhah	Threni, Idest Lamentationes Ieremiae Prophetae	Lamentations
Hagiographia (Writings)Ketuvim)	קוֹהֶלֶת	Kohelet	Ecclesiastes, Qui Ab Hebraeis Coheleth Appellatur	Ecclesiastes
Hagiographia (Writings)Ketuvim)	אֶסְתֵּר	Ester	Liber Esther	Esther
Hagiographia (Writings)Ketuvim)	דָּנִיֵּאל	Daniyel	Prophetia Danielis	Daniel
Hagiographia (Writings)Ketuvim)	עֶזְרָא	Ezra	Liber Primus Esdrae	Ezra
Hagiographia (Writings)Ketuvim)	נְחֵמְיָה	Nechemiah	Liber Nehemiae, Qui Et Esdrae Secundus Dicitur	Nehemiah
Hagiographia (Writings)Ketuvim)	דְּבָרֵי הַיָּמִים א	Debrei Hayamim aleph	Liber Primus Paralipomenon, Hebraice Dibre Haiamim	1 Chronicles
Hagiographia (Writings)Ketuvim)	דְּבָרֵי הַיָּמִים ב	Debrei Hayamim bet	Liber Secundus Paralipomenon, Hebraice Dibre Haiamim	2 Chronicles

ENDMATTER

Acknowledgements

This thesis owes its existence in the first instance to Professor Dr. Hendrik D.L. Vervliet, who suggested this topic of research, in spite of the fact that he had in fact considered undertaking the research himself together with Dr Adri Offenbergh. Professor Vervliet was a constant source of precise information and useful suggestions throughout the period when I was working on this thesis. As will be clear from the body of this work, his work has provided a model and an inspiration for the analysis of the Le Bé types. Another individual who needs to be acknowledged for his initial encouragement is Nigel Roche, the former Librarian of St Bride Printing Library in London.

My two supervisors, Professor Emerita Michelle Brown and Dr. J. F. Coakley, provided constant support, encouragement, feedback and useful ideas throughout the process of the PhD research and writing. I am especially grateful to Professor Brown for her sound grounding in a book historical approach during my MA course at the Institute of English Studies.

A major debt of thanks is also due to the Arts & Humanities Research Council (AHRC) which awarded me a full studentship which provided much needed financial support. In addition I received fellowships from the Bibliographical Society (UK) and the Bibliographical Society of America to support my research in Paris and Venice. I was also awarded a residency at the Fondazione Giorgio Cini in Venice. I am grateful to all of these organisations for their support.

I am also grateful to the libraries and repositories where I was able to undertake much of my research, in particular the British Library, University College Library Special Collections, the Leo Baeck College Library, John Rylands Library University of Manchester, the University of Cambridge Rare Books library, the Wellcome Library Rare Books library, the Warburg Institute Library, the School of Oriental and African Studies library, the Valmadonna Library Trust, the Houghton Rare Book Library of Harvard University and, last but not last least, my own university library, Senate House Library. In France, I made extensive use of the Bibliothèque nationale de France, the Bibliothèque Mazarine, the Cabinet des Poinçons of the Imprimerie Nationale, and the Archives nationales de France. In Venice I spent productive time in the Archivio di Stato, the Biblioteca Marciana, the Renato Maestro Library of the Jewish Community of Venice and the Biblioteca Nuova Manica Lunga of the Fondazione Cini. In Belgium I was able to use the archives of the Museum Plantin Moretus with its unique collections and am grateful to the staff of the Prentenkabinet for their helpful assistance. I would like to add a special note of thanks to Fred Smeijers, who was able to spare time to examine some of the Hebrew punches and matrices at the Museum Plantin Moretus using his specially adapted microscope.

My thanks to all those who assisted me with enquiries can of necessity be brief and can only hint at the assistance and pleasure I received from these exchanges.

- In the UK, I would like to thank Dr. Jeremy Schonfield, Professor Alastair Hamilton, Professor Andrew Pettegree, Dr. Geoffrey Roper, Rabbi Alex Chapper of the Ilford Federation Synagogue, Claire and David Bolton of the Alembic Press, Abingdon, Oxford, James Mosley, former librarian of St Bride Printing Library, London, Martyn Ould of the Old School Press, and Ilana Tahan, Hebraica Librarian at the British Library.
- In France I would like to acknowledge the assistance of Bertram E. Schwarzbach, Professor Annie Charon of the École des Chartes, Jacques André, Madame Nelly Gable and Monsieur Didier Barrière of the Cabinet des Poinçons, Madame Geneviève Guillemot of the BnF, Rémi Jimenes, Paul-Marie Grinevald and Christian Papat. A special note of thanks is due to francegenweb.org and the 'bénévole' Madame M-Françoise for her extraordinary transcriptions of various documents from the Archives nationales which were of enormous help to me given the difficulty in transcribing these often illegible documents.
- In Italy I received much information on Le Bé's Venetian period from Angela Nuova, Giuliano Tamani, Marco Menato, Mario Infelise, Neil Harris, and Renata Segre.
- In the Netherlands I owe my thanks to Adri K. Offenbergh, Emile Schrijver, and John A. Lane.
- In Israel I owe my thanks to Lyse Schwarzfuchs, Malachi Beit-Arié, Ruth Kalman, Dror Ben-Arié, Benjamin Arbel, and Amnon Raz-Krakotzkin.
- In the USA I owe thanks to Barbara Diefendorf, Benjamin Ravid, Bernard Dov Cooperman, Bruce Nielsen, Marvin J. Heller, Mary Kay Duggan, Scott-Martin Kosofsky, Stan Nelson, Stephen Burnett, and Theodor Dunkelgrün;
- In Germany and Switzerland I owe thanks to Dr. Christoph Reske, Rachel Heuberger, Dr. Hans-Joerg Kuenast, Philipp Messner, and Urs Leu.

I would also like to thank Professor Michelle Brown and my aunt, Mrs Pauline Baines, formerly designer and editor at Thames & Hudson, for proof reading this thesis for mistakes and inconsistencies which otherwise I would have overlooked.

I would like to thank as well my two examiners for the Viva, Professor Andrew Pettegree and Dr Jeremy Schonfield, for their sympathetic and constructive comments and suggestions.

Finally, my companion Jane Elizabeth Bickerton has been an enormous support throughout and I could never have achieved this much without her encouragement.

Abbreviations

(A) = Ashkenazic

AdS = Archivio di Stato

AN = Archives nationales de France

BL = British Library

BnF = Bibliothèque nationale de France

BSB = Bayerische Staatsbibliothek/Digitale Bibliothek

c. = circa

e-rara.ch = Swiss Electronic library/Elektronische Bibliothek Schweiz

fl. = floruit (flourished or active)

JNUL = The Jewish National and University Library

Kalman = Reference from Ruth Kalman, *The Bookcraft of Daniel Bomberg's Press in Venice in the first Half of the 16th Century* (1992)

Lt = Livres tournois

Lambeth = The Lambeth Palace Library

MC = Le Minutier central des notaires de Paris

MPM = Moretus Plantin Museum, Antwerp

NAF = Les nouvelles acquisitions françaises at the BnF

n.s. = new style calendar (See Glossary)

OUP = Oxford University Press

(R) = Rashi Script

Rés X = Réserve X (Rare Books Reserve at the BnF)

(S) = Sephardic

SM = Stanley Morison

STC = British Museum Short title Catalogue

UCL/SC = University College Library Special Collections

VD = VD16 or Verzeichnis der im deutschen Sprachbereich erschienenen Drucke des 16. Jahrhunderts

? = Uncertain attribution for punchcutter or volumes examined

Glossary of terms

Adapted from the online version of the *Jewish Encyclopedia* and other sources as indicated.

Term	Definition
Côte	Symbole servant à l'identification et au classement de documents dans une bibliothèque; document portant ce symbole. ⁹⁶⁴
Cursive	A rapid ductus, with fewer pen lifts and with devices to increase speed, such as linking of letters and perhaps loops. (Brown, <i>A Guide to Western Historical Scripts</i> , 2007).
Dagesh	The diacritical point placed in the centre of the letters of the Hebrew alphabet to indicate either their intensified (doubled) pronunciation, or, in the case of the letters כּנִדְבָּפֶת (b, g, d, k, p, t), their hard (unaspirated) pronunciation.
Didot	Didot point sizes for types cast in continental Europe equal 0.0148 inch or 0.376 mm and are slightly larger point-for-point than the Anglo-American point of 0.01383 inch or 0.351 mm. Thus a Didot fount cast on an Anglo-American body size is likely to require extra depth. (Williamson, <i>Methods of Book Design</i> , 1983).
Ductus	L'ordre et la direction des traits des lettres (Sirat, <i>Ecriture et Civilisations</i> , CNRS, 1976) The way in which a script is written, its speed, and care of execution and formation of letters. (Brown, <i>A Guide to Western Historical Scripts</i> , 2007)
Échevin	Officier élu ordinairement par les Bourgeois, pour avoir soin de la police & des affaires communes d'une ville pendant un certain temps (<i>Dictionnaire de l'Académie française</i> , 4th Edition (1762).
Exotics	A term applied to non-Latin typefaces, such as Amharic, Arabic, Armenian, Chinese, Coptic, Cyrillic, Ethiopian, Georgian, Greek, Hebrew, Hieroglyphics and Syriac.
Forme	Type matter and blocks assembled into pages and locked up in a chase ready for printing. The impression taken from it is called a signature. (Glaister, <i>Encyclopedia of the Book</i> , 1996)
Fount	A complete array of type characters designed and made up as a set. It normally includes upper and lower case, numerals, punctuation marks, accents, ligatures etc. A type family includes founts of roman, sloped roman, italic, bold, condensed, sanserif and sometimes Greek, Cyrillic etc (Glaister, <i>Encyclopedia of the Book</i> , 1996)
Get/Gittim	A Jewish bill of divorce
Glyph	Un caractère est une unite d'information utilisée pour coder du texte, alors qu'un glyphe est une forme géométrique (une collection homogène de telles formes constitue une police) utilisée pour présenter un texte. Le processus de présentation nécessite une application (par nécessairement bi-univoque) des caractères vers des glyphes. En fait cette notion correspond à celle d'oeil en typographie française. (André et Goossens, <i>Codage des Caractères et Multi-Linguisme: de L'ASCII à Unicode et ISO/IEC-106</i> , 1995)
Haftara/Hafarat	That portion of the Prophets read immediately after the reading of the Torah in the morning services on Sabbaths, feast-days, and the Ninth of Ab, and in the afternoon services on fast-days. The passage chosen usually contains an explicit reference to some event described in the section previously read from the Torah. The haftarot are definitely fixed and consist of from ten to 52 verses. They are read by the last person called upon by the prayer-leader or the rabbi to read from the Torah.
Hagadah (shel Pessach)	Ritual texts read for the eve of Passover (Pesach) Seder
Halakha	The collective body of Jewish law
Ḥamishah ḥumshe Torah	Name for printed versions of the Torah (as opposed to a Torah Scroll) literally the 'five five-sections of the Torah'.
Hanukiah	Hanukkah lamp, also called a Menorah
Hazakah, law of	This term has various meanings in the Talmud; the closest to the original meaning of the Hebrew root is that of "taking possession," which act constituted acquisition with regard to both movable and immovable property). But it is more frequently used to cover the acquisition of property by continued and undisturbed possession during a period of time prescribed by law.
Horologion	The Greek 'book of hours' containing the office for the canonical hours in the Greek Orthodox Liturgy. (<i>Shorter Oxford English Dictionary</i> , 1988)
Ḥumash	Informal name for a Ḥamishah ḥumshe Torah
Kashrut	The body of Jewish dietary laws.

⁹⁶⁴ 'cote' (<<http://www.larousse.fr/dictionnaires/francais/cote/19600>> [Accessed 6 November 2013]

Term	Definition
Kerning	Type faces in which part of the letter projects beyond the body, e.g. an italic f which is kerned on both side or the ascender of the character Lamed in Hebrew (Glaister, <i>Encyclopedia of the Book</i> , 1996)
Ketubah/Ketubot	A Jewish marriage contract, containing among other things the settlement on the wife of a certain amount payable at her husband's death or on her being divorced. This institution was established by the Rabbis in order to put a check on freedom of divorce, to obtain which no consent is required on the part of the woman .
Litterae dilatables	Extended Hebrew characters, normally the aleph, dalet, heh, lamed, mem, resh
Livre tournois (lt)	La <i>livre carolienne</i> a été définie par Charlemagne pour un poids de 491g; la <i>livre parisis</i> (489g), introduite sous Louis VI, se subdivisait en 20 sols (sous) et le sol en 12 deniers. Le denier étant la monnaie courante, la livre de 240 deniers jouait le rôle de monnaie de compte. Par la suite, son poids de métal, argent ou or, a été successivement réduit, et les pièces frappées à l'atelier de Tours (<i>livre tournois</i>) pouvaient avoir des valeurs différentes. Les pièces ont pris également le nom de <i>franc</i> à partir de 1360; franc et livre désignèrent l'unité monétaire française jusqu'à la Révolution. ⁹⁶⁵
Luah	A Jewish calendar
Mahzor or Machzor	Term applied to the compilation of prayers and piyyuṭim; originally it designated the astronomical or yearly cycle. By the Sephardim it was used for a collection which contains the prayers for the whole year, while the Ashkenazim employed it exclusively for the prayer-book containing the festival ritual.
Mashait	Carlo Bernheimer's name for semi cursive script and rabbinic styles in Hebrew. The term Rashi is the more generally accepted term.
Massorah	(From the Hebrew meaning 'tradition'). The system of critical notes on the external form of the Biblical text. The Masoretic annotations are found in separate works and in the form of notes written in the margins and at the end of codices. The first word of each Biblical book is also as a rule surrounded by notes. The latter are called the Initial Masorah; the notes on the side margins or between the columns are called the Small or Inner Massorah (Massorah Parva) and those on the lower and upper margins, the Large or Outer Masorah (Massorah Magna). The name 'Large Masorah' is applied sometimes to the lexically arranged notes at the end of the printed Bible, usually called the Final Masorah.
Matrix (Plural = matrices)	A metal die from which a single type is cast. In the fifteenth century matrices may have been made of lead, however copper came be used given that it is a more durable material.(Glaister, <i>Encyclopedia of the Book</i> , 1996)
Midrash	A term denoting 'exposition', 'exegesis', especially that of the Scriptures. In contradistinction to literal interpretation, subsequently called "peshat"), the term 'midrash' designates an exegesis which, going more deeply than the mere literal sense, attempts to penetrate into the spirit of the Scriptures, to examine the text from all sides, and thereby to derive interpretations which are not immediately obvious.
Mishnah (plural Mishnayot)	The oldest collection, apart from the Pentateuch, of Jewish legislative writings, which covers the whole range of Jewish legislation and tradition, comprising the religious and ritual as well as legal and ethical elements, not omitting historical traditions. (<i>Vallentine's Jewish Encyclopaedia</i> , 1938)
Mishneh Torah	Written by Moses Ben Maimon or the RaMBaM, usually called Maimonides (1135-1204). In this book Maimonides planned a complete legal system which should give in a brief but clear form the final decision in the case of each law, so that ..., every regulation, law, and custom of religious life might be learned without any other manual. He named the work the 'Mishneh Torah' or the 'Second Law', since it was only necessary to read first the written Torah and then this work in order to acquire the entire body of the so-called 'oral law'. The book contains all definitions of the Law together with all traditional explanations, statutes, and regulations, as well as the traditions and explanations of the Geonim and the customs which were given, introduced, or recognized from the time of Moses to the conclusion of the Talmud. It includes also the ethical ideas, the moral teachings, and the doctrinal principles which were traditional or which had been established by the sages or adopted by general consent.
Musaf	Additional offering or prayer. Besides the regular morning and afternoon sacrifices offered in the Temple, the Law provided for additional offerings to be brought on Sabbaths, New Moons, the three festivals, New-Year, and the Day of Atonement .
Nikkud/Nekudot	The vowel points in Hebrew Biblical texts
Oeil	En Typographie, l'œil d'un caractère est sa partie imprimante, le signe en relief qui reçoit l'encre à

⁹⁶⁵ 'La livre Tournois monnaie Française du 13° siècle.'[\(<http://tournois.alain.pagesperso-orange.fr/livre_tournois.htm>](http://tournois.alain.pagesperso-orange.fr/livre_tournois.htm) [Accessed 29 October 2013]]

Term	Definition
	déposer sur le support d'impression. (Dreyfus et Richaudeau, <i>La Chose Imprimée</i> , 1977) The closest English term would be 'appearing size'.
Old and new style calendars	The terms Old Style and New Style are applied to dates from two different historical periods. In 1582 Pope Gregory XIII decreed that in order to correct the calendar then used – the Julian calendar - the days 5-14 October of that year should be omitted and no further centennial year (e.g. 1700, 1800, 1900) should be a leap year, unless it was divisible by 400 (e.g. 1600, 2000). This reformed Gregorian calendar was quickly adopted in Roman Catholic countries, more slowly elsewhere. Dates in the Julian calendar are known as Old Style, while those of the Gregorian are New Style. (<i>New Hart's Rules</i> , Oxford University Press, 2005, p. 194). The Gregorian calendar was adopted in France in 1582. During the sixteenth century in France the <i>style de Pâques</i> or <i>mos gallicus</i> was also used, as well as other systems, such as the <i>style de la Circoncision</i> ; the <i>style de Venise</i> and the <i>style de l'Annonciation</i> . (See http://theleme.enc.sorbonne.fr/cours/livres_imprimes_anciens/date Accessed 26 November 2013)
Opentype	OpenType is a cross-platform font file format developed jointly by Adobe and Microsoft. The two main benefits of the OpenType format are its cross-platform compatibility (the same font file works on Macintosh and Windows computers), and its ability to support widely expanded character sets and layout features, which provide richer linguistic support and advanced typographic control.
Parashah	A section of the Pentateuch. The Sephardim apply the word to each of the fifty-four weekly lessons into which the Torah is divided in the one-year cycle, as well as to smaller sections; the Ashkenazim call the week's lesson a Sidra, giving the name 'parashah' to the smaller portions that are read on festivals or to one of the seven subsections in which the week's lesson is read on Sabbath mornings.
Pecia	A system used from the thirteenth century on, in which university-approved exemplars of texts were divided into sections and were hired out by stationers to scribes for copying (<i>pecia</i> means 'piece' in Latin). Not all books, even those for school use, were subject to the pecia system. The sections often carried an abbreviation of the word pecia (for example, pa) and a numeral, written inconspicuously in the margin. (Michelle Brown, <i>Understanding illuminated manuscripts: a guide to technical terms</i> (London: J. Paul Getty Museum in association with the British Library, 1994)
Puncta extraordinaria	Also called Ezra's points, These are lozenge-shaped dots which are found over (53 times) and under (3 times) certain letters. These dots predate the Masoretic system, and seem to be preserved but ignored by the Masoretes. They are also written in unvocalized texts. Probably the original meaning was to denote that the indicated letters are uncertain, perhaps have to be removed. (Such use of dots is known from the Qumran scrolls.). See http://www.win.tue.nl/~aeb/natlang/hebrew/hebrew_bible.html [Accessed 23 November 2013] However Emanuel Tov has argued that, despite the fact that 'masoretic texts and ancient sources sometimes differ in the details of paragraphing', 'it stands to reason that all these Masoretic phenomena were carefully transferred from an early scroll or scrolls'. (<i>Hebrew Bible, Greek Bible and Qumran: collected essays</i> , p. 200).
Rashi	Rashi (Solomon bar Isaac): French commentator on Bible and Talmud; born at Troyes in 1040; died there July 13, 1105. Rashi's commentary on the Pentateuch was first printed without the text at Reggio in 1475 (the first dated Hebrew book printed); five years later it was reprinted in square characters. Its first appearance with the text was at Bologna in 1482, the commentary being given in the margin; this was the first commentary so printed. Since that date there have been published a great many editions of the Pentateuch with Rashi's commentary only. At different periods other parts of the Old Testament appeared with his commentary: the Five Scrolls (Bologna, c. 1484); the Five Scrolls, Daniel, Ezra, and Nehemiah (Naples, 1487); Job, Psalms, Proverbs, and Daniel (Salonica, 1515); the Pentateuch, the Five Scrolls, Ezra, and Chronicles (Venice, 1517). The <i>editio princeps</i> of Rashi on the whole of the Old Testament was called "Mikra'ot Gedolot" (<i>ib.</i> 1525), in which, however, of Proverbs and the books of Job and Daniel the text alone was given. Owing to its importance, Rashi's commentary was translated into Latin by Christian scholars of the seventeenth and eighteenth centuries, some parts several times. The most complete Latin translation is that of John Frederick Breithaupt, which appeared at Gotha: on the Pentateuch, 1710; on the Prophets, the twelve Minor Prophets, Job, and Psalms, 1713; on the Earlier Prophets and the Hagiographa, 1714. The whole commentary on the Pentateuch was translated into German by L. Dukes (Prague, 1838), and parts of it were translated into Judæo-German by Judah Löb Bresch in his edition of the Pentateuch (Cremona, 1560), and likewise by Jacob b. Isaac in his "Sefer ha-Maggid" (Prague, 1576).
Renvoi, signe de	Signe conventionnel ou lettre de l'alphabet figurant simultanément en un point du texte (appel) et en tête d'une glose (renvoi), d'une addition, d'un autre passage, pour signaler que le lecteur doit se reporter de l'un à l'autre. (Bobichon, <i>Le lexicon: Mise en page et mise en texte des</i>

Term	Definition
	<i>manuscrits hébreux, grecs, latins, romans et arabes)</i>
Responsa	<i>She'elot uTeshuvot</i> (questions and answers) is the Hebrew designation for the 'responsa prudentium', which are the written decisions and rulings given by eminent rabbis, teachers, or heads of academies to questions addressed to them in writing. These responsa constitute a special class of Talmudic and rabbinical literature, which in form differs both from the commentaries and from the codifications of rabbinical Judaism, yet in content is similar to both.
Rosh HaShanah	The Jewish New Year (literally 'the head of the year').
Schriftbild	The concept of the letter as form = De Letter als vorm beschouwd (Van Krimpen, <i>Grafisch Zoekboek</i> , 1988)
Sefer	The word for Book in Hebrew
Selihah	Penitential prayers; perhaps the oldest portion of the synagogal compositions known under the term of <i>Piyuṭim</i> . The word "selihah" (from 'salaḥ' = 'he forgave') is particularly used in the Hagiographa as meaning 'forgiveness'; in the Middle Ages it was employed to designate penitential prayers and invocations for God's clemency and forgiveness
Set	The width of a type body also used to indicate the comparative width of a Monotype type design (Glaister, <i>Encyclopedia of the Book</i> , 1996)
Shulhan Arukh	A the code of rabbinical Judaism for all ritual and legal questions that obtained after the destruction of the Temple. This book was written by Joseph ben Ephraim Caro, the last great codifier of rabbinical Judaism, who was born in Spain or Portugal in 1488; died at Safed, Palestine, in 1575. Caro wrote the Shulhan Arukh for the benefit of those who did not possess the education necessary to understand his earlier work 'Bet Yosef'. The arrangement of this work is the same as that adopted by Jacob ben Asher in his 'Arba'ah Ṭurim', but more concise; nor are any authorities given.
Siddur	An Ashkenazic term for the collection, in one book, of the year's prayers for week-days, Sabbaths, holy days, and fast-days is generally known as the 'Seder Tefilot', or simply the 'Siddur'.
Smoke proof	(<i>Fumé</i> in French) An impression of a punch made with the soot of a flame on paper or a transparent film (Paput, <i>La lettre: La Gravure du Poinçon Typographique</i> , 1998)
Strike	(Une <i>Frappe</i> in French) The state of the matrix before it is justified. It was normal practice in the sixteenth century to sell rough strikes to printers, such as Plantin, who then had them justified. (Carter, <i>A view of Early Typography</i> , 2002)
Ta'amin	Cantillation marks (from the word 'ta'am' meaning taste) used in the Hebrew Bible to mark the various degrees of logical, or sense, pausation and each symbol is equal to several musical notes This method of pauses led to a the development of a half-singing style which is called Cantillation; and is used in the reading of the Bible in Jewish synagogues.
Talmud	Name of two works which have been preserved as the product of the Palestinian and Babylonian schools during the amoraic period, which extended from the third to the fifth century C.E. One of these compilations is entitled 'Talmud Yerushalmi' (Jerusalem Talmud) and the other 'Talmud Babli' (Babylonian Talmud). Used alone, the word 'Talmud' generally denotes 'Talmud Babli', but it frequently serves as a generic designation for an entire body of literature, since the Talmud marks the culmination of the writings of Jewish tradition, of which it is, from a historical point of view, the most important production.
Tanach	Tanakh [תנ"ך] (also Tanach or Tenach) is an acronym that identifies the Hebrew Bible. The acronym is based on the initial Hebrew letters of each of the text's three parts: Torah [תורה] meaning one or all of: "The Law"; "Teaching"; "Instruction". Also called the Chumash [חומש] meaning: "The five"; "The five books of Moses". It is the "Pentateuch". Nevi'im [נביאים] meaning: "Prophets" Ketuvim [כתובים] meaning "Writings" or "Hagiographa". The Tanakh is also called [מקרא], Mikra or Miqra. ⁹⁶⁶
Tang	The excess casting or shank on the end of the typeface character which is broken off at the finishing stage to make the character the precise type height required for printing
Tefilah/tefilot	The word for Prayer in Hebrew
Tehilim	Books of Psalms
Tetragrammaton	The quadriliteral name of God, יהוה
Text (Also body) types	The type used for the main body of a work, excluding displayed matter. In French <i>caractères de labeur</i> or in German <i>Brotschrift</i> , (Glaister, <i>Encyclopedia of the Book</i> , 1996 and Van Krimpen, <i>Grafisch Zakboek</i> , 1988)
Titling alphabet	A fount of capital letters set without shoulders as the head of chapters so that the strokes of the character extend to the limit of the body, there being no beard. Does not include lower case letters, but does include ranging numerals and punctuation. (Glaister, <i>Encyclopedia of the Book</i> , 1996)

⁹⁶⁶ 'Tanakh' (<http://www.bibliahebraica.com/the_texts/tanakh.htm> [Accessed 01 November 2013])

<i>Term</i>	<i>Definition</i>
Torah	Name applied to the five books of Moses, Genesis, Exodus, Leviticus, Numbers, and Deuteronomy
Tosafot	Critical and explanatory glosses on the Talmud, printed, in almost all editions, on the outer margin and opposite Rashi's notes. The authors of the Tosafot are known as Tosafists ('ba'ale ha-tosafot').
xylography	Xylography means wood engraving, and is the oldest known relief printmaking technique. Using a block of wood in somewhat the same manner as a rubber stamp, a xylographer cuts or carves wood away from those parts of the design that will <i>not</i> be inked. The printing of block books by xylography also means "not typography", when used to print texts or illustrations from woodblocks. http://arthistory.about.com/od/glossary/g/x_xylography.htm [Accessed 11 April 2014]

Permissions for use of Images

The following permissions for use of images has been received. Due to limitations of space, only a shortened credit has been used in the captions. The full permissions and dated granted are given below.

Archives nationales de France: Document conservé aux Archives Nationales, Paris. Cliché Atelier photographique des Archives Nationales. Email 16 October 2013

Bibliothèque nationale de France: Vous avez donc l'autorisation de notre part de reproduire ces images dans votre thèse. Email from Philippe Bretagnon Pôle redevance 28 Dec 2011

Bodleian Library: We are happy to give you permission to reproduce the title page of Opp. add. 12mo. 107 in your dissertation, as well as waive the fees. Email dated 16 October 2013

British Library: The Library grants permission to use the image in your Phd thesis, the fees have been waived, please credit the Library accordingly. © British Library Board (followed by the shelfmark). Email 12 July October 2011

Ets Haim Bibliotheek/Library Ets Haim, Amsterdam: We have received your request to publish an item from the Ets Haim Collection. We are pleased to grant you permission to publish the following items from the Collection for the use described in your request: Ets Haim Collection, EH 47 A 11, fol. Xxx Email from Heide Warnck 10/04/2014

The Jewish National and University Library: The Jewish National & University Library

The John Rylands Library in Manchester: Copyright of the University of Manchester. Email 24 September 2013

Lambeth Palace Library: By Permission of the Trustees of Lambeth Palace Library. Email 27 September 2013

Leo Baeck College: By permission of Dr Annette Boeckler, Librarian. Leo Baeck College Library, London. Email 1 October 2013

Plantin Moretus Museum: You have permission to use the images in your publication. Because of the scholarly nature of the publication, you are exempted from the reproduction fee. We ask you to mention the museum as follows: Museum Plantin-Moretus/Prentenkabinet, Antwerp – UNESCO, World Heritage' Email from Nico De Brabander (reproductions) 29 november 2013

St John's College, Cambridge: By permission of the Master and Fellows of St John's College, Cambridge. Email 11 May 2011

University of Amsterdam Special Collections: For the images from the Athias Cabinet: Collection Tetterode, Special Collections, University of Amsterdam. For all

other: Bibliotheca Rosenthaliana, Special Collections, University of Amsterdam.
Email from Rachel Boertjens, Curator Bibliotheca Rosenthaliana 7 October 2013

University of Frankfurt Library: We will give permission to reproduce the image 'Lettergieterij van Johannes Enschede te Haarlem' (in: Proef van letteren: welke gegooten worden in de nieuwe Haerlemsche lettergieterij van J. Enschedé. 1768. HM 6: Em 9) Email from Angelika Eichinger 22 October 2013

University College Library Special Collections: The Director of UCL Library Services is very happy for you to use our collections. Please be sure to acknowledge UCL Library Services, Special Collections. Email 16 October 2013

Württembergische Landesbibliothek Stuttgart: I give you the permission to reproduce this image for your thesis. Email from Dr. theol. Christian Herrmann 16 October 2013

In addition to the British Library and UCL Special Collections, Hebrew editions were examined in the BnF in Paris, and the Bibliothèque Mazarine in Paris, as well as on such online digital databases as the Jewish National University Library Digitised Book Repository, Google Books, Archive.org, VD16 and e-rara.ch.

Index to technical matters discussed in this thesis

Given the structure chosen for this thesis, the descriptions of technical matters relating to production of punches, matrices and text composition have been incorporated into the main discussion at relevant points throughout the text. The following index provides an alphabetical listing of these topics and where they can be found within the text.

<i>Topic</i>	<i>Chapter</i>	<i>Start page</i>
Alphabet, Hebrew	Chapter 1	51
Dagesh points, Insertion of	Chapter 3 Chapter 4	187, 188, 195, 247, 247,
Engraver, profession of	Chapter 2	67
Hebrew composition, order of	Chapter 3	199
Hebrew composition, possible combinations	Chapter 4 Appendix J	270, 592
Music punches	Chapter 3	158
Portmanteau Sorts	Chapter 3	173
Punchcutting	Chapter 1	31
Pump drill, use of	Chapter 3	194
Stepped punches	Chapter 2	106
Swash caps, in Hebrew	Chapter 4	224
Type cases, Hebrew	Chapter 3	174
Type character parts, Hebrew	Chapter 1	40

Primary sources

Note: Wherever possible, the original title in Hebrew characters has been included, such as from the collections of the British Library. Otherwise the transcription of the Hebrew follows the style used by the library where the relevant volume was examined. See Appendix I for a more complete listing of the Estienne Hebrew editions. Please note that not everything edition listed in this bibliography of primary sources is mentioned in the thesis text, as the Le Bé typefaces were not found in all editions examined.

Editions without stated author:

Alfa beta de-Ven Sira: meshalim... (Venice 1544)

Alphabetum Graecum/Alphabetum Hebraicum (Paris: Robert Estienne, 1528)

Alphabetum Hebraicum (Paris: Robert Estienne, 1539)

Alphabetum Hebraicum (Parisiis: Ex officina Roberti Stephani, typografi Regii, 1543/4)

Alphabetu[m] Hebraicum (Lutetiae: Ex Officina Roberti Stephani, 1550)

Alphabetum Hebraicum (Paris: Chrétien Wechel, 1533 and 1553)

Alphabetum Hebraicum (Paris: Robert Estienne, 1563)

Alphabetum Hebraicum (Antverpiæ: Ex officina Christophori Plantini, 1569)

Alphabetum Hebraicum decerptum è quadrilingui Grāmatica ... (Paris: Chrétien Wechel, 1543)

Alphabetum Hebraicum. De pronuntiatione literarum Heb., ... decem ... Domini praecepta, Hebraicè & Latinè, etc. (Alphabetum Graecum. Precatio Dominica. Salutatio Angeli ... Græcè & Latinè Omnia (Parisiis: Ex officina R. Stephani, 1539)

ארבעה ועשרים Arba'ah ve-esrim [Pentateuch] (Pesaro: Gershom Soncino, 1511-17)

ארבעה ועשרים: עם באור כל מלה קשה Arba'ah ve-esrim [Pentateuch] (Venice: Giovanni di Gara, 1570)

Bible OT Minor Prophets (Joel/Amos/Abdias/Jonas) (Geneva: Robert Estienne, 1556)

Bible. O.T. Hebrew. ... Hamishah humshe Torah (Antwerp: al yede Krystoforo Planten, 1573-74)

Bible. O.T. Samuel. Hebrew & Latin. . Samuelis libri duo: Ebraice & Latine ad usum academiarum (Lugduni Batavorum = Leiden: Prostant apud Iohannem Maire, 1621)

La Bible qui est toute la sainte escriture [La Bible d'Olivétan] (Neuchâtel: Pierre de Vingle, 1535)

Biblia Hebraica (Paris: Antoine Claude Briasson and Laurence Durand, 1753)

Biblia. (Hebraica, Chaldaea, Graecaque et Latina nomina virorum, mulierum, populorū... quæ in Biblijs ... sparsa sunt ... hoc volumine comprehenduntur, cum interpretatione latina, (Parisiis: Ex officina R. Stephani:, 1528 and 1532)

Biblia/Sefer Habucuc (Paris: Charles Estienne, 1559)

Biblia: 1. Hebraica: 2. Samaritana: 3. Chaldaica: 4. Graeca: 5. Syriaca: 6. Latina: 7. Arabica: Quibus textus originales totius Scripturae Sacrae ... exhibentur (Lutetiæ Parisiorum: Antoine Vitre, 1645)

Biblia Sacra (Paris: Ex officina Simonis Colinaei, 1541)

Biblia Sacra Hebraea (Leiden: Georg Nissel, 1613)

Biblia Sacra/Regia (Antwerp: Christophe Plantin, 1569-73)

Biblia Sacra juxta vulgatem quam sicut editionem ... [Secunda Editio] (Paris: Guillaume Des Bois/Charlotte Guillard, 1552)

Birkat HaMazon (Basle: Waldkirch, 1598/99)

Duodecim Prophaetae (Paris: Robert Estienne, 1539)

Epreuves des Caractères du Fond des Sanlecques (Paris: Auguste-Martin Lottin, 1757)

Figures des Histoires Thomade la Sainte Bible (Paris: Guillaume Le Bé, 1666)

Halakhot gedolot (Vinitsiah be-vet Marko Antoniyo Yushtiniyan, 1548)

Hamishah humshe Torah Bible (O.T. Hebrew) (Venetsiyah nidfas revit al yede Daniel Bombergi, 1522-33)

Hamishah humshe Torah ve-Hamesh megilot ve-haftarot (Bible. O.T. Pentateuch. Hebrew) (Venetsiah: Zoan Digara, 1597)

Hamishah humshe Torah (Constantinople: David and Samuel ibn Nachmias, 1505)

- תורה המשה הומשי תורה *Ḥamishah ḥumshe Torah*. [Nidpas sheni] (Venice: Daniel Bomberg, 1521)
- תורה המשה הומשי תורה *Ḥamishah ḥumshe Torah: ve-ḥamesh megilot*. Venice; Giovanni di Gara, 1525-28 and 1597)
- תורה המשה הומשי תורה *Ḥamishah ḥumshe Torah*. [Nidpas shelishit] (Venice: Bomberg, 1525-28)
- תורה המשה הומשי תורה *Ḥamishah ḥumshe Torah*. [Nidpas reviit] (Venice: Daniel Bomberg, 1533)
- תורה המשה הומשי תורה *Ḥamishah ḥumshe Torah*. [Nidpas hamishit] (Venice: Daniel Bomberg, 1544-45)
- תורה המשה הומשי תורה *Ḥamishah ḥumshe Torah* (Paris: Robert Estienne, 1539-1544)
- תורה המשה הומשי תורה *Ḥamishah ḥumshe Torah* (Paris: Robert Estienne, 1544-1546)
- תורה המשה הומשי תורה: עם חמש מגלות והפטרות מכל *Ḥamishah Ḥumshe Torah: 'im Ḥamesh megilot va-Haftarot mi-kol ha-shanah* (Ferrara: Abraham Usque, 1554)
- תורה המשה הומשי תורה *Ḥamishah ḥumshe Torah* (Geneva: Robert Estienne, 1555-56)
- תורה המשה הומשי תורה *Ḥamishah ḥumshe Torah* (Antwerp: Christophe Plantin, 1566, 1567, 1573 and 1580)
- תורה המשה הומשי תורה וכו *Ḥamishah ḥumshe Torah ..* (Biblia Hebraica) (Antwerp: Plantin, 1582)
- תורה המשה הומשי תורה, נביאים ראשונים, ארבעה נביאים אחרונים, ספר כתובים *Ḥamishah ḥumshe Torah, Nevi'im rishonim, Arba 'ah Nevi'im aḥaronim, Sefer Ketuvim* (Venice Daniel Bomberg, 1517)
- תורה המשה הומשי תורה ... עם פירוש ... רש"י ... תרגום אנקלוס וכו *Ḥamishah ḥumshe Torah* (Venice: Giovanni di Gara and Alvise Bragadin, 1590-91)
- תורה המשה הומשי תורה וכו *Ḥamishah ḥumshe Torah ...* (Hanau: Philip Ludwig, 1610)
- Hebraica Biblia Latina planeque nova Sebast. Munsteri tralatione* (Basileae: Ex officina Bebeliana, impendiis Michaëlis Isingrinii et Henrici Petri, 1534)
- Helek rishon meha-Mahazor kefi minhag k.,k. Roma: im perush Kimha de-avshuna [a. y. Yohanan ben Yosef Ish Trivish] u-masekhet Avot im perush ... ha-Rambam ve-im perush ...* (Siddur (Roman rite). 1540. .) (Bolonya: Ovadyah Sforno, 1541)
- Ὠρολόγιον/Horologion* (Venice: Christophano Zanetti, 1546)
- Hoshea: im targum u-ferush Rashi ve-Ibn Ezra ve-David Kimhi ... u-masorah ... / Hosee cu Thargum, id est Chaldaica paraphrasi Ionathan, & comentariis R. Selomo Iarhi, R. Abraham Aben Ezra, & R. D. Kimhi: variis lectionibus ex multorum exemplarium diligenti collatione in margine ascriptis* (Paris: Al yede Robertos Stefanos, 1556)
- תרגום עם תרגום *Ḥumash 'im Targu[m]* (Venice: Daniel Bomberg, 1543)
- תרגום הרבותירושלם: ... מגיד מקצת הצרות אשר עברו הלפו על ירושלם *Ḥurvot Yerushalayim: ... magid mi-ḳetsat ha-tsarot asher 'avru ḥalfu 'al Yerushalem* (Venice: Giovanni Vendramin, 1636)
- Index Librorum in hac officina impressorum* (Paris: Charles Estienne, 1552)
- Isouae imperatoris historia illustrate explicata ab Andrea Masio* (Antwerp, Christophe Plantin, 1574)
- Isagoge Gil. Genebrardi* (Paris: Apud Aegidium Gorbinum, 1587)
- איוב ודניאל *Iyov ve-Dani'el* (Venice: Daniel Bomberg, 1538)
- קהלת *Ḳohelet = L'Ecclesiaste di Salomone: nuouamente dal testo hebreo tradotto, et secondo il uero senso nel uolgar idioma dichiarato / dall' eccellente phisico David de' Pomi* (Venice Ziletti, 1571)
- Kol-Bo. Sefer Kol Bo: ... shem sefer zeh Kol bo mevoar al ki shemo be-kirbo. Ve-hu sefer kelilat yofi. Lo yehsar bo shum shemets va-rofi. Bo yitbaer kol mitsvah ve-din Torah ve-hukah* (Venice: Zorzi di Kavali, 1567)
- Liber Psalmorum Davidis* (Geneva: Robert I Estienne, 1556-57)
- Linguarum Orientalium, Hebraicæ, Rabinicæ, Samaritanæ, Syriacæ, Græcæ, Arabicæ, Turcicæ, Armenicæ, alphabeta* (Parisiis: Apud Antonium Vitray, 1636)
- Literæ Illustriss. Principis Ludovici Borbonii ... ad Carolum IX. Galliae regem, quibus ejus fidem implorat ... Ejusdem Testificatio causarum quæ eum arma sumere coegerunt ... Literæ Reginae Navarræ ad regem Galliae ... quibus causas exponit cur sese principi Cōdæo cōjūxerit ... Narratio cædis in Lud. Borbonium ... perpetratæ ... Varia variis linguis scripta in eundem epitaphia.* (Geneva, Henri Estienne, 1569)
- לוח *Luah* [A Jewish calendar for the year of the creation, [1597-98] (Venice: Govanni di Gara, 1597/8)
- לוח רומי *Maḥzor mi-kol ha-shanah ke-minhag yitbarakh shem ha-bore ḳ.k. Romi* (Italy: 1500?)
- לוח רומי *Maḥzor mi-kol ha-shanah* (Pesaro:?, 1520?)

- Machzor mi-kol ha-shanah: ke-minhag kehilot pihem, polin u-merheren* (Machzor Ashkenazi rite) (Vinitiah: Bi-defus Zorzi di Kavali, 1568)
- Machzor (Ashkenazi rite). ha-Mahazor ha-gadol mi-kol ha-shanah ke-minhag ha-kehilot ha-kedoshot ve-ha-tehorot kehilot Ashkenazim* (Saloniki: Shelomoh ve-Yosef Yaavets, 1560)
- Machzor: ke-minhag k.k. Ashkenazim* (Venice: Giovanni di Gara and Alvise Bragadin, 1599/1600)
- Maḥzor shalem mi-kol ha-shanah: nidpas shelishit ke-fi minhag ha-lo'azim / higiho Rabi Avraham mi-Ḳaṣṭil* (Rimini, Soncino?, 1521)
- Maḥzor mi-khol ha-shanah : ... ke-fi seder u-minhag de-k.ḳ Vrankvurt u-she'ar kehilot ...* (Hanau: Typographia Orientalis, 1625)
- Masekhet Berakhot: 'im perush Rashi ve-tosafot* (Venice: Giustiniani, 1546-1550)
- Machzor: helek sheni ke-minhag k.k. Romah [Rosh ha-shanah, Yom kipur, Sukot, Ta'aniyot]* (Venice: Giovanni di Gara, 1587)
- Maḥzor mi-kol ha-shanah* (Pesaro, 1520)
- Maḥzor mi-khol ha-shanah: ... ke-minhag k.k. Romah* (Mantua, 1557)
- Maḥzor mi-kol ha-shanah ke-minhag yitbarakh shem habore k.k. Romi*. 2nd ed., 1500?)
- Maḥzor me-Rosh ha-Shanah ve-Yom ha-Kipurim 'im perush Mosheh Ḳordoero ve-'im teshuvot le-khol 'averah me-yisud* (Constantinople, 1576)
- Maḥzor shel Rosh ha-Shanah ve-Yom ha-kipurim le-minhag kehilot asher hayu mi-qedem be-malkhut Aragon* (Salonica: Gerson of Soncino, 1529)
- Masekhet berakhot [-Nidah] : 'im perush Rashi ve-tosafot u-fiske tosafot ve-Rabenu Asher ve-ha-mishnayot 'im perush ha-Rambam ... = Massecheth Berachoth : opus, in quo de benedictionibus, de gratiis Deo agendis, de orationibus, & divinis laudibus agitur recognitum a Marco Marino et ab omnibus iis, quae contra religionem Christianam sunt, juxta mentem Concilii Tridentini expurgatum, adeo, ut non modo sitra impietatem, verum etiam cum fructu legi possit* (Berolini; Francofurti ad Oderam, 1715-1739)
- Me'ah berakhot: ke-minhag ha-Sefaradim 'im piyuṭim me-ḥadash nosafim* (Ferrara: Usque, 1554)
- Midrash Rabbot* (Venice: Giustiniani, 1545)
- Mishneh Torah* (Venice: Bragadin, 1550)
- Mishneh Torah* (Venice: Giustiniani, 1550/51)
- Mishnayot: mi-seder Mo'ed im perush ha Rav Ha Muvhak HaGa'on ... 'Ovadyah mi-Bartenorah* (Venice: Carlo Qurini/Meir Parenio, 1548)
- Mishnayot mi-seder Ṭohorot / 'im perush ... 'Ovadyah mi-Bartenorah* (Venice: Carlo Qurini/Meir Parenio, 1548/49)
- Mishnayot: mi-seder Zeraim [-Ṭohorot] im perush ha-Rambam: [ve-im masekhtot ḳeṭanot] / [perush Shimshon ben Avraham al...Zeraim Ṭohorot]* (Venice, 1546)
- Otiot shel Rabi Akiba* (Venice: Giustiniani, 1546)
- Παρακλητική/Paracletius* (Liturgies.Greek Rite. Oktoechos) (Venice: Christophe Zanetti, 1559)
- Psalterium/Sefer Tehilim* (Paris: Robert Estienne, 1545)
- Psalmus Primus cum Commentarijs* (Paris: Guillaume II Le Bé, 1612)
- Seder Hagadah shel Pesah: Seder hagadah shel Pesah: blashon ha-kodesh u-blashon Ashkenazim, 'im kamah tsurot ... ve-gam ... perush Tseli esh. bi-leshon ha-ḳodesh uvi-leshon Ashkenazim, 'im kamah tsurot ... ve-gam ... perush Tseli esh.* (Venice: Isaac he-levi for A. Bragadin, 1716)
- Seder ma'amadot: le-halel ule-hodot be-khol yom ve-yom* (Venice, 1545)
- Seder ma'amadot: ... mugah u-meduyak* (Ferrara, Usque, 1554)

Seder tefilot mi-kol ha-shanah מכל השנה (Venice: Giustiniani, 1546)
Seder Olam rabbah (Seder olam Raba seder olam zuṭa: megilat Taanit sefer ha-Ḳabalah leha-Rabad) (Venice: Giustiniani, 1545)
השנה *Seder tefilot mi-kol ha-shanah* (Venice: 1545)
הקראים *Seder ha-tefilot: ke-minhag kehal ha-ḳara'im* (Venice, 1528)
השנה *Seder tefilot mi-kol ha-shanah* (Venice, 1545)
התחנות *Seder tefilot mi-kol ha-shanah: ke-minhag k.k. bene Sefarad* (Venice, 1546)
היהו *Sefer Tana Divrei Eliahu* (Venice: Zanetti, 1598)
היהו *Shirei Musar HaSekhel* (Mantua: Giacomo Rufinelli, 1560)
היהו *Sefer Mikrae Kodesh* (Venice Bragadin and Parenzo, 1586)
היהו *Sefer Mishle/Shir ha-shirim - Kohelet* [Nidpas shelishit] (Venice: Bomberg, 1538)
היהו *Sefer Kad Ha-Kemach* (Venice: Giustiniani, 1545)
היהו *Sefer Ketuvim im ha-Targum* (Bible. O.T. Hagiographa. Hebrew) (Vinitsyah al yedey Daniel Bombirgi mi-Filandriyah, 1517/1518)
היהו *Seder ma'amadot; le-halel ule-hodot be-khol yom ye-yom* (Venice: 1545)
היהו *Sefer Ruah hen im peirusho* (Cremona: Vincenzo Conti, 1566)
היהו *Sefer Shulhan Arba'ah* (Venice: Giustiniani, 1545)
היהו *Sefer tana devey Eliyahu: ve-hem devarim ati.kin u-metukim* (Aggadat Bereshit) (Vynytsyah Daniel Zaniti, 1598)
היהו *Sefer Tanhuma* (Mantua, 1563)
היהו *Sefer Tehilim (Psalmi)* (Antwerp: C. Plantin, 1581)
היהו *Sefer Tehilim / im perush ... rabenu David Kimhi* (Bible. O.T. Psalms. Hebrew) (Krimonah: Vitsentso Konti, 1561)
היהו *Sefer Tehilim/Psautier Bomberg* (Venice: Daniel Bomberg, 1518)
היהו *Sefer Tehilim* (Venice: Daniel Bomberg, 1544)
היהו *Sefer Tehilim [Psalms]* (Leiden: Raphelengius, 1615)
היהו *Selihot: ke-minhag Ashkenaz* (Barco G. Soncino, 1496)
היהו *Sha'ar bet H. he-hadash: ... Humash im Targum va-Hamesh megilot ve-Haftarot* (Venice: Giustiniani, 1546)
היהו *Siddur* (Basle: Waldkirch, c. 1598)
היהו *Siddur ha-tefilot: ke-minhag Ashkenaz...* (Mantua: 1557)
היהו *Siddur shel minhag Halap* (Venice: Daniel Bomberg, 1527)
היהו *Siddur ke-minhag k.k. bene Romi* (Venice: Daniel Bomberg, 1525/26)
היהו *Talmud. Eruvin. Bomberg. Eruvin*: [Kerekh 4 min Talmud Bavli]. (Vinitsiah: Daniyel Bombirgi, 1520)
היהו *Siddur: ke-minhag ha-lo'azim* (Venice, 1549)
היהו *Siddur ke-minhag k.k. bene Romi* (Venice: Daniel Bomberg, 1525)
היהו *Siddur [Roman rite]* (Bologna: Ovadia ben Jacob Sforno, 1540/41)
היהו *Sha'ar bet H. he-hadash: ... Humash im Targum va-Hamesh megilot ve-Haftarot* (Venice: M. A. Giustiniani, 1546)
היהו *Tefilot mi-kol ha-shanah: im kamah perushim u-Firke avot im ha-perush me-Radaḳ* (Trino: Nidpas 'al yede Nitán'el b.R. Perets Halfan, 1525)
היהו *Tehilim* [Nidpas shenit] (Venice: Daniel Bomberg, 1521-1522)
היהו *Temunot teḥinot tefilot Sefarad* (Venice: 1581)
היהו *Temunot teḥinot tefilot Sefarad* (Venice: Daniel Zanetti, 1598)
היהו *Temunot teḥinot tefilot Sefarad: u-fiyuṭ u-fizmon be-tokho* (Bomberg and Adelkind: Venice, 1524)

Tefilah mi-khol ha-shanah (Venice, 1529?)
 Tefilot shel Yamim nora'im ve-shel Sukot (Prague: 1533-34)
 Torah with Persian and Arabic Targum (Constantinople: Eliezer ben Gershon Soncino, 1546)
 Zeh ha-sha'ar le-H. : ... tefilah, me-reshit ve-'ad aḥarit ha-shanah ke-fi minhag k.k. Romi (Bologna: Thalmay, 1537)
 Zot ha-Torah asher katav Mosheh li-vene Yisrael: ... od Hamishah megilot (Venice: Daniel Bomberg, 1544)

Editions with stated author:

Aaron, ha-Levi of Barcelona, ספר החינוך *Sefer ha-ḥinukh* (Venice: Daniel Bomberg, 1523)
 Aaron, of Pesaro, מראה מקום מכל הפסוקים מחמשה חומשי תורה וחמש מגילות הנמצאים בשיתא *Zeh Sefer Toledet Aharon: mar'eh maḳom mi-kol ha-pesukim mi-Ḥamishah Ḥumshe Torah ve-Ḥamesh Megilot ha-nimtsa'im be-shita sidre ha-masekhta* (Venice: Bragadin, 1591)
 Aboah, R. Isaac the elder, ספר מנורת המאור / חברו יצחק אבוהב ספרדי *Sefer menorat ha-ma'or / ḥibro Yitshaq Abohab Sefardi* (Zuan di Fara: Venice, 1544)
 ———, ספר זבח פסח: המאמר הזה הוא פירוש בהגדות הפסח ... / חברו דון יצחק אברבנאל, *Sefer Zevah Pesah: ha-ma'mar ha-zeh hu perush be-hagdot ha-Pesah* (Venice: Giustiniani, 1545)
 Abravanel, Isaac, Toviyah Foah, and Azariah ben Moses dei Rossi, פירוש למשנה תורת אל *Mirkevet ha-mishneh: perush le-mishneh torat el*(Sabbionetta: Tuvia Foa, 1551)
 ———, ראש אמנה: כולל שרשי וראשי האמונות / חברו יצחק אברבנאל, *Sefer Rosh Emunah* (Venice: Giustiniani, 1545?)
 ———, ראש אמנה *Sefer Rosh Emunah* (Constantinople: David and Samuel Nachmias, 1506)
 Abudarham, David ben Joseph, אהל לפרש תפלות כל השנה אמר דוד ב"ר יוסף ס"ט ב"ר דוד נ"ע בן אבודרהם *Abudarham be-'ezrat elohe kedem shokhen me'onah : aḥel le-faresh tefilot kol ha-shanah ... / amar David be-R. Yosef Abudarham ...* (Venitsiah: Marko Antonio Yostinian, 1546)
 Abudarham, David ben Joseph, אבודרהם: ... לפרש תפלות כל השנה ... / דוד ב"ר יוסף ... בן אבודרהם *Abudarham* (Venice: Giovanni di Cavalli, 1566)
 Adarbi, Itzhak ben Shmuel, *Sefer She'eolot uTeshuvot* (Venice: Di Gara, 1586/7)
 Adonijah, Jacob ben Hayyim ben Isaac ibn, and Daniel Bomberg, מוגה כהלכתו *Ḥumash 'im Targu[m]: mugah ke-hilkhato* (Venice: Daniel Bomberg, 1527)
 Adret, Solomon ben Abraham, *She'elot u-teshuvot*. (Venice: M. A. Giustiniani, 1546)
 ———, *She'elot u-teshuvot / she-ḥiber Shelomoh ben Adret* (Hanau: Hans Jakob Henne, 1610)
 Aharon of Pesaro, ספר תולדת אהרן *Sefer Toledot Aharon* (Freiburg im Breisgau: Zifroni, 1584)
 Albelda, Moses ben Jacob, *Sefer Shaare dimah* (Vinitsiah: Zon di-Garah (for Alvise Bragadin), 1586)
 Albo, Joseph, ספר העקרים / חברו יוסף אלבו ספרדי *Sefer iḳarim*. (Venice: Nidpas al yede Misir Zoane di Fari, 1544)
 Aldabi, Meir ben Isaac, *Sefer Shevile emunah* (Riva di Trento: Jacob Marcaria and Joseph Ottolenghi under the aegis of Cardinal Cristoforo Madruzzo, 1559)
 Alexander Suslin, ha-Kohen, of Frankfurt, *Sefer ha-agudah: ... ve-hu kitsur mi-hidushe dinim / ḥibro Aleksandri ha-Kohen Zuislin; ve-hugah ha-hetek al yede Yosef Kats* (Cracow: Yitshak ben Aharon mi-Pristits, 1571)
 Alfandari, Aaron ben Moses, אהרן בכמה"ר משה אלפנדארי *Sefer Mirkevet ha-mishneh: ... al Sefer ha-Yad* (Izmir, 1755)
 Alfasi, Isaac ben Jacob, ספר רב אלפס *Sefer Rav Alfasi: 'al kol ha-devarim asher hayu 'al ... sifre Alfasi ha-rishonim ve-nityasef ... tsiyunim 'al pirte piske ha-Rav ... ve-'od nityasef hidushe Ri'az she-hu Rabenu Yesha'yah aḥaron ... ve-gam hagahot nityasfu 'al ha-Mordekhai ve-'al kulam nidpas sefer Ma'or ha-gadol u-Ma'or ha-ḳaṭan me-et Rabenu Zerahyah ha-Levi ... ve-gam sefer Milḥamot H. asher ḥiber ha-Ramban ..* (Venice: Bragadin, 1552)
 Alfual, Isaac ben Hayyim, *Sefer Nofet tsufim* (Kostandina [Constantinople], 1579)

- Alkabez, Solomon ben Moses ha-Levi, and Moses ben Solomon Alkabetz, פירוש על מגילת רות, *Shoresh Yishai: perush al Megilat Ruth* (Constantinople: Usque, 1561)
- Almalikh, Avraham ben Yehudah, *Sefer Likute shikheah u-feah* (Ferrara: Avraham Usque, 1556)
- Almoli, Solomon ben Jacob, *Pitron halomot / leha-hakham Shelomoh Almoli* (Cracow: 1580?)
- Almosnino, Moses ben Baruch, *Sefer tefilah le-Mosheh* (Saloniki: Joseph Jabez, 1563?)
- Alshekh, Moses, and Giovanni Di Gara, שושנת העמקים: ... והוא באור מגלת שיר השירים / להרב משה אלשיך, *Shoshanat ha-'amakim: ... ye-hu be'ur megilat Shir ha-shirim / leha-Rav Mosheh Alshekh* (Venice: G. di Gara, 1591)
- Anshil, ספר של רבי אנשיל: והוא מרכבת המשנה לקונקורדנציה היותו מורכב משתי הלשונות לשון הקודש ולשון אשכנזי, *Sefer shel Rabi Anshil: ye-hu Merkevet ha-Mishnah le-ḵonḵordantsyah heyoto murkav mi-shete ha-leshonot leshon ha-ḵodesh u-leshon Ashkenazi* (Cracow, 1584)
- Aquin, Philippe d', Godefroy Hermant, Guy Michel Le Jay, Jean Theologian Morin, Ecchellensis Abraham, Sionita Gabriel, and Hispalensi, Joannes, *Biblia. 1. Hebraica, 2. Samaritana, 3. Chaldaica, 4. Græca, 5. Syriaca, 6. Latina, 7. Arabica. Quibus textus originales totius Scripturæ Sacræ, quorum pars in editione Complutensi, deinde in Antuerpiensi ... extat, nunc integri ... exhibentur* (Lutetiæ Parisiorum: Excudebat Antonivs Vitre 1645)
- , *Dictionarium absolutissimum*, (Paris: Antoine Vitre, 1629)
- Arama, Isaac ben Moses, *Sefer Hazut kashah* (Sabbioneta: Tuvyah Foah,, 1551)
- , מאיר על איוב: והוא פירוש על איוב ... / להחכם ... מאיר בן ... יצחק עראמה, *Me'ir lyov: ye-hu perush al lyov* (Venice: Giorgi di Cavalli, 1567)
- Arama, Meir ben Yitzhak, *Sefer Urim ve Tumin* (Venice: Daniel Zanetti, 1603)
- Archevolti, Samuel ben Elhanan Isaac, *Ma'yan Gannim* (Venice: Bragadin, 1553)
- , ערוגת הבשם: בדקדוק ... דרכי ... לשון הקדש ... הנקודות ... הטעמים ... במשקלי השירים ... / שמואל ארקוולטי, *'Arugat ha-bošem: be-diḵduk ... darkhe ... leshon ha-ḵodesh ... / Shemu'el Arḵevolti* (Venice: Giovanni di Gara, 1602)
- Arifol, Shemu'el, Mizmor le-todah: ... be-alfa beta rabati ... shire ha-maalot ... / Shemu'el ben Yitshak ... Arifol (Venice: Be-vet Zu'ani Digarah im otiyot ha-Bombergi,, 1576)
- Aripul, Samuel, ספר נעים זמירות: הוא פירוש נחמד על דרך הפשט על הט"ו שירי המעלות בפשטים עמוקים ... להחכם, *Sefer Ne'im zemirot: hu perush nehmad 'al derekh ha-peshaṭ 'al ha-15 shire ha-ma'alot bi-feshaṭim 'amukim* (Cracow: Isaac ben Aaron Prostitz, 1576)
- Aristotle and Segni, Bernardo (Tr.), *Rettorica, et poetica d'Aristotile*, Firenze, In presso Lorenzo Torrentino, 1549
- Asher, Jacob ben, *Arba'ah turim* (Augsburg (Oygsburg) Hayim Shahor ve-hatano Yosef u-veno Yitshak, 1540)
- , *Arba'ah turim* (Cremona: Vincenzo Conti, 1558)
- , Perush al ha-Torah / le-rabenu Yaakov baal ha-Turim ben ha-rav rabenu Asher. (Vinitiah: Giovan. dei Farri, bi-defus Cornelio Adelkind, 1544?)
- , *Yoreh De'ah* (Venice: Bragadin, 1551)
- , *Yoreh De'ah* (Venice: Giovanni Griffio/Grypho, 1564-67)
- Asher, Jacob ben, and Joseph ben Ephraim Karo, ספר אורח חיים: ... ועליו הבאור אשר חברו כמהר"ר יוסף, *Sefer Oraḥ ḥayim*. [Nidpas shenit] (Venice and Sabbionetta: Bragadin, 1563)
- , *Oraḥ ḥayim*: אורח חיים: הוא הטור האחד ... עם הביאור ... הכינו מהר"ר יוסף בה' אפרים קארו, קראו בית יוסף, *hu ha-Ṭur ha-eḥad ... / ... 'im ha-ve'ur ... hekhino ... Yosef ... Efrayim Ḳaro, kera'o Bet Yosef*. (Venice: Giustiniani, 1550-51/53-59)
- , *Arba'ah turim* (Constantinople: David and Samuel ibn Nachmias, 1493)
- , ארבעה טורים / לרבינו יעקב בן רבינו אשר, *Arba'ah ṭurim / le-rabenu Ya'aḳov ben rabenu Asher ...* (Hanu: Hans Jakob Henne, 1610)
- Asher, Jacob ben and Daniel Bomberg, ארבעה טורים / אשר חבר רבינו יעקב, *Arba'ah ṭurim / asher ḥiber rabenu Ya'aḳov* (Venice: Daniel Bomberg, 1522-23)

- Ashkenazi, Saul Cohen, Isaac Abravanel, Moses ben Judah Nagari, Mahmud Abubekhr ben Mahmud Tabrizi, and Joseph ben Abraham Gikatilla, *שאלות / להחכם כה"ר שאול הכהן ... שאל מאת החכם יצחק אברבנאל [תשובות להרב כה"ר יצחק אברבנאל]; פירוש קצת פרקים מספר מורה הנבוכים ... וקצת עניינים פילוסופיים ... מספר הכוונות [Teshuvot leha-Rav Yitshak]; perush ketsat perakim mi-Sefer Moreh ha-nevukhim* (Venice: Giovanni di Gara, 1574)
- Ashkenazi, Eliezer ben Eliah, *Ma'asei Hashem*, (Venice: Di Gara, 1583)
- Balmes, Abraham ben Meir, Kalonymus ben David, and Daniell Bomberg, *ספר דקדוק: ... קרא שמו מקנה / שהבר אברהם דבלמש (שער בטעמי המקרא לי ... קלונמוס בן דוד לבית קלונמוס Sefer Dikduk: ... kara shemo Mikneh Avram* (Venice: Bomberg, 1523)
- Balmes, Abraham ben Meir de, and Kalonymus ben David, *Mikneh Avram = Peculium Abrae: Grammatica Hebraea vna cum Latino* (Venetijs: Danielis Bobergi, 1523)
- Barfat, Isaac ben Sheshet, *Teshuvot ha-Rav ... Yitshak bar Sheshet* (Kushtantinah: Eliezer Sontsino, 1547)
- Bedersi, Jedaiah ben Abraham, and Philippe d'Aquin, *Behinat ha-'olam ... u-Fereq Avot ... va-ahar ba'u ha-13 midot = Examen du monde [Hebr. & Fr.]: Sentences morales des anciens Hebreux et les treize modes desquelles ils se servoient pour interpreter la Bible* (Paris, 1629)
- Bedersi, Jedaiah ben Abraham, Moses ben Solomon ibn Habib, and Joseph Francese, *... / בחינת עולם / עם פי' ר' משה נ' חביב ועם פירוש ... ר' יוסף פרנסיש ועם פירוש המימין מהר' יוסף פראנסיש הנזכר Behinat olam* (Ferrara, 1551)
- Bedersi, Jedaiah ben Abraham *ספר לשון הזהב / והוא ביאור מאמרי רז"ל ממדר' תלים ... / וביאור קצת מזמורים ממהר"ר יוסף ממהר"ר יוסף טיטצאק ותוכחה אחת להר' משה נ' עזרא ... כמה"ר ידעיה הפניני ...; וביאור קצת מזמורים ממהר"ר יוסף עזרא Sefer Lashon HaZahav* (Venice: Daniel Zanetti, 1599)
- Bellarmino, Roberto, *Institutiones Linguae Hebraicae* (Antwerp: Ex Officina Plantiniana, 1596)
- , *Institutiones Linguae Hebraicae* (Aureliae Allobrugum = Geneva: Apud Franciscum Fabrum, 1609)
- , *Institutiones Linguae Hebraicae* (Romae: Ex Officina Dominici Basae, 1585)
- Belon, Pierre, *Les Observations de plusieurs singularitez et choses memorables* (Paris: Hierosme de Marnef et la veuve Guillaume Cavellat, 1553)
- Ben Balam, Judah and Jean Mercier, *Sefer Ta'ami HaMikra/Liber de accentibus scripturae* (Paris: Henri Estienne, 1565)
- Ben Joseph, Isaac of Corbeil, *Amudei Golah [Semak]* (Cremona: Vincenzo Conti, 1556)
- Bertinoro, Obadiah, *Mishnayot mi-seder עובדיה מברטנורה / עם פירוש ... כמה"ר עובדיה מברטנורה, Mishnayot mi-seder Tohorot* (Venice: Carlo Querini, 1548)
- Bertram, Bonaventure Corneille, and Franciscus Vatablus, *Biblia sacra, Hebraice, Graece, & Latine. Latina interpretatio duplex est, altera vetus, altera noua: cum annotationibus Francisci Vatabli ... Omnia cum editione Complutensi ... collata, etc.* (Geneva: Ex officina Sanctandrea, 1587)
- Bertram, Corneille-Bonaventure, *Literæ Illustriss. Principis Ludovici Borbonii ... ad Carolum IX. Galliae regem, quibus ejus fidem implorat ... Ejusdem Testificatio causarum quæ eum arma sumere coegerunt ... Literæ Reginæ Navarræ ad regem Galliae ... quibus causas exponit cur sese principi Cōdæo cōjūxerit ... Narratio cædis in Lud. Borbonium ... perpetratae ... Varia variis linguis scripta in eundem epitaphia.* (Geneva: Henri Estienne the younger, 1569)
- , *Gal-Ed/Comparatio Grammaticae Hebraica* (Geneva: Eustache Vignon, 1574)
- Beveridge, William, *De Linguarum Orientalium praesertim Hebraica, Syriacae, Chaldaica, Arabicae & Samaritana* (Londini: Excudebat Thomas Roycroft, 1664)
- Bezalel, Judah Loew ben, *Tiferet Yisrael / le-Maharal mi-Prag* (Vinitsiyah: Daniel Zanitti, 1599)
- Beze, Theodore, and Antonius Rodolphus Cevallerius, *Alphabetum Hebraicum ... ex A. Cevallerii recognitione* (Geneva?: Excudebat Paulus Stephanos, 1600)
- Bèze, Théodore de, *Theodori Bezæ, Vezellii Poematum editio secunda, ab eo recognita. Item, ex Georgio Buchanano aliisque variis insignibus poetis excerpta carmina, presertimq; epigrammata* (Geneva: Excudebat Henr. Steph., 1569)

- Bèze, Théodore de, François the elder Du Jon, and Joannes Immanuel Tremellius, *Testamenti Veteris Biblia sacra, sive, libri canonici ... Latini ... facti ... ab Immanuele Tremellio & Francisco Junio. Accesserunt libri qui vulgo dicuntur Apocryphi, Latine redditi ... a F. Junio ... Quibus etiam adjunximus Novi Testamenti libros ex sermone Syro ab eodem Tremellio, & ex Græco a Theodoro Beza in Latinum versos ... Secunda cura F. Junii.* (Genevæ: apud I. Tornæsium: Genevæ; impensis A. Wecheli hæredum, C. Marnii & I. Aubrii: Francofurdi,, 1590 and 1596)
- Bodin, Jean, *Les Six Livres de la République* (Paris: Jacques du Puys, 1576)
- , *Les Six Livres de la République* (Lyon: Gabriel Cartier, 1593)
- Boeschenstein, Johann, *Contenta in hoc Astrologia ... Elementale introductorium in hebreas litteras teutonice & hebraice legendas. Decem precepta Exodi. XX. Oratio dominica Math. VI. Luce. XI., etc. Heb., Lat. & Ger* (Auguste [Augsburg]: Ex officina E. Oeglin, 1514)
- Bomberg, Daniel, המשה הומשי תורה *Ḥamishah ḥumshe Torah* [Nidpas hamishit] (Venice Daniel Bomberg, 1544-45)
- Bomberg, Daniel, Sa'adia ben Joseph, Moses ben Yom-Tov, Jacob ben Asher, David Kimhi, Perush Rashi Bal ha-Torah Rashi, Gershom Levi ben, Abraham ben Meir Ibn Ezra, Moses d ca Kimhi, and Jacob ben Hayyim ben Isaac ibn Adonijah, [Third] *Biblia Rabbinica* (Venice D. Bomberg, 1548)
- Bomberg, Daniel, Saadia ben Joseph, Moses ben Yom-Tov, Jacob ben Asher, David Kimhi, Rashi, Gershom Levi ben, Abraham ben Mei Ibn Ezra, Moses Kimhi, and Jacob ben Hayyim ben Isaac ibn Adonijah, אשר הטיב חסדו, יתברך המאיר מאישון, אשר הטיב חסדו *Yitbarakh ha-meir me-ishon, asher hetiv hasdo ... le-hair ha-saar le-hadpis Arba ve-esrim gadol paam shenit: ha-Humash veim Targum* (Venice: Daniel Bomberg, 1548)
- Broughton, Hugh, *Daniel, with a brief explication by Hugh Broughton* (Hanaw: By Daniel Aubri, 1607)
- , *An epistle of an ebrew willinge to learne Christianity sent by him to London: & thence, by the Archb. of Canterburies aduise, to Basil: thence returned vuith [sic] some further spech vpon it vnto the Quene of Englandes most excellent maiesty* (Basle: Connadus VValdkirch, 1598)
- , *Epistolae variae et variarum linguarum, de Byzantiacis hebraeis, discupientibus erudiri in Christi D. Sacro volumine, atque adeo de alio magno viro, quem nisi obliquè significare, Byzantij saltem non oportet, in re adhuc dubiâ. Argumenum docebit susius sequens pagina* (Basileae apud Conradum Waldkirch, 1599)
- , *Patshegen nishtevan ish ivri me-ir le-Konstantin mevakesh daat meshihenu im me-ḵitsat leqah el tètoto al yede Hugo Brogton.* (Amsterdam: 1606)
- , *A Concert of Scripture* (London: Richard Watkins for Gabriell Simson and William White, 1587-1591)
- , *Daniel his Chaldie Visions and his Ebrevv* (London: Richard Field for William Young, 1596)
- Buxtorf, Johann, *De Literis Hebraeorum* (Basle: Typis Martini Wagneri, 1643)
- , *Liber Cosri* (Basel: Georg Decker, 1660)
- Calvin, Jean, *Ḥinukh beḥire Yah / ḥibro Imanu'el Tremelli'us.* [Catéchisme de l'Eglise de Genève.Hebrew] (Geneva: H. Stephanus, 1554)
- Cappellanus, Claudius, *Mare Rabbinicum Infidum* (Paris: Apud Petrum Variquet, 1667)
- Cappel, Louis and Thomas Erpenius, סוד הניקוד הנגלה: *hoc est Arcanum punctationis revelatum. Sive De punctorum vocalium & accentuum apud Hebræos vera & germana antiquitate diatriba.* [By Louis Cappel.] In lucem edita a Thoma Erpenio (Lugduni Batavorum: I. Maire, 1624)
- Caro, Isaac ben Joseph, *Sefer Toldot Yitshak* (Mantua: Meir ben Efrayim/ Yaakov ben Naftali/Venturino Ruffinelli, 1558)
- , *Toledot Yitzhak: Perush al ha-Torah / Iehe-hakham Yitshak Karo* (Cracow: Prostitz, 1593)
- , *Sefer Toldot Yitzhak*, (Riva di Trento: Cardinal Christoforo Madrucci and Jacob Marcaria, 1558)
- Cellini, Benvenuto, *Due trattati, vno intorno alle otto principali arti dell'oreficeria. L'altro in materia dell'arte della scultura, etc.* (Fiorenza: Per V. Panizzij & M. Peri, 1568)

- Cevallerius, Antonius Rodolphus, and Joannes Immanuel Tremellius, *Rudimenta Hebraicæ linguæ, accurata methodo et breuitate conscripta. Eorundem rudimentorum praxis ... Omnia recognita & aucta ab ipso authore ... De Hebraica syntaxi canones generales, nunc primùm editi. Præfixa est epistola Hebræa ... Ioan. Immanuelis Tremellii, qua operis totius vtilitas copiosè demonstratur.* (Geneva: Excudebat H. Stephanus, 1567)
- Chabib, Ya'akov Shlomo, *Beit Ya'akov* (Venice: Giustiniani, 1547)
- Chelm, Solomon ben Moses, ספר מרכבת המשנה: אצל ... משה בר מימון ... הידושים ... ליישב ולתרגם השגות ... חיברו ר' שלמה אב"ד דק"ק חעלמא / *Sefer Mirkevet ha-Mishneh: etsel ... Mosheh Bar Maimon ... ĥidushim ... le-yashev ule-tarets haśagot ha-Rabad ve-he'arot ha-mefarshim ... / ĥibro Shelomoh a.b.d. de-ḳ.ḳ. Ĥelmah* (Frankfurt de-Oder, 1750-1782)
- Cinquearbres, Jean, *Torat ha-mashiah* (Paris: Apud M. Iuuenem, 1551)
- , *Linguae Hebraicae Institutiones Absolutissime* (Paris: Guillaume II Le Bé, 1609)
- , *De notis Hebraeorum liber*, (Paris: Martin le Jeune, 1582)
- Clenardus, Nicolaus, Nic. Clenardi, *Epistolarum Libri duo* (Antwerp: Ex Officina Christophori Plantini, 1567)
- Clénard, Nicolas, *Tabula in grammaticen hebraeam autore Nicolao Clenardo* (Paris: Chrétien Wechel, 1543)
- Colon, Joseph, *Teshuvot - Barukh adon ha-metsiut* (Viniziyah: Al yede he-ahim bene Barukh Edel Kind be-mitsvat uve-vet Daniel Bombirga, 1519)
- Cornelius, Heinrich, *De occulta philosophia I* (Paris: Chrétien Wechel, 1531)
- Cotgrave, Randle, *A Dictionarie of the French and English tongues*. (London: Adam Islip, 1611)
- Cousin, Jean, *La vraye science de la pourtraicture descrite et démontrée* (Paris: Guillaume Le Bé, 1671)
- De Pomis, David, *Tsemach David /Dictionario Novo/Lexicon Novvum Hebraicum* (Venice: Giovanni di Gara, 1586)
- Desprez, Philippe, *Le théâtre des animaux, auquel sous diverses fables et histoires est représenté la pluspart des actions de la vie humaine* (Paris: chez Guillaume Le Bé, 1644)
- Du Jon, François the elder, and Joannes Immanuel Tremellius, *Bibliorum pars prima, id est, quinque libri Moschis. (Pars secunda, id est, libri historici, etc.-Pars tertia, id est, quinque libri poetici, etc.-Pars quarta, id est, prophetici libri omnes, numero xvi., etc.) Latini recens ex Hebræo facti, brevisque scholiis illustrati, ab Immanuele Tremellio & Francisco Iunio.* (Francofurti ad Moenum: A. Wechelus:, 1575-79)
- , *Bibliorum pars tertia, id est, quinque libri Moschis. (Pars secunda, id est, libri historici, etc.-Pars tertia, id est, quinque libri poetici, etc.-Pars quarta, id est, prophetici libri omnes, numero xvi., etc.) Latini recens ex Hebræo facti, brevisque scholiis illustrati, ab Immanuele Tremellio & Francisco Iunio. (Libri Apocryphi, sive appendix Testamenti Veteris ... latina ... facta, & notis brevis illustrata per F. Iunium.)* (Francofurti ad Moenum: A. Wechelus, 1579)
- Dueren, Isaac ben Meir, *Pithu shearim ve-yavo goi tsedek shomer emunin ... Shaare Dura ... / Shelomoh Luria ben Yehiel hideshow devarim rabim; ... amarti .. le-hadpis li-zekhut ha-rabim ... Elia ben Mosheh Loants* (Basilia: Bi-defus Konrad Valdkilch, 1599)
- Dueren, Isaac ben Meir, and Israel ben Pethahiah Isserlein, *Sefer Shaare Dura: ha-nikra Isur ve-heter* (Venice: Meir di Parenzo, 1547)
- Edels, Samuel Eliezer ben Judah, ha-Levi, *Ĥidushim mi-masekhet Yom Ṭov u-masekhet Yevamot .u-ve'ure halakhah shonim* (Basel, Bi-defus Konrad Valdkilch uve-veto, 1599)
- Eliezer ben Hyrcanis, פרקי רבי אליעזר, *Pirḳe Rabi Eli'ezer* (Venice: Giovanni di Farri and Brothers, 1544)
- Eliezer, ha-Gadol, and Nissim ben Jacob ben Nissim ibn Shahin, *Alfa beta de-Ven Sira* (Venice: Giovanni di Farri and Brothers, 1544)
- Eliezer, Toviyaahu ben, *Pesikta zutarta* (Venetsyah: Daniyel Bombirgi, 1546)
- Erpenius, Thomas, *Grammatica Ebræa generalis* (Lugduni Batavorum [Leiden]: Typis Raphelengius/Johannes Le Maire, 1621)

- Haneken, Meno, *Menonsis Hannekenii Grammatica linguae Hebraeae* (Frankfurt: Christoph Wust, 1676)
- Harizi, Judah ben Solomon, *Mishle hakhamim* (Venezia: Giorgio dei Cavalli, 1566?)
 ———, דער קליין ברנט שפיגל, ... ספר משלי חכמים: *Sefer Mishle hakhamim: ... der kleyn brant shpigl* (Hamburg?, 1698)
- Helwig, Christoph, *Elementale Hebraicum et Chaldaicum* (Gießen :Kaspar Chemlin, 1619)
- Hlava, Bahya ben Asher ben, *Be'ur al ha-Torah Sefer Rabenu Bahye* (Pizaro: Bi-defus Gershom Sontsino, 1514)
 ———, *Rabenu Bahye: beyur al ha-Torah le.hakham ha-kolel* (Vinitsyah be-veyt Daniel Bombirgi, 1546?)
 ———, *Rabenu Bahye: beyur al ha-Torah le.hakham ha-kolel*. (Vinitsyah be-veyt Zoan .Kavali, 1566?)
 ———, *Be'ur al ha-Torah*. (Venice: Giovanni di Gara., 1544)
 ———, *Shulhan arba* (Venice: Be-vet Marko Antonio Yustinian, 1545)
- Houbigant, Charles-François, *Psalmi hebraici mendis quam plurimis expurgati* (Leiden/Avilly: 1743)
- Humphrey, Laurence, *Ioannis luelli Angli, Espicopi Sarisburiensis vita & mots eiusq[ue] ...* (Londini: Apud Iohannem Dayum typographum, 1573)
- Ibn Tibbon, Shmuel, Isaac Abravanel, and Moses Maimonides, עם פירוש, *Pirkei Avot: im perush ... Rabenu Mosheh bar Maimon ve-im perush Don Yitshak Abravanel ve-kara be-shem ... Nahalat Avot* (Venice: Giustiniani, 1545)
- Ibn Zarza, Samuel, *Sefer Mekor hayim: beur al ha-Torah ... le-havin ... divre ... Avraham n. Ezra veba-Rambam / Shemuel Tsartsah Shats ha-mekhuneh bi-leshon kodesh Ibn Seneh* (Mantovah: Ha-Shutafim Meir ben Efrayim ve-Yaakov ben Naftali ha-Kohen, 1559)
- Isaac, Baruch ben, and Daniel Bomberg, ספר התרומה *Sefer ha-Terumah* (Venice: Bomberg, 1523)
- Isaac ben Jacob Joseph, ha-Levi of Herlesheim, כמנהג ק"ק אשכנזים, *Mahazor: ke-minhag k.k. Ashkenazim* (Venice: Zan Bragadin and Zan de Garah, 1599-1600)
- Isserlein, Israel ben Pethahiah, *Terumat ha-deshen* (Venice: Março Antonio Yuštinyan, 1546)
 ———, *Be'urim ... al perush Rashi: be-hamishah humshe Torah* (Venice: Marc'Antonio Giustiniani, 1545)
- Isserlein, Israel ben Pethahiah, and Daniel Bomberg, ספר תרומת הדשן / חבר ויסד ... מהר"ר ישראל זצ"ל ... *Sefer Terumat ha-deshen* (Venice: Daniel Bomberg, 1519)
 ———, *Pesakim u-khetavim / shel Yiśra'el* (Venice: Daniel Bomberg, 1519)
- Isserless, Moses ben, משה בן רבי אסרל / ... *Zot torat ha-ḥaṭat: sefer kolel kol dine isur ve-heter ... / Mosheh ben Rabi Iserl* (Hanau: Eliahu ben Yehuda and Avraham bar Yehezkiel HaCohen, 1628)
- Jehiel, Asher ben, *She'elot u-teshuvot / ye-nityasef...mar'eh maqom...Me'ir [ben] Yaaqov ish Prints* (Venice Nidpas be-vet Al'izi Bragadin, 1552)
- Jehiel, Nathan ben, *He-Arukh* (Venice: Nidpas be-mitsvat El'ysi Bragadin, 1553)
- Judah, ha-Levi, and Yehudah ibn Tibon, כוזרי *Kuzari* (Venice: Meir di Parenzo, 1547)
- Junius, Franciscus, *Francisci Iunii grammatica hebraeae linguae* (Geneva: apud Ioan. Tornaesium/Imp. And. Wecheli Haeredum, 1596)
- Karo, Joseph ben Ephraim, and Giorgio de Cavalli, יוסף ... *Shulhan 'arukh: meha-Arba' ṭurim ha-nikra Bet Yosef* (Venice: Z. de Cavalli, 1567)
- Karo, Joseph ben Ephraim Bet Yosef, יוסף, הנקרא בית יוסף, [חושן המשפט] *Shulhan 'arukh mi-ṭur Oraḥ ḥayim [Hoshen ha-mishpat] ha-nikra Bet Yosef* (Venice: J. Grypho, 1567)
 ———, *Shulhan 'arukh mi-ṭur Oraḥ ḥayim [Hoshen ha-mishpat] ha-nikra Bet Yosef* (Venice: Bragadin, 1565)
 ———, *Sefer Shulhan Arukh* (Venice: di Cavalli, 1567)
- Katsenelenboigen, Shemuel Yehudah, Asher ben Jacob Parenzo, and Giovanni Di Gara, שנים עשר *Shenem Asar derashot* (Venice: Asher ben Jacob Parenzo and Giovanni Di Gara, 1594 and 1596)

- Kimhi, David, *Sefer Mikhlol / she-hiber ... David Kimhi... ketsat nimukim she-hosif ... Eliyah Ashkenazi ... u-vo yevoar kol helke ha-dikduk*. (Venetsyah [Venice]: Nidpas be-vet Daniel Bombirani (Bomberg), 1545)
- , ספר השרשים *Sefer ha-shorashim ...: ve-hu helekh shene me-sefer ha-mikhlol u-vazah ha-helekh yevaer kol melah kasheh asher be-sefer Torah Neviyim ve-Ketuvim im ketsat nemukim she-hosif Eliyah ha-Levi* (Vinitiah [Venice]: ba-Bet A. Yoshtinian (Giustiniani), 1546)
- Kimhi, David, ספר השרשים *Sefer ha-shorashim: ... helek sheni meha-Mikhlol ... im ... nimukim she-hosif ... Eliyah ha-medakdek ...* (Venice Be-vet... Marqo Antoni'o Yuštini'an, 1547-48)
- Kimhi, David, and Daniel Bomberg, ספר השרשים *Sefer ha-shorashim: ve-hu ha-helek ha-sheni meha-Mikhlol* (Venice: Daniel Bomberg, 1546)
- Kimhi, David, Isaiah ben Eliezer, and Daniel Bomberg, ספר השרשים *Sefer ha-shorashim* (Venice: Daniel Bomberg, 1529)
- Kimhi, David, da Prato Felice, Nahmanides, Perush Rashi Bal ha-Torah Rashi, Daniel Bomberg, Abraham ben Mordecai Farissol, Gershom Levi ben, Moses Maimonides, Aaron ben Moses Ben-Asher, and ha-Darshan mi-Frankfort Shimfon, , ארבעה ועשרים: חומש עם תרגום אונקלוס ועם פירוש רש"י, נביאים ראשונים ונביאים אחרונים עם תרגום יונתן ועם פירוש רד"ק, תהלים עם תרגום ועם פירוש רד"ק, משלי עם פירוש קב ונקי, איוב עם פירוש הרמב"ן ור"א פריצול, חמש מגילות עם תרגום ועם פירוש רש"י, דניאל עם פירוש רלב"ג, עזרא עם פירוש רש"י ושמעוני, דברי הימים עם רש"י ושמעוני, תרגום ירושלמי על החומש ותרגום אחר על מגלת אסתר ושערי הטעמים וההפרשות שבין בן אשר ובן נפתלי: שלש עשרה עקרים שחבר הרמב"ם, מצות עשה ולא אברהם 'Arba'ah ve-'esrim תעשה לר' אברהם 'חסאן הלוי, ספר מדקדוקי הטעמים שהחביר ר' אהרן בן אשר ממקום מעוזה *Humash 'im Targum Onkelos ve-'im Perush Rashi, Nevi'im rishonim ve-Nevi'im aḥaronim 'im Targum Yonatan ben 'Uzi'el ve-'im perush David Kimḥi, Tehilim 'im Targum Rabi Yosef ve-'im perush Radak, Mishle 'im Targum Rabi Yosef ve-'im Perush Kav ve-naḳi, Iyov 'im Targum Rabi Yosef ve-'im perush ha-Ramban ve-Rabi Avraham Paritsol, Hamesh megilot 'im Targum Rabi Yosef ve-'im Perush Rashi, Dani'el 'im perush Rabi Levi ben Gershom, 'Ezra 'im Perush Rashi ve-Shim'oni, Divre ha-yamim 'im Perush Rashi ve-Shim'oni, Targum Yerushalmi 'al ha-Humash ve-targum aḥer 'al Megilat Ester ve-Sha'are ha-ṭe'amim vaha-hafrashot she-ben Ben Asher u-Ven Naftali: Shelosh 'esreh 'ikarim she-hjber ha-Rambam, Mitsvot 'aseh ve-lo ta'aseh le-R. Avraham n. Hasan ha-Levi, Sefer mi-Dikduke ha-ṭe'amim she-heḥbir R. Aharon ben Asher* (Venice: Daniel Bomberg, 1517)
- Kimchi, David, and David ben Solomon Ibn Yahya, עם פירוש ר' דוד קמחי ועם פירוש ר' יוסף חיון *Sefer Tehilim: 'im perush R. David Kimḥi ve-'im perush R. Yosef Hayun (Mishle perush sefer mishle ha-nikra kav ve-naḳi [By David ben Solomon Aben Yachya]* (Thessalonika: J. Gedaliah, 1522)
- Kimchi, David, Moses Kimhi, Jacob ben Hayyim ben Isaac ibn Adonijah, Saadia ben Joseph, Rashi, Gershom Levi ben, Abraham ben Meir Ibn Ezra, Moses ben Yom-Tov, and Daniel Bomberg, *Torah Neviim u-Khetuvim* (Venice: Daniel Bomberg, 1524-25)
- Kimchi, David, and Elijah Levita, ספר השרשים *Sefer ha-shorashim: ... ve-hu helek ha-sheni mi-sefer ha-Mikhlol* (Venice: Giustiniani, 1546-48)
- Kimchi, David, ספר השרשים *Sefer ha-shorashim* (Salonica: G. Soncino, 1533)
- Kimchi, David, Franciscus Vatablus and Robert Estienne, חמשה חומשי תורה וכו' *Hamishah ḥumshe Torah ...* (Paris: Robert Estienne, 1539-44)
- Koppelman, Jakob ben Samuel, משלי ספר שועלים *Sefer Mishle Shu'alim / Das Buch der Fuchsfabeln* (Freiburg im Breisgau: Zifroni, 1583)
- , אהל יעקב *Ohel Ja'akov* (Freiburg im Breisgau: Zifroni, 1583/4)
- , תרגום של חמש מגילות *Targum shel chamesh Megilot* (Freiburg im Breisgau: Zifroni, 1584)
- Kyber, David, *De re grammatica Hebraea linguae, libri tres* (Basileae: per Henrichum Petri, 1552)
- Ladocat, Jean-Baptiste, *Grammaire Hébraïque* (Paris: Humblot, 1755/56)
- Landau, Yacob ben Judah, *Sefer Agur* (Venice: Giustiniani, 1546)
- Le Bé, Guillaume, *Epreuves de lettres que j'ay taillées, tant en six et sept sortes de poisons de lettres hebraïques, que autres lettres, en divers temps et pour diverses personnes et partie aussy pour moy* (Paris: Bibliothèque Nationale, ?).N.A. fr-4528
- Le Bé, Guillaume, *The Le Bé-Moretus collection of fragments*, St Bride Library, 1599)

- Le Bé, Guillaume, *Spécimens de caractères hébreux gravés à Venise et à Paris par Guillaume Le Bé* (1546-1574) (Paris: Bibliothèque nationale,?).RES- X- 1665
- Le Fèvre de la Boderie, Guy, *דִּיִּתִּיקָא הַדָּתָא Diyatiqa ḥadata: he kaine diatheke / Novum Jesu Christi D.N. Testamentum; ad christianiss. Galliae et Poloniae regem Henricum III ... principem, christianae religionis vindicem & assertorem unicum* (Paris: Jean Benenatum, 1584)
- , *Dictionarium Syro-Chaldaicum*.-Grammatica Chaldæa (Antwerp: Christophe Plantin, 1573)
- Léon, Moshe de, *Zot HaSefer HaNefesh HaHochma* (Basle: Waldkirch, 1608)
- Levi, ben Gershom, *Perush Hamesh Megilot* (Riva di Trento: Christopher Madrutz, 1560)
- Levi, ben Jacob ben Chabib, *She'elot u-teshuvot*. (Venice Giovanni di Gara, 1565)
- Levi, Solomon ben Isaac, *Divre Shelomoh: Helek rishon mi-Sefer Divre Shelomoh* (Vinitzsyah: be-vet M. Zaniti ve-K. Priziniyo, 1595/1596)
- Levita, Elijah, *Meturgeman: lexicon chaldaicum / authore Eliia Levita, quo nullum hactenus a'quoquam absolutius aeditum est, omnibus Hebraeae linguae studiosis inprimis & utile & necessarium* (Isny: Paulus Fagius, 1541)
- , *Sefer ha-harkavah: composita verborum & nominum Hebraicorum / opus uere in signe atque Hebraic, Grammaticae studiosis in primis necessariu Romae Elia Leuita autore aeditum & nuper per Sebastianum Munsterum Latinitate donatum* (Basileae: Henricum Petrum?, 1525)
- , *ספר מסורת המסורת: ... להבין ... דרך בעלי המסורות / חברו אליהו בן אשר הלוי האשכנזי, Sefer Masoret ha-masoret: ... le-havin ... derekh ba'ale ha-masoret / ḥibro Eliyahu ben Asher ha-Levi ha-Ashkenazi* (Venice: Daniel Bomberg, 1538)
- Levita, Johannes Isaac, *Grammatica Hebraea absolutissima*, [Editio Quinta] (Antwerp: Christophe Plantin, 1570)
- , *De Astrologia: Rabbi Mosis filii Meimon epistola* (Coloniae: per Iacobum Soterem, 1555)
- Loanz, Elijah, *Rinat dodim: be'ur al Shir ha-Shirim*. (Basle: Be-vet Konrad Valdkirkh, 1600)
- Lonzano, Menahem ben Judah de, *Derekh hayim* (Constantinople 1570?)
- Luria, Isaac ben Solomon, *להרב יצחק לוריא, ספר הכונות / Sefer ha-kavanot / leha-rav Yitshak Lurya* (Venice: Lorenzo Bragadin, 1620)
- Luzzatto, Ya'akov ben Itzhak, *Sefer Kavanot ha Haggadot nikra Kaftor u-Ferah* (Basle: Ambrosius Frobenius and Israel Zifroni, 1580)
- Maimonides, Moses, *משנה תורה Mishneh Torah* (Venice: Daniel Bomberg, 1522)
- , *Igrot leha-ma'or ha-gadol, ha-ner ha-ma'aravi*. [Nidpas shenit] (Venice, 1545)
- , *Mishneh Torah: hu sefer yad ha-ḥazakah: im tsiyunim meha-Riḥba: ye-im hagahot ha-Ramakh u-Maharam mi-Padova* (Venice: Giustiniani, 1550)
- , *... מורה נבוכים: ... עם פירוש שם טוב ועם פירוש האפודי ושער אחד יודיע בו כוונת כל פרק מפרקי המורה, Moreh nevukhim: ... 'im perush Shem tov ve-'im perush ha-Efodi ve-sha'ar ehad yodia' bo kavanat kol pereḳ mi-pirḳe ha-Moreh* [By Judah ben Solomon Charizi] (Venice: Bragadin, 1551)
- , *Mishneh Torah: ... ha-Yad ha-ḥazakah* (Venice: Bragadin, 1574-1575)
- Maimonides, Moses, Meir ben Isaac Katzenellenbogen, and Alvis Bragadin, *משנה תורה: היד החזקה, Mishneh Torah: ha-Yad ha-ḥazakah ...* (Venice: A. Bragadin, 1550) also (1574-75)
- Manoah, Hezekiah ben, *Hazekuni: perush al Hamishah humshe Torah* (Kremonah: Vincenzo Conti, 1559)
- Mat, Moses, *Mateh Mosheh* (Cracow: ? Prostitz, 1591?)
- Mattathias, Benjamin Zeev ben, Mattathias ben Benjamin, Jacob ben Mattathias Foa, and Daniel Bomberg, *זה הספר נקרא שמו בישראל בנימין זאב Zeh ha-sefer nikra shemo be-Yisrael Binyamin Zeev* (Venice: Bomberg, 1539)
- Mantius, Aldus, *Introductio utilissima hebraice discere cupientibus* (Venice: Aldus Manutius, 1500)
- Mayr, Georg, *Institutiones Linguae Hebraicae* (Lyon: Antoine Jullieron, 1649)
- , *Institutiones Linguae Hebraicae* (Augustae Vindelicorum [Augsburg], Christoph Mangius, 1626)
- Me'ir, Qalonymos ben Qalonymos ben, *Even bohan* (Vinitzsyah: Cornelius Adelkind, 1546?)
- Meiri, Meir ben Jacob, *ההלכה להבין כל השמנה בנינים מהשלמי' בנקודתם, Heh lekha poh simane kol ha-shemonah binyanim* (Sabbionetta, 1554)
- Melli, R. Eliezer, *LeKhol Hefetz* (Venice: Adelkind, 1552)

- Mercerus, Joannes, *Cantica eruditionis intellectus, auctore ... R. Haai ... & Paropsis argētea, auctore Iosepho Hyssopeo. Cum Latina interpretatione per Ioannem Mercerum* (Parisiis: Apud Gulielmum Morelium, 1559)
- Mercier, Jean, Besorath Mattay: *Evangelivm Hebraicum Matthæi, recens e Iudæorum penetralibus erutum, cum interpretatione Latina, ad vulgatum quoad fieri potuit, accommodata* (Paris: Martin Le Jeune, 1584)
- Mizrahi, Elijah, Israel ben Elijah Mizra'i, and Daniel Bomberg, *פירוש רש"י / מהגאון ... אליא מזרחי Perush Rashi* (Venice: Daniel Bomberg, 1527)
- Modelius, Georgius Leonhartus, *Mnemonema Historicum Montrans* (Vindshemiae [Bad Windsheim], Typis Christophori Redelhameri, 1685)
- Molln, Jacob ben Moses, *Maharil me-reshit ha-shanah ve-ad aharit ha-shanah minhagei k"k ashkenaz* (Cremona: Vincenzo Conti, 1558)
- , מהר"ל: הוא יעקב בן משה הלוי, שחבר ותקן מנהגי ק"ק אשכנז ... מראשית השנה ועד אחרית השנה, ונתוסף עליו, *Maharil / hu Ya'akov ben Mosheh ha-Levi, she-ħiber ve-tiken minhage ħehilot Ashkenaz ... ve-nityasef 'alay ... hagahot ... Hirts Levi* (Hanau: Eliahu ben Yehuda and Avraham bar Yehezkiel HaCohen, 1628)
- Mordecai ben Hillel, ha-Kohen, *Hilkhot shehitah u-vedikah* (Venice: Daniel Adelkind, 1550)
- Mordekhai ben Yaakov, mi- Toyplits, אויז גיליגט אויף טייטש *Sefer Mishle: oyz gelegt oyf Taytsh ... un yil pshořim fun der Gemore* (Cracow: Isaac ben Aaron Prostitz, 1582)
- Mordekhai, ha-Kohen, *Siftei Kohen* (Venice: Daniel Zanetti, 1605)
- Mordekhai, Shelomoh ben, ספר מזבח הזהב, *Sefer Mizbah ha-zahav* (Basle: Konrad Waldkirch, 1602)
- Moses ben Isaac, of Bisenz, *Sefer derash mosheh* (Cracow: Isaac Prosnitz, 1589)
- Nahman, Moshe ben, *Sefer Igeret ha-Kodesh*, (Rome: Benjamin ben Joseph d'Arignano, Isaac de Lattes in partnership with Antonio Blado, 1546)
- Nachmanides, *Be'ur al ha-Torah* (Venice: Giustiniani, 1545)
- Nahshon ben Zadok, Ga'on, *Reumah: medaber bitsda.kah rav ha-ikhut be-dine she.hi.tah u-vedikah* (Kushtantina [Constantinople], 1565)
- Narkiss, Bezalel, and Leone Modena, *Seder Hagadah shel Pesach*, .Venetsyah 369 = The Passover Haggadah, Venice 1609 (Jerusalem: Makor, 1974)
- Nathan ben Jehiel, of Rome, *Sefer ha-Arukh ... / hiberio ... Natan ben Yehiel me-ir Romi. Ve-nosaf bezeh al ha-nipasi' me-az ha-moreh makom ve-kol zeh mesudar, a.y. Shemuel ben Elhanan Yaakov min ha-Arkvolti* (Basiliah: Konrad Valdkirch, 1599)
- Natan, Mordecai, *Concordantias Hebraicas / שחיבר החכם המובהק רבי מרדכי נתן* (Venice: Bragadin, 1564)
- Nehemiah, Issar Judah ben, ספר עזרת יהודה: הוא שאלות ותשובות וחדושים בארבע חלקי הש"ע ... / איסר יהודה, *Sefer 'Ezrat Yehudah: hu sh. u-t. ve-ħidushim be-arba' ħelĕ ha-Sh. 'a. ... / Isar Yehudah beharav Neħemy. ... po Brisk* (Varsha: Tsevi Yaakov Bomberg, 1862)
- Neufville, Jean de, *Ioannis Neovillei Genvillani in septem Davidis Psalmos quos poetentiales vocant, commentarii* (Paris: André Wechel and Galiot du Pré, 1556)
- Obadiah, Hayyim ben Jacob, *Beer mayim hayim* (Saloniki: 1546)
- Osiander, Lucas, *Dictionarium Hebraicum e concordantiis Hebraeis* (Basileae: Per Samuelem Regium, 1569)
- Oxford University Press, *A Specimen of the Several Sorts of Letters given to the University by Dr. John Fell* (Oxford, 1695)
- Pachymere, Georgius, *Paraphrasis in decem epistolas B. Dionysii Areopagitae* (Paris: Claude Chevallon and Charlotte Guillard, 1538)
- Pagnini, Sante, *Biblia Hebraica* (Leiden: Ex officina Plantiniana Raphelengii, 1613)
- , *Observationes in linguam Hebraicam: ad simplicem Sacrarum literarum intelligentiam admodum necessariae / Sancte Pagnino Lucensi auctore*. (Lvtetiae: Ex officina Roberti Stephani typographi Regij, 1546)
- , *Hoc est, Epitome Thesauri Linguae Sanctae, autore Sante Pagnino Lucensis* [Compiled by F. Raphelengius] (Antwerp: Christophe Plantin, 1570)
- Pagninus, Sancte, *Thesaurus Linguae Sanctae* (Geneva: Pierre de la Rouvière, 1614)
- , *Thesauri Hebraicae Linguae* (Antwerp: Christophe Plantin, 1572)

- Palatino, Giovambattista, *Libro di M. Giovambattista Palatino, cittadino romano* (Rome: Antonio Blado, 1550)
- Palma Cayet, Pierre Victor, *Paradigmata de quatuor linguis Orientalibus præcipuis Arabica, Armena, Syra, Æthiopica* (Parisiis: E Typographia Steph. Prevosteau, haeridis Guil. Morelij, 1596)
- Pantheus, Joannes Augustinus, *Ars et Theoria Transmutationis Metallicæ cum Voarchadumia (contra alchimia: ars distincta ab archimia et sophia): proportioibus, numeris, & iconibus rei accomodis illustrate* (Parisiis: Apud Vincentium Gaultherotum, 1550)
- Pantheus, Joannes Augustinus, and John Dee, *Voarchadumia contra Alchimiam: ars distincta ab archimia, & sophia: cum additionibus: proportioibus: numeris: & figuris opportunis* (Venetiis: Giovanni Tacuino, 1530)
- Parenzo, Asher ben Jacob, and Rashi, *המשה הומשי תורה Hamishah ħumshe Torah* (Venice: Bragadin, 1590)
- Perets, and Judah ben Jacob Hayyat, *Sefer Ma'arekhet ha-elohut* (Ferrara: Avraham Usque, 1557)
- Plantin, Christoffel, *Index librorum qui Antverpiæ in officina C. Plantini excusi sunt*. MS. Notes (Ex officina Christophori Plantini: Antverpiæ, 1575)
- , *Index librorum qui ex Typographia Plantiniana prodierunt* (Antverpiæ, 1615)
- Pomis, David ben Isaac, *de Tsemah David; u-vo hitsmiah u-farash be'er hetev be-kitsur be-shloshah leshonot kol shores milah u-milah she-matsa be-sefer ha-arokh ha-gadol = ditionario novo hebraico, molto copioso, dechiarato in tre lingue ... = Lexicon novum hebraicum ... / David de Pomis = David, Rofe ... mi-mishpahat ha-Tapuhim* (Venetiis: Ex officina Ioannem de Gara, 1586)
- , *Kohelet = L'Ecclesiaste di Salomone: nuouamente dal testo hebreo tradotto, et secondo il uero senso nel uolgar idioma dichiarato* (Venetia: G. Ziletti e compagni, 1571)
- Porto, Abraham Menahem ben Jacob, ha-Kohen, *Minhah belulah: ve-hu perush al Hamishah Humshe Torah / yisdo ve-hibro...R. Avraham Menahem ben Yaakov Kohen Rafa mi-Port...sham balal ha-mehaber mivhar ha-midrashot veva-peshatim...* (Verona Frantsisko Di li Doni, 1594)
- Postel, Guillaume, *De Foenicum literis, seu de prisco Latine et Grece lingue caractere, eiusque antiquissima origine et usu ... commentatiuncula* (V. Gaultherot: Parisiis, 1552)
- , *G. Postelli ... de originibus seu de Hebraicæ Linguæ et Gentis antiquitate, deque variarum linguarum affinitate liber, etc.* (Paris, 1538)
- , *Linguarum duodecim characteribus differentium Alphabetum, introductio, ac legendi modus, etc* (Paris: Chez Denys Lescuir, 1538)
- Postel, Guillaume, Gioune Paulo Loredano, Conradus Pellicanus, and François Secret, *Interpretation du candelabre de Moyse.* [Guillaume Postel, 1510-1581, et son Interpretation du candelabre de Moyse en hebreu, latin, italien et francais, (Venice: 1548) (Nieuwkoop: B. de Graaf, 1966)
- Portaleone, Abraham ben David, *ספר שלטי הגבורים : ושלשה מגינים למלחמתה של תורה ערוכים ... / הכינו וגם Sefer Shilṭe ha-giborim: u-sheloshah meginim le-millĥamtah shel Torah 'arukhim ... / hekhino ye-gam ĥikro Avraham ha-Rofeh ben David mi-Sha'ar Aryeh. .* *Mantovah* (Mantua: 1612)
- Premsla, Moshe ben Avraham, *Sefer Mateh Mosheh* (Cracow: Prostitz, 1591)
- Potken. Johann, *Psalterium in quator linuis Hebraea, Chaldaea, Latina* (Coloniae: 1518)
- Pseudo-Bahya, *Sefer hovot ha-levavot* (Mantovah: Meir ben Ephraim & Jacob ben Naphtali ha-Kohen, 1559?)
- Rashi, Daniel Bomberg, Asher ben Jehiel, and Moses Maimonides, *מסכת ברכות: עם פירוש רשי ותוספות Masekhet berakhot [-Nidah]: im perush Rashi ve-Tosfot u-Fiske tosfot u-Ferush ha-mishnayot ve-Rabenu Asher* (Venice: Bomberg, 1520-1523)
- Rashi, Asher ben Jehiel, Moses Maimonides, and Daniel Bomberg, *מסכת ברכות [-נידה]: עם פירוש רשי ותוספות Masekhet berakhot [-Nidah]: ... 'im perush Rashi ye-Tosfot.* [2nd. ed.] (Venice: Bomberg, 1526-1539)
- Rashi, and Daniel Bomberg, *מסכת ברכות: עם פירוש רשי ותוספות Masekhet Berakhot: 'im perush Rashi ye-tosafot ...* (Venice: Bomberg, 1548)
- Rashi, Asher ben Jehiel, Marco Antonio Giustiniani, and Moses Maimonides, *מסכת ברכות: עם פירוש רשי ותוספות Masekhet Berakhot: 'im perush Rashi ye-tosafot ...* (Venice: Giustiniani, 1546-1550)

- Rashi, and Hezekiah ben Manoah, המשה המשי תורה *Hamishah humshe Torah: im targum u-ferush Rashi* (Venice: Daniel Bomberg, 1524)
- Rashi, Daniel Bomberg, Nahmanides, and Isaac Aboab, המשה הומשי תורה *Hamishah Humshe Torah: 'im Targum u-ferush Rashi u-ferush Rabenu Mosheh bar Nahman Gerondi 'im perush Rabi Yitshak Abuhab 'al perusho va-Hamesh megilot va-Haftarot*. (Venice: Daniel Bomberg, 1548)
- Raynolds, John, Johannis Rainoldi Angli, *De Romanae ecclesiae idololatria, in cultu sanctorum, reliquiarum, imaginum, aquae, salis, olei, aliarumque rerum consecratarum, et sacramenti Eucharistiae. Operis inchoati libri II. In quibus cum alia multa variorum papismi patronorum errata patefiunt: tum inprimis Bellarmini, Gregoriquae de Valentia, calumniae in Calvinum ac ceteros protestantes, argutiaeque pro papistico idolorum cultu discutiuntur et ventilantur* (Geneva: Jacob Stoer, 1598)
- , *Johannis Rainoldi Angli, De Romanae ecclesiae idololatria, in cultu sanctorum, reliquiarum, imaginum, aquae, salis, olei, aliarumque rerum consecratarum, et sacramenti Eucharistiae. Operis inchoati libri II. In quibus cum alia multa variorum papismi patronorum errata patefiunt: tum inprimis Bellarmini, Gregoriquae de Valentia, calumniae in Calvinum ac ceteros protestantes, argutiaeque pro papistico idolorum cultu discutiuntur et ventilantur* (Oxonae: Apud Josephum Barnesium, 1596)
- Recanati, Menahem ben Benjamin, ביאור על התורה: על דרך האמת ... / ... מנחם מרקנאטי ... עם תוספת איזה ... מאמרי הזוהר *Be'ur 'al ha-Torah: 'al derekh ha-emet ... / ... Menaḥem mi-Reḳanaṭi ... 'im tosefet ezeḥ ma'amre ha-Zohar* (Venice: Giustiniani, 1545)
- Reuchlin, Johannes, *De rudimentis hebraicis* (Pforzheim: Thomas Anshelm, 1506)
- Reuven of Gerona, Rabbi Nissim ben, *She'elot u-Teshuvot ha-Rav ha-Gadol ha-Ga'on Rabeinu Nissim Girondi* (Rome: Benjamin ben Joseph d'Arignano, Isaac de Lattes in partnership with Antonio Blado, 1546)
- Rittangel, Johan יצירה ספר *id est Liber Ierzirah* (Apud Johannum et Jodocum lanssonios, (Amsterdam, 1642)
- Saba, Abraham ben Jacob, *Beur al ha-Torah / shehiber ha-hakham ha-shalem* (Vinitsiyah ba-Bet M.A. Yoshtinian, 1546)
- , פירוש על התורה / שחיבר החכם השלם רבי אברהם סבע וקרא שמו צרור המור; מיוסד על פשט התורה וקצתו על, *Perush 'al ha-Torah / sh-ḥiber he-ḥakham ha-shalem Rabi Avraham Saba ' ve-kara shemo Tseror ha-mor; meysad al peshat ha-Torah u-ketsato al derekh ha-nistar u-ma'amre sefer ha-Zohar ve-kabalah ve-inyanim aḥerim mi-divre Razal* (Venice: Daniel Bomberg, 1522)
- Sahula, Isaac ben Solomon, זה ספר משל הקדמוני *Zeh sefer mashal ha-ḳadmoni* (Venice: Meir di Parenzo, 1550)
- Samegah, Joseph ben Benjamin, and Asher ben Jacob Parenzo, ספר מקראי קדש *Sefer Miḳrae ḳodesh: ... ḥaḳirot yeḳarot be-mitsvot ha-yir'ah v'eha-ahavah: Sod ve-ṭuv ṭa'ame mitsvot ha-mo'adim / asher ḥiber he-ḥakham ... Yosef Samigah; ve-hilko li-shene ḥalaḳim ... [Hutsa la-or] be-mitsvat ... Zoani [= Giovanni] Bragadin ben ... Alvize Bragadin; 'al yede ... Asher Porents* (Venice: Bragadin/Di Gara, 1586)
- Sarpi, Pauli, Paolo Servita, and Paulo Paradisus, *Pauli Paradiso Veneti Haebraicarum Litterarum Regii interpretis, de modo legendi Haebraice, dialogus* (Paris: Apud Hieronymum Gourmontium [Jerome Gourmont], 1534)
- Sasson, Abraham, קול מבושר *Kol mevašer: mefa'neḥ ne'lamim ve-gale razin de-ṭamirin be-mar'ot ish ḥamudot ... / Avraham Śašon* (Venice: Giovanni di Gara, 1605)
- Savasorda, Abraham bar Hiyya, *Sefer tsurat ha-erets ve-tavnit / kitsur ha-melekheth mispar asher hibber R. Eliya Mizrahi*. (Basileae: per Henrichum Petrum, 1546)
- Shem Tov, Shem Tov ibn, *Sefer haEmunot* (Ferrara: Usque, 1556)
- Shim'on ha-Darshan, שמעון ... שחבר / ... כל עשרים וארבע ספרים ... *Yalkuṭ ha-Torah: ... ha-niḳra Shim'oni ve-hu midrash 'al kol 'esrim ve-arba sefarim* (Venice, 1566)
- Shimon, ha-Darshan, mi-Frankfort, *Yalkut ha-Torah: ha-nikra Shimoni .ve-hu midrash al kol esrim ve-arba sefarim* (Cracow: Isaac mi-Prostitz, 1595/6) also (Venice: 1566)

- Solomon, Gershon ben, ספר שער השמים *Sefer Sha'ar ha-shamayim: pihu pataḥ be-ḥokhmah ya-yedaber 'al ha-'of* [ye-'al ha-behemah ... ye-'al ha-harim ye-'al sheleg u-barad] / Gershon ben Shelomoh (Venice: Meir di Parenzo, 1547)
- Soresina, Ya'akov, *Seder Hanikur* (Venice: Giovanni Di Gara, 1595)
- Stennett, Jehudah, *Dikduk Mikhlol, or a Comprehensive Grammar containing the most necessary Rules for the Reading and Attaining the Hebrew Tongue* (London: S. Roycroft, 1685)
- Steuchus, Augustinus Bishop of Cisamus, *Recognitio Veteris Testamenti ad Hebraicam veritatem, collata etiam editione Septuaginta interprete cum ipsa veritate Hebraica, nostra q; translatione, cum expositione Hebræorum ac Græcorum, qui passim toto opere citantur, etc* (Venetiis: Aldus Manutius, 1529)
- Tam, Jacob ben Meir, ספר הישר *Sefer ha-yashar* (Venice: Giovanni di Farri, 1544)
- Thomassin, Louis Pretre de l'Oratoire, Nicolas Barat, and Charles Oratorian Bordes, *Glossarium Universale Hebraicum*, etc. [Edited by C. Bordes and N. Barat.] (Paris: Imprimerie Royale, 1697)
- Tissard, F., *Alphabetum Hebraicum at Græcum*. [Consisting of a Hebrew Alphabet and a short Greek Grammar with exercises in Greek and Latin. By F. Tissard?] (Paris: Gilles de Gourmont, 1515)
- Tory, Geoffroy, *Champ Fleury. Auquel est contenu Lart & Science de la deue & vraye Proportiō des Lettres Attiques, quō dit autremēt Lettres Antiques, & vulgairement Lettres Romaines proportionees selon le Corps & Visage humaim*,. (Paris: Geofroy Tory and Giles Gourmont, 1529)
- Tremellius, Immanuel and Franciscus Junius, *Psalmi Davidis ex hebraeo* (Londini: Excudebat Henricus Middletonus impensis W.N., 1580)
- Calvin, Jean, Immanuel Tremellius, and Johannes Drusius, הנוח *Hinukh = Hoc est Catechesis : Sive Prima Institutio Avt Rvdimenta Religionis Christianæ, Ebraicæ, Græcæ, & Latinæ explicatæ* (Lvgdvnī Batavorvm = [Leiden] : Ex Officina Plantiniana, Apud Franciscum Raphelengium, 1591)
- Calvin, Jean and Immanuel Tremellius, *Sefer Hinukh behire Yah...* (Geneva: Robert I Estienne, 1554)
- Treves, Abraham ben Solomon, *Sefer Birkat Avraham ...al...birkat netilat yadayim* (Vinitsiah: Alviza Bragadon, 1552)
- Tudela, Benjamin of, מסעות של רבי בנימין *Masa'ot shel Rabi Binyamin* (Ferrara: A. Usque, 1555/56)
 ——— מסעות של רבי בנימין *Massa'ot shel Rabi Binjamin / Die Reisen des Rabbi Benjamin* (Freiburg im Breisgau: Zifroni, 1583)
- Uceda, Samuel ben Isaac, *Midrash Shemu'el: ye-hu be'ur al Pirḳe avot / me ... Shemu'el di Uzedah* (Venice: Al yede Zuan di Garah im otivot ha-Bombergi, 1585)
- Uceda, Samuel ben Isaac, and Rashi, *Sefer Midrash Shemuel* [Nidpas shelishit] (Venice: Daniel Zanetti, 1600)
- Usque, Abraham, *Hamishah Humshe Torah: im Hamesh megilot va-Haftarot mi-kol ha-shanah* (Ferrara: Abraham Usque, 1554)
- Veltwyck, Gerard, *Shevile tohu: Itinera deserti: De Judaicis disciplinis et earum vanitate* (Venetiis: Dan. Bomberg., 1539)
- Vignal, Pierre, *Libellus Ruth cum Scholis Masorae* (Paris: Guillaume II Le Bé, 1609)
- Vitré, Antoine, *S'il est avantageux pour le public d'accorder aux libraires des continuations de privilèges, en l'état que les choses sont à présent dans la librairie?* (Paris: Antoine Vitré 1696)
- Waser, Kaspar and Masius, Andreas, *Institutio linguae syrae* (Leiden: Ex off. Plantiniana, F. Raphelengius, 1594)
- Wemmers, Jacobus, *Lexicon Æthiopicum: ... cum eiusdem linguæ institutionibus Grammat. et indice vocum latinarum* (Romae: Typis & impensis Sac. Congreg. de Propaganda Fide, 1638)
- Ya'akov ben Avraham, *Selihot* (Basel: Waldkirch?, 1600)
 ———, *Seder haTefilot keMinhag Ashkenazi* (Basel: Waldkirch, 1598)
- Zacuto, Abraham, *Sefer Yuchasin* (Cracow: Prostitz, 1580-1)
- Zarfati, Yosef, ספר יד יוסף *Sefer Yad Yosef: ... arba'ah o ḥamishah derushim ... be-khol parashah u-farashah ... / hekhino ye-gam hikro Yosef Tsarfati* (Venice: Pietro and Lorenzo Bragadin, 1616)
- Zerah, Menahem ben Aaron ibn, צדה לדרך *Tsedah Laderakh* (Ferrara: Avraham Usque, 1554)

Secondary sources

- 'Aaron Ben Moses Ben Asher', <<http://www.jewishencyclopedia.com/articles/2857-ben-asher>> [Accessed 07 July 2011]
- 'Aboab', <<http://www.jewishencyclopedia.com/articles/344-aboab>> [Accessed 14 March 2008]
- Aboab, Imanuel, and Ischak Lopes, *Nomologia o Discursos legales*. Segunda edicion. Coregida y emendada por ... Ischak Lopes. (Amsterdam, 1727)
- 'Abraham Ben Meir Ibn Ezra', <<http://www.jewishencyclopedia.com/articles/7985-ibn-ezra-abraham-ben-meir-aben-ezra>> [Accessed 22 July 2011]
- Adhémar, Jean, Bibliothèque nationale, and Andre Linzeler, *Inventaire du fonds français. Graveurs du seizième siècle*. Vol. 2 tom. , (Paris, 1938)
- Adler, Cyrus, *The Jewish Encyclopedia*. 12 vols (New York and London: Funk & Wagnalls, 1907)
- Aishdas, 'Pamphlet 9 - The Letters of the Torah' (2002)<http://www.aishdas.org/toratemet/en_pamphlet9.html> [Accessed 28 July 2013]
- Alexenberg, Mel, 'Talmud Design and the Internet', in *What Was Old Is New Again: A Meeting of Art & Scholarship* (ZKM Center for Art & Media and Caeno Foundation, Karlsruhe, November 2008, 2010)
- Alibaux, Henri, *Les Premières Papeteries françaises* (Paris: Les Arts et le Livre, 1926)
- Amerbach, Johannes, and Barbara C. Halporn, *The correspondence of Johann Amerbach: early printing in its social context, Recentiores: later Latin texts and contexts*. (Ann Arbor: University of Michigan Press, 2000)
- Amert, Kay, and Robert Bringhurst, *The scythe and the rabbit : Simon de Colines and the culture of the book in Renaissance Paris* (Rochester, New York: Cary Graphic Arts Press, 2012)
- Amram, David Werner, *The makers of Hebrew books in Italy: being chapters in the history of the Hebrew printing press* (London: Holland Press, 1963)
- 'Anciens jeux: a Propos d'un livre rare Intitulé', *Le Magasin Pittoresque*, XV (1847), 67-70
- André, Jacques, and Michel Goossens, 'Codage des Caractères et Multi-Linguisme: de L'ASCII à Unicode et ISO/IEC-106', *Cahiers GUTenberg*, 20 (1995), 1-53.
- Armstrong, Elizabeth, *Robert Estienne royal printer: an historical study of the elder Stephanus* (Sutton Courtney: The Sutton Courtney Press, 1986)
- , *Robert Estienne: Royal Printer* (Cambridge: Cambridge University Press, 1954)
- Ascarelli, Fernanda, and Marco Menato, *La tipografia del '500 in Italia* (Firenze: Olschki, 1989)
- Assemblée Nationale, 'Ordonnance d'août 1539 ou « ordonnance de Villers-Cotterêts » prise par le Roi François Ier' <<http://www.assemblee-nationale.fr/histoire/villers-cotterets.asp>> [Accessed 26 September 2013]
- Audin, Marius, *Les livrets typographiques des fonderies françaises créées avant 1800: Etude historique et bibliographique* (Amsterdam: Gerard Th. van Heusden, 1964)
- Audisio, Gabriel, and Isabelle Rambaud, *Lire le français d'hier: manuel de paléographie moderne, XVe-XVIIIe siècle*. Quatrième édition (Paris: A. Colin, 2008)
- Bar-Ilan University Responsa Database', Bar-Ilan University, (<<http://www.biu.ac.il/jh/Responsa/>> [Accessed 14.10.2013]
- Bar Ilan University, 'Global Jewish Database (the Responsa Project)', Bar Ilan University, (2011)<<http://www.biu.ac.il/jh/Responsa/>> [Accessed
- Barbaro, Marco *Arbori de' patritii Veneti* (Venice: Archivio di Stato, 1743)
- Baruchson-Arbib, Shifra, *La culture livresque des juifs d'Italie à la fin de la Renaissance* (Paris: CNRS - Centre National de la Recherche Scientifique 2001)
- Bauer, Friedrich, *Handbuch fuer Schriftsetzer ... Dritte neu bearbeitete Auflage, etc* (Frankfurt am Main: Verlag von Klimesch & Co., 1910)
- Bayle, Pierre, and Prosper Marchand, *Dictionnaire historique et critique* (Amsterdam, Leiden, 1730)
- Beinert, Wolfgang, 'Fraktur' (2013)<<http://www.typolexikon.de/f/fraktur.html>> [Accessed 29 May 2010]
- Beit-Arié, Malachi, 'The codicological Data-Base of the Hebrew Palaeography Project: A Tool for Localizing and dating Hebrew Medieval Manuscripts', in *Hebrew studies: papers presented at a colloquium on resources for Hebraica in Europe held at the School of Oriental and African Studies University of London 11-13 September 1989*, ed. by Rowland-Smith, Diana and P. Sh. Salinger (London: British Library, 1991)
- , *Hebrew Codicology: tentative typology of technical practices employed in Hebrew dated manuscripts* (Jerusalem: The Israel Academy of Sciences and Humanities, 1981)

- , *The makings of the medieval Hebrew book: studies in palaeography and codicology* (Jerusalem: Magnes Press, Hebrew University, 1993)
- , 'The relationship between Hebrew Printing and handwritten Books: Attachment or Detachment', in *The Makings of the Medieval Hebrew Book*, ed. by Beit-Arié, Malachi (Jerusalem: The Magnes Press, 1993), pp. 251-277
- Beit-Arié, Malachi, Colette Sirat, and Mordechai Glatzer, *Codices Hebraicis litteris exarati quo tempore scripti fuerint exhibentes = Otsar ha-mitshafim ha-'ivriyim: kitve-yad bi- khetav 'ivri mi-yeme ha-benayim be-tsiyune ta'arikh. Tome IV, De 1144 à 1200* (Turnhout: Brepols, 2006)
- Bell, Dean Phillip, and Stephen G. Burnett, *Jews, Judaism, and the Reformation in sixteenth-century Germany, Studies in Central European histories ; 37.* (Leiden: Brill, 2006)
- Bernard, Auguste, *Geofroy Tory, peintre et graveur, premier imprimeur royal, reformateur de l'orthographe et de la typographie sous Francois Ier* (Paris: Edwin Tross, 1857)
- Bernheimer, Carlo, *Paleografia ebraica* (Firenze: L.S. Olschki, 1924)
- Bernoni, Domenico, *Dei Torresani, Blado e Ragazzoni: celebri stampatori a Venezia e Roma nel XV e XVI secolo, cogli elenchi annotati delle rispettive edizioni* (Farnborough: [Germany Printed], 1968)
- Bernstein, Jane A., *Print Culture and Music in Sixteenth-Century Venice* (New York: Oxford University Press, 2002)
- Berty, Adolphe, *Topographie historique du Vieux Paris. Région centrale de l'Université ... Extrait du Grand Plan d'Adolphe Berty* (Paris: Imprimerie Nationale, 1897)
- Bèze, Théodore de , Francois the elder Du Jon, and Joannes Immanuel Tremellius, *Testamenti Veteris Biblia sacra, sive, libri canonici ... Latini ... facti ... ab Immanuele Tremellio & Francisco Junio. Accesserunt libri qui vulgo dicuntur Apocryphi, Latine redditi ... a F. Junio ... Quibus etiam adjunximus Novi Testamenti libros ex sermone Syro ab eodem Tremellio, & ex Græco a Theodoro Beza in Latinum versos ... Secunda cura F. Junii. Vol. 6 pt.* (Genevæ: apud I. Tornæsium: Genevæ; impensis A. Wecheli hæredum, C. Marnii & I. Aubrii: Francofurdi,, 1590)
- Biblioteca Nazionale Centrale Vittorio, Emanuele, Giacomo Belli, Antonio Asolano Blado, Giuseppe Fumagalli, Belli, and Emerenziana Vaccaro-Sofia, *Catalogo delle edizioni romane di Antonio Blado Asolano ed eredi, 1516-1593, possedute dalla Biblioteca Nazionale Centrale Vittorio Emanuele di Roma ... Compilato da Giuseppe Fumagalli ... e Giacomo Belli, etc. (fasc. 3. Compilato da Emerenziana Vaccaro-Sofia.)*3 fasc. pp. 311. Roma, 1891, 1942)
- Bibliothèque nationale, Etienne Anisson-Duperron, and Ernest Coyecque, *Inventaire de la Collection Anisson sur l'histoire de l'imprimerie et la librairie, principalement a Paris [formed principally by J. d'Hemery] ... Par E. Coyecque* (Paris, 1900)
- Bibliothèque nationale, Pierre Jean Boudot, Anicet Melot, and Claude Sallier, *Catalogue des livres imprimez de la Bibliothèque du Roy* (Paris: Imprimerie Nationale, 1750)
- Bigmore, E. C., and C. W. H. Wyman, *A bibliography of printing: with notes and illustrations* (New Castle, Del. ; London: Oak Knoll & the British Library, 2001)
- Binding, Paul, *Imagined corners: exploring the world's first atlas* (London: Review, 2003)
- Birnbaum, Solomon A., *The Hebrew scripts* (London: Palaeographia, 1971)
- Blau, Ludwig 'The Extraordinary Points in the Pentateuch: The Ten Nequdoth of the Torah, or the Meaning and Purpose of the Extraordinary Points of the Pentateuch (Massoretic Text) by Romain Butin', *The Jewish Quarterly Review*, 19 (1907), 411-419
- Bloch, Joshua, 'Venetian Printers of Hebrew Books', *Bulletin of the New York Public Library*, 36 (1932), 71-81
- Bobichon, Philippe, *Le lexicon: Mise en page et mise en texte des manuscrits hébreux, grecs, latins, romans et arabes. Vol. CNRS: UPR841* (Paris: Institut de recherche et d'histoire des textes (IRHT), 2009)
- Bolton, Claire, 'The 15th-Century Printing Practices of Johann Zainer, Ulm, 1473-1478', University of Reading, 2008)
- Bomberghen, Henri van, *Généalogie de la famille van Bomberghen* (Bruxelles, 1914)
- Bonfil, Robert, *Jewish life in Renaissance Italy* (Berkeley: University of California Press, 1994)
- Boorman, Stanley 'Printing and publishing of music' (2011)<<http://www.oxfordmusiconline.com.catalogue.ulrls.lon.ac.uk/subscriber/article/grove/music/40101pg1#S40101.1>> [Accessed 6 November 2013]

- Borsa, Gedeon, 'Drucker und Verleger in Italien vor 1601 und ihre Ortschaften', in *La Stampa in Italia nel Cinquecento: atti del convegno, Roma, 17-21 ott. 1989*, ed. by Santoro, Marco (Roma: Bulzoni, 1992), pp. 135–167
- Boudot, P. J., and C. Sallie, *Catalogue des livres imprimez de la Bibliothèque du Roy (Belles Lettres)* (Paris: Bibliothèque nationale (France). Département des imprimés, 1750)
- Bouillart, Jacques, *Histoire de l'abbaye royale de Saint Germain des Prez. Contenant la vie des abbez qui l'ont gouvernée depuis sa fondation: les hommes illustrés qu'elle a donnez a l'Eglise et a l'Etat: les privileges accordez par les souverains pontifes ... Le tout justifié par des titres authentiques, & enrichi de plans & de figures* (Paris, 1724)
- Boutier, Jean, Jean Noel Jeanneney, Jean-Yves Sarazin, and Marine Sibille, *Les plans de Paris des origines, 1493, à la fin du XVIIIe siècle: étude, carto-bibliographie et catalogue collectif* (Paris: Bibliothèque nationale de France, 2002)
- Boutiot, Theophile, Henry Boutiot, and Alexis Silvetre Det, *Histoire de la ville de Troyes et de la Champagne méridionale* (Troyes and Paris: Auguste Aubry and Dufey-Robert, 1870)
- Braudel, Fernand, and Sian Reynolds, *The Mediterranean and the Mediterranean world in the age of Philip II* (London: Fontana Press, 1973)
- Briailles, Comte Chandon de, 'Le Fichier Chandon' (2004) <http://www.archives-aube.com/arkotheque/fonds_chandon/index.php> [Accessed 8 April 2013]
- Briquet, Charles, *Les Filigranes. Dictionnaire historique des marques du papier des leur apparition vers 1282 jusqu'en 1600* (Paris, Geneva: Alphonse Picard et fils, 1907)
- British Museum Dept. of Printed Books, A. F. Johnson, and Victor Scholderer, *Short-title catalogue of books printed in Italy and of Italian books printed in other countries from 1465 to 1600 now in the British museum* ([S.l.]: British museum, 1958)
- Broggiotti, Andrea, and Hendrik D. L. Vervliet, *The type specimen of the Vatican Press 1628* (Amsterdam: Menno Hertzberger, 1967)
- Broughton, Hugh, *An epistle of an ebrew willinge to learne Christianity sent by him to London: & thence, by the Archb. of Canterburies aduise, to Basil: thence returned vuith [sic] some further spech vpon it vnto the Quene of Englandes most excellent maiesty* (Basel: Connadus Waldkirch, 1598)
- , *Epistolae variae et variarum linguarum, de Byzantiacis hebraeis, discupientibus erudiri in Christi D. Sacro volumine, atque adeo de alio magno viro, quem nisi obliquè significare, Byzantij saltem non oportet, in re adhuc dubiâ. Argumenum docebit susius sequens pagina* (Basileae apud Conradum Waldkirch, 1599)
- Brown, Horatio, *The Venetian printing press* (London: John C. Nimmo, 1891)
- Brown, Michelle, *A guide to western historical scripts from antiquity to 1600* (London: British Library, 1990)
- Brown, Michelle, and Patricia Lovett, *The historical source book for scribes* (London: British Library, 1999)
- Budé, Eugene de, *Vie de Guillaume Bude fondateur du collège de France (1467-1540)* (Paris: Librairie Académique Didier Emile Perrin, Libraire-Editeur, 1884)
- Burnett, Stephen G., *Christian Hebraism in the Reformation era (1500-1660): authors, books, and the transmission of Jewish learning, Library of the written word*, (Leiden: Brill, 2012)
- , 'Christian Hebrew printing in the 16th century: Printers, Humanism and the impact of the Reformation', *Helmantica*, 51 (2000), 13-42
- Burnhill, Peter, *Type spaces: in-house norms in the typography of Aldus Manutius* (London: Hyphen Press, 2003)
- Bush, George, *A Grammar of the Hebrew Language* (New York: Gould, Newman & Saxton 1839)
- Cahane, Rabbi Ts., *Likut Sifrei Stam (the scribes' handbook)* (Jerusalem: Machon Daat Yosef, 1998)
- Calimani, Riccardo, *The Ghetto of Venice* (Milano: Arnoldo Mondadori, 1995)
- Campbell, Katia, 'Notes sur l'hébreu de Rabelais: La rencontre avec Panurge (Pantagruel, chap. 9)', *Etudes Rabelaisiennes*, XXV (1991), 95-105
- , 'Rabelais and the Massorah', in *Rabelais in context : proceedings of the 1991 Vanderbilt Conference*, ed. by Bowen, Barbara Cherry (Birmingham, Ala.: Summa Pub., 1993), pp. 55-66
- Capelli, Adriano, *Cronologio Cronografia e Calendario Perpetuo* (Milano: Editore Ulrico Hoepli, 1983)
- Carter, Harry, *Essai de fonte dans les matrices conservées au Musée Plantin-Moretus* (Oxford Printed for private circulation at the University Press 1954)
- , 'Making a Printing-Type', *Palestine Post*, December 14 1945
- , 'A Message from Plantin to Guillaume Le Bé', *De Gulden Passer*, 36 (1958), 59-62

- , *Notes towards a specimen of the Ancient Typographical Materials principally collected and bequeathed to the University of Oxford, Fascicule IV: Exotic Types* (Oxford: Printed privately, 1957)
- , 'Plantin's types and their Makers', *De Gulden Passer*, 34 (1956), 121-143
- , 'Review of Die Basler Hebraeischen Drucke (1492-1866)', *The Library*, S5-XX1 (1966), 337-340
- , *Specimen types from the matrices at the Plantin-Moretus Museum, cast by H.G.C. 1954* (Oxford: University Press, 1955)
- , *A view of early typography up to about 1600, (Lyell lectures, 1968)* (Oxford: Clarendon Press, 1969)
- Casaubon, Isaac, and Theodoor Jansson van Almelooven, *Isaaci Casauboni Epistolæ* (Roterodami: Typis Casparis Fritsch et Michaelis Böhm, 1709)
- Casper, Bernard, *An introduction to Jewish Bible Commentary* (New York and London: Thomas Yoselof, 1960)
- Catalogue des Actes de François Ier 1515-1547*. Gallica.fr (Paris: Imprimerie Nationale, 1905)
- Cattin, Paul, *Les Ecritures Anciennes: Paléographie Française et Histoire XVIe-XVIIIe siècles* (Bourg-en-Bresse: Les Amis des Archives de l'Ain, 1987)
- Chaunu, Pierre 'Mourir à Paris (XVIe-XVIIe-XVIIIe siècles)', *Annales. Économies, Sociétés, Civilisations*, 31e année (1976), 29-50
- Chauvet, Paul, *Les ouvriers du livre en France: des origines à la Révolution de 1789*. [1. *d.] (Paris: Presses universitaires de France, 1959)
- Clair, Colin, *Christopher Plantin* (London: Cassell, 1960)
- Clenardus, Nicolaus, and Alphonse Roersch, *Correspondance de Nicolas Clénard. Publiée par Alphonse Roersch. Lat. & Fr* (Bruxelles: Palais des Académies, 1940)
- Coakley, J. F., *The typography of Syriac: a historical catalogue of printing types, 1537-1958* (London: British Library, 2006)
- Coakley, J.F., *The Hebrew Types of the Jericho Press* (Ely, 2010)
- Cole, Bruce, *The Renaissance artist at work : from Pisano to Titian* (London: John Murray, 1983)
- Contat, Nicolas, and Giles Barber, *Anecdotes Typographiques* (Oxford: Oxford Bibliographical Society, 1980)
- Cooperman, Bernard, *Organizing Knowledge for the Jewish market: An editor/printer in Sixteenth-century Rome* (Washington, D.C.: The Library of Congress)
- , 'Organizing Knowledge for the Jewish market: An editor/printer in Sixteenth-century Rome', in *Perspectives on the Hebraic book: the Myron M. Weinstein memorial lectures at the Library of Congress*, ed. by Weinstein, Myron M. and Peggy K. Pearlstein (Washington, D.C.: Library of Congress, 2012), p. 240 p.
- 'cote', <<http://www.larousse.fr/dictionnaires/francais/cote/19600>> [Accessed 6 November 2013]
- Cotgrave, Randle, *A Dictionarie of the French and English tongues* (London: Adam Islip, 1611)
- Couperie, Pierre, and Madeleine Jurgens, 'Le logement à Paris au XVIe et XVIIe siècles', *Annales. Économies, Sociétés, Civilisations*, 17e année (1962), 488-500.
- Cousin, Jean, *La vraye science de la pourtraicture descrite et démontrée* (Paris: Guillaume Le Bé, 1671)
- Coyecque, Ernest Louis, *Recueil d'actes notariés relatifs à l'histoire de Paris et de ses environs au XVIe siècle. 1, 1498-1545. 2, 1532-1555, Histoire générale de Paris*. (Paris: Imprimerie nationale, 1905)
- Da Mosto, Andrea, *L'Archivio di Stato di Venezia: Indice Generale, Storico, Descrittivo ed Analitico* (Roma: Biblioteca d'Arte Editrice, 1937)
- 'Dagesh', <<http://www.jewishencyclopedia.com/articles/4844-dagesh>> [Accessed 23 June 2011]
- Davies, Martin, *Aldus Manutius: printer and publisher of Renaissance Venice* (London: The British Library, 1995)
- de Berthier, Frédéric, *Les Anciennes familles de Troyes* (Neuilly-sur-Seine: Collection Monte Cristo, 2006)
- de L'Espinasse, René, Etienne Boileau, and François Bonnardot, *Les métiers et corporations de la ville de Paris, Histoire générale de Paris*. (Paris: Imprimerie nationale, 1879)
- De Rossi, Giovanni Bernardo, *Annales Hebraeo-typographici sec. XV* (Parmae, 1795)
- , *Annali Ebreo-tipografici di Cremona* (Parma: Stamperia Imperiale, 1808)
- Deberny et Peignot, *Caractères étrangers / fonderies Deberny et Peignot*. Vol. Fascicule 1 (Hébreu) (Paris: Deberny et Peignot, 1924)

- Delacolonge, Louis, and Harry Carter, *The type specimen of Delacolonge. Les caractères et les vignettes de la fonderie du sieur Delacolonge, Lyons, 1773. Introduction and notes by Harry Carter. (Facsimile ... made from a copy belonging to the publishers.)* (Amsterdam: Van Gendt & Co, 1969)
- Deprouw, Stéphanie, and Musée national de la Renaissance (France), *Geoffroy Tory: imprimeur de François Ier, graphiste avant la lettre* (Paris: Réunion des musées nationaux: Grand Palais, 2011)
- Derenbourg, J., 'L'Édition de la Bible Rabbinique de Jean Buxtorf', *Revue des Etudes Juives*, 30 (1895), 70-78
- , 'Manuel du Lecteur', *Journal Asiatique*, XV (Sixième série) (1870), 309-550
- DeVenne, Theodore Low, *The Invention of Printing. A collection of facts and opinions descriptive of early prints and playing cards, the block-books of the fifteenth century, the legend of Lourens Janszoon Coster ... and the work of John Gutenberg and his associates. Illustrated with facsimiles of early types and wood-cuts* (New York: Francis Hart & Co., 1876)
- Dibdin, Thomas Frognall, *An introduction to the knowledge of rare and valuable editions of the Greek and Latin classics: Together with an account of polyglot Bibles, polyglot psalters, Hebrew Bibles, Greek Bibles and Greek fathers, and the Latin fathers.* 4th ed., greatly enlarged and corrected. ([S.l.]: Harding and Lepard, 1827)
- Diderot, Denis, and Jean-Baptiste le Rond D'Alembert, *L'Encyclopedie: Imprimerie-Relieure* (Paris: Bibliotheque de l'Image, 2001)
- Diefendorf, Barbara B., 'Les divisions religieuses dans les familles parisiennes avant la Saint-Barthélémy', *Histoire, économie et société*, 7 (1988), 55-77
- Douen, Emmanuel, and Clément Marot, *Clément Marot et le Psautier Huguenot, étude historique, littéraire, musicale et bibliographique, contenant les mélodies primitives des Psaumes et des spécimens d'harmonie, etc* (Paris: L'Imprimerie Nationale, 1878)
- Dreyfus, John, *Type Specimen Facsimiles II Nos 16-18* ([S.l.]: University of Toronto Press, 1972)
- Dreyfus, John, Harry Carter, Alfred Johnson, Stanley Morison, and Hendrik D.L. Vervliet, *Type specimen facsimiles 1-15* (London: Bowes & Bowes; Putnam, 1963)
- Drury, J. Linda, 'Inventories in the Probate Records of the Diocese of Durham', *Archaeologia Aeliana*, 5th series, 28 (2000) (2000)
- Du Jon, Francois the elder, and Joannes Immanuel Tremellius, *Bibliorum pars tertia, id est, quinque libri Moschis. (Pars secunda, id est, libri historici, etc.-Pars tertia, id est, quinque libri poetici, etc.-Pars quarta, id est, prophetici libri omnes, numero xvi., etc.) Latini recens ex Hebræo facti, brevisque scholiis illustrati, ab Immanuele Tremellio & Francisco Iunio. (Libri Apocryphi, sive appendix Testamenti Veteris ... latina ... facta, & notis brevis illustrata per F. Iunium.)* (Francofurti ad Moenum: A. Wechelus: , 1579)
- Du Vair, Guillaume Bishop of Lisieux, Jacques Flach, and Frantz Funck-Brentano, *Traité de la constance et consolation es calamitez publiques ... Edité par Jacques Flach ... et F. Funck-Brentano, etc* (Paris: Librairie de la Société de Recueil Sirey, 1915)
- Duggan, Mary Kay, *Italian music incunabula: printers and type* (Berkeley: University of California Press, 1992)
- , 'Italian music incunabula: printers and typefaces' (PhD, University of California, 1981)
- , 'A System for Describing Fifteenth-Century Music Type', *Gutenberg-Jahrbuch* (1984), 67-76
- Ernesti, Johann Heinrich Gottfried, and Erhard Reusch, *Die Wol-eingerichtete Buchdruckerey, mit hundert und ein und zwanzig Teutsch- Lateinisch- Griechisch- und Hebräischen Schrifften, vieler fremden Sprachen Alphabeten, musicalischen Noten, Calender-Zeichen, und Medicinischen Characteren, ingeleichen allen üblichen Formaten bestellet, und mit accurater Abbildung derr Erfinder der löblichen Kunst, nebst einer summarischen Nachricht von den Buchdruckern in Nürnberg, ausgezieret. Am Ende sind etliche kurz-gefasste Anmerkungen von der Hebräischen Sprach angefüget* (Nürnberg: Johann Andrea Endters seel. Sohn und Erben, 1733)
- Essling, Prince d', Victor, 'Archivio di Stato di Venezia ("Archivietto")', Stampatori, Ricerca Duca di Rivoli', (Venice: Archivio di Stato Venezia, 1901-1904)
- Fertel, Martin Dominique, *La science pratique de l'imprimerie. Contenant des instructions très-faciles pour se perfectionner dans cet art. On y trouvera une description de toutes les pieces dont une presse est construite ... avec une methode ... pour imposer toutes sortes d'impositions, etc* (Saint Omer, 1723)

- Fétis, François-Joseph, and Arthur Pougin, *Biographie universelle des Musiciens, et Bibliographie générale de la Musique* (Paris: Librairie de Firmin Didot Frères, Fils et Co., 1860)
- Fortis, Umberto, *Il Ghetto sulla Laguna* (Venezia: Storti Edizioni, 1987)
- Fossey, Charles, *Notices sur les caractères étrangers anciens et modernes rédigées par un groupe de savants. Réunies par M. C. Fossey* (Paris: Imprimerie Nationale, 1927)
- Fouché, Pascal, Daniel Péchoin, and Philippe Schuwer, *Dictionnaire encyclopédique du livre. Volume 2, E-M* (Paris: Cercle de la librairie, 2005)
- Fournier, Jean-Pierre, and Stanley Morison, *L'Inventaire de la Fonderie Le Bé. Selon la transcription de Jean Pierre Fournier*. [Edited, with an introduction, by Stanley Morison.] (Paris: Documents Typographiques Français, 1957)
- Fournier, Pierre-Simon, 'Manuel Typographique Tome I' (1764) <<http://jacques-andre.fr/ed/index.html#fournier>> [Accessed 6 November 2013]
- Fournier, Pierre-Simon 'Manuel Typographique' 1764) <<http://jacques-andre.fr/ed/FournierI-E.pdf>> Tome I] 08 July 2011
- Fournier, Pierre-Simon, and Jacques André, 'Lettres polémiques sur la typographie' (2009) <<http://jacques-andre.fr/ed/Lettres.pdf>> [Accessed 07 July 2011]
- Fournier, Pierre-Simon (le Jeune), *Traité historique et critique sur l'Origine et le progres des caracteres de fonte pour l'impression de la musique* (Paris et Berne: Chez Barbou, 1765)
- Fournier, Pierre Simon, and Harry Carter, *Fournier on Typefounding*. ed. by Carter, Harry (London: Soncino Press, 1930)
- Frank, Raphael, *Über Hebräische Typen und Schiftarten* (Berlin: Schriftgiesserei H. Berthold Abt. Privatdrucke, 1926)
- Freimann, A., 'Die Hebräischen Inkunabeln der Druckereien in Spanien und Portugal', *Gutenberg-Jahrbuch* (1925), 203-206
- Freimann, Aron, and Moses Marx, *Thesaurus typographiae Hebraicae saeculi XV = Hebrew printing during the fifteenth century (Ha-Qtsar li-melekhet ha-defus ha-ivri ha-rishonah ad shenat r"s)* (Jerusalem: The Universitas Booksellers, 1969)
- 'French Wars of Religion – a quick timeline', <<http://jimmcneill.wordpress.com/2011/04/09/french-wars-of-religion-a-quick-timeline/>> [Accessed 16 July 2011]
- Friedberg, Bernhard, *Toldot ha-defus ha-Ivri be-Polanyah: me-reshit hivasdo bi-shenat 294 ve-hitpathauto ve ad zemanenu (History of Hebrew Typography in Poland)* (Tel-Aviv, 1950)
- Friedlaender, Henri, *Die Entstehung meiner Hadassah-Hebräisch* (Hamburg: Kurt Christians und Richard von Sichowsky, 1967)
- Fuks, L., and R. G. Fuks-Mansfeld, *Hebrew typography in the Northern Netherlands, 1585-1815* (Leiden: Brill, 1984)
- Gando, Nicolas, and Pierre François Gando, *Observations sur le traité historique et critique de M. Fournier le Jeune* (Berne and Paris: Chez Moreau, Libraire-Imprimeur, 1762)
- Gaskell, Philip, 'A nomenclature for the Letter-forms of Roman Type', *The Library: The Transactions of the Bibliographical Society*, XXIX (1974), 42-51
- Gesenius, Wilhelm, E. Kautsch, and A. E. Cowley, *Gesenius' Hebrew grammar* (Oxford: Clarendon Press, 1910)
- Gessner, Christian Friedrich, Johann Depositio Rist, Heinrich August Wildenhayn, and Caspar Schreiber, *Der in der Buchdruckerei wohl unterrichtete Lehr-Junge; oder: Bey der löblichen Buchdruckerkunst nöthige und nueliche Anfangsgründe* (Leipzig, 1743)
- Gilmont, Jean-François, 'Les Centres de la Production Imprimée', in *Produzione e commercio della carta e del libro secc. XIII-XVIII: atti della "Ventitreesima Settimana di studi" 15-20-aprile 1991 - Atti delle "settimane di studi" e altri convegni. Serie II ; 23.*, ed. by Istituto internazionale di storia economica F. Datini. Settimana di studi (23rd :1991: Prato Italy) and Simonetta Cavaciocchi (Firenze: Le Monnier, 1992), pp. 343-364
- Ginsburg, Christian D., *Introduction to the Massoretico-critical edition of the Hebrew Bible* (New York: Ktav Publishing House, 1966)
- Glaister, Geoffrey, and Donald Farren, *Encyclopedia of the book* (New Castle, Del.: Oak Knoll Press; London: British Library, 1996)
- 'Glossaire de termes typographiques', <<http://www.adobe.com/fr/type/topics/glossary.html>> [Accessed 03 July 2011]
- Goldstein, David, Joel ben Simeon, and Eleazar ben Judah of Worms, *The Ashkenazi Haggadah: a Hebrew manuscript of the mid-15th century from the collections of the British Library*. New ed. (London: Thames and Hudson, 1997)

- Grafton, Anthony, *The Culture of Correction in Renaissance Europe* (London: The British Library, 2011)
- , *The culture of correction in Renaissance Europe* (London: British Library, 2011)
- Grafton, Anthony, and Joanna Weinberg, *'I have always loved the holy tongue': Isaac Casaubon, the Jews, and a forgotten chapter in Renaissance scholarship* (Cambridge, Mass. ; London: Belknap, 2011)
- Gramigna, Silvia, Annalisa Perissa Torrini, and Roberto Lazzari, *Scuole grandi e piccole a Venezia tra arte e storia: confraternite di mestieri e devozione in sei itinerari* (Italy: s.n., 2008)
- Grosley, P.J., *Ephemerides* (Paris: Chez Durand et Brunot-Labbe, 1811)
- Guignes, Joseph de, *Principes de composition typographique pour diriger un compositeur dans l'usage des caractères orientaux de l'imprimerie royale.*, 1790)
- Guilleminot-Chrétien, Geneviève, 'Le Testament de Claude Garamont', in *Le livre et l'historien: Etudes offertes en l'honneur du Professeur Henri-Jean Martin*, ed. by Martin, Henri Jean and Frederic Barbier (Geneve: Librairie Droz, 1997), pp. 133-139
- Guillo, Laurent, 'La bibliothèque de musique des Ballard d'après l'inventaire de 1750 et les notes de Sébastien de Brossard', *Revue de musicologie*, 90/2 (2004), 195-232
- , *Pierre I Ballard et Robert III Ballard, imprimeurs du roy pour la musique (1599-1673)* (Sprimont and Versailles: Éditeur Pierre Mardaga and Centre de Musique Baroque de Versailles, 2003)
- , 'Problèmes généraux d'édition musicale', in *Le concert des voix et des instruments à la Renaissance: actes du XXXIVe colloque international d'Etudes humanistes (Tours, CESR, 1-11 juillet 1991)* (Paris: CNRS, 1995), pp. 105-119
- Habermann, Avraham Meir, *HaMadpis Cornelio Adel Kind u-Beno Daniel (In Hebrew)* (Jerusalem: Rubin Mass, 1980)
- , *HaMadpis Daniel Bombergi veReshimat Sefri Beit Defuso (The Printer Daniel Bomberg and a list of books published by his press)* (Zefat: Museum of Printing Art in Zefat, 1978)
- Haebler, Conrad, 'Typefounding and Commerce in Type during the early Years of Printing', *Ars Typographica*, III (1926), 3-35
- 'Hai Ben Sherira', <<http://www.jewishencyclopedia.com/articles/7051-hai-ben-sherira>> [Accessed 08 July 2011]
- Hai ben, Sherira, Jean Mercier, and Jehoseph ben Hanan ben Nathan Ezobi, *Shire musar haSechel* (Parisiis, 1559)
- Haiman, György, and Elizabeth Soltész, *Nicholas Kis: a Hungarian punch-cutter and printer 1650-1702* (San Francisco: Jack W. Stauffacher, 1983)
- Hamilton, Alastair, *William Bedwell the Arabist, 1563-1632* (Leiden: Published for the Sir Thomas Browne Institute by E J Brill, 1985)
- Handover, P.S., *Printing in London, from 1476 to modern times. Competitive practice and technical invention in the trade of book and Bible printing, periodical production, jobbing, &c. [With facsimiles.]* (London: George Allen & Unwin, 1960)
- Haralambous, Yannis, 'Typesetting the Holy Bible in Hebrew, with TEX' (1994)<<https://www.tug.org/TUGboat/tb15-3/tb44haralambous-hebrew.pdf>> [Accessed 6 November 2013]
- Harris, Neal, 'Analytical bibliography: an alternative prospectus' (2004)<<http://ihl.enssib.fr/siteihl.php?page=55>> [Accessed 8 April 2013]
- Harris, Neil, 'A mysterious UFO in the Venetian 'Dama Rovenza' [c. 1482]', *Gutenberg-Jahrbuch*, 78 (2003), 22-30
- Hauser, H., *Ouvriers du Temps Passé* (Paris: Félix Alcan, Editeur, 1906)
- 'Hazakah', <<http://www.jewishencyclopedia.com/articles/7412-hazakah>> [Accessed 10 June 2011]
- Hebrew Range 0590–05FF, <<http://unicode.org/charts/PDF/U0590.pdf>> [Accessed 26 June 2011]
- Heller, Marvin J., 'Ambrosius Froben, Israel Zifroni and Hebrew Printing in Freiburg im Breisgau', *Gutenberg-Jahrbuch*, 80 (2005), 137-148
- , *The seventeenth century Hebrew book: an abridged thesaurus* (Leiden and Biggleswade: Brill and Extenza Turpin, 2011)
- , *The sixteenth century Hebrew book: an abridged thesaurus* (Leiden: Brill, 2004)
- Hellinga, Wytze Gerbens, Gerrit Willem Ovink, and D. A. S. Reid, *Copy and Print in the Netherlands. An atlas of historical bibliography ... With introductory essays by H. de la Fontaine Verwey and G. W. Ovink. (Translator, D. A. S. Reid.) [With plates.]* (Amsterdam: Federatie der Werkgeversorganisatiën in het Boekdrukkersbedrijf, 1962)

- Heuberger, Rachel, and Stadt- und Universitätsbibliothek Frankfurt am Main, *Hebräische Drucker und Drucker im Frankfurter Raum* (Frankfurt a. M.: Stadt- und Universitätsbibliothek Frankfurt am Main, 1994)
- Hiley, David, *Western plainchant: a handbook* (Oxford: Clarendon Press, 1993)
- Hiscox, Gardner Dexter, *Mechanical Movements, Powers, Devices and Appliances ... Eleventh edition, revised and enlarged* (London: Constable & Co., 1910)
- Hochuli, Jost, *Das Detail in der Typographie* (München/Berlin: Deutscher Kunst Verlag GmbH, 1990)
- Howe, Ellic, 'An Introduction to Hebrew Typography', *Signature*, 5 (1937), 12-29
- , 'The Le Bé Family: typefounders, printers, paper merchants, engravers, and writing masters, 1525-1730', *Signature* (1938)
- Howe, Ellic, and Marius Audin, 'French type specimen books', *The Library*, 6 (1951), 28-41
- Hutt, Allen, *Fournier, the compleat typographer* (London: Frederick Muller Ltd, 1972)
- Hyamson, Albert Montefiore and Silbermann, and Abraham Moritz Silbermann, *Vallentine's Jewish Encyclopaedia. Edited by Albert M. Hyamson and Dr. A. M. Silbermann. With maps, plans and numerous illustrations* (London: Shapiro, Vallentine & Co., 1938)
- Hyamson, Albert, and Abraham Silbermann, *Vallentine's Jewish Encyclopaedia* (London: Shapiro, Vallentine & Co., 1938)
- Imprimerie Royale, *Spécimens des types français et étrangers de l'Imprimerie Impériale, Mai 1855* (Paris: Imprimerie Imperiale, 1855)
- '*Incunabula*', <http://www.jewishvirtuallibrary.org/jsource/judaica/ejud_0002_0009_0_09521.html> [Accessed 4 October 2012]
- '*Inventory After Death (ET/XLV/161)*', <<http://www.geneanet.org/archives/actes/view/?idacte=131663&p=1>> [Accessed 6 November 2013]
- Isaac, Frank, *English Printers' Types of the Sixteenth Century* (Oxford and London: Oxford University Press and Humphrey Milford, 1936)
- Jeffery, L. H., *The local scripts of archaic Greece: a study of the origin of the Greek alphabet and its development from the eighth to the fifth centuries B.C* (Oxford: Clarendon, 1990)
- Johnson, A. F., *French sixteenth century printing, Periods of typography.* (London: E. Benn, 1928)
- , 'Some types used by Paolo Manuzio', *The Library*, s4-XIX (2) (1938)
- , 'The Supply of Types in the Sixteenth Century', *The Library: The Transactions of the Bibliographical Society*, s4 XXIV (1943), 47-65
- , *Type designs: their history and development.* 2nd ed. (London: Grafton, 1934)
- Johnson, J. W., *Typographia, or the printers instructor* ([S.l.]: [s.n.], 1824)
- Josserand, Pierre, and Jean Bruno, 'Les Estampilles du département des Imprimés de la Bibliothèque Nationale', in *Mélanges d'histoire du livre et des bibliothèques offerts à M. Frantz Calot* (Paris: Librairie d'Agences, 1960), pp. 261-298
- Jurgens, Madeleine, *Documents du Minutier central des notaires de Paris. Inventaires après décès* (Paris: Archives nationales, 1982)
- Kalman, Ruth, 'The Bookcraft of Daniel Bomberg's Press in Venice in the first Half of the 16th Century (In Hebrew)', Hebrew University of Jerusalem, 1992)
- Kapr, Albert, *Fraktur: Form und Geschichte der gebrochenen Schriften* (Mainz: Verlag Hermann Schmidt, 1993)
- Kapr, Albert, and Douglas Martin, *Johann Gutenberg: the man and his invention* (Aldershot ; Brookfield, Vt.: Scolar Press, 1996)
- Kaufmann, David, 'Die Verbrennung der Talmudischen Litteratur in der Republik Venedig', *The Jewish Quarterly Review*, 13 (1901), 533-538
- Kessler-Mesguich, Sophie, 'Early Christian Hebraists', in *Hebrew Bible*, ed. by Sæbø, Magne, C. Breklemans and Menahem Haran (Göttingen: Vandenhoeck & Ruprecht, 1996), pp. 254-275
- Kestenbaum & Company, '*Fine Judaica: Printed Books, Manuscripts, Autograph Letters, Graphic & Ceremonial Art To Be Auctioned On Thursday, January 31st*', ed. by Company, Kestenbaum & (New York: Kestenbaum & Company, 2013)
- Könnecke, Gustav *Hessisches Buchdruckerbuch enthaltend Nachweis aller bisher bekannt gewordenen Buchdruckereien* (Marburg in Hessen: N.G. Elwert, 1894)
- Kwakkel, Erik, 'A New Type of Book for a New Type of Reader: The Emergence of Paper in Vernacular Book Production', *The Library*, 4 (3) (2003), 219-248
- L'Estoile, Pierre de, and Philippe Papin, *Paris pendant les guerres de Religion: extraits de ses registres-journaux, Collection "Histoire"* (Paris: Arlea, 2007)

- L'Imprimerie Nationale, *Cabinet des poinçons de l'Imprimerie Nationale*. Vol. 2. Ed (Paris L'Imprimerie Nationale, 1950)
- , *Les caractères de l'Imprimerie Nationale* (Paris L'Imprimerie Nationale, 1990)
- 'La livre Tournois monnaie Française du 13^e siècle.', <http://tournois.alain.pagesperso-orange.fr/livre_tournois.htm> [Accessed 29 October 2013]
- Lalanne, Marie Ludovic Chrétien, *Dictionnaire historique de la France, etc* (Paris: Hachette, 1877)
- Lane, John A., 'Arent Corsz Hogenacker (ca. 1579-1636) an account of his typefoundry and a note on his types Part two: the types', *Quaerendo*, 25/3 (1995), 163-187
- , 'Nicolaes Briot and Menasseh ben Israel's first Hebrew types', in *Bibliotheca Rosenthaliana: Treasures of Jewish Booklore*, ed. by Offenberg, A. K. (Amsterdam: Amsterdam University Press, 1994), pp. 27-28
- Lane, John A., Hendrik D. L. Vervliet, and British Library, *Early type specimens in the Plantin-Moretus Museum: annotated descriptions of the specimens to ca. 1850 (mostly from the Low Countries and France) with preliminary notes on the typefoundries and printing offices* (London and New Castle, Delaware: British Library and Oak Knoll Press, 2004)
- Lang, Jack, *François Ier* (Paris: Editions Perrin, 1997)
- Layton, Evro, *The sixteenth century Greek book in Italy: printers and publishers for the Greek world, Library of the Hellenic Institute of Byzantine and post-Byzantine studies* (Venice: Istituto ellenico di studi bizantini e postbizantini di Venezia, 1994)
- Le Bé, Guillaume, 'Epreuves de lettres que j'ay taillées, tant en six et sept sortes de poinçons de lettres hebraïques, que autres lettres, en divers temps et pour diverses personnes et partie aussy pour moy', (Paris: Bibliothèque nationale de France, ?).N.A. fr-4528
- , *Sixteenth-century French typefounders: the Le Bé memorandum*. ed. by Harry Carter (Paris and Oxford: André Jammes, 1967)
- , 'Spécimens de caractères hébreux gravés à Venise et à Paris par Guillaume Le Bé (1546-1574)', (Paris: Bibliothèque Nationale, ?).RES- X- 1665
- Le Bé, Pierre, and Jan Tschichold, *A Book of Letter Forms by Pierre Le Bé, Paris 1601/Ein Buchstabenbuch von Pierre le Bé, Paris 1601/Modeles de lettres de Pierre le Bé* (Stuttgart-Bad Cannstatt: Cantz'sche Druckerei, 1974)
- Le Clert, Louis, *Le Papier. Recherches et notes pour servir à l'histoire du papier, principalement à Troyes et aux environs depuis le quatorzième siècle, etc* (Paris: A L'enseigne du Pégase, 1926)
- Le service éducatif de la MGT (Médiathèque du Grand Troyes), 'Les Pithou, une Famille au Coeur des Guerres de Religion '2012)<http://www.cndp.fr/crdp-reims/fileadmin/documents/preac/patrimoine_mediatheque_troyes/3-Les_Pithou__une_famille_au_coeur_des_guerres_de_religion_site_academique.pdf>[Accessed 08 February 2012]
- Lefanu, William, 'André Wechel', *Huguenot Society Proceedings* (1966), 58-81
- Lefèvre, Pierre Théotiste, *Guide Pratique du Compositeur d'Imprimerie* (Paris: Librairie de Firmin Didot Frères, 1855)
- Lefranc, Abel, 'Nicolas Clénard, humaniste belge, et les commencements du Collège de France', *Comptes-rendus des séances de l'Académie des Inscriptions et Belles-Lettres*, 85e année, N. 5 (1941), 422- 439
- Lelièvre, Jacques, *La pratique des contrats de mariage chez les notaires au Châtelet de Paris de 1769 à 1804* (Paris: Cujas, 1959)
- Lepreux, Georges, *Gallia typographica: ou, Répertoire biographique et chronologique de tous les imprimeurs de France depuis les origines de l'imprimerie jusqu'à la révolution, Série Parisienne (Paris et l'Île de France)* (Paris: H. Champion, 1911)
- Leroy, Aubin, and Régine Malveau, 'Le Fonds Ballard-Vinchon 1568-1887' (2005)<<http://archives.cg37.fr/UploadFile/GED/SerieJ/1178540575.pdf>> [Accessed 12 January 2013]
- Levarie, Norma, *The Art & History of Books* (New York: J.H. Heineman/Da Capo Paperback, 1968)
- Levasseur, Emile, and Académie des sciences morales et politiques, *Ordonnances des rois de France: règne de François Ier* (Paris: Imprimerie nationale, 1902)
- Lloyd Jones, G., *The Discovery of Hebrew in Tudor England: a third Language* (Manchester: Manchester University Press, 1983)
- Loewe, Raphael, *The Rylands Haggadah: a medieval Sephardi masterpiece in facsimile* (London: Thames and Hudson, 1988)

- Long, Christopher, '*Nicolas Vlasto, Printer & Publisher, Venice C15th*' (2000) <<http://www.christopherlong.co.uk/per/vlasto.nicolas.html>> [Accessed 14 April 2013]
- Lottin, Augustin Martin, *Catalogue chronologique des Libraires et des Libraires-Imprimeurs de Paris* (Paris: Jean-Roch Lottin, 1789)
- Lubell, Stephen, 'The Hebrew Typeface Designs of Zvi Narkis', *Gutenberg Jahrbuch* (2003), 317-233
- , 'Hebrew Typography - from the sacred to the mundane', *Typo/Graphic*, 41 (1990), 16-23
- , *The Use of Hebrew in the Antwerp Polyglot Bible* (London: Institute of English Studies, 2008)
- 'Luzzato', <<http://www.jewishencyclopedia.com/articles/10203-luzzatto-luzzatti>> [Accessed 6 November 2013]
- Lyall, R.J., 'Materials: The Paper Revolution', in *Book production and publishing in Britain, 1375-1475*, ed. by Griffiths, Jeremy and Derek Pearsall (Cambridge [England] ; New York: Cambridge University Press, 1989)
- Malkiel, David, 'Renaissance in the Graveyard: The Hebrew Tombstones of Padua and Ashkenazic Acculturation in Sixteenth-Century Italy', *AJS Review* (2013), 333-370
- Malter, Henry, *Saadia Gaon: his life and works* (Philadelphia: Jewish Publications Society of America, 1921)
- Man, John, *The Gutenberg revolution: the story of a genius and an invention that changed the world* (London: Review, 2002)
- Manuel, Frank E., *The broken staff: Judaism through Christian eyes* (Cambridge, Massachusetts and London, England: Harvard University Press, 1992)
- Marcon, Susy, Marino Zorzi, and Biblioteca Nazionale Marciana., *Aldo Manuzio e l'ambiente veneziano, 1494-1515*. 1a (Venezia: Il Cardo, 1994)
- Marcus, Jacob Rader, and Marc Saperstein, *The Jew in the Medieval World: A Source Book, 315-1791* (Cincinnati: Hebrew Union College Press, 1999)
- Mardersteig, Giovanni, 'Aldo Manuzio e i caratteri di Francesco Griffo da Bologna', in *Studi di bibliografia e di storia in onore di Tammaro de Marinis. Verona 1964*. (Verona, 1964)
- Martin, Henri-Jean, *Livre, pouvoirs et société à Paris au XVIIIe siècle, 1598-1701* (Genève: Librairie Droz, 1969)
- , 'Politique et typographie à la Renaissance: Histoire d'une divorce', in *Les trois révolutions du livre: actes du colloque international de Lyon/Villeurbanne (1998)*, ed. by Barbier, Frédéric and Société des bibliophiles de Guyenne (Genève: Droz, 2001), pp. 71-91
- Martin, James D., *Davidson's Introductory Hebrew Grammar*. 27th edition (London and New York: Continuum/T & T Clark Ltd, 2006)
- Martini, Jutta, 'Hanauer Drucker und Verleger von 1593 bis 1776', *Gutenberg-Jahrbuch*, 73 (1998), 191-207
- Marx, Moses, 'Gershom (Hieronymus) Soncino's Wander-Years in Italy, 1498-1527 Exemplar Judaicae Vitae', *Hebrew Union College Annual*, XI (1936), 427-501
- , *History and annals of Hebrew printing in the fifteenth and sixteenth centuries* (Cincinnati: Hebrew Union College, 1982)
- McLeod, Randall, 'ALTVM SAPERE: Parole d'homme et Verbe divin. Les chronologies de la Bible hébraïque in-4° de Robert Estienne', in *La Bible imprimée dans l'Europe moderne (XVe-XVIIIe siècle)*, ed. by Schwarzbach, Bertram (Paris: Bibliothèque nationale de France, 1999), pp. 83-141
- McLuhan, Marshall, *The Gutenberg Galaxy : The Making of Typographic Man* (London Routledge & Kegan Paul, 1962)
- Mediavilla, Claude, *Histoire de la calligraphie française* (Paris: Albin Michel, 2006)
- Menato, Marco, Ennio Sandal, and Giuseppina Zappella, *Dizionario dei tipografi e degli editori italiani. Il Cinquecento* (Milano: Editrice Bibliografica, 1997)
- Mesguich, Sophie Kessler, 'Early Christian Hebraists', in *Hebrew Bible/Old Testament*, ed. by Sæbø, Magnes (Göttingen: Vandenhoeck & Ruprecht, 2008)
- Meyer, Herrmann, 'Bibliographical notes on the historical development of Hebrew typography', in *Thesaurus typographiae Hebraicae saeculi XV = Hebrew printing during the fifteenth century (Ha-Otsar li-melekheth ha-defus ha-ivri ha-rishonah ad shenat r"ss)* ed. by Freimann, Aron and Moses Marx (Jerusalem: The Universitas Booksellers, 1969)
- Meynell, Francis, and Stanley Morison, 'Printer's Flowers and Arabesques', in *Fleuron anthology. Chosen and with a retrospectus by Francis Meynell and Herbert Simon*, ed. by Meynell, Francis and Herbert Simon (Tonbridge, Kent and London, Toronto and Buffalo: Ernest Benn and University of Toronto Press, 1973), pp. 1-30

- Michaud, Louis Gabriel, *Biographie universelle ancienne et moderne L.G. Michau, Libraire-Editeur* (Paris: 45 tom. , 1823)
- Ministère de la Culture et de la Communication, '*Garamont ou Garamond?*' <http://garamond.culture.fr/fr/page/garamont_ou_garamond> [Accessed 6 November 2013]
- '*Money and Prices*', <<http://www.maisonstclair.org/resources/pricelist/pricelist.html>> [Accessed 6 November 2013]
- Mores, Edward Rowe, Harry Graham Carter, Christopher Ricks, Samuel A. catalogue and specimen of the large and extensive printing-type foundry of the late ingenious Mr John James which will be sold by auction th June Paterson, and John d James, *A dissertation upon English typographical founders and founderies (1778): with A catalogue and specimen of the typefoundry of John James (1782), Oxford Bibliographical Society publications. New series ; v.9* (Oxford: Oxford University Press, 1961)
- Morin, Louis, 'Un Atelier de Peintres-Dominotiers à Troyes', *Bulletin du Bibliophile et du Bibliothécaire* (1899), 105-118
- Morison, Stanley, and Harry Carter, *John Fell, the University Press and the 'Fell' types* (Oxford: Clarendon, 1967)
- Morison, Stanley, and Ernest Crutchley, *A tally of types* (Cambridge: Cambridge University Press, 1973)
- Morris, Jan, *Venice* (London: Faber and Faber, 1993)
- Mosher, Fredric J., 'A New Estienne Catalogue', *Library*, s6-l (4) (1979), 361-366
- Mosley, James, *A Dictionary of Punchcutters for Printing Types (Unpublished)* (London, 1999)
- , *Documents relating to the foundry of Guillaume Le Bé: a summary and some notes*, 2011)
- , 'Fallen and threaded types' (2007)<http://typefoundry.blogspot.co.uk/2007_06_01_archive.html> [Accessed 10 April 2017]
- , '*Garamond or Garamont?*' (2011)<<http://typefoundry.blogspot.co.uk/2011/04/garamond-or-garamont.html>> [Accessed 6 November 2013]
- , 'Garamond, Griffio and Others: The Price of Celebrity', *BIBLIOLOGIA An International Journal of Bibliography, Library Science, History of Typography and the Book*, 1 (2006), 17-41
- Moxon, Joseph, Harry Carter, and Herbert Davis, *Mechanick Exercises on the Whole Art of Printing* (London: Oxford University Press, 1962)
- Museum, Plantin-Moretus, *Inventaris van de stempels en matrijzen van het Museum Plantin-Moretus. Inventory of the Plantin-Moretus Museum punches and matrices. Engff. viii. 170.* Antwerpen, 1960)
- Narkiss, Bezalel, and Leone Modena, *Seder Hagadah shel Pesach, Venetsyah 369 = The Passover Haggadah, Venice 1609* (Jerusalem: Makor, 1974)
- Naveh, Joseph, *Early History of the Alphabet: An introduction to West Semitic Epigraphy and Palaeography* (Jerusalem: The Magnes Press, 1982)
- Nelson, Stan, '1-Punchcutting at the Atelier Press & Letterfoundry '2009)' <<http://www.youtube.com/watch?v=eExllUeGtvc>> [9 April 2014],
- , '2- Tempering Punches and Striking Matrices '2009)' <<http://www.youtube.com/watch?v=QyiCPzERIGA>> [9 April 2014],
- Netanel, Neil Weinstock, 'Maharan of Padua v. Giustiniani: the Sixteenth Century Origins of the Jewish Law of Copyright', *The Houston Law Review*, 44 (2007), 821-870
- Neufville, Jean de, *Ioannis Neovillei Genvillani in septem Davidis Psalmos quos poetentiales vocant, commentarii* (Paris: André Wechel and Galiot du Pré, 1556)
- Nielsen, Bruce, 'Daniel van Bomberghen, a Bookman of Two Worlds', in *The Hebrew book in early modern Italy*, ed. by Hacker, Joseph and Adam Shear (Philadelphia, Pa.: University of Pennsylvania Press, 2011), pp. 56-75
- '*Notes on Imitation and Forgery*', <<http://www.umich.edu/~engtt516/forgerysource.html>> [Accessed 4 September 2013]
- Nuovo, Angela, *The Book Trade in the Italian Renaissance* (Leiden and Boston: Brill, 2013)
- '*Obadiah (Yareh) Ben Abraham Bertinoro*', <<http://www.jewishencyclopedia.com/articles/3171-bertinoro-obadiah-yareh-b-abraham>> [Accessed 20 June 2011]
- Offenberg, A. K., *Hebrew Incunabula in public collections* (Nieuwkoop: De Graaf, 1990)
- , 'A Hidden Treasure in the Athias Cabinet or Quid Novum in Armariolo Athii', *Zutot*, 2 (2002), 164-169

- , 'The Hidden Treasures of Athias', *Quaerendo*, 37 (2007), 96-100
- , 'The printing history of the Constantinople Hebrew Incunable of 1493: A Mediterranean voyage of Discovery', *British Library Journal*, 22 (1996), 221-235
- Offenberg, A. K., and British Library, *Catalogue of books printed in the XVth century now in the British Library: BMC part XIII, Hebraica* ('t Goy-Houten: Hes & de Graaf, 2004)
- Offenberg, A. K., and C. Moed-van Walraven, *Hebrew incunabula in public collections: a first international census, Bibliotheca humanistica & reformatrica ; v.47*. (Nieuwkoop: de Graaf, 1990)
- Omont, Henri, *Specimens de caractères hébreux gravés à Venise et à Paris par Guillaume Le Bé, 1546-1574* (Paris: Nogent-le-Rotrou, 1887)
- , *Specimens de caractères hébreux, grecs, latins, et de musique gravés à Venise et à Paris par Guillaume le Bé, 1545-1592* (Paris: Nogent-le-Rotrou, 1889)
- 'Online Responsa Project', <<http://www.responsa.co.il/default.aspx>> [Accessed 6 November 2013]
- 'Ordonnance d'août 1539 ou ordonnance de Villers-Cotterêts', <<http://www.assemblee-nationale.fr/histoire/villers-cotterets.asp>> [Accessed 22 March 2012]
- Overy, Joanne Filippone, 'The cost of doing scribal business: Prices of manuscript books in England, 1300-1483', *Book History*, 11 (2008), 1-32
- Oxford University Press, John Fell, and Stanley Morison, *Notes towards a Specimen of the Ancient Typographical Materials principally collected and bequeathed to the University of Oxford by Dr. John Fell, etc.* (Oxford: Oxford University Press, 1953)
- Palatino, Giovanni Battista, *Libro di M. Giovambattista Palatino cittadino romano : nelqual s'insegna à scriuer ogni sorte lettera, antica & moderna, di qualun que natione, con le sue regole, & misure, & esempi : et con vn breve et vtil discorso de le cifre* (Roma, 1550)
- Pallier, Denis, 'Les victimes de la Saint-Barthelemy dans le monde du livre parisiens, documents', in *Le livre et l'historien: Etudes offertes en l'honneur du Professeur Henri-Jean Martin*, ed. by Martin, Henri Jean and Frederic Barbier (Geneve: Librairie Droz, 1997), pp. 141-163
- Paput, Christian, *La lettre/La Gravure du Poinçon typographique* (Tallard: TVSO Editions, 1998)
- Parent, A., *Les métiers du livre à Paris au XVIe siècle (1535-1560)* (Geneva: Librairie Droz, 1974)
- Parent, Annie, and Jeanne Veyrin-Forrer, 'Claude Garamont: New Documents', *The Library*, s5-XXIX (1974), 80-92
- 'Parenzo', <http://www.jewishvirtuallibrary.org/jsource/judaica/ejud_0002_0015_0_15420.html> [Accessed 03 July 2011]
- Parker, M., K. Melis, and H.D.L. Vervliet, 'Typographica Plantiniana II. Early inventories of punches, matrices, and moulds, in the Plantin-Moretus Archives', *De Gulden Passer*, 38 (1960), 1-139
- Parker, Mike, 'Early Typefounder's Moulds in the Plantin-Moretus Museum', *The Library*, s5-XXIX (1) (1974), 93-102
- Parsons, John J., 'Rabbinical Halakhah - Regarding writing the Hebrew Names of God' <http://www.hebrew4christians.com/Names_of_G-d/About_Writing/about_writing.html> [Accessed 7 April 2014]
- Pastor, Ludwig, and Frederick Ignatius Antrobus, *The history of the Popes: from the close of the middle ages, drawn from the secret archives of the Vatican and other original sources*. 4th ed. ([S.l.]: Kegan Paul, Trench, Trubner, 1923)
- Payen, Gullemette, and Michel De Jaeghere, 'Vive Henri IV!', *Le Figaro (Hors Série)* 2010
- Perani, Mauro, 'The death and rebirth of the Hebrew Manuscripts: their reuse as book bindings and recent rediscovery', in *The Italian Genizah. General Survey and Case Studies* (Leiden - Boston: Brill, 2008), pp. 1-19
- Perani, Mauro, and Enrica Sagradini, *Talmudic and midrashic fragments from the Italian Genizah: reunification of the manuscripts and catalogue* (Firenze: La Giuntina, 2004)
- Perles, Joseph, *Beiträge zur Geschichte der hebräischen und aramäischen Studien* (München: Theodor Ackermann, 1884)
- Pérouse, Gabriel-André, André Thierry, André Tournon, and Association d'etude sur l'humanisme la Reforme et la Renaissance. Colloque international, *L'homme de guerre au XVIe siècle: Actes du colloque de l'Association RHR Cannes 1989* (Saint-Etienne: Publications de l'université de Saint-Etienne, 1992)
- Peter, Rodolphe, 'Un Imprimeur de Calvin: Michel du Bois', *Bulletin de la Société d'histoire et d'archéologie de Genève*, 16 (1978), 285-335
- Pilarczyk, Krzysztof, *Leksykon drukarzy ksiąg hebrajskich w Polsce: z bibliografią polono-judaików w językach żydowskich (XVI-XVIII wiek)* (Kraków: Wydawn. Antykwa, 2004)

- 'Plan de Bâle Truschet et Hoyau 1552', <<http://www.bloy geometre-expert.fr/VUESHISTO/TEXTESPLANS/1552.htm>> [Accessed 6 Novembre 2013]
- Plantin-Moretus, Museum, *Letters Proeven/Prenten Smaken (La Saveur des caractères/Le Goût des estampes)* (Antwerp: Museum Plantin-Moretus, 2004)
- Plantin-Moretus Museum, *Letters proeven/Letters smaken/La saveur des caractères/Le goût des estampes* (Antwerpen: Museum Plantin-Moretus 2004)
- Plantin-Moretus., Museum, *Inventaris van de stempels en matrijzen van het Museum Plantin-Moretus. Inventory of the Plantin-Moretus Museum punches and matrices. Eng.* (Antwerpen: Museum Plantin-Moretus 1960)
- Plantin, Christoffel, Jean Denuce, and Max Rooses, *Correspondance de Christophe Plantin. Publiée par M Rooses, Jan Denucé, [Maatschappij der Antwerpsche Bibliophilen. Uitgaven. no. 12, 15, 26, 29-34, etc.]*Antwerpen; Gent, 1883)
- Plantin, Christophe, and Max Rooses, *Correspondance de Christophe Plantin, Uitgaven der Antwerpsche Bibliophilen ; nr. 12, 15, 26, 29-34.* (Nendeln, Liechtenstein: Kraus, 1968)
- Pogue, Samuel F. , and Jonathan Le Cocq, 'Robert Ballard'2011)<<http://0-www.oxfordmusiconline.com.catalogue.ulrls.lon.ac.uk/subscriber/article/grove/music/01889pg1> >[Accessed 8 April 2013]
- Pollak, Michael, 'Some observations on printing in a Hebrew text dated 1612', *Gutenberg-Jahrbuch* (1976), 315-325
- Pollard, Graham, 'The pecia system in the medieval universities', in *Medieval scribes, manuscripts & libraries : essays presented to N.R. Ker*, ed. by Ker, N. R., M. B. Parkes and Andrew G. Watson (London: Scolar Press, 1978)
- 'Portmanteau Words', <<http://users.tinyonline.co.uk/gswithenbank/portmant.htm>> [Accessed 17 October 2013]
- Post, Rudolf, and Jutta Schumacher, 'Die Jüdische Drucker Israel Sifroni in Freiburg i. Br.', *Zeitschrift des Geschichtsvereins Schau-ins-Land*, 125 (2006), 63-75
- Postel, Claude, *Les Ecrits de Guillaume Postel publiés en France et leurs éditeurs 1538-1579, Travaux d'humanisme et Renaissance ; no.265.* (Genève: Droz, 1992)
- Postel, Guillaume, and François Secret, *Interprétation du Candélabre de Moïse en hébreu, latin, italien et français, avec une introduction* (Nieuwkoop: De Graaf, 1966)
- Prijs, Joseph, *Die Basler hebräischen Drucke, 1516-1828* (Basel: Sepher-Verlag, 1952)
- Proto-Sinaitic Inscriptions'2010)<<http://net.lib.byu.edu/imaging/negev/Origins.html>>[Accessed 20 April 2010]
- 'Proto-Sinaitic Inscriptions', <<http://net.lib.byu.edu/imaging/negev/Origins.html>> [Accessed 6 November 2013]
- Racaut, Luc, 'Nicolas Chesneau, Catholic Printer in Paris during the French Wars of Religion', *The Historical Journal*, 52 (2009), 23-41
- Rapp, Richard Tilden, *Industry and economic decline in seventeenth-century Venice, Harvard historical monographs ; no. 69.* (Cambridge, Mass: Harvard University Press, 1976)
- Ravid, Benjamin, 'The Prohibition against Jewish Printing and Publishing in Venice and the Difficulties of Leone Modena', in *Studies in medieval Jewish history and literature (Harvard Judaic monographs; 2)*, ed. by Twersky, Isadore (Cambridge, Mass. ; London: Harvard University Press, 1979), pp. 135-153
- Reed, Talbot Baines, and A. F. Johnson, *History of the old English Letter Foundries* (London: Faber, 1952)
- René, Adophe, *Epreuves de Caractères* (Paris: Fonderie Générale des Caractères Français et Etrangers, 1858)
- Renouard, Ant Aug, *Annales de l'Imprimerie des Alde* (Paris: Jules Renouard, Libraire, 1834)
- Renouard, Antoine Augustin, *Annales de l'Imprimerie des Estienne, ou, Histoire de la Famille des Estienne et de ses éditions* (Paris: Jules Renouard & Cie, 1837)
- Renouard, Philippe, *Documents sur les imprimeurs, libraires, cartiers, graveurs, fondeurs de lettres, relieurs, doreurs de livres, faiseurs de fermoirs, enlumineurs, parcheminiers et papetiers ayant exercé à Paris de 1450 à 1600, Société de l'histoire de Paris et de l'ile-de-France* (Paris: H. Champion, 1901)
- , *Imprimeurs & libraires parisiens du XVIe siècle: ouvrage publié d'après les manuscrits de Philippe Renouard* (Paris: Bibliothèque nationale, 1969)

- , *Imprimeurs parisiens, libraires, fondateurs de caractères et correcteurs d'imprimerie: depuis l'introduction de l'imprimerie à Paris (1470) jusqu'à la fin du XVIe siècle* (Paris: A. Claudin, 1898)
- , *Répertoire des imprimeurs parisiens, libraires, fondateurs de caractères en exercice à Paris au XVIIIème siècle* ([France]: Jacques Laget, 1995)
- , *Répertoire des imprimeurs parisiens, libraires, fondateurs de caractères et correcteurs d'imprimerie: depuis l'introduction de l'imprimerie à Paris (1470) jusqu'à la fin du seizième siècle* (Paris: Libraire A. Claudin, 1898)
- Renouard, Philippe, Paris (France). Service des travaux historiques de la ville de Paris., and Bibliothèque nationale (France), *Imprimeurs & libraires parisiens du XVIe siècle, Histoire générale de Paris*. (Paris: Service des travaux historiques de la ville de Paris, 1964)
- Renouard, Philippe, Jeanne Veyrin-Forrer, and Brigitte Moreau, *Répertoire des imprimeurs parisiens, libraires, fondateurs de caractères et correcteurs d'imprimerie depuis l'introduction de l'Imprimerie à Paris (1470) jusqu'à la fin du seizième siècle* (Paris: Lettres modernes, 1965)
- Reske, Christoph, *Die Buchdrucker des 16. und 17. Jahrhunderts im deutschen Sprachgebiet: auf der Grundlage des gleichnamigen Werkes von Josef Benzing, Beiträge zum Buch- und Bibliothekswesen, Bd. 51*. (Wiesbaden: Harrassowitz, 2007)
- Richardson, Brian, *Printing, writers, and readers in Renaissance Italy* (Cambridge: Cambridge University Press, 1999)
- Richaudeau, François, and John Dreyfus, *La Chose Imprimée* (Paris: Retz: CEPL, 1977)
- Richler, Benyamin, *Hebrew Manuscripts in the Vatican Library: Catalogue* (Rome: Bibliotheca Apostolica Vaticana, 2008)
- Richter, Helmut, 'Hebrew Cantillation Marks And Their Encoding' 1999) <<http://www.mechonmamre.org/c/hr/>> [Accessed 6 February 2013]
- , 'Hebrew Cantillation Marks And Their Encoding' <<http://www.mechonmamre.org/c/hr/>> [Accessed 24 June 2011]
- Roberts, Penny, *A city in conflict: Troyes during the French wars of religion* (Manchester; New York: Manchester University Press and St. Martin's Press, 1996)
- Rondot, Natalis, and Henri de La Tour, *Les Médailleurs et les Graveurs de monnaies, jetons et médailles en France* (Paris: Ernest Leroux, Editeur, 1904)
- Roper, Geoffrey 'Arabic Printing and Publishing in England before 1820', *Bulletin (British Society for Middle Eastern Studies)*, 12 (1985), 12-32
- Rouse, Richard H., and Mary A. Rouse, *Manuscripts and their makers: commercial book producers in medieval Paris, 1200-1500* (Turnhout: Harvey Miller, 2000)
- Ruderman, David B., *Early Modern Jewry* (Princeton and Oxford: Princeton University Press, 2010)
- Ryder, John, *Printing for Pleasure* (London: The Bodley Head, 1976)
- Sachs, Hans, and Jost Amman, *Eygentliche Beschreibung aller Stände auff Erden, hoher vnd nidriger, geistlicher vnd weltlicher, aller Künsten, Handwercken vnd Händeln &c. vom grösten biss zum kleinsten, auch von jrem Vrsprung, Erfindung vnd gebreuchen von dem weitberümpften Hans Sachsen ganz fleissig beschrieben vnd in Teutsche Reimen gefasset, sehr nutzbarlich vnd lustig zu lesen, vnd auch mit kunstreichen figuren, deren gleichen zuvor niemands gesehen ... allen Künstlern ... zu sonderlichem Dienst in Druck verfertigt* (Gedruckt zu Franckfurt am Mayn: bey Georg Raben, in Verlegung Sigmund Feyerabents, 1568)
- Sangster, Alan, 'The printing of Pacioli's Summa in 1494: how many copies were printed?', *Accounting Historians Journal*, 34 (2007), 125-145
- Savage, William, *A Dictionary of the Art of Printing* (London: Longman, Brown, Green and Longmans, 1841)
- Schonfield, Jeremy, *Undercurrents of Jewish prayer* (Oxford: Littman Library of Jewish Civilization, 2006)
- Schper, Abraham, 'Christian Hebraists in Sixteenth Century England', University of London, 1944)
- Schreiber, Fred, *The Estiennes: an annotated catalogue of 300 highlights of their various presses* (New York (3140 Netherland Ave., Bronx, New York 10463): E.K. Schreiber, 1982)
- Schrijver, Emile G. L., 'Be-Otiyyot Amsterdam: Eighteenth-Century Hebrew Manuscript Production in Central Europe: The Case of Jacob Ben Judah Leib Shamas ', *Quaerendo*, 20 (1990), 24-62
- , 'The first Hebrew book printed in Amsterdam, by a Jew, 1627', in *As it is written: lectures on the art of Hebrew manuscripts and books* (Metropolitan Museum of Art, New York, 2010)
- , 'Hebrew Manuscripts after Gutenberg', in *As it is written: Lectures on the Art of Hebrew Manuscripts and Books* (Metropolitan Museum of Art, New York, 2010)

- Schrijver, Emile G. L., Falk Wiesemann, Evelyn M. Cohen, Sharon Liberman Mintz, Menahem Schmelzer, Ardon Bar-Hama, René Braginsky, Schweizerisches Landesmuseum (Zürich), Schweizerisches Nationalmuseum., Universiteit van Amsterdam. Bibliotheek. Bijzondere Collecties., and Bibliotheca Rosenthaliana., *Schöne Seiten: jüdische Schriftkultur aus der Braginsky Collection* (Zürich: Scheidegger & Spiess, 2011)
- Schrijver, Emile G.L., 'Be-Otiyyot Amsterdam - Eighteenth century Hebrew manuscript production in Central Europe: the case of Jacob ben Judah leib Shamas', *Quaerendo*, 20 (1990), 24-62
- Schwarzbach, Bertram, 'Geddes in France', in *The Bible and the Enlightenment: a case study - Dr Alexander Geddes (1737-1802) : (the proceedings of the Bicentenary Geddes Conference held at the University of Aberdeen, 1-4 April 2002)*, ed. by Johnstone, William (London: T & T Clark International, 2004), pp. 78-118
- Schwarzfuchs, Lyse, *L'hébreu dans le livre à Genève au XVIe siècle* (Genève Librairie Droz, 2011)
- , *L'hébreu dans le livre lyonnais au XVIe siècle* (Lyon: ENS Editions/Institut d'Histoire du Livre, 2008)
- Schwarzfuchs, Lyse, and Antoine Coron, *Le livre hébreu à Paris au XVIe siècle: inventaire chronologique* (Paris: Editions de la Bibliothèque nationale de France, 2004)
- Sclar, David, *Treasures of the Valmadonna Trust Library* (London and New York: Valmadonna trust Library, 2011)
- 'Sha'arei Dura', <http://www.virtualjudaica.com/Item/21804/Sha%27arei_Dura> [Accessed 05 October 2013]
- Shaw, David, 'Standardization of Type Sizes in France in the early Sixteenth Century', *The Library*, s6-111(4) (1981), 330-336
- 'Shem-Tov ben Avraham ibn Gaon', <<http://www.jewishencyclopedia.com/articles/13543-shem-tob-ben-abraham-ibn-gaon>> [Accessed 07 July 2011]
- Silberberg, G., *Principles of Printing (Torat HaDefus)* (Tel Aviv: The Union of Printing Workers in Israel, 1968)
- Sirat, Colette, and N. R. M. De Lange, *Hebrew manuscripts of the Middle Ages* (Cambridge: Cambridge University Press, 2002)
- Smeijers, Fred, *Counterpunch: Making type in the sixteenth century, designing type now* (London: Hyphen Press, 1996)
- Socard, Emile, *Biographie des personnages de Troyes et du département de l'Aube* (Troyes: Librairie Léopold Lacroix, 1882)
- 'Special letters', <http://www.win.tue.nl/~aeb/natlang/hebrew/hebrew_bible.html> [Accessed 6 November 2013]
- Speckter, Martin K., *Disquisition of the Composing Stick* (New York: The Typophiles Inc., 1971)
- Stankiewicz, Florine 'Répertoire de l'imprimeur Michel Le Noir - L'EAD au service du livre ancien', Université de Lyon, 2009)
- Stanton, Ralph, 'Aldus Pius Manutius - Publisher of Renaissance Venice' (2008)<<http://www.lib.sfu.ca/special-collections/projects/aldus>> [Accessed 13 September 2012]
- Steinberg, S. H., *Five hundred years of printing* (Harmondsworth, Middx.: Penguin Books, 1955)
- Stern, Adi, 'Aleph=X, or contemporary Hebrew bad type', in *Bad Type: Third annual Friends of St Bride conference* (St Bride, London, 2004)
- Stevens, Linton C., 'The motivation for Hellenic studies in the French Renaissance', *Studies in Philology*, 47 (1950), 113-125
- Tamani, Giuliano, 'I Libri ebraici del Cardinal Domenico Grimani', *Annali di Ca' Foscari*, XXXIV (1995), 5-52
- 'Tanakh', <http://www.bibliahebraica.com/the_texts/tanakh.htm> [Accessed 01 November 2013]
- Terry, Michael, *Reader's guide to Judaism* (Chicago ; London: Fitzroy Dearborn, 2000)
- Thomas, Martyn, John A. Lane, and Anne Rogers, *Harry Carter, typographer* (Bath: Old School Press, 2005)
- Tilley, Arthur 'Humanism under Francis I', *The English Historical Review*, 15 (1900), 456-478
- Timperley, Charles Henry, *A Dictionary of Printers and Printing, with the Progress of Literature, ancient and modern: bibliographical illustrations, etc.* London, 1839)
- Tinto, Alberto, 'Per una storia della tipografia orientale a Roman nell'Età dell'Controriforma', *Accademie e Biblioteche d'Italia*, XLI (1973), 280-295
- Tisserant, Eugene, *Specimina codicum orientalium, Tabulae in usum scholarum* (Bonnae: A. Marcus et E. Weber, 1914)

- Tov, Emanuel, *Hebrew Bible, Greek Bible and Qumran: collected essays* (Tübingen: Mohr Siebeck, 2008)
- Toy, Crawford Howell, and Wilhelm Bacher, 'Punctuation', in *The Jewish Encyclopedia*, ed. by Adler, Cyrus (New York and London: Funk & Wagnalls, 1907)
- Trzcinski, Andrzej, 'Badania paleograficzne nad pismem hebrajskim sredniowiecznym i nowozytnym (Palaeographic Studies on Medieval and Modern Hebrew Writing)', *Annales Universitatis Mariae Curie-Sklodowska*, II (2004), 61-81
- Turner, Francis, 'Money and exchange rates in 1632' 2010 <1632.org/1632Slush/1632money.rtf> [Accessed 17 July 2011]
- Universiteitsbibliotheek Amsterdam, and John A. Lane, *Een punt voor typografie: De Typografische Bibliotheek in de Universiteitsbibliotheek Amsterdam* (Amsterdam: de Universiteitsbibliotheek Amsterdam, 2001)
- University of California - Los Angeles Library, *The Aldine Press: catalogue of the Ahmanson-Murphy collection of books by or relating to the press in the Library of the University of California, Los Angeles: incorporating works recorded elsewhere* (Berkeley: University of California Press, 2001)
- Urdike, Daniel Berkeley, *Printing types: their history, forms, and use: a study in survivals*. 3rd ed. (Cambridge, Mass.: Belknap; London: Oxford University Press, 1962)
- van der Heide, Albert, *Hebraica veritas: Christoffel Plantin en de christelijke Hebraïsten: catalogus bij de tentoonstelling 'Hebraica veritas, sprak God Hebreeuws?, Lashon ha-Kodesh mi-pi ha-gevurah, 16 mei-17 augustus 2008* (Antwerpen: Plantin-Moretus Museum/Prentenkabinet, 2008)
- van Iseghem, A. F., *Biographie de T. Martens d'Alost ... suivie de la bibliographie de ses éditions* (Malines: P.J. Hanicq, 1852)
- van Ortoy, Fernand, 'Contribution à l'histoire des imprimeurs et des libraires belges établis à l'étranger', *Revue des Bibliothèques* (1927), 101-107
- , 'Les van Bomberghen d'Anvers: Imprimeurs, Libraires et Editeurs', *De Gulden Passer* (1924), 131-144
- Varga, Beáta 'Écrire: transcrire ou bien orthographier? Problèmes d'analyse phonétique des textes écrits du Moyen Âge et de la Renaissance', *Revue d'Études Françaises*, No 7 (2002), 89-98
- Vervliet, H. D. L., 'Concentration vs. Specialization in the Technical Printing Professions from the Fifteenth to the Nineteenth centuries', in *Produzione e commercio della carta e del libro secc. XIII-XVIII: atti della "Ventitreesima Settimana di studi" 15-20-aprile 1991 Atti delle "settimane di studi" e altri convegni. Serie II; 23.*, ed. by Istituto internazionale di storia economica F. Datini. Settimana di studi (23rd: 1991: Prato Italy) and Simonetta Cavaciocchi (Firenze: Le Monnier, 1992), pp. 511-519
- , 'Cyrillic & oriental typography at the end of the sixteenth century', in *The Palaeotypography of the French Renaissance: Selected Papers on Sixteenth-Century Typefaces* (Leiden: Brill, 2008), pp. 427-474
- , *French Renaissance Printing Types: A Conspectus* (London: The Bibliographical Society, 2010)
- , *The Palaeotypography of the French Renaissance: Selected Papers on Sixteenth-Century Typefaces* (Leiden: Brill, 2008)
- , 'Printing Types of Pierre Haultin: c. 1510-1587', in *The Palaeotypography of the French Renaissance: Selected Papers on Sixteenth-Century Typefaces* (Leiden: Brill, 2008), pp. 242-285
- , 'Robert Estienne's Printing Types', in *The Palaeotypography of the French Renaissance: Selected Papers on Sixteenth-Century Typefaces* (Leiden and Boston: Brill, 2004), pp. 105-148
- Vervliet, Hendrik, and Harry Carter, *Sixteenth-century printing types of the Low Countries* (Amsterdam: Menno Hertzberger & Co.: , 1968)
- Vinograd, Yeshayahu, *Otsar ha-sefer ha-lvri: reshimat ha-sefarim she-nidpesu be-otiot Ivrit me-reshit ha-defus ha-lvri bi-shenat 229 (1469) ad shenat 623 (1863)* (Yerushalayim: Ha-Makhon le-bibliyografyah memushshevet, 1995)
- Voet, Leon, *The Golden Compasses. A history and evaluation of the printing and publishing activities of the Officina Plantiniana at Antwerp, etc. vol. 2. The management of a printing and publishing house in Renaissance and Baroque* (Amsterdam: Vangendt & Co, 1972)

- Voet, Leon, and Jenny Voet-Grisolle, *The Plantin Press, 1555-1589: a bibliography of the works printed and published by Christopher Plantin at Antwerp and Leiden* (Amsterdam: Van Hoeve, 1980)
- '*The Wars of Religion*', <<http://www.lepg.org/wars.htm>> [Accessed 16 July 2011]
- Weigert, Roger-Armand *Inventaire du fond français, graveurs du XVIIe Siecle* (Paris: Bibliothèque nationale, 1939-1973)
- Wekerlin, J-B, 'Histoire de l'impression de la musique en France', *Le Menestrel*, 34 (1868), 263-267
- Werdet, Edmond, *Histoire du Livre en France depuis les temps les plus reculés jusqu'en 1789. Tom. 1-4* (Paris: E. Dentu, 1861)
- White, Alex W., '*Nicolas Jenson's Typographic Contributions*' (2010)<<https://tdc.org/articles/nicolas-jensons-typographic-contributions/>> [Accessed 27 September 2012]
- White, James, *The churches & chapels of old London: with a short account of those who have ministered in them* (London: Printed for private circulation, 1901)
- Wildenstein, Georges, 'Le Goût pour la Peinture dans la bourgeoisie Parisienne entre 1550 et 1610', *Gazette des Beaux-Arts* (1962), 11-268
- Williamson, Hugh, *Methods of Book Design: The practice of an industrial craft* (London: Oxford University Press, 1956)
- Wolf, Karl Lothar, *Terminologische Untersuchungen zur Einführung des Buchdrucks im französischen Sprachgebiet* (Tübingen: Niemeyer, 1979)
- Wolfe, Richard J., *Marbled paper: its history, techniques, and patterns: with special reference to the relationship of marbling to bookbinding in Europe and the Western world* (Philadelphia: University of Pennsylvania Press, 1990)
- Wood, James B., 'The Impact of the Wars of Religion: A View of France in 1581', *The Sixteenth Century Journal*, Vol. 15, (1984), 131-168
- Yeshuot Meshiho of Amsterdam, '*Letter by 24 members of the pious society Yeshuot Meshiho of Amsterdam to hail Shabtai Tzvi as Messiah. In the handwriting of Eliah ben Michael Judah Leon. Amsterdam*' (1666)<<http://www.etsheimmanuscripts.nl/portfolio/eh-47-a-11/>> [Accessed 6 April 2014]
- Zafren, Herbert C., 'Dyhrenfurth and Shabtai Bass: A typographic Profile', in *Studies in Jewish bibliography, history and literature in honor of I. Edward Kiev*, ed. by Kiev, I. Edward and C. Berlin ([S.I.]: Ktav, 1971), pp. 543-581
- Zappella, Giuseppina, *Il libro antico a stampa (Parte Prima)* (Milano: Editrice Bibliografica, 2001)

Impressum

This thesis was written and formatted using MS Office Word 10 for the text and EndNote X5 to create the bibliographies and in text citations. The PDF versions were created on Acrobat PDFmaker. Graphic images and assembled alphabets were produced on CorelDraw Graphics Suite X6, with additional use of PhotoScape V3.6.3. Icono Screen Calipers V.4 was used to measure and calculate image dimensions. Images where necessary were scanned on a HP Inkjet printer PSC 1410. The whole was done on a PC desktop computer running Windows 7.

The style used for this thesis is based on the MHRA (Modern Humanities Research Association) Style Guide and the *Oxford Manual of Style*. The style follows the University of London PhD Regulations Regulations for the Degrees of MPhil and PhD (September 2009) with agreed exceptions as to formatting and word count.

The files were printed and bound by The Printing Centre, 37 Store Street, London WC1E 7BS.